

Environmental Control and Waste Disposal

Berl A. Koch, R. H. Hines, Gary L. Allee

A system for aerobic oxidation of waste has been used continuously since 1968 and is now functioning successfully. Figure 11.1 shows general design of the units.

Originally "paddle wheels" were used to circulate liquid waste, keep solids in suspension, and mix oxygen into the liquid. Their performance, however, was less than desirable. Excessive foaming of liquid in the pits kept recurring, and maintenance of "paddle wheels" was expensive and time consuming.

In late 1971 and early 1972 all "paddle wheels" were replaced by Aerob-A-Jets which require little maintenance time. Oxidation of solids in the pits has continued at a satisfactory rate; odors have remained at an acceptable level, and foaming has been reduced to a minimum. All data reported here (table 11.1) were collected in 1974 since the conversion to Aerob-A-Jets.

In November, 1973, a negative ion dispersion system was installed in the nursery barn and farrowing barn to suppress atmospheric dust (Clean Air Systems, Inc.). Though equipment needed to measure reduction in atmospheric dust or odor levels has not been available, persons working in both barns report they are coughing less and have less eye and nasal irritation than before. It has been impossible to measure differences in pig responses, but no ill effects have been observed.

In April, 1974, we began to add small quantities of a commercial bacterial preparation to each of the pits (Puritan Live Micro-Organisms) in an attempt to further reduce odors. Measurements are not yet available, but observations by those involved are favorable. One obnoxious odor (probably H_2S) has disappeared.

Table 11.1 Data From Aerobic Oxidation Pits Installed in Swine-production Facilities at Kansas State University in 1968.

Pit ¹ :	January, 1974					March, 1974					June, 1974				
	1	2	3	4	5	1	2	3	4	5	1	2	3	4	5
Energy per day, KWH	70.0	41.9	----	70.6	----	65.6	----	----	60.0	----	---	36.9	----	----	----
Fluid temp., °F.	66	72	70	63	68	70	70	70	66 ²	75	77	78	77	73	73
Fluid pH, paper	6.5	8.0	8.0	8.0	8.0	6.5	7.0	7.0	7.0	7.5	5.0	7.8	7.8	8.2	8.2
Fluid D.M. ^a ,%	0.62	2.21	1.58	2.59	1.86	0.77	1.21	1.53	2.11	2.27	---	----	1.46	----	2.48
C.P. in Fluid D.M.,%	30.2	35.6	33.8	27.1	24.1	30.6	23.6	31.8	24.1	23.3	---	----	32.3	----	23.3
C.F. in Fluid D.M.,%	3.9	5.9	2.6	7.3	6.7	7.2	2.2	1.8	3.8	5.9	---	----	4.38	----	5.5
Ash in Fluid D.M.,%	39.9	30.3	38.8	38.0	43.7	34.5	30.8	34.7	37.3	39.0	---	----	32.9	----	40.7

¹ 1 = Farrowing Barn
 2 = South Nursery
 3 = North Nursery
 4 = South Finishing Barn
 5 = North Finishing Barn

²Hydrant water = 53⁰ F.

^aDry Matter

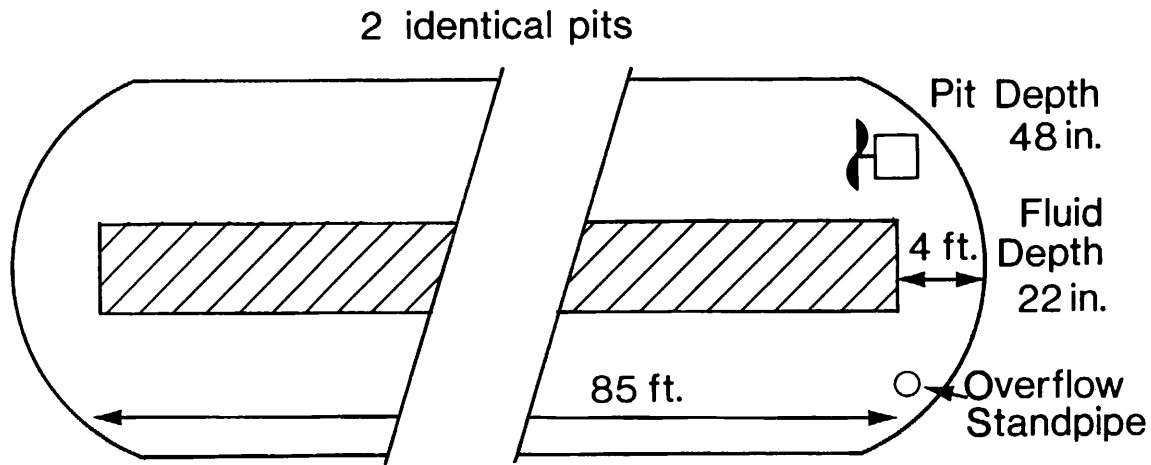

NURSERY BARN

Figure 11.1.
General Design Information

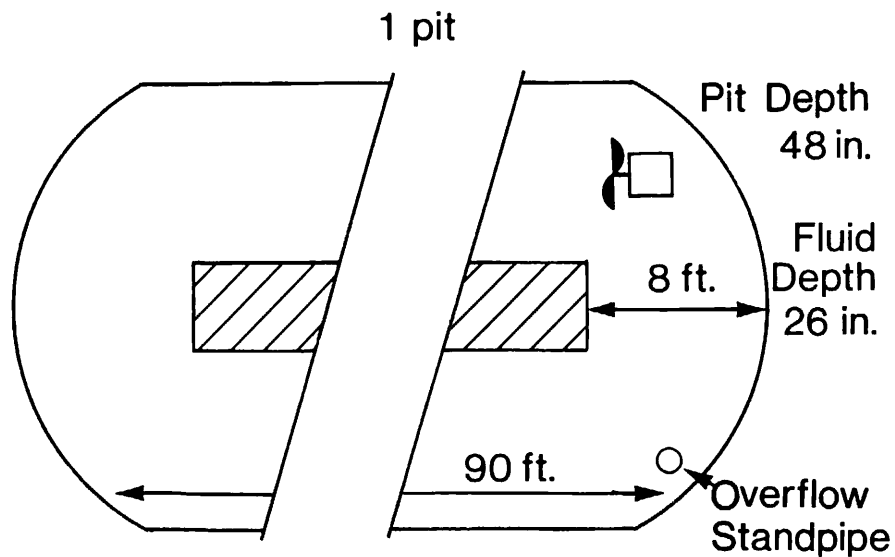

FARROWING BARN

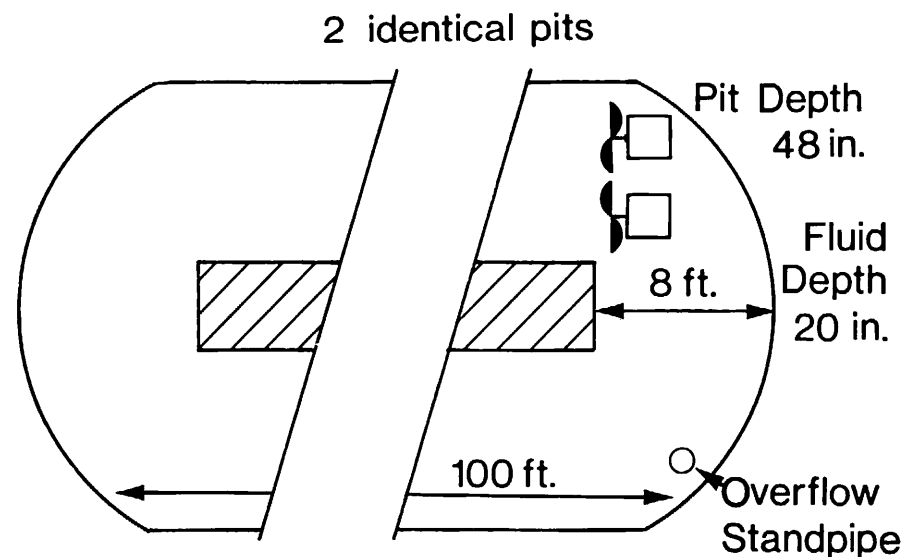

FINISHING BARN