

PHOTOPIC & SCOTOPIC LIGHT PERCEPTION

by

MICHELLE A. BELL

B.S., Kansas State University, 2010

A REPORT

submitted in partial fulfillment of the requirements for the degree

MASTER OF SCIENCE

Department of Architectural Engineering and Construction Science  
College of Engineering

KANSAS STATE UNIVERSITY  
Manhattan, Kansas

2010

Approved by:

Major Professor  
Fred Hasler

## **Abstract**

This paper discusses photopic and scotopic vision of the human eye and the implications that could result in the design process of the lighting industry. The incorporation of scotopic vision in lighting affects the perceived illumination in all settings; but these effects and benefits are seen more prevalently at night, as this is when scotopic vision is utilized by the eye the most.

The paper will begin with an overview of the eye including discussions of exactly what photopic and scotopic vision are, as well as how the eye works. This will lay a foundation for the paper to help the reader better comprehend and understand the remainder of the content. After the groundwork has been laid, the factors that affect how the eye perceives light will be discussed. These factors include pupil size and color of the light. A discussion of the basis for current lighting industry design and how light levels are measured will follow. Once these topics have been fully explored, there will be a discussion of the changes that could occur in the lighting industry if scotopic vision is taken into account. Increased energy efficiency would result if the scotopic vision is incorporated, resulting from the decrease in needed total lumen output. There have been a few applications that have utilized the effects of the scotopic vision in their design, these cases will be presented. Following the case study discussions, will be a discussion of a survey conducted by myself on the change-out of high pressure sodium (HPS) fixtures to LED fixtures in the downtown Poyntz Avenue area of Manhattan, KS. After all studies have been reviewed, conclusions and correlations among them will be explored. Following this analysis, suggestions will be given to improve the way lighting is designed in the industry.

## Table of Contents

List of Figures .....	v
List of Tables .....	vi
Acknowledgements .....	vii
Chapter 1 - Introduction .....	1
Chapter 2 - How the Eye Works .....	2
Types of Vision .....	5
How the Eye Moves Through the Types of Vision .....	6
How the Eye Adapts .....	6
Chapter 3 - Factors Influencing the Way Light is Perceived .....	8
Chapter 4 - How the Lighting Industry Currently Defines/Measures Illumination .....	9
Current Luminance Meters in Industry .....	10
Chapter 5 - How the Industry Could Change .....	11
A New Photometry System .....	11
A New Luminance Meter .....	15
Chapter 6 - Review of Case Studies .....	20
Warehouse Relamping .....	20
Intel Corporation Retrofit .....	21
Raleigh, NC, Parking Garage .....	21
IES Study .....	22
Lamp Type Comparisons .....	23
Narrowband Fluorescent v. Cool-White & Warm White Fluorescent .....	23
Incandescent v. High Pressure Sodium .....	24
High Pressure Sodium v. Cool White Fluorescent .....	24
Fluorescent Color Temperature .....	25
LEDs .....	25
Suggestions .....	26
Chapter 7 - Manhattan, KS Case Study .....	27
Background .....	27

Overall Results.....	28
Results on Illumination.....	29
Distinguishability and Color Rendering.....	31
Safety and Feeling of Comfort.....	31
Facades and Signage.....	33
Sidewalk Illumination Results.....	34
Participant Comments.....	34
Survey Conclusions.....	35
Further Investigations.....	38
Chapter 8 - Relationships Among Case Studies.....	39
Chapter 9 - Suggested Industry Improvements.....	40
Chapter 10 - Conclusion.....	41
Bibliography.....	42
References.....	44
Appendix A - Poyntz Avenue Survey; Manhattan, KS.....	45
Appendix B - Survey Results - Quantities.....	47
Appendix C - Survey Results - Percentages.....	51
Appendix D - Poyntz Avenue CAD Drawing.....	53
Appendix E - Existing HPS Fixture Luminance Measurements.....	54
Appendix F - Replaced LED Fixture Luminance Measurements.....	55
Appendix G - Cut-Sheet, Poyntz Existing HPS Fixture.....	56
Appendix H - Cut-Sheet, Poyntz Proposed LED Fixture.....	60

## List of Figures

Figure 2.1 Human Eye Diagram (Erdman, n.d.).....	2
Figure 2.2 Scotopic and Photopic Wavelength Sensitivity Graph (Turlej, 2000) .....	3
Figure 2.3 Cone Sensitivity Graph (“Eye Spectral”, n.d.).....	4
Figure 2.4 Dark Adapt Graphical Depiction (Green, 2009) .....	7
Figure 5.1 S/P Ratios of Various Lamps .....	13
Figure 5.2 S/P Ratios of Selected Lamps (“Visually Effective”, 2010) .....	16
Figure 5.3 RFD Meter Schematic Diagram (Van Derlofske et al., 2002) .....	17
Figure 6.1 Warehouse Before and After Relamping (“Scotopic”, 2010) .....	20
Figure 6.2 Parking Garage Before and After (“Survey Shows”, n.d.).....	22
Figure 7.1 Light Fixtures on Poyntz Avenue; Manhattan, KS .....	28
Figure 7.2 Percentage Results of Participant Preference, Poyntz Avenue .....	30
Figure 7.3 Average Results of Ratings, Poyntz Avenue.....	32
Figure 7.4 Poyntz Avenue.....	34

## List of Tables

Table 5.1 40W Fluorescent Lamps (Berman, “Energy”, 1992).....	12
Table 5.2 40W Fluorescent Comparison (Berman, “Energy”, 1992).....	14
Table 5.3 125W Incandescent v. 35W HPS Comparison (Berman, “Energy”, 1992).....	14
Table 6.1 Fluorescent Comparison (Berman, “Energy”, 1992).....	23
Table 6.2 Comparison of Incandescent and High Pressure Sodium Lamps (Berman, “The Coming”, 2000).....	24
Table 6.3 32W T8 Fluorescent Lamp Comparison.....	25
Table 6.4 LED Comparison (Peng et al., 2009).....	26
Table 7.1 HPS Illuminance Measurements (fc).....	36
Table 7.2 LED Illuminance Measurements (fc) .....	36
Table 7.3 Energy Consumption .....	37

## **Acknowledgements**

I would like to extend a big thank you to Fred Hasler for serving as my Major Professor and also for all his assistance throughout the process of completing this paper. I would also like to thank Tom Logan and Ray Yunk for serving on my Master's Committee. I enjoyed working with all of you and appreciate the time and effort you put into this. Also, I would like to thank my family and friends, and in particular my parents, for all their support and encouragement. Lastly, I would like to acknowledge the authors noted in the bibliography and reference sections of this paper for their hard work and effort in the subject.

# Chapter 1 - Introduction

In the lighting industry, one of the design goals is to have the lowest possible power density while still providing adequate illumination of the space. This keeps the operating cost low for the owner as well as reducing overall energy consumption. The way the human eye perceives light factors into this and a better understanding of it has the potential to make a large impact in the lighting industry.

There are many factors that influence the way light is perceived. This paper will discuss those factors after first giving an overview of how the human eye works. The eye's make-up has a large effect on how light is perceived by the human eye. To fully understand and get the most benefit possible out of a lighting design, the functions of the eye must be understood.

The paper will then follow up with how the industry currently bases its design of lighting, review case studies, and discuss a survey conducted in Manhattan, KS. The case studies will examine the advantages of scotopically enhanced lamps and the corresponding benefits. These include: increased patron satisfaction, reduced energy consumption, decreased operating cost, and short return on investment. In addition, comparisons will demonstrate how to fully analyze lamps to choose the best possible solution for the given application.

Next, relationships among studies will discuss the main aspects and design concepts affecting lighting and the incorporation of scotopic vision. This will allow for suggestions of how to improve the industry to be presented.

The changes needed to integrate scotopic vision into lighting design to more accurately match the way the human eye perceives light are simple and will greatly advance and improve the lighting industry in many ways.



## Chapter 2 - How the Eye Works

The eye is composed of many parts, but it is the rods and cones that sense light. The peripheral area of the fovea (the center of the retina) contains both rods and cones in a ratio of 10:1. Rods are responsible for scotopic vision while cones are responsible for photopic vision (Erdman, n.d.). The following is a diagram of the eye to better describe its functionality.

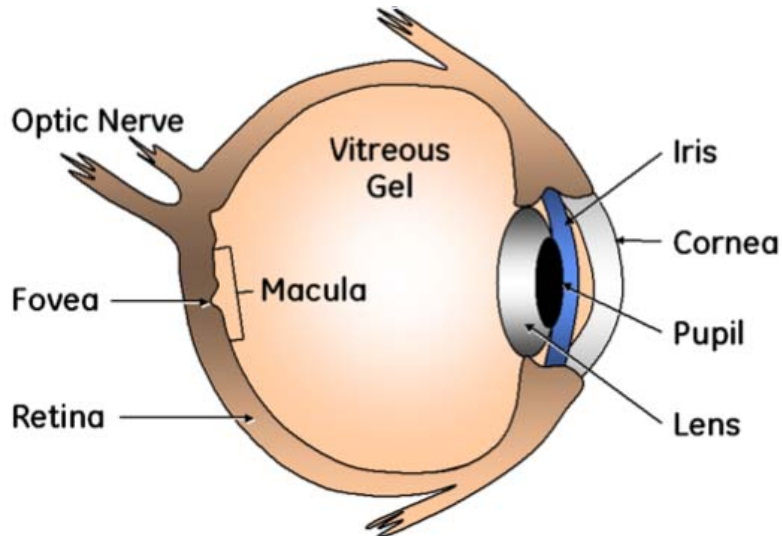
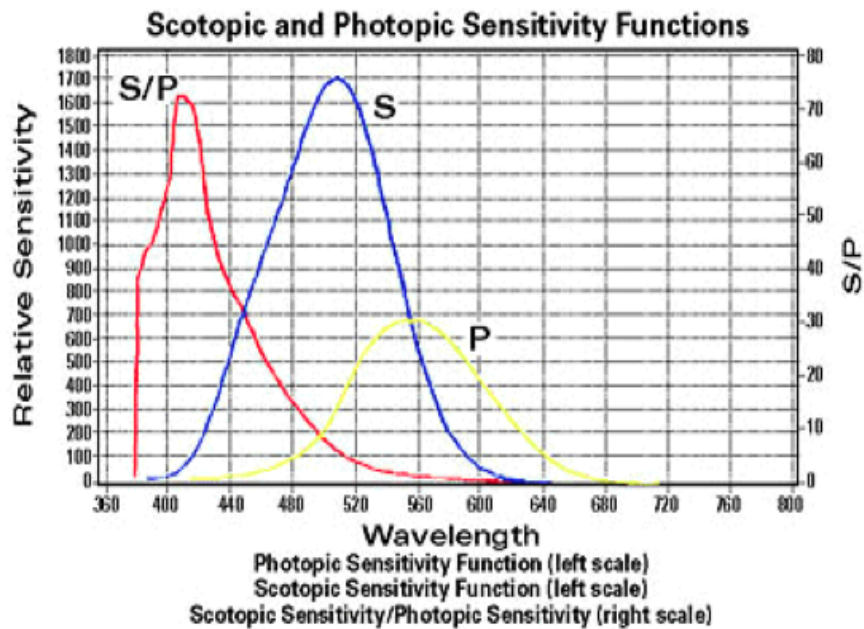

**Figure 2.1 Human Eye Diagram (Erdman, n.d.)**

The retina is located at the back of the eye, as can be seen from the preceding diagram, Figure 2.1, and contains both rods and cones, with the center containing densely packed cones. In the eye, cones are found mainly in the eye's fovea falling in a  $2^\circ$  area; this is only 0.02% of the total human visual field (Turlej, 2000). The rods are located away from the fovea, with the maximum density area 10 to  $20^\circ$  off of the foveal axis. As a result of the rods not being located in the center of the eye, they are not utilized much when looking directly at objects. Peripheral vision employs mainly the rods ("Some Issues", 1996), while cones are the part of the eye that help in seeing fine detail and color (Berman, "Energy", 1992).

Another important aspect to note about rods and cones is that cones have a higher visual acuity than rods. This means that the eye sees less detail with rods; however, rods are able to pick up motion well ("Some Issues", 1996). Cones peak in the yellow-green spectrum of 555 nanometers, while the rods peak in the bluish-green spectrum at 505 nanometers. As you can see, rods and cones differ in sensitivity to color, as demonstrated in Figure 2.3 (Erdman, n.d.). The

wavelength sensitivities of the three types of vision can be seen in the following graph, Figure 2.2 (Turlej, 2000).



**Figure 2.2 Scotopic and Photopic Wavelength Sensitivity Graph (Turlej, 2000)**

The reason for the difference is that cones and rods contain different photo-pigmentation (Berman, "Energy", 1992). Rods and cones cannot be fully separated, as they both play a role in light perception ("Scotopic", 2010). An inverse relationship exists between cones and rods; cones contribute to vision less when there is a low amount of illumination, while rods contribute to vision more during this time (Yaguchi, 2006).

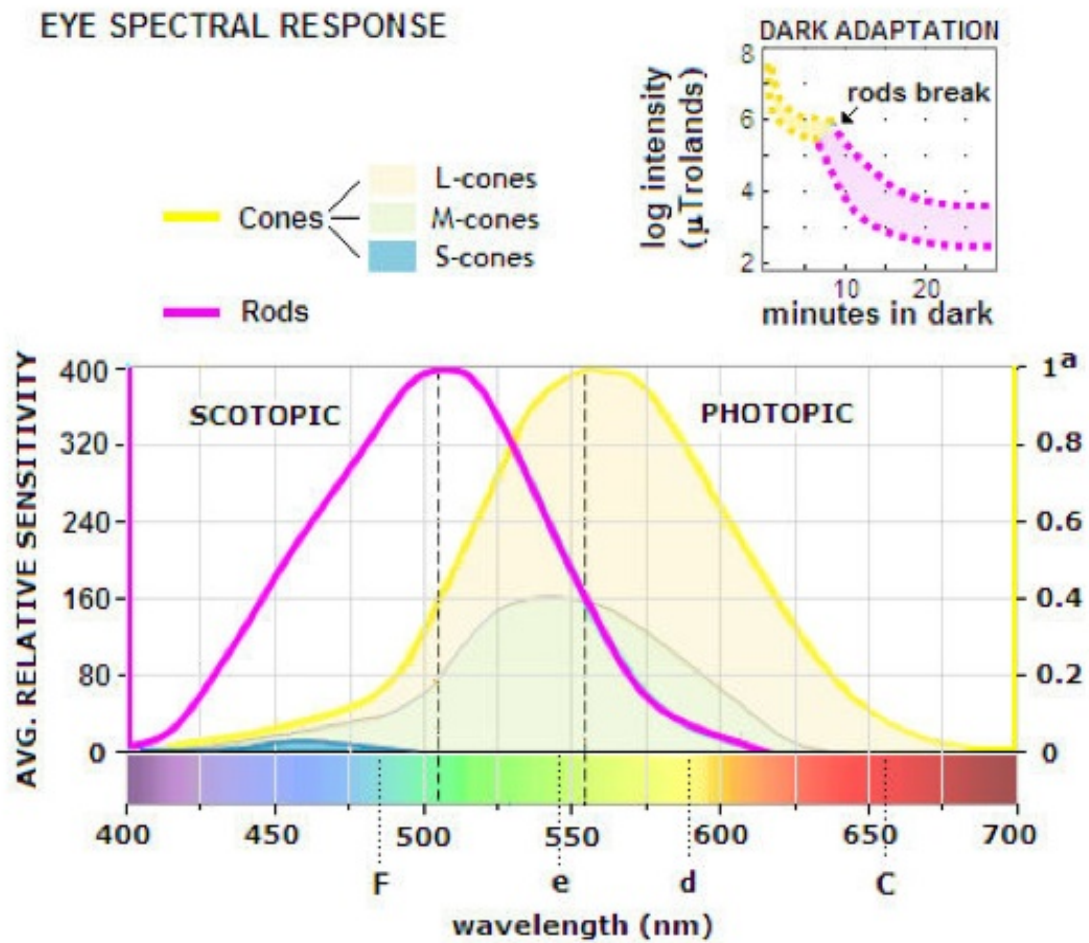

**Figure 2.3 Cone Sensitivity Graph (“Eye Spectral”, n.d.)**

There are three types of cones: L-cones, which are long-wavelength sensitive; M-cones, which are mid-wavelength sensitive; and S-cones, which are short-wavelength sensitive (“Eye Spectral”, n.d.). Figure 2.3 shows the wavelength sensitivity of the three cone types.

S-cones are the least numerous among the three types, as well as the least sensitive. The main responsibility of the S-cones is to relay the color blue. There are no S-cones on the fovea, therefore the fovea is considered to be blue blind (“Eye Spectral”, n.d.).

L- and M-cones are the primary input for luminance and are located in large numbers on the fovea. These L- and M-cones influence the spectral sensitivity of the eye (Schanda, Morren, Rea, Rositani, & Walraven, 2002).

Direct object detection identifies objects in the immediate area and does not depend on brightness; direct object detection relies on the fovea of the eye, therefore it utilizes the photopic vision as the fovea contains cones only (Josefowicz & Ha, 2008).

Spacial brightness perception utilizes rods and cones found on the retina. This means that spacial brightness perception is in both photopic and scotopic vision, also known as mesopic vision. Spacial brightness perception is how bright the illumination is perceived to be in a broad area, which can affect how safe people feel in that area; this aspect is important to consider when designing lighting (Josefowicz & Ha, 2008). Beyond a 5° range, visual acuity decreases due to a decrease in the density of the cones; therefore spectral sensitivity changes with retinal eccentricity (Schanda et al., 2002).

It has been stated that cones are more responsible for day vision while rods are more responsible for night vision (“Scotopic”, 2010). In dim light, such as nighttime, there is not enough light to activate the cones and therefore creates an absence of color perception; but there is enough light to activate the rods, as stars are visible in the sky when there is no cloud cover (Berman, “Energy”, 1992). In low light levels, the eyes perceive only brightness as a result of there not being enough illumination to activate the cones (“Some Issues”, 1996). Rods are mainly responsible for night vision, but also contribute to other vision as well (Berman, “Energy”, 1992) and are the primary control for the closing and opening of the pupil (Berman, “The Coming”, 2000).

## **Types of Vision**

There are three types of vision that enables the eyes to see. The first is photopic vision, in which the cones in the eye are activated. This generally occurs during the day and in areas with high levels of illumination (Josefowicz & Ha, 2008). Photopic vision is also characterized by high acuity, color vision, and low light sensitivity (Green, 2009). Scotopic vision is the second type of vision and is characterized by low light levels; this type of vision is used at night (Josefowicz & Ha, 2008). Scotopic vision is also characterized by poor acuity, no color vision, and high light sensitivity (Green, 2009). The final type of vision is called mesopic vision and is characterized as an in-between vision where both the rods and cones are utilized (Josefowicz & Ha, 2008). Vision at night occurs in the mesopic vision where there is a mixing of rod and cone use. While in the mesopic range, the bottom of the cone and the top of the rod operating levels

overlap. As the eye transitions into mesopic vision, the contrast sensitivity declines rapidly (Green, 2009).

### ***How the Eye Moves Through the Types of Vision***

The eyes must be able to transition between the different types of vision. During the day, the eyes utilize photopic vision when there is plenty of light available; this is ideal for seeing contrast. As the day progresses, the light levels change and the eyes have to adjust for that. The eyes operate by inhibition and then slowly switch over to convergence. When the eyes are functioning in convergence, the outputs from the rod and cone receptors are summed together. This increases sensitivity, but reduces the resolution. So therefore in dim light, the eyes have greater sensitivity to light (“Some Issues”, 1996). Vision at night differs from vision during the day. At night, vision has a lower saturation and shifts towards a blue intensity; there is also some loss in visual acuity (Ning, Weiming, Jiaxin, & Jean-Claude, 2009).

### **How the Eye Adapts**

There are four different adaptations the eyes go through. These adaptations occur during two time phases, the slow phase and the transient phase. The slow phase takes about 45 minutes while the transient phase occurs in only about a second or more (Green, 2009).

The first adaptation is referred to as “dark adapt”. This occurs when going from a bright to dark space and happens at a slow or transient phase. The eyes also go through “light adapt” when going from a dark to bright space. Both of these can also occur at a slow phase or a transient phase. Consequently, the four types of adaptation are: dark adapt slow phase, dark adapt transient phase, light adapt slow phase, and light adapt transient phase. During the transient phase, the sudden change in illumination causes a significant impairment on vision. The purpose of the transient phase is to adjust the eyes enough to allow for adequate functioning during the slow phase. The graph on the following page, Figure 2.4, depicts what happens in the eyes during slow phase dark adaptation; as time progresses, the sensitivity of the rods and cones change (Green, 2009).

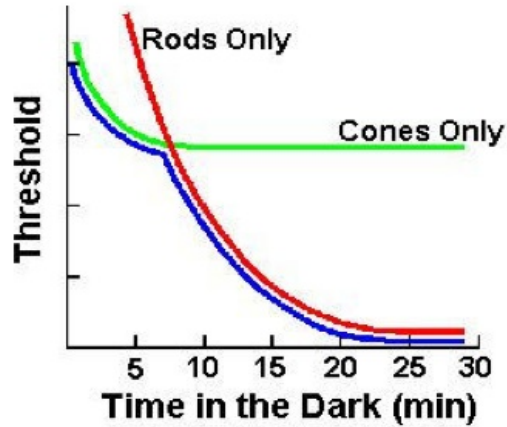

**Figure 2.4 Dark Adapt Graphical Depiction (Green, 2009)**

As can be seen from the graph above, initially it is the cones that are adapting aggressively. During the beginning of the adaptation, the lower bound, which is depicted by the blue line, is being set by the cones, the green line. After about five minutes, the lower bound is set by the rods, the red line. This occurs because the eyes are adapting from light to dark and the cones are more active in light. As time progresses, the cone sensitivity levels off and the rods begin to adapt. At this point, the rods start to set the lower threshold of vision. The duration of the adaptation varies depending on the level of initial adaptation and the final level of adaptation, as well as wavelength, amount of time in the bright light, and area of the retina. The adaptation process can take up to 45 minutes (Green, 2009).

## Chapter 3 - Factors Influencing the Way Light is Perceived

Many factors can have an influence on the way the human eye perceives illumination; two factors that carry more weight are color rendering of the lamp and pupil size. Both aspects of vision, pupil size and color of the light, are important in visual performance. These factors can then impact several other aspects contributing to perception.

The first of the main factors that influences the way the human eye perceives brightness is the color rendering of the light source. More energy is required in the blue/red spectrum than in the yellow/green spectrum to achieve the same photopic illuminance (Erdman, n.d.).

Pupil size also has an effect on the way light is perceived (Schanda et al., 2002) and is controlled by the scotopic luminance level (Berman, "Energy", 1992). This means that the pupil size is controlled mainly by the rods (Berman, "The Coming", 2000). The size of the pupil influences visual acuity, the ability to determine fine detail and depth of field, and the ability to maintain the focus of objects over a range of distances. Increases in luminance level will generally decrease pupil size. A larger pupil in a moderate to low contrast setting results in reduced visual acuity. In a study done by Campbell, Ogle, Schwartz, Tucker, and Charman, a larger pupil also resulted in a decrease of depth of field. Therefore, it can be seen that a smaller pupil is beneficial for vision, as a smaller pupil size results in an increase of visual acuity and an increased improvement of depth of field (Berman, "Energy", 1992). This can in turn result in an increase in brightness perception.

White light that is more in the blue-green spectral distribution will be more efficient in decreasing pupil size than lighting that is lacking blue-green spectral distribution (Berman, "Tuning", 1992). A higher visual performance can be achieved with a light source high in the blue power distribution, as it appears brighter ("Some Issues", 1996).

Visual clarity is the result of a combination of advantages from scotopically rich illumination, these advantages include: increased brightness perception and an increase in depth of field. Increased color temperature of a light source correlates to a higher S/P value (the ratio of scotopic lumens to photopic lumens) and in turn results in increased visual clarity and decreased pupil size. Smaller pupil size also results from an increase in vertical luminance in the periphery (Berman, "Energy", 1992).

## Chapter 4 - How the Lighting Industry Currently Defines/Measures Illumination

Because of the way luminance levels are currently measured, light sources with equal amounts of illumination can have differing brightness and clarity of brightness due to their varying color characteristics.

Light levels are currently measured based on brightness matching (Turlej, 2000), which is the amount of photopic lumens emitted by a light source (“Scotopic”, 2010). This means that current luminance meters only take into account the cone sensitivity of the eye (Berman, “Tuning”, 1992). Different applications need different luminous efficiency functions. Acuity can be characterized using a simple additive luminous efficiency function, while brightness cannot be characterized using such a simple luminous efficiency function.

There are three basic luminous efficiency functions that are used commonly:  $V(\lambda)$ ,  $VM(\lambda)$ , and  $V10(\lambda)$ . These efficiency functions cannot be used for perceived brightness (Schanda et al., 2002). Photopic luminous efficiency functions are based on the cones which have the functions  $V(\lambda)$ ,  $VM(\lambda)$ , and  $V10(\lambda)$ . Scotopic luminous efficiency is based on the sensitivity of the rods and has the function  $V'(\lambda)$ . Currently the photopic luminous efficiency function,  $V(\lambda)$ , is what is used commercially to characterize the performance of lighting products.  $V'(\lambda)$  is not used commercially, only in the academic arena to characterize light sources in very dim starlit conditions (Rea & Bullough, 2007).

$V(\lambda)$  does not work well for most outdoor lighting applications, as the luminance levels are not high enough for cone-only vision. Outdoor lighting applications are more suited for the mesopic region of vision (Rea & Bullough, 2007). The  $V(\lambda)$  luminous efficiency function does however work well for: acuity, reaction times, flicker, apparent movement minimization, and minimally distinct borders. The  $V(\lambda)$  luminous efficiency has been used since 1924 to characterize illumination. It was believed that all aspects of lighting – brightness, acuity, flicker, and photometry – all follow the same laws; this has been proven to not be true in many studies and surveys that have been completed (Schanda et al., 2002).

The difference between the  $V(\lambda)$  and  $VM(\lambda)$  efficiency functions is generally unimportant for foveal tasks. There are a few instances where this does matter; for example, this difference



matters for narrow band sources that only emit short wavelengths. To get a more accurate sense of the perceived illumination, it is better to use the  $VM(\lambda)$  efficiency function than the  $V(\lambda)$  efficiency function currently used by manufacturers. A more important difference for light sources with short wavelengths, including white light sources and daylight fluorescents, is between the  $V(\lambda)$  and the  $V10(\lambda)$  luminous efficiency functions. The importance results from the color matching of the visual fields (Schanda et al., 2002).

The difference between  $V(\lambda)$  and  $VM(\lambda)$  is more noticeable for LEDs. These luminant sources are becoming more prevalent in industry and, as a result, the incentive to change the measurement system and industry standards will increase (Schanda et al., 2002). Various light sources produce differing amounts of energy per wavelength over the visual spectrum. These differences in spectral output are not taken into account as lamps are measured on their photopic lumen output (Berman, “Energy”, 1992).

Scotopic and rod response has been assumed to be irrelevant. This is not necessarily true as the rods are responsible for pupil size, which has an effect on the eye’s perception of illuminance. Currently, the industry tries to reduce pupil size by increasing luminance levels. This method is inefficient and does not take advantage of the rods’ effect on pupil size, and in addition adds glare. A solution would be to choose a scotopically enhanced lamp, meaning to choose a lamp that has a higher color temperature; this will in turn activate more rods (Berman, “The Coming”, 2000).

### **Current Luminance Meters in Industry**

Luminance meters used today are calibrated to the 1951 CIE Colour Space Standards (“Visually Effective”, 2010). This standard is based on the spectral luminous efficacy function,  $V(\lambda)$ , which is good for visual acuity and therefore is a good measure of task-performance, but is not good for evaluating brightness (Schanda, 1997). This standard does not take into consideration scotopic vision and relies solely on photopic vision. It has been found that the eye is more sensitive to blue wavelengths than what current light meters are calibrated to and therefore the readings are not truly what the eye sees (“Visually Effective”, 2010).

## Chapter 5 - How the Industry Could Change

There are several ways the industry could change for the better by incorporating scotopic vision in addition to photopic vision already being utilized. The lumen output of a lamp is currently obtained by averaging the wavelength spectral power distribution over the photopic visual efficiency of the eye. Therefore an incandescent lamp and a fluorescent lamp could have equal photopic luminance levels measured with the current luminance meters used in industry, although the illumination from the two lamps may actually be very different (Berman, “Energy”, 1992). A new photometry system enhanced with scotopic vision could be used as well as a new type of luminance meter.

### A New Photometry System

A photometry system to measure luminance could be used that unifies photopic, scotopic, and mesopic perceptions (Rea, Bullough, Freyssinier-Nova, & Bierman, 2004). Luminance sources that have a richer spectral content in the scotopic region need less photopic luminance to give the same visual performance, clarity, and brightness. If the spectrum of the lamp is taken into consideration, there is a great opportunity for energy efficiency and cost-effective design (Berman, “Energy”, 1992).

Using the knowledge of how pupil size affects our vision, a reduction in lighting energy can be achieved without reducing visual effectiveness. This can be realized by assuming the existing lighting condition of a space provides a satisfactory level of illumination. By changing the spectrum of the lamping while maintaining the pupil size created by the existing condition, the energy consumption can be reduced as a result of selecting a different lamp with higher scotopic lumens per watt (Berman, “Energy”, 1992).

Pupil lumens are a more accurate measure of output lumens. Pupil lumens are obtained using the equation  $P(S/P)^{0.78}$ , where P=photopic lumens and S=scotopic lumens. The ratio of scotopic to photopic lumens is known as the S/P ratio and is a property of the lamp’s spectral power distribution. The pupil lumens of a few lamps can be observed in Table 5.1 that follows along with photopic lumens, scotopic lumens, and pupil lumens per watt. (Berman, “Energy”, 1992)

Lamp	Photopic Lumens	Scotopic Lumens	Effective pupil lumens P(S/P) <sup>.78</sup>	Relative power, level for equal pupil size	Pupil lumens per watt
Warm-white fluorescent	3200	3100	3125	136	78
Cool-white fluorescent	3150	4630	4254	100	106
Narrow-band phosphor fluorescent (5000K)	3300	6468	5578	76	139
Scotopically rich narrow-band	3000	7500	6130	69	153

**Table 5.1 40W Fluorescent Lamps (Berman, “Energy”, 1992)**

To obtain smaller pupil size and a brighter perception of light, a scotopically rich illumination is the preferred spectrum. The high scotopic output also results in a more cost effective lamp based on input power. Higher visual clarity results from larger scotopic illuminance, most likely resulting from the decreased pupil size and increased depth of field (Berman, “Energy”, 1992).

By implementing the S/P ratio, economic benefits including energy savings could be realized while maintaining a high visual effectiveness (Turlej, 2000). The following chart, Figure 5.1, found on the next page gives S/P ratios for various lamps in industry.

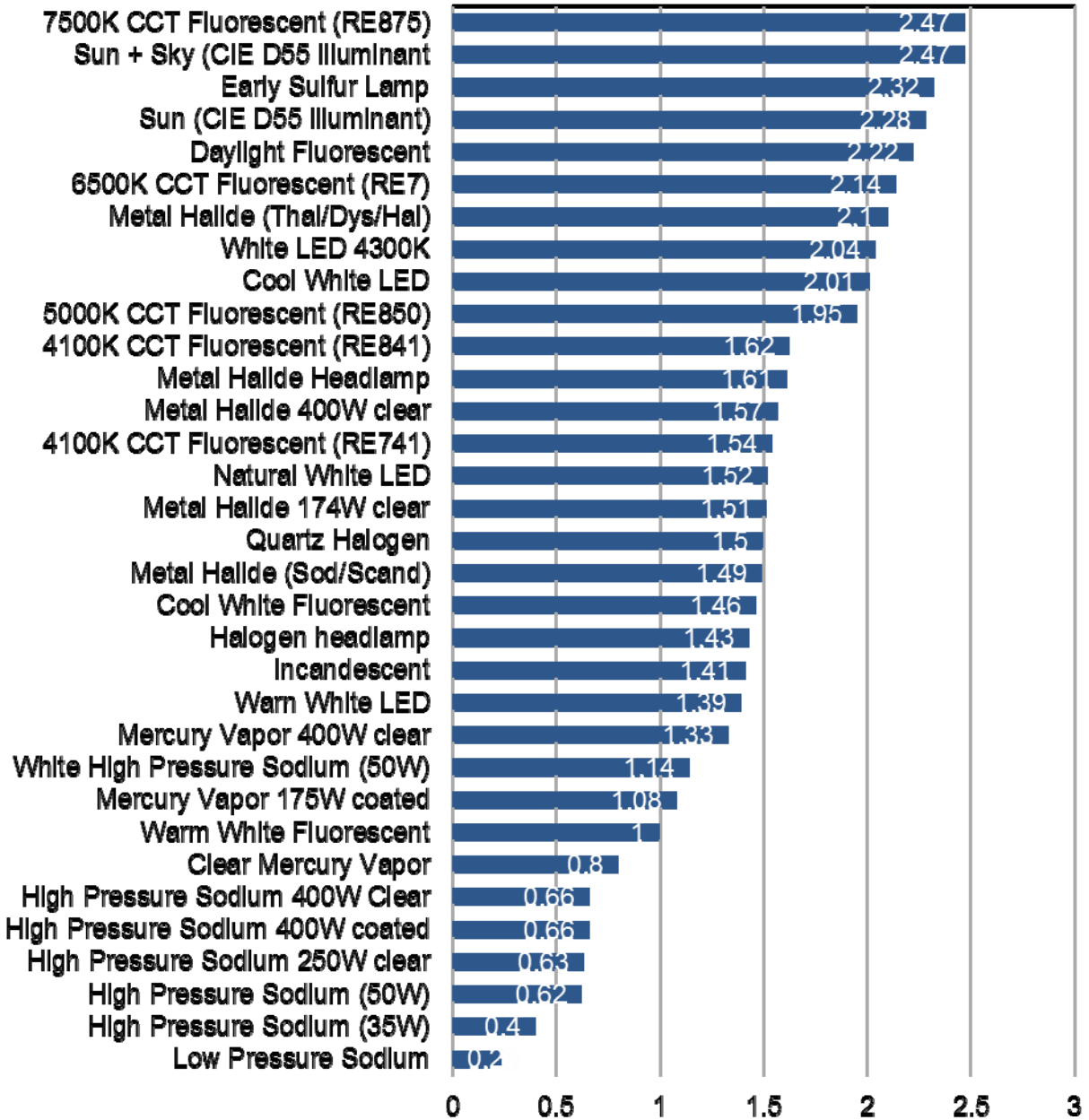

**Figure 5.1 S/P Ratios of Various Lamps**

Some lighting manufacturers believe that photopic and scotopic lumens can be added together, with the result of a higher efficacy and lower energy input to achieve the desired lumens; this is not accurate. It is good that manufacturers are trying to adjust to a new way of doing things, but they need to go about it the right way. Photopic and scotopic lumens cannot just be added together; there needs to be some additional calculations and weighting as previously discussed. The spectral power density must be weighted by the photopic or scotopic

response of the eye for a more realistic lumen output. Higher lighting efficiencies will still be achieved using this method (Josefowicz & Ha, 2008).

Lamp	Photopic lumens	Scotopic lumens	Effective pupil lumens [P(S/P).78]	Relative Power level for equal pupil sizes	Pupil lumens per watt
Warm-white fluorescent (WW)	3200	3100	3125	136	78
Cool-white fluorescent (CW)	3150	4630	4254	100	106
Narrow-band phosphor fluorescent (5000 K) [NB(5000)]	3300	6468	5578	76	139
Scotical rich narrow band (SR-NE)	3000	7500	6130	69	153

**Table 5.2 40W Fluorescent Comparison (Berman, “Energy”, 1992)**

From the preceding chart it can be identified that the narrow band fluorescent uses 24% less energy than the cool-white lamp and 44% less energy than the warm-white fluorescent. At first glance a lamp could look much more efficient when comparing lumens per watt, when in fact it is actually about the same when looking at pupil lumens per watt. It is important to take all aspects into account when selecting a lamp type. For example, when looking at a 125W Incandescent lamp versus a 35W High Pressure Sodium (HPS) lamp, one would think that the HPS lamp would be the more efficient choice when in fact this is not the case. The HPS does have a much higher lumen per watt rating, but the pupil lumens per watt are about the same, which is what the human eye actually perceives. The HPS lamp does not create an atmosphere conducive to small pupil size. Because of the pupil size, it requires the same power level for both lamps to create equivalent visual effectiveness. This is demonstrated by the following table (Berman, “Energy”, 1992).

Lamp (2250 lumens)	Lumens per watt	Ratio S/P	Relative Power level for equal pupil size	Pupil lumens per watt
125-W incandescent	18	1.4	100	23.4
35 Watt HPS	50*	0.4	96	24.5

\*(10 W for ballast is included)

**Table 5.3 125W Incandescent v. 35W HPS Comparison (Berman, “Energy”, 1992)**

LEDs are available in various color temperatures, which means that their scotopic luminance is different and therefore their efficiencies are different as well. This is due to the ratio of active cones and rods in the eye (Peng, Yi-feng, Qi-feng, Rooymans, & Chun-yu, 2009). This means that each LED will have different S/P ratios correlating to their color temperature, in turn giving each LED a different value for pupil lumens per watt. It is therefore important to take into considerations the color temperature of lamps.

No photometry system will exactly mimic the way the human eye perceives light, but incorporating scotopic vision into the system will get us much closer. This has the potential to reduce light pollution, reduce glare, reduce energy used on lighting, and improve safety. The implementation of this new system of photometrics would bring about an immediate improvement in outdoor lighting, as this is where the scotopic region is used and activated the most. In order for a change to be implemented into industry, it should be easy to apply and not require additional photometric equipment (Rea & Bullough, 2007).

### **A New Luminance Meter**

A new way of measuring luminance would have a large impact on the lighting industry. This could be accomplished by using luminance meters that determines both photopic and scotopic illuminances (Berman, “The Coming”, 2000).

As discussed in the previous section, there is a way to get this same result from a conventional luminance meter: by using the ratio of scotopic to photopic quantities, the S/P value. Most S/P values are in the range of 1 to 2.3, while high pressure sodium lamps have an S/P value of 0.6 and low pressure sodium lamps have an S/P value of 0.4. Each lamp has a specific S/P ratio; this value can be used in addition to the photopic lumens measured by current luminance meters in the equation  $P(S/P)^{0.78}$  to give a lumen output closer to what is perceived by the human eye. This method creates the possibility for calculation errors, but is an option that can be utilized until new luminance meters are commonly used. The following chart shows the S/P values of some common lamps used in industry (Berman, “The Coming”, 2000).

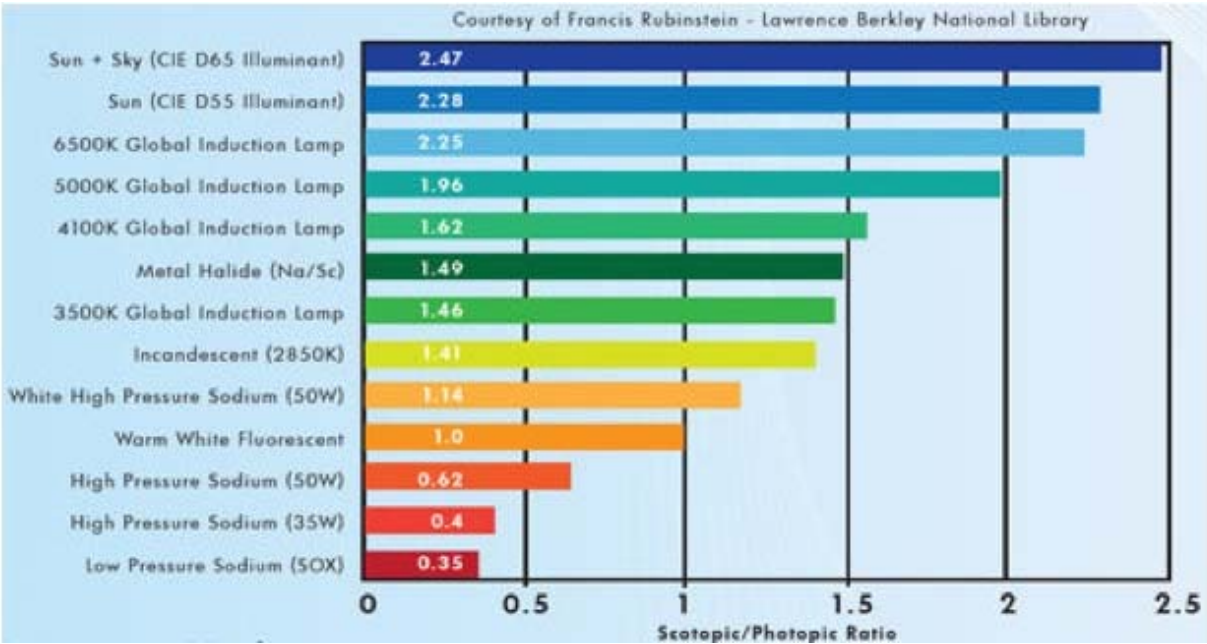

**Figure 5.2 S/P Ratios of Selected Lamps (“Visually Effective”, 2010)**

An alternative to using the S/P value would be to use a luminance meter that utilizes scotopic luminance in its measurement; this would be a retinal flux density (RFD) meter. An RFD meter is capable of measuring illuminance just as current luminance meters do and can measure the flux density on the retina of the eye; this option incorporates photopic and scotopic vision into the reading. It is believed by some that a large change in the industry will not occur until an inexpensive and useful meter has been developed to measure the flux density at the mesopic luminance level, this being the RFD meter (Van Derlofske, Bierman, Rea, Ramanath, & Bullough, 2002).

Luminance meters used most commonly in industry are illuminance-based and cost around \$500; these meters are accurate to within 5%. RFD meters are approximately \$2000 because of their higher optical sophistication. The cost of the RFD meters is part of the reason why the current luminance meters are used to comply with standards of design. If the cost of RFD meters drop below \$1000 it could allow more people to use them, and therefore have a large impact on the lighting industry (Van Derlofske et al., 2002).

$V(\lambda)$  is the photopic luminous efficiency function, as stated previously in the paper, and represents the spectral sensitivity of L- and M-cones.  $V(\lambda')$  is the scotopic luminous efficiency function, which is a representation of the spectral sensitivity of the rods located in the peripheral

retina area.  $V(10\lambda)$  is a representation of the cones located on the retina out to ten degrees.  $V(\lambda)$  does not take into account the spectral sensitivity found on the peripheral retina at low light levels, such as those found in outdoor applications (Van Derlofske et al., 2002).

The housing of the RFD metering device has been created to mimic the spectral efficiency of the eye, allowing measurement of flux density similar to the retina. The meter is constructed with photosensitive diodes and a beam splitter so that  $V(\lambda)$  photopic and  $V(\lambda')$  scotopic retinal flux density can be measured simultaneously. With this meter,  $V(10\lambda)$  peripheral photopic luminance can be measured when utilizing a software program. Mesopic measurements can also be obtained, depending on the light levels (Van Derlofske et al., 2002).

An RFD meter is a very useful meter with a lot of capabilities; unfortunately, this is newer technology and costs are prohibitive. The price and unfamiliarity make it uncommon in the industry. If use of this meter became widespread, it could have a big impact on the industry and lead to changes and new standards which could ultimately lead to improved efficiency and increased safety at night (Van Derlofske et al., 2002).

The RFD meter is composed of several parts to allow it to behave like a human eye. These parts include: a cylindrical housing, a cylindrical baffle, a lens system, a decentered aperture, an optical diffuser, a beam splitter, a photopic filter, a scotopic filter, and two silicon photodiodes. Below is a diagram, Figure 5.3, of these components (Van Derlofske et al., 2002).

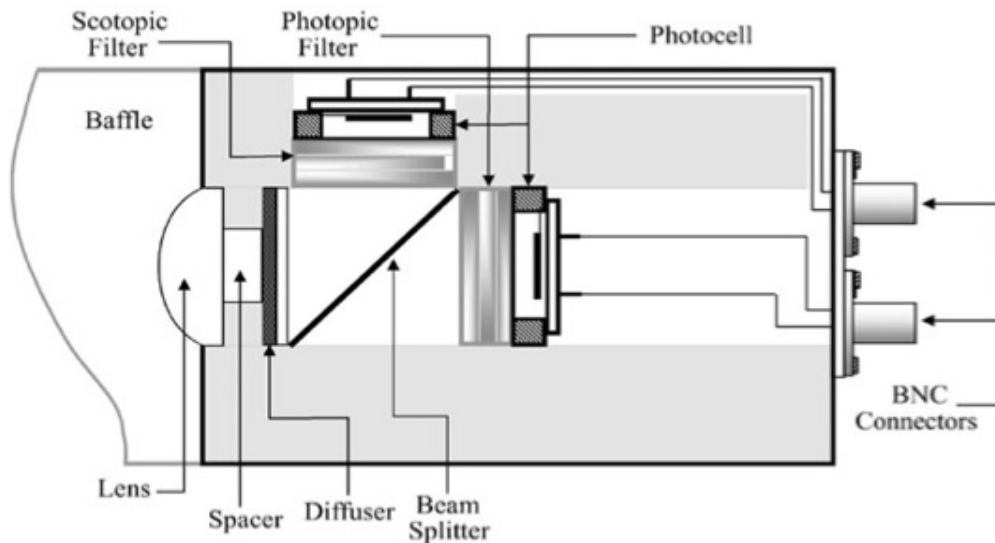

**Figure 5.3 RFD Meter Schematic Diagram (Van Derlofske et al., 2002)**



To simulate the facial cut-off created by a person's face, a cylindrical baffle is used. The aperture of the meter is 5mm in diameter; this is a compromise between a large pupil (8 mm in diameter) that allows for more flux and a small pupil (2 mm in diameter). An optical diffuser evenly fills the silicone photodiodes from all angles. The beam splitter is 70% reflective and 30% transmissive; this means that 70% of the incoming beam of light is reflected upward to the scotopic detector, while 30% of the light beam is transmitted to the photopic detector. Each detector is connected to a silicone-based photodiode detector independent of the other. The higher value of the illuminance directed toward the scotopic detector is based on the higher absorbance of the scotopic filter; therefore, less illumination makes it through creating the low light levels that are typical with scotopic measurements (Van Derlofske et al., 2002).

The way the detector is structured allows for almost simultaneous photopic and scotopic measurements. Processing these readings from the meter after they are taken can allow for additional information to be gained. Through post-processing of the photopic and scotopic values obtained from the RFD meter, a weighted illuminance can be calculated that mimics  $V(10\lambda)$ , the spectral response of the peripheral retina. If the absolute light level is at an appropriate level, the mesopic illuminance can be calculated from post-processing of the meter's readings as well; this is done by adding parts of  $V(10\lambda)$ , the photopic result, and  $V(\lambda')$ , the scotopic result (Van Derlofske et al., 2002).

The RFD meter can be used like a standard illuminance meter (common in industry today) by removing the facial baffle. The facial baffle is what creates the spacial difference between an RFD meter and the standard illuminance meter due to facial shielding. When the baffle is removed, errors can occur when large amounts of illumination at large angles contribute to the reading. To increase accuracy, caution should be exercised to reduce these large angles of illuminance (Van Derlofske et al., 2002).

Also to increase accuracy, the operator should be aware that the lower limit of an RFD meter is 1 lux (lx) for all readings. This should not be much of a hindrance, as 1lx is a very small amount of illumination, 1/10.746 footcandle. The lower limit is set at 1lx due to the noise and interference within the detector becoming a dominant factor in the reading. If readings below 1lx are necessary, special considerations need to be taken. Below 1lx, the meter is more sensitive to ambient settings such as movement and position. To help counteract this sensitivity, a tripod should be used and a stabilization period of 3 to 5 minutes should be maintained before readings

are taken. It is also suggested to take 3 to 5 readings to obtain an average. In the future, it is predicted that RFD meters could be manufactured with a limit even lower than 1lx (Van Derlofske et al., 2002).

## Chapter 6 - Review of Case Studies

Several studies and retrofits have been conducted based on the concept of scotopic vision. This chapter will discuss some of these.

### Warehouse Relamping

One example of the improved efficiency that can be obtained by taking photopic and scotopic vision into consideration is the relamping of a warehouse. In this example, the warehouse originally contained standard high pressure sodium 400 watt lamps with illuminance falling in a lower temperature in the yellow/orange range. The lamp/ballast combination consumed 460 watts per fixture and produced 32,000 photopic lumens, while the scotopic measurement (or what the eye perceives the light as) was found to be 19,840 lumens. These HPS lamps were replaced with Avetria APH160 LEDs, consuming 160 watts of electricity and producing 12,000 photopic lumens and 23,000 scotopic lumens. The illumination produced by these LEDs is a wider spectrum white light, falling close to daylight. When comparing the HPS and LED lamps, it was found that the lamps produce the same photopic lumens/watt; but looking at the scotopic measurements, or human perception, it shows the LEDs consume 61% less energy while producing 18% more perceived luminance than the HPS (“Scotopic”, 2010).



**Figure 6.1 Warehouse Before and After Relamping (“Scotopic”, 2010)**

Taking scotopic vision into consideration has benefitted the warehouse both in perceived illumination by employees and economically by saving the company money.

## **Intel Corporation Retrofit**

A retrofit of a portion of the Intel Corporation facility located in Hillsboro, Oregon, was completed in 1995. They based the retrofit on anticipated scotopic and photopic lumens and ended up pleased with the resulting outcome. The original fixtures contained four 34-watt T12 lamps with energy-saving electromagnetic ballasts; the T12 lamps had a color temperature of 3500K and a CRI of 70. These fixtures were replaced with new fixtures containing two 32-watt T8 lamps with high lumen output electronic ballasts; the new T8 lamps have a color temperature of 5000K and a CRI of 80.

The original lamps provided an average of 65 footcandles (fc) at the workplane, and the new fixtures provide an average of 55fc at the workplane. All measurements were obtained with a typical luminance meter currently used in the lighting industry. Even though the footcandle reading of the new fixtures is lower than the original, workers were saying that the new light levels were too high. To help fix this problem, the high lumen output electronic ballasts were replaced by standard electronic ballasts. This reduced the luminance down to 45fc. Workers said this was better, but still too high.

The retrofit resulted in an energy reduction of 57%. The outcome of the partial retrofit was so well received that it was then applied to all nine buildings on the campus, resulting in an energy savings just over eight million kilowatt hours (Berman, “The Coming”, 2000). This is a product of the role of scotopic vision in the way light is perceived as a direct effect from the higher color temperature creating more rod activation in the human eye.

## **Raleigh, NC, Parking Garage**

A parking garage in Raleigh, North Carolina, replaced their high pressure sodium fixtures emitting a dull orange illumination with a bright white LED fixture. The following page shows a before and after photograph of the garage in Figure 6.2 (“Survey Shows”, n.d.).



Raleigh, NC Parking  
Garage **before** with  
HPS lamps

Raleigh, NC Parking  
Garage **after** with LEDs

**Figure 6.2 Parking Garage Before and After (“Survey Shows”, n.d.)**

Four hundred residents of Raleigh, NC, were surveyed about the parking garage both before the fixtures were changed out and after. The results of the survey showed that 76% more people responded the parking garage felt “very safe” with the LEDs, compared to before with the HPS; 74% of participants rated the parking garage as “very safe” and only 2% did not feel safe with the LED fixtures, while only 42% felt “very safe” with the original HPS fixtures and 13% did not feel safe. The overall frequency of ratings of “excellent” increased 100% after the LEDs were installed, with the overall rating of “poor” decreasing from 8% to 1% after installation. A light-quality rating of “excellent” was reported by 86% of respondents in reference to the post-change out, and the rating of “poor light quality” decreased from 18% to 2%. The rating of cleanliness increased from 58% to 76% as a result of changing the fixtures, this is a 31% increase. This particular survey demonstrates that in addition to the improved perception of light and energy efficiency of bright white LEDs, there is also an improvement in the public’s feeling of safety (“Survey Shows”, n.d.).

### **IES Study**

At the 1992 Illuminating Engineering Society meeting in San Diego, CA, over 100 members were asked to choose which of two rooms appeared brighter. The rooms were the same, the only difference being the light source; one room had a more scotopically enhanced light source than the other. This study resulted in all but two participants choosing the room with the scotopically enhanced light as appearing brighter, even though it was measured by a

conventional luminance meter as being 30% lower in illuminance (Berman, “The Coming”, 2000).

### Lamp Type Comparisons

Various types of lamps and individual lamps of each type vary in illumination. The following sections will be comparing some of the more common lamps used in industry today. The analyses being completed on these lamps include direct comparisons of photopic and scotopic lumens; photopic, scotopic, and mesopic luminous efficacies; S/P ratios; lumens per watt; pupil lumens per watt; and efficiencies.

#### *Narrowband Fluorescent v. Cool-White & Warm White Fluorescent*

One comparison completed by S. M. Berman looks at a narrowband 5000K 40W fluorescent lamp, a cool white 40W fluorescent lamp, and a warm-white 40W fluorescent. Results show that the 5000K fluorescent uses 24% less energy than the cool-white lamp and 44% less energy than the warm-white lamp based on the pupil lumens per watt, also known as the visual effectiveness per watt and the relative power. This can be seen from the following table, Table 6.1. It can also be deduced from the table that as the ratio of scotopic lumens to photopic lumens increases, so does lamp efficiency (Berman, “Energy”, 1992).

Lamp	Photopic lumens	Scotopic lumens	Effective pupil lumens [P(S/P).78]	Relative Power, level for equal pupil size	Pupil lumen, Per watt
Warm-white fluorescent (WW)	<b>3200</b>	<b>3100</b>	<b>3125</b>	<b>136</b>	<b>78</b>
Cool-white fluorescent (CW)	<b>3150</b>	<b>4630</b>	<b>4254</b>	<b>100</b>	<b>106</b>
Narrow-band phosphor fluorescent (5000 K) [NB(5000)]	<b>3300</b>	<b>6468</b>	<b>5578</b>	<b>76</b>	<b>139</b>

**Table 6.1 Fluorescent Comparison (Berman, “Energy”, 1992)**

### *Incandescent v. High Pressure Sodium*

Another comparison was completed by S. M. Berman comparing a 125W Incandescent lamp to a 35W High Pressure Sodium lamp. Both lamps provide the same photopic lumens of 2250 lumens. If looking at the photopic lumens and input wattage, the HPS appears to easily be the more efficient choice. But when looking at pupil lumens per watt for each lamp, with a small pupil being the goal, the results show a very small advantage in efficiency for the HPS; this difference is so small as to be pretty much negligible.

When looking at Table 6.2 that follows, it can be seen that the pupil lumens per watt are about the same for the two lamps. Taking this into consideration, the two lamps operate at relatively the same power level to create about the same visual effectiveness. These findings enforce the concept that to find the true efficiency, more than just the photopic lumens must be considered (Berman, “Energy”, 1992).

Lamp (2250 lumens)	Lumens per watt	Ratio S/P	Relative Power level for equal pupil size	Pupil lumens per watt
125 W incandescent	<b>18</b>	<b>1.4</b>	<b>100</b>	<b>23.4</b>
35 Watt HPS	<b>50</b>	<b>0.4</b>	<b>96</b>	<b>24.5</b>

\*(10 W for ballast is included)

**Table 6.2 Comparison of Incandescent and High Pressure Sodium Lamps (Berman, “The Coming”, 2000)**

### *High Pressure Sodium v. Cool White Fluorescent*

The accuracy of reading among participants in illumination provided by high pressure sodium (HPS) lamps is compared to the accuracy of reading in illumination provided by cool white (CW) fluorescent lamps, with both lamps having a 50 footcandle (fc) reading measured using a conventional luminance meter; it was found that the HPS has a lower S/P ratio than the CW fluorescent. This comparison was originally conducted by H. A. Piper and was recently investigated by S. M. Berman. The lower S/P ratio of the HPS results in a larger pupil size which in turn results in a smaller depth of field and poorer performance. In addition, the HPS has a blue deficiency in its light output; therefore, more of its spectral energy is out of focus compared to the CW fluorescent (Berman, “Energy”, 1992).

### *Fluorescent Color Temperature*

Two 32-watt T8 fluorescent lamps with CRIs of 85 and differing color temperatures were compared; this comparison was carried out by Sam Berman. Lamp A has a color temperature of 3500K and 2950 initial photopic lumens; lamp B has a color temperature of 5000K and 2800 initial photopic lumens. Lamp choice is generally based on luminous efficacy. Using this basis, lamp A would be the best choice, but to incorporate scotopic and photopic vision, the lamp choice should be based on visually effective lumens. To calculate visually effective lumens, the photopic lumens need to be multiplied by  $(S/P)^{0.78}$ . Applying this, lamp A has 3835 visually effective lumens, while lamp B has 4619 visually effective lumens. This would actually make lamp B the better choice, as it has 20% more visually effective lumens per watt than lamp A (Berman, “The Coming”, 2000).

	Color Temperature	Initial Photopic lumens	Visually Effective lumens
Lamp A	3500K	2950	3835
Lamp B	5000K	2800	4619

**Table 6.3 32W T8 Fluorescent Lamp Comparison**

### *LEDs*

Different efficacies among LEDs should be considered when selecting the desired lamp for the given application. Three different LEDs, with differing color temperatures, were compared by Peng, Yi-feng, Qi-feng, Rooymans, and Chun-yu. All three lamps are in the Cree XLamp XR-E series. Lamp A is the cool white lamp with a color temperature of 8000K, lamp B is the natural white lamp with a color temperature of 4500K, and lamp C is the warm white lamp with a color temperature of 3500K. The chart on the following page summarizes the findings of this study (Peng et al., 2009).



LED type	Photopic luminous efficacy (lm/w)	Scotopic luminous efficacy (lm/w)	Mesopic luminous efficacy (lm/w)	S/P
A (cool white)	93.3	200.5	156.0	2.01
B (natural white)	92.2	142.9	122.7	1.52
C (warm White)	84.2	112.2	101.5	1.39

**Table 6.4 LED Comparison (Peng et al., 2009)**

When comparing the mesopic luminous efficacy of one LED to the photopic luminance efficacy of that same LED, the result is an increase in efficacy of 67.2% for lamp A, 33.1% for lamp B, and 20.5% for lamp C. This demonstrates the difference and potential benefits achievable by distinguishing between how luminance is currently measured and how luminance is perceived by the human eye. From the table above, Table 6.4, it can also be seen that the luminous efficacy varies between LEDs. For example, LED A is 53% more efficient than LED C. These findings back-up the fact that the eye perceives light in the bluish coloring as brighter than light in the yellowish region (Peng et al., 2009).

### **Suggestions**

Retrofitting lamps and in some cases fixtures, can be very beneficial, as has been the case with the previous surveys and studies discussed. Patrons see many improvements in the lighting of the space and are very happy with the changes. In addition, it is a great benefit to the owners by increasing energy efficiency with short pay-back periods. The benefits seen with retrofitting are also realized by new designs as well, with the patron's satisfaction and energy efficiency both being high.

When choosing a light source, it is important to take into consideration all aspects of a light source, as has been demonstrated through these studies. A designer cannot look at only one or two aspects or characteristics of a lamp; to truly select the best lamp to fit the application and use of the space, the various attributes of the lamps must be investigated to achieve the best option possible and to see the whole picture. Photopic and scotopic lumens; photopic, scotopic, and mesopic luminous efficacies; S/P ratios; lumens per watt; pupil lumens per watt; and efficiencies must all be compared to choose the best lamp for the application of the fixture. Occupancy, aesthetics, controllability, maintenance, and lamp life should also be considered.

## **Chapter 7 - Manhattan, KS Case Study**

The city of Manhattan, Kansas, is changing out their downtown lighting on Poyntz Avenue. The street is currently illuminated by high pressure sodium lamps (HPS) and will be replaced with LED fixtures. At the time the survey was conducted, one pole had been retrofitted with the LED fixture as a tester. A survey was composed to compare the new fixture to the existing fixture.

There were two sections of the survey with duplicating questions to ensure valid responses. The first section asked if those surveyed preferred the new LED fixture or the existing high pressure sodium fixture. If the participant responded by saying the light sources were equal, their responses were thrown out when totaling that question's results. The second section consisted of rating each lamp type on a scale from one to five in various categories, with five being the most favorable. A final section was for comments.

The survey was conducted on five evenings after dark for a time period of about two hours each evening. The dates of the surveys were May 2, 4, & 5, 2010, from 9:00pm to 10:40pm and September 14 & 15, 2010, from 8:15pm to 10:00pm. Surveys were answered anonymously after being handed out to individuals and then returned for data analysis after completion. 89 individuals participated in the survey, with a large majority being college-aged students; the results showed a definitive preference towards the LED fixture.

A copy of the survey is found in Appendix A, with the results being found in Appendix B and C. Survey results were tabulated for males, females, and combined. Results were separated to see if preference differed between genders, however, this was not the case as results among the groups were very similar throughout the survey. Graphical representations of these results can be found in the body of this chapter. Figure 7.2, found on page 30, depicts graphically the results of the survey in percentage form. Figure 7.3, on page 32, is the graphical representation of rating averages. These graphs aim to help show the differences among the survey results.

### **Background**

Before the results of the survey are discussed, a background of the retrofit will be given. The existing light fixtures are an acorn-style fixture in the Sternberg Old Town Series. There are

poles along both sides of Poyntz Avenue and on each of these poles are two 150W high pressure sodium lamps mounted on arms. The replacement fixture uses the existing poles with a new lamp and housing that matches the existing one. The mounting height for both fixtures is 11 feet. Each pole will be retrofitted with two 51W LED banks housed in acorn-style housing with a full cutoff roof to prevent uplight. The purpose of the full cutoff roof is to prevent light pollution up into the sky. Illumination is not needed above the fixture as this is not where the patrons will be. Having the full cutoff roof also allows for the area to be more natural, allowing for viewing of the night sky and stars. The full cutoff roof however, does not illuminate the upper facades of buildings very well. The following photographs show these two fixtures; their cut-sheets can be found in Appendix G & H.



Replacement LED

Existing HPS

**Figure 7.1 Light Fixtures on Poyntz Avenue; Manhattan, KS**

### **Overall Results**

The results among the groups (male, female, and overall) were very similar, and were as follows for the overall preference between the LED and the high pressure sodium (HPS) lamps: 83% of males, 88% of females, and 85% overall preferred the LED over the HPS. The participants were asked again about their overall preference by rating the lamps. The results again showed a preference for the LED, with 98% of males, 94% of females, and 97% overall

giving the lamp a rating of four or five. The rating of the HPS was fairly even: 34% gave it a one or two, 42% gave the HPS a three, and 24% gave the HPS a four or five. The LED lamp had higher percentages and ratings than the high pressure sodium in all questions asked; one participant had the response of “love the LEDs, glad for the change”, and one stated that they felt the change would “brighten up” the downtown area.

### **Results on Illumination**

When asked which luminance source is brighter/puts out more light, 87% of males, 94% of females, and 90% overall felt the LED fixture was brighter and put out more light. This was reinforced later on in the survey when the participants were asked to give the luminaire sources a rating of one to five, with five being the best on illumination, the amount of light distributed by the sources. 89% of males gave the LED a rating of a four or five, while 97% of women and 92% of the overall participants rated the LED a four or five as well for illumination. The ratings of the high pressure sodium were more evenly distributed for illumination. The majority of the participants gave the HPS a rating of three; the percentages were 47% of males, 59% of females, and 52% overall. The HPS’s ratings for 1 & 2 and 4 & 5 were both around 20% for all three participant categories. One participant commented that LEDs provided a brighter, cleaner light.

Another question on the survey dealing with illumination asked about the uniformity and evenness of the light distribution. The LED received ratings of 4 & 5 by a very high margin, being in the upper ninety percent for all groups of participants. The results for the HPS were not as definitive, with 4s & 5s given by around 40% of participants and also 3s receiving around 40%.

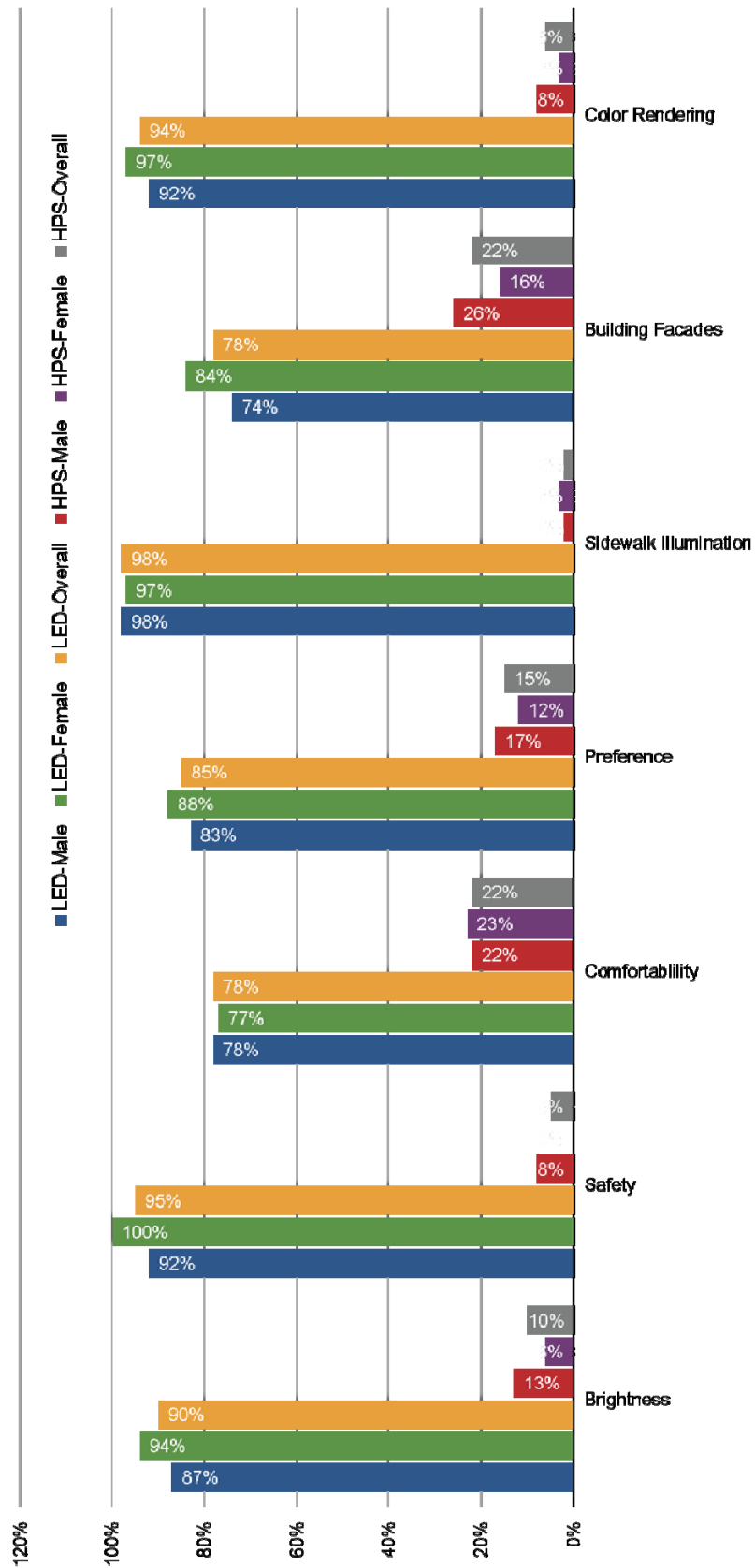

Figure 7.2 Percentage Results of Participant Preference, Poyntz Avenue

## **Distinguishability and Color Rendering**

In the downtown Poyntz Avenue application of these fixtures and in most applications, there are aspects of lighting that should take a high priority in the selection process, in addition to illumination as previously discussed. These aspects are: being able to see and distinguish objects, ease of reading, and color rendering. When rating the ability to see and distinguish objects in the two lamp types, the LED had a higher rating. The average rating for the LED was 4.72, while the average rating of the HPS was 3.08. The ease of reading was higher for the LED than the HPS by 1.5 points, with the average rating for the LED being 4.72 and the average rating of the HPS being 3.21. Color rendering was much higher for the LED than for the HPS: the LED received a rating of 4.56, while the HPS received an average rating of 2.36.

There were several comments about the color rendering of the lamp types and the ability to distinguish objects. One participant had this to say, “I like to be able to distinguish objects and their color. The LED is much better for giving true color. Both provide enough light, but the HPS doesn’t allow for me to distinguish objects very well.”

## **Safety and Feeling of Comfort**

Feeling safe and comfortable in your surroundings is important to most people, especially at night. Safeness and comfortability, being at ease and not feeling tension or stress, were investigated in this survey to see if any correlations exist between how safe and comfortable a person feels and the type of illumination they are in.

The feeling of safety in the two lamps types was investigated. The LED again was shown an overwhelming preference. 92% of males, 100% of females, and 95% overall felt safer in the LED than in the HPS. This was again reinforced later in the survey with rating of the two lamp types. The LED received a four or five by all but a few of the participants. The rating for the HPS was more spread out. 1s and 2s were given by about 20% of participants, while about 30% of participants gave the HPS a 3 rating, and around 40% rated it at four or five.

A feeling of comfort within the illumination was examined in this survey as well. In the comfort segment of the survey, the LED again received a large number of high ratings. 98% of males, 85% of females, and 93% overall gave a four or five to the LED. The HPS received a four or five by around 50% of participants, with around 25% giving it a 3, and about 20% giving a

rating of one or two. 78% of participants said they felt more comfortable in the LED than in the HPS.

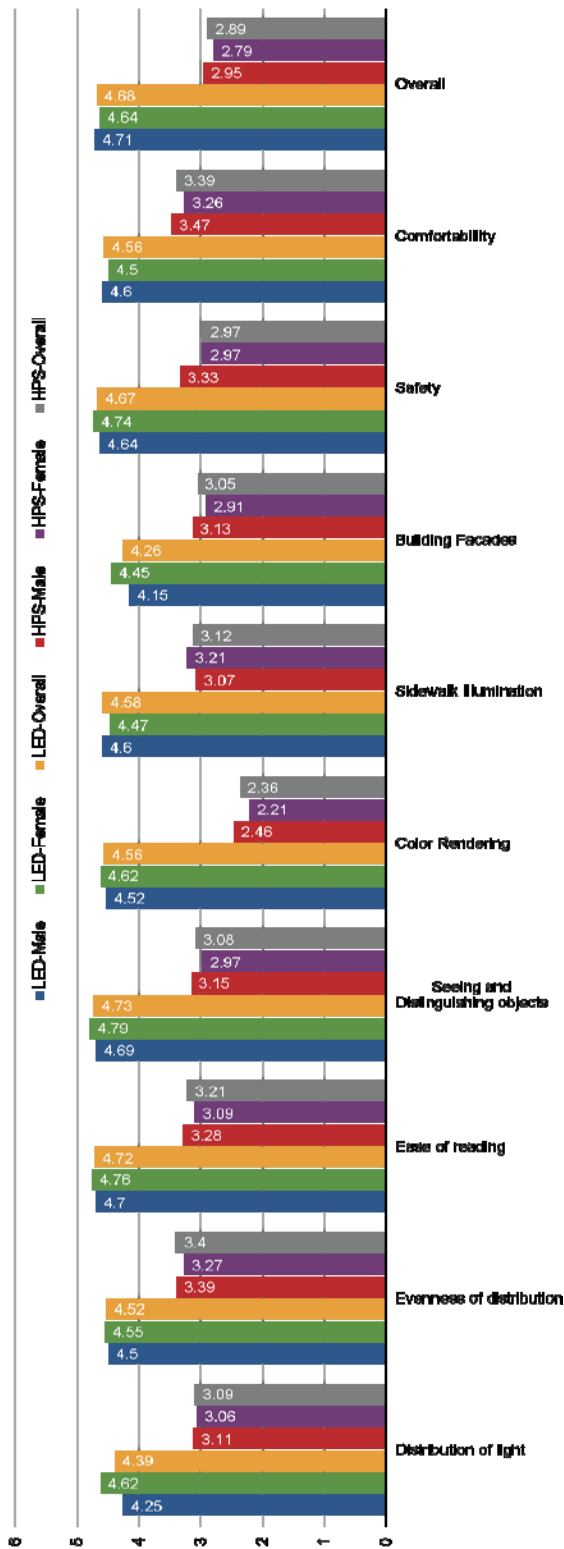

Figure 7.3 Average Results of Ratings, Poyntz Avenue

## **Facades and Signage**

Poyntz Avenue contains retail spaces and restaurants. With this being the case, the illumination of building facades should be considered, as well as color rendering and signage.

Many of the building facades are made of limestone; this is unique and a trademark of Manhattan, Kansas, and should therefore be enhanced by the lighting, if possible. 74% of males, 84% of females, and 78% overall felt that the LED provided better illumination on the facades of the buildings. This was verified with a rating of the lamps. 85% gave the LED a four or five while the HPS was evenly distributed with 31% giving a four or five, 37% giving it a three, and 31% rating it at a one or two.

Facades can also be affected by color rendering, as can signs. A very large majority of the participants stated that LEDs provide better color rendering on the facades of the buildings as well as better color rendering for signage; 92% of males said this, while 97% of females felt this way, and overall there was a 94% preference towards the LED.

When asked about the true color of the signage on the buildings and objects, the preference for the LED fixture was again very great. 94% rated the LED a four or five for having great color for objects and building signage, while more people rated the HPS at a one or two: 59% rated it at this level and 27% gave the HPS a three and the remaining 14% rated it at a four or five.

Even though the preference was for the LED, there were a few comments given about the HPSs. One participant commented, “I like the HPS yellowness on the limestone facades of the buildings. The LEDs are a little too harsh.” On the following page, Figure 7.4, is a picture that depicts the differing color temperatures of the HPS, on the left, and the LED, on the right.





**Figure 7.4 Poyntz Avenue**

### **Sidewalk Illumination Results**

Because of the number of businesses on Poyntz Ave., there is a fair amount of pedestrian traffic. This means that the illumination of the sidewalk is an important aspect to consider. 98% of participants felt that the LED did a better job of illuminating the sidewalk than the HPS did; this means that 2% felt the HPS illuminated the sidewalk better. These results were again verified by having participants rate the light fixtures on their ability to illuminate the sidewalk. 94% gave the LED a five or four, 6% gave the LED a three, and no one gave it a one or two. As has been the trend, the rating for the HPS was more spread out: 30% gave the HPS a four or five, 46% gave it a three, and 24% gave the HPS a one or two.

### **Participant Comments**

There were a few comments that related different aspects of the lamp types and tied them together. Color rendering affected comfort for one participant while it influenced the feeling of safety for another. The comments were as follows: “Feeling of comfort is tied directly to colors shown in light. LED shows more color, therefore there are more things to observe; which increases comfort level”; “LED provides a much more comfortable and well lit space, as well as a more true to color lighting”; and “LED provides light that gives better color and makes for a safer feeling.”

Other comments included: “I like the change to LED; to me it is much cleaner and a softer feeling”; “Definitely prefer the LED because of its color rendering and feeling of visual brightness in comparison to the HPS. It feels ‘sharper.’ It does change the limestone to more of a white than tan, but I prefer this”; “The LED provides a cleaner and crisper light, and is more visually appealing. The LED seemed more consistent in color, whereas the HPS seemed to have varying color output among the various fixtures”; “I am very much an aesthetics type of person, so I really enjoy the HPS; but at the same time, it’s hard to see in it. I don’t like the ‘feel’ of the LED; it makes the streets too sterile looking. But, being a girl I like the ‘brighter’ light”; and “It’s a lot easier to distinguish objects in the dark (even from far away) with the LED lighting. I would feel safer with the LED lights on Poyntz and would be more apt to spend time downtown during night. Also, the LED lights help bring out the texture of the limestone facades to make the buildings more aesthetically pleasing.”

### **Survey Conclusions**

The survey was a success and resulted in concrete evidence for a definitive preference towards the LED lamp source. Not only does the public seem to like the LED better, but LED also has added benefits for the city of Manhattan. In addition to the possibility of increased activity for the businesses on Poyntz resulting from the retrofitting of the lamps, the city will see direct economical benefits from reduced energy consumption and reduced maintenance costs.

Footcandle readings were taken for the new and existing light fixtures. These readings were obtained when it was dark and in a circular pattern at increasing radii. A circular grid was created around each fixture, with eight measurements taken every 45 degrees, unless buildings interfered. The first circle had a 2-foot radius; four more concentric circles were created on the grid with 5’, 10’, 20’, and 30’ radii. It was found that the average footcandle reading for the existing HPS was 2.02 with the levels peaking about ten feet from the base, as to form a donut-type illumination pattern. The average footcandle reading for the LED was 2.23 with the peak readings at the base and decreasing outward. These values were found using a typical luminance meter found in industry today. The following tables, Table 7.1 and Table 7.2, show the obtained readings. The location of these readings can be observed in Appendix D and the values at each location can be observed in Appendix E & F.

Existing HPS Fixture					
	2' Radius	5' Radius	10' Radius	20' Radius	30' Radius
	1.92	2.38	2.56	1.50	0.99
	1.88	2.68	2.76	1.64	1.01
	1.69	2.06	2.35	1.42	0.89
	1.70	3.00	3.22	1.71	1.02
	1.75	2.99	3.68	2.00	0.81
	1.96	2.49	4.29		
	2.10	1.84	2.97		
	2.11	2.17	3.62		
Average	1.89	2.45	3.18	1.65	0.94
Total average fc for all circles			2.02		

**Table 7.1 HPS Illuminance Measurements (fc)**

Proposed LED Fixture					
	2' Radius	5' Radius	10' Radius	20' Radius	30' Radius
	3.34	2.99	2.82	1.62	1.07
	3.04	3.40	2.38	1.45	0.98
	2.94	3.05	1.93	1.08	0.75
	3.23	2.97	2.33	1.42	1.01
	3.49	3.08	2.39	1.53	
	3.65	2.89	2.65	1.90	
	3.19	2.31	2.71		
		2.48	2.95		
Average	3.27	2.90	2.52	1.50	0.95
Total average fc for all circles			2.23		

**Table 7.2 LED Illuminance Measurements (fc)**

Taking into consideration the scotopic aspect of the output of the lamps, the HPS appears to the eye to have a total average of 1.39 footcandles, using the equation  $P(S/P)^{0.78}$  and an S/P ratio of 0.62, while the LED has a total average of 3.83fc using the same equation and an S/P ratio of 2.0. This higher rating is reinforced by many comments stating that the LED appears brighter.

A big advantage of replacing the HPS fixtures for the city is a reduction in the cost of illuminating Poyntz Avenue. One pole with the old fixtures consumes a little over 300W, whereas the new LED fixtures consume 102W per pole. This equates to a savings of about 66% on the electricity it takes to power these light fixtures, as can be seen from the following table, Table 7.3. This does not include the savings on maintenance resulting from the fact that lamp replacement is needed much less often for LEDs than for HPS lamps, as the lamp life of an LED is 25,000 to 50,000 hours and the lamp life of an HPS is 12,000 to 24,000 hours. Looking at an average of lamp life hours for both lamp types, the LED will need to be relamped 19,500 hours after the HPS is relamped.

ENERGY CONSUMPTION PER POLE					
	WATTS	HRS/YR ON	Kwh	\$/kwh	YEARLY COST
LED	102	4380	446.76	\$0.07	\$31.27
EXISTING	300	4380	1314.0	\$0.07	\$91.98
SAVINGS PER FIXTURE FROM LED					
\$60.71	=	66%			

**Table 7.3 Energy Consumption**

Switching to LEDs appears to be an overall positive move for the city of Manhattan, Kansas, both in regards to patron satisfaction and from an economic standpoint. The individuals surveyed favored the LED over the HPS in all categories and chose the LED as the overall preferred lamp type. The public felt the LED provides: better illumination in general, on the sidewalk, and on the building facades; better color rendering; an increased feeling of safety; an improved and more even distribution of light; an enhanced ability to see and distinguish objects; and a setting more conducive to reading. The improvements gained from the change-out of lamps on Poyntz Avenue in downtown Manhattan, KS, could translate into an increase in customer traffic for businesses and will save the city around \$4,150.00 per year on operating cost alone. More money will also be saved resulting from the decreased amount of lamp maintenance required. The money saved by Manhattan, KS, can be put into additional improvements to the city. It appears this city project will be a very worthwhile investment.

## **Further Investigations**

The survey did not analyze differences among ages; this would be an interesting aspect to investigate, as the eye changes as people age. If the survey were to be duplicated, a question asking the participant's age would be included in the questionnaire to see if correlations could be drawn from the data.

## **Chapter 8 - Relationships Among Case Studies**

The results found during the survey conducted on Poyntz Avenue in Manhattan, KS, backed up the results found in other published surveys dealing with LEDs and photopic and scotopic vision. When looking at the different surveys and studies conducted, it is a trend that the outcome of scotopic vision and LEDs carry with them many advantages as well as a higher preference among patrons.

Safety has been an aspect of LEDs and scotopic vision that has been investigated through several different studies. The results of the Manhattan, Kansas, Poyntz Avenue survey and the Raleigh, North Carolina, parking garage survey both reinforced the idea that people felt safer in the illumination of scotopically enhanced lamps.

Many studies have come to the conclusion that scotopically enhanced lamps appear to be brighter and to provide more illumination than lamps with less scotopic enhancement. The survey conducted on Poyntz Avenue in Manhattan, Kansas; the warehouse retrofit; the Intel Corporation retrofit; the Raleigh, North Carolina, parking garage; and the 1992 IES study all reinforced this concept.

Along with the perception of increased illumination, comes a decrease in energy consumption. All the previously discussed studies resulted in economic benefits. As a result of using scotopically enhanced illuminance sources, more perceived lumens per watt are produced. This means there is less electrical input required for the same, and even more, luminaire output when scotopic vision is incorporated. This is a huge benefit for companies, municipalities, and owners.

## Chapter 9 - Suggested Industry Improvements

It would be a huge benefit, to the lighting industry and clients, to create more cohesion between photometry and color, and to create a more accurate way to measure luminance by including scotopic performance into calculations; this would give a measured luminance level closer to the way the eye perceives the light (“Scotopic”, 2010). Also, the difference between  $V(\lambda)$  and  $VM(\lambda)$  is more noticeable for LED lights. These light sources are becoming more prevalent in industry, so the drive to change the system should increase (Schanda et al., 2002).

There are many benefits that can be realized from the incorporation of scotopic vision; the time and effort that would be required to make this change would be worth it, based on the advantages discussed previously in this paper. Individuals seem to prefer scotopically enhanced lamp types, plus there is a direct economic benefit associated with the incorporation of scotopic vision into the design.

One way to improve the industry would be to use light meters that incorporate the scotopic vision into the meter output reading. This would be an easy way to enhance the design of the lighting system, but this would require a costly investment for individuals. Until the cost of these meters comes down, a solution that would have definite improvements on the lighting industry would be to use the S/P ratio of lamps. This will allow readings from current light meters to be converted to include the scotopic enhancements of the lamps. Doing this will add one simple calculation to the process, a very small amount of additional work to introduce many positives into the design. So until new meters come down to a reasonable price, the best option is to use the S/P ratio in calculations.

## Chapter 10 - Conclusion

In nearly every industry, technology advances, and with these advances comes necessary changes in the way design is completed. To take full advantage of the new lighting technology, more aspects of lighting must be explored. It's time to incorporate scotopic vision into the concepts of lighting design that have been used during the past several decades. This can allow for so many more opportunities in the lighting world, to really improve the industry and make clients and the public much more satisfied.

Rods and cones play an important role in human vision and light perception, and have a direct effect on photopic, scotopic, and mesopic vision. The industry does not currently measure luminance and design lighting to match how the human eye perceives light. It is important that the output of lighting more closely align to how illumination is received and processed by the eye.

A few of the benefits that can be realized from the incorporation of scotopic vision into the lighting industry are: economic savings; overall preference by patrons (as has been supported by several studies); and increased visual performance, clarity, brightness, and feeling of safety. This can all be achieved by choosing scotopically enhanced lamps and incorporating S/P ratios into calculations or using an RFD meter.

Incorporating S/P ratios and utilizing RFD meters are small changes that could really change the lighting industry for the better, by greatly increasing user satisfaction, reducing cost of operation, and saving energy.

This paper has discussed the human eye, scotopic vision, and how the eye perceives light. Case studies were also compared to fully inform readers of real-life applications of scotopic vision incorporation. As can be seen from the preceding text, there are many advantages associated with the assimilation of scotopic vision, with no sizeable disadvantages: it is time for the lighting industry to change and advance as industry technology does.



## Bibliography

- Berman, S. (1992). Tuning the Light Spectrum to Improve Energy Efficiency. *IAEEL Newsletter*, 2.
- Berman, S. (2000). The Coming Revolution in Lighting Practice. *Energy Users News*, 25(10), 23-25.
- Berman, S.M. (1992). Energy Efficiency Consequences of Scotopic Sensitivity. *Journal of the Illuminating Engineering Society*, 21(1), 3-14.
- Erdman, D. (n.d.). Photopic and Scotopic – The Eyes Have It Psychological Inquiry. Retrieved from February 19, 2010, [http://www.gelighting.com/na/business\\_lighting/education\\_resources/literature\\_library/wHITE\\_papers/download/photopic\\_scotopic\\_lb.pdf](http://www.gelighting.com/na/business_lighting/education_resources/literature_library/wHITE_papers/download/photopic_scotopic_lb.pdf)
- Eye Spectral and Intensity Response. (n.d.). Retrieved February 19, 2010, from [http://www.telescope-optics.net/eye\\_spectral\\_response.htm](http://www.telescope-optics.net/eye_spectral_response.htm)
- Green, M. (2009). Night Vision. Retrieved February 19, 2010, from <http://visualexpert.com/Resources/nightvision.html>
- Josefowicz, J., & Ha, D. (2008). Human Eye Response to LED Light: Scotopic Versus Photopic Light and Vision. *LED Roadway Lighting Ltd.*, November, 1-10.
- Ning, Z., Weiming, D., Jiabin, W., & Jean-Claude, P. (2009). Simulating Human Visual Perception in Nighttime Illumination. *Tsinghua Science and Technology*, 14(1), 133-138.
- Peng, J., Yi-feng, W., Qi-feng, Z., Rooymans, J., & Chun-yu, Y. (2009). Luminous Efficacy of White LED in the Mesopic Vision State. *Optoelectronics Letters*, 5(4), 265-267.
- Rea, MS., & Bullough, JD. (2007). Making the Move to a Unified System of Photometry. *Lighting Research and Technology*, 39(4), 393-408.
- Rea, MS., Bullough, JD., Freyssinier-Nova, JP., & Bierman, A. (2004). A Proposed Unified System of Photometry. *Lighting Research and Technology*, 36(2), 85-111.
- Schanda, J. (1997). CIE Colorimetry and Colour Displays. *The Fourth Color Imaging Conference: Color Science, Systems and Applications*, 230-233.
- Schanda, J., Morren, L., Rea, M., Rositani, L., & Walraven, P. (2002). Does Lighting Need More Photopic Luminous Efficiency Functions?. *International Journal of Lighting research and Technology*, 34(1), 69-78.

- Scotopic vs. Photopic Light Measurements. (2010). *Avetria*. Retrieved February 19, 2010, from <http://www.avetria.com/led/pgs/ledbasics-photopic-scotopic.html>.
- Some Issues in Low Light Level Vision. (1996). Retrieved February 19, 2010, from <http://data.nextrionet.com/site/idsa/is136.pdf>.
- Survey Shows Public Feels Safer in City Spaces Lit by LEDs. (n.d.). Retrieved February 19, 2010, from [http://www.cree.com/press/press\\_detail.asp?i=1175179209372](http://www.cree.com/press/press_detail.asp?i=1175179209372).
- Turlej, Z. (2000). Tuning the Color of an Artificial Lighting to Improve Energy Efficiency. *Optical Sensing for Public Safety, Health, and Security*, 4535, 145-153.
- Van Derlofske, J., Bierman, A., Rea, M., Ramanath, J., & Bullough, J. (2002). Design and optimization of a Retinal Flux Density Meter. *Measurement science and Technology*, 13, 821-828.
- Visually Effective Light. (2010). Retrieved February 19, 2010, from <http://www.globalinductionlighting.com/visuallyeffectivelighting.php?osCsid=d859be17e3de288a4b5f8574bef52487>.
- Yaguchi, H. (2006). Mesopic Color Reproduction. *ICO20: Illumination, Radiation, and Color Technologies*, 6033, 1-3.

## References

- Berman, S M., Jewett, D L., Phil, D., Fein, G., Saika, G., & Ashford, F. (1990). Photopic Luminance does not Always Predict Perceived Room Brightness. *Lighting Research and Technology*, 22(1), 37-41.
- Photometry Light Measurement. (n.d.). Retrieved February 19, 2010, from [http://www.intl-lighttech.com/applications/light-measurement-apps/photometry/index\\_htm](http://www.intl-lighttech.com/applications/light-measurement-apps/photometry/index_htm)
- Shin, J., Matsuki, N., Yaguchi, H., & Shioiri, S. (2003). Color Appearance in Mesopic Vision and its Modeling. *IS&T/SID Eleventh Color Imaging Conference*, 11 165-169.

## Appendix A - Poyntz Avenue Survey; Manhattan, KS

Are you:      Male    or      Female

Which light source is brighter/puts out more light?

Which light source do you feel safer in?

Which light source do you feel more comfortable and at ease in?

Which light source do you prefer?

Which light source provides better light on the sidewalk?

Which light source provides better light on the building facades?

Which light source creates more accurate coloring of the building facades and signage?

Please rate each light source on a scale from 1 to 5 (with 5 being the best) in the following categories.

Illumination, the amount of light distributed by the light source:

LED    1      2      3      4      5

HID    1      2      3      4      5

Uniformity/evenness of light distribution:

LED    1      2      3      4      5

HID    1      2      3      4      5

Ease of reading:

LED    1      2      3      4      5

HID    1      2      3      4      5

Ease of seeing and distinguishing objects:

LED    1      2      3      4      5

HID    1      2      3      4      5

Color, how the light source affects the true color of objects and building signage:

LED    1      2      3      4      5

HID    1      2      3      4      5

Lighting of the sidewalk:

LED	1	2	3	4	5
HID	1	2	3	4	5

Lighting of the building facade:

LED	1	2	3	4	5
HID	1	2	3	4	5

Feeling of safeness:

LED	1	2	3	4	5
HID	1	2	3	4	5

Feeling of comfortability/at ease (more comfortable=5):

LED	1	2	3	4	5
HID	1	2	3	4	5

Overall Rating/preference:

LED	1	2	3	4	5
HID	1	2	3	4	5

Can you read this sentence better in the LED or HID lighting?

Comments:

## Appendix B - Survey Results - Quantities

Are you: Male(55) or Female(34) Total(89)

\*If the response was "same" or "both" for any of the following questions, it was not counted in the results.

Which light source is brighter/puts out more light?

LED (48)(32)(80) HPS (7)(2)(9)

Which light source do you feel safer in?

LED (48)(31)(79) HPS (4)(0)(4)

Which light source do you feel more comfortable and at ease in?

LED (40)(23)(63) HPS (11)(7)(18)

Which light source do you prefer?

LED (45)(29)(74) HPS (9)(4)(13)

Which light source provides better light on the sidewalk?

LED (53)(32)(85) HPS (1)(1)(2)

Which light source provides better light on the building facades?

LED (36)(27)(63) HPS (13)(5)(18)

Which light source creates more accurate coloring of the building facades and signage?

LED (48)(32)(80) HPS (4)(1)(5)

One male overall preferred HID

Please rate each light source on a scale from 1 to 5 (with 5 being the best) in the following categories.

average

Illumination, the amount of light distributed by the light source: (53)(34)(87)

4.39 LED 1 (1)(0)(1) 2 (1)(0)(1) 3 (4)(1)(5) 4 (25)(11)(36) 5 (22)(22)(44)

3.09 HID 1 (0)(1)(1) 2 (13)(5)(18) 3 (25)(20)(45) 4 (11)(7)(18) 5 (4)(1)(5)

Uniformity/evenness of light distribution: (54)(33)(87)

4.52 LED 1 (0)(0)(0) 2 (1)(1)(2) 3 (2)(1)(3) 4 (20)(10)(30) 5 (31)(21)(52)

3.40 HID 1 (0)(2)(2) 2 (11)(5)(16) 3 (17)(16)(33) 4 (20)(7)(27) 5 (6)(4)(10)

Ease of reading: (53)(34)(87)

4.72 LED 1 (0)(0)(0) 2 (0)(1)(1) 3 (3)(0)(3) 4 (10)(5)(15) 5 (40)(28)(68)

3.21 HID 1 (1)(1)(2) 2 (7)(8)(15) 3 (24)(12)(36) 4 (18)(13)(31) 5 (3)(0)(3)

Ease of seeing and distinguishing objects: (55)(34)(89)

4.73 LED 1 (0)(0)(0) 2 (0)(1)(1) 3 (1)(0)(1) 4 (15)(4)(19) 5 (39)(29)(68)

3.08 HID 1 (2)(0)(2) 2 (11)(10)(21) 3 (25)(16)(41) 4 (11)(7)(18) 5 (6)(1)(7)

Color:how the light source affects the true color of objects and building signage: (54)(34)(88)

4.56 LED 1 (1)(0)(1) 2 (0)(0)(0) 3 (4)(0)(4) 4 (14)(13)(27) 5 (35)(21)(56)

2.36 HID 1 (12)(8)(20) 2 (19)(13)(32) 3 (13)(11)(24) 4 (6)(2)(8) 5 (4)(0)(4)

Lighting of the sidewalk: (55)(34)(89)

4.58 LED 1 (0)(0)(0) 2 (0)(0)(0) 3 (2)(3)(5) 4 (18)(9)(27) 5 (35)(22)(57)  
 3.12 HID 1 (2)(1)(3) 2 (12)(6)(18) 3 (26)(15)(41) 4 (10)(9)(19) 5 (5)(3)(8)

Lighting of the building facade: (54)(33)(87)

4.26 LED 1 (0)(0)(0) 2 (2)(0)(2) 3 (10)(1)(11) 4 (20)(16)(36) 5 (22)(16)(38)  
 3.05 HID 1 (1)(2)(3) 2 (12)(12)(24) 3 (23)(9)(32) 4 (10)(7)(17) 5 (7)(3)(10)

Feeling of safeness: (55)(34)(89)

4.67 LED 1 (0)(0)(0) 2 (0)(1)(1) 3 (1)(0)(1) 4 (18)(6)(24) 5 (36)(27)(63)  
 2.97 HID 1 (2)(2)(4) 2 (11)(9)(20) 3 (12)(12)(24) 4 (27)(10)(37) 5 (3)(1)(4)

Feeling of comfortability/at ease (more comfortable=5): (55)(34)(89)

4.56 LED 1 (0)(0)(0) 2 (0)(1)(1) 3 (1)(4)(5) 4 (20)(6)(26) 5 (34)(23)(57)  
 3.39 HID 1 (0)(2)(2) 2 (11)(6)(17) 3 (16)(8)(24) 4 (19)(17)(36) 5 (9)(1)(10)

Overall Rating/preference: (55)(33)(88)

4.68 LED 1 (0)(0)(0) 2 (1)(0)(1) 3 (0)(2)(2) 4 (13)(8)(21) 5 (41)(23)(64)  
 2.89 HID 1 (2)(5)(7) 2 (18)(5)(23) 3 (21)(16)(37) 4 (9)(6)(15) 5 (5)(1)(6)

Can you read this sentence better in the LED or HID lighting?

LED (7)(9)(16)HPS (0)(1) (1)

Comments:

- LED can be more “harsh” than HPS
- I like the HPS yellowness on the limestone facades of the buildings. The LEDs are a little too harsh bright even though I feel the HPSs are better.
- I like to be able to distinguish objects and their color. The LED is much better for giving true color. Both provide enough light, but the HPS doesn't allow for me to distinguish objects very well.
- HPS=bad color rendering; LED=lamp heat issue
- LED seems brighter and safer than the HPS.
- Casts less of a shadow compared with HPS “cleaner”
- It just looks more natural (LED)
- If energy consumption was considered I might prefer LED but the atmosphere created by the HPS was better. Also, its harder to compare with just one LED example
- One HPS was buzzing. That's annoying but its probably an older lamp. I don't think the LED will ever buzz.
- LED was nicer/brighter than I expected. HPS looks crappy in comparison.
- LED provides brighter, cleaner lighting
- Feeling of comfort tied directly to colors shown in light. LED shows more color, therefore there are more things to observe, which increases comfort level.
- I like the LED lights better, but I also like the feeling that the HID's give off, they make me feel more comfortable.

- Colors are much better for LED.
- The LED makes objects look nicer than the HID. Makes things more visible.
- LEDs are far better than HID.
- HID seem to have more glare when looking at them. Hard to tell some lighting effects from my angle, but I definitely prefer the LED even though I rated HID with better lighting on some categories.
- LED is better for point focus and brightness. I prefer LED :)
- LED provides light that gives better color and makes for a safer feeling.
- LEDs make it seem very comparable to day outside on campus (not in color) but HIDs make me feel unaware of surroundings. HIDs are not attractive.
- LED lights are cool and safe.
- LED is a ton better.
- LEDs are much better in my opinion.
- I felt the LED lights are more safer and much brighter than the HID lights.
- I like the ambiance the HID creates. I think the light distribution is more consistent but is not as bright as the LED. The LED seems to lose intensity the farther from the light source. It also produces a cleaner looking light.
- LED provides a much more comfortable and well lit space as well as a more true to color lighting. also more effective.
- LEDs are better.
- I like the change to LED to me it is much cleaner and softer feeling. I feel the change will brighten up the downtown area.
- Go LED!
- I like the "old" look of the HPS lights on Poyntz because it matches the downtown atmosphere, but I like the modern bright clear glass look of the LED lights.
- The LED lights are more pleasing to my eyes
- I feel that HPS is appropriate to the overall feel of the city and it is softer, but LED is crisper and clearer but I like the feel of HPS. This is hard.
- Love the LEDs. Glad for the change.
- LED is a little "harsh" sometimes a softer light isn't a bad thing.
- Go LED! ☺
- LED looks more updated/"newer" in general whereas the HID looks outdated. Go LED!
- LED is much better-gives a daylight feel which is appealing at night, walking down the sidewalk.
- Definitely prefer the LED b/c of it's color rendering & feeling of visual brightness in comparison to HID. It feels "sharper." It does change the limestone more to white than tan, but I prefer this.
- The LED provides a cleaner & more crisp light & is more visually appealing. The LEDs seemed more consistent in color whereas the HID seemed to have varying color output through the different lamps.
- LEDs look more attractive, HID lights look cheap in a sense, or old.
- LEDs good. HPS "old town" feel.



- I am very much an aesthetics type of person, so I really enjoy the HID, but at the same time, it's hard to see in it. I don't like the "feel" of the LED. It makes the streets too sterile looking. But, being a girl, I like the "brighter" light. Wish there was a medium between the two for color.
- LEDs more shadow because brighter light, but feel safest.
- It's a lot easier to distinguish objects in the dark (even from far away) with the LED lighting. I would feel safer at night with the LED lights on Poyntz and would be more apt to spend time downtown during the night. Also the LED lights help bring out the texture of the limestone facades better to make the building more aesthetically pleasing.

## Appendix C - Survey Results - Percentages

Are you: **Male(62%)** or **Female(38%)** **Total(89)**

\*If the response was "same" or "both" for any of the following questions, it was not counted in the results.

Which light source is brighter/puts out more light?

LED **(87%)(94%)(90%)** HPS **(13%)(6%)(10%)**

Which light source do you feel safer in?

LED **(92%)(100%)(95%)** HPS **(8%)(0%)(5%)**

Which light source do you feel more comfortable and at ease in?

LED **(78%)(77%)(78%)** HPS **(22%)(23%)(22%)**

Which light source do you prefer?

LED **(83%)(88%)(85%)** HPS **(17%)(12%)(15%)**

Which light source provides better light on the sidewalk?

LED **(98%)(97%)(98%)** HPS **(2%)(3%)(2%)**

Which light source provides better light on the building facades?

LED **(74%)(84%)(78%)** HPS **(26%)(16%)(22%)**

Which light source creates more accurate coloring of the building facades and signage?

LED **(92%)(97%)(94%)** HPS **(8%)(3%)(6%)**

**One male overall preferred HID**

Please rate each light source on a scale from 1 to 5 (with 5 being the best) in the following categories.

Illumination, the amount of light distributed by the light source: **(53)(34)(87)**

LED 1, 2 **(2%)(0%)(2%)** 3 **(9%)(3%)(6%)** 4, 5 **(89%)(97%)(92%)**

HID 1, 2 **(25%)(18%)(22%)** 3 **(47%)(59%)(52%)** 4, 5 **(23%)(28%)(26%)**

Uniformity/evenness of light distribution: **(54)(33)(87)**

LED 1, 2 **(2%)(3%)(2%)** 3 **(4%)(3%)(3%)** 4, 5 **(94%)(94%)(94%)**

HID 1, 2 **(20%)(21%)(20%)** 3 **(32%)(48%)(38%)** 4, 5 **(48%)(33%)(42%)**

Ease of reading: **(53)(34)(87)**

LED 1, 2 **(0%)(3%)(1%)** 3 **(6%)(0%)(3%)** 4, 5 **(94%)(97%)(96%)**

HID 1, 2 **(15%)(27%)(20%)** 3 **(45%)(35%)(41%)** 4, 5 **(40%)(38%)(39%)**

Ease of seeing and distinguishing objects: **(55)(34)(89)**

LED 1, 2 **(0%)(3%)(1%)** 3 **(2%)(0%)(1%)** 4, 5 **(98%)(97%)(98%)**

HID 1, 2 **(24%)(29%)(26%)** 3 **(45%)(47%)(46%)** 4, 5 **(31%)(24%)(28%)**

Color:how the light source affects the true color of objects and building signage: **(54)(34)(88)**

LED 1, 2 **(2%)(0%)(1%)** 3 **(7%)(0%)(5%)** 4, 5 **(91%)(100%)(94%)**

HID 1, 2 **(57%)(62%)(59%)** 3 **(24%)(32%)(27%)** 4, 5 **(19%)(6%)(14%)**

Lighting of the sidewalk: **(55)(34)(89)**

LED 1, 2 (0%)(0%)(0%) 3 (4%)(9%)(6%) 4, 5 (96%)(91%)(94%)  
 HID 1, 2 (26%)(21%)(24%) 3 (47%)(44%)(46%) 4, 5 (27%)(35%)(30%)

Lighting of the building facade: (54)(33)(87)

LED 1, 2 (4%)(0%)(2%) 3 (18%)(3%)(13%) 4, 5 (78%)(97%)(85%)  
 HID 1, 2 (25%)(43%)(31%) 3 (43%)(27%)(37%) 4, 5 (32%)(30%)(31%)

Feeling of safeness: (55)(34)(89)

LED 1, 2 (0%)(3%)(1%) 3 (2%)(0%)(1%) 4, 5 (98%)(97%)(98%)  
 HID 1, 2 (24%)(32%)(27%) 3 (22%)(35%)(27%) 4, 5 (54%)(32%)(46%)

Feeling of comfortability/at ease (more comfortable=5): (55)(34)(89)

LED 1, 2 (9%)(3%)(1%) 3 (2%)(12%)(6%) 4, 5 (98%)(85%)(93%)  
 HID 1, 2 (20%)(24%)(28%) 3 (29%)(24%)(27%) 4, 5 (51%)(53%)(52%)

Overall Rating/preference: (55)(33)(88)

LED 1, 2 (2%)(0%)(1%) 3 (0%)(6%)(2%) 4, 5 (98%)(94%)(97%)  
 HID 1, 2 (36%)(30%)(34%) 3 (38%)(49%)(42%) 4, 5 (26%)(21%)(24%)

Can you read this sentence better in the LED or HID lighting?

LED (100%)(90%)(94%) HPS (0%)(10%)(6%)

Comments:

See Appendix B

# Appendix D - Poyntz Avenue CAD Drawing

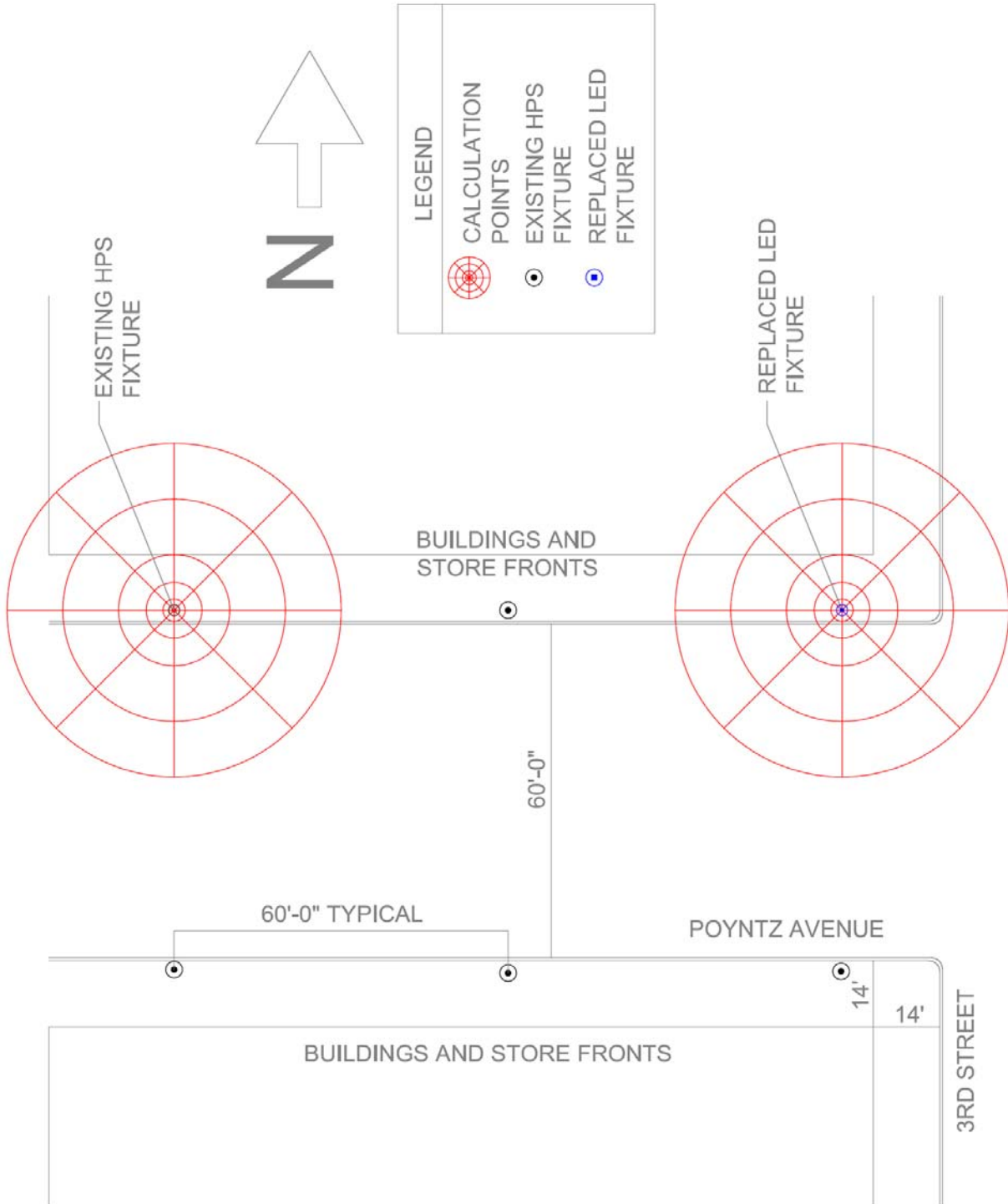

# Appendix E - Existing HPS Fixture Luminance Measurements

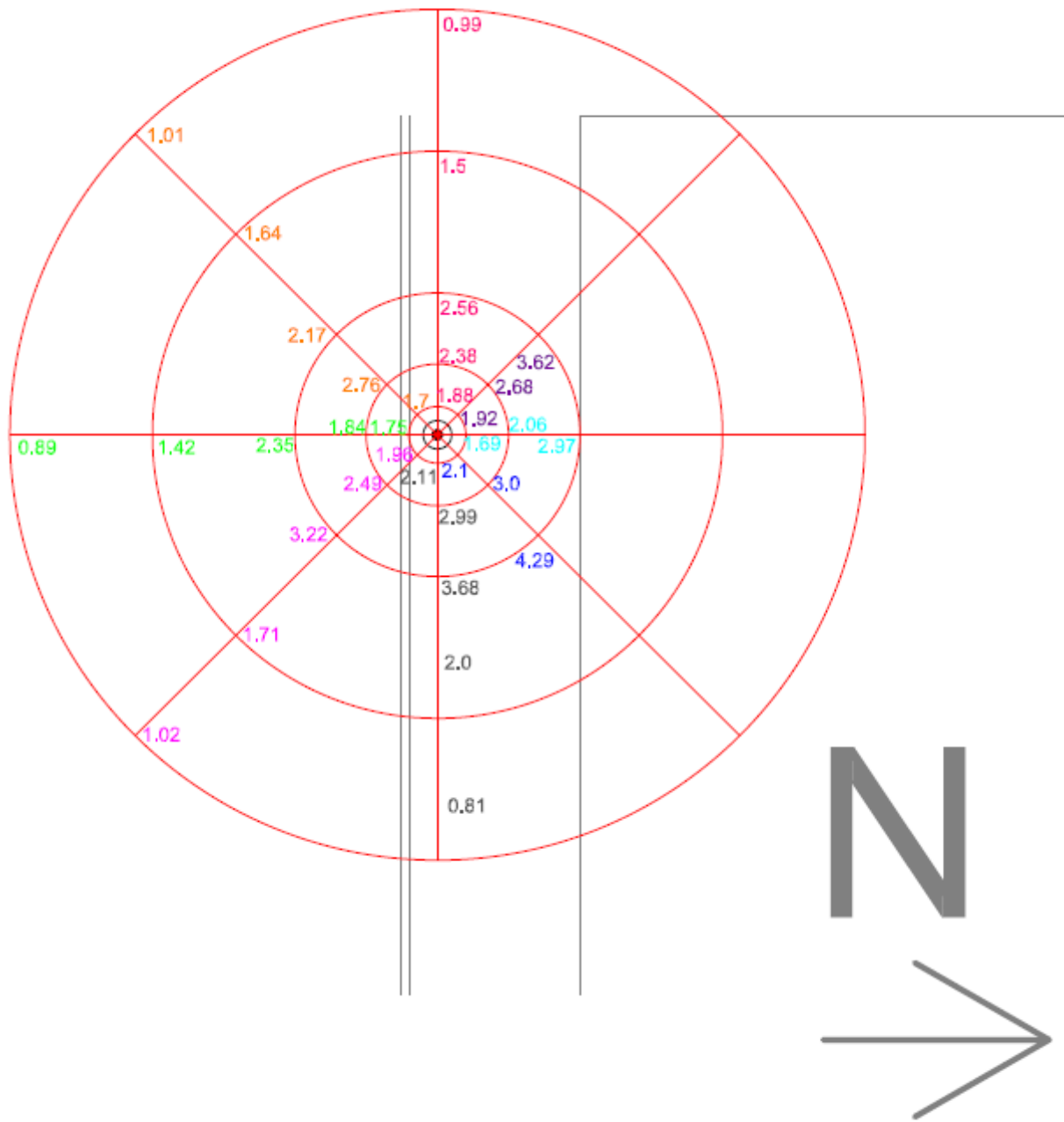

# Appendix F - Replaced LED Fixture Luminance Measurements

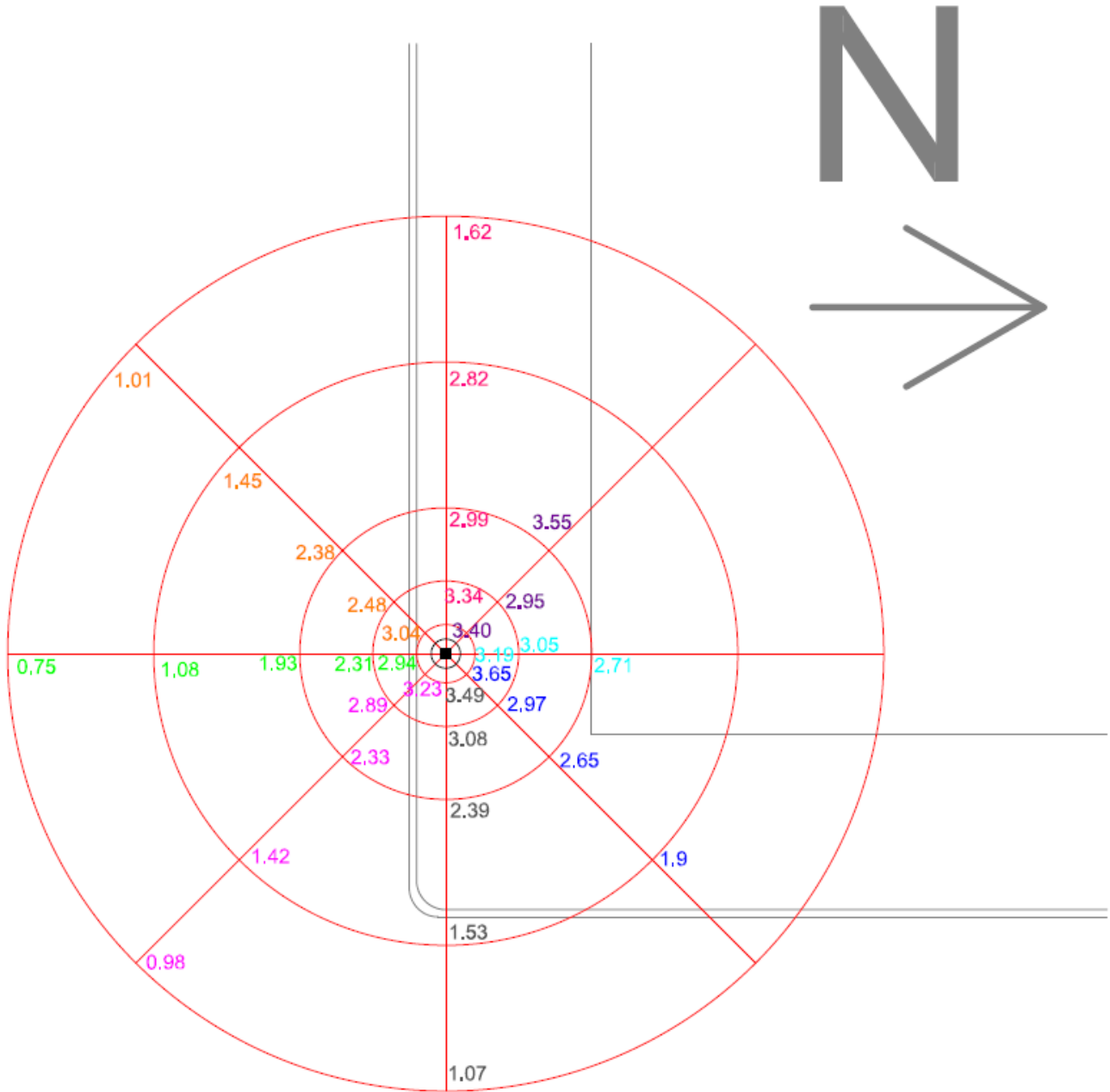

# Appendix G - Cut-Sheet, Poyntz Existing HPS Fixture

**STERNBERG**

Vintage Lighting Acorn Fixtures <sup>2-78</sup>

## A850/A850SR OLD TOWN SERIES

## SPECIFICATIONS

### GENERAL

The A850 Old Town series is a traditional acorn style fixture which consists of decorative cast aluminum fitter, cast ballast housing assembly and polycarbonate or acrylic clear textured acorn globe. It shall be appointed with a cast aluminum decorative 4-vane finial.

### FITTER - STANDARD

The fitter shall be heavy wall cast aluminum, 319 alloy for high tensile strength. It shall have an 8<sup>1/2</sup>" inside diameter opening to attach to the 8" neck of the acorn globe. When ordered with a Sternberg aluminum pole, the fitter shall be welded to the pole top or tenon for safety and to ensure the fixture will be plumb, secure and level over the life of the installation. The fitter shall have a one-piece ring bug gasket to resist insect penetration into lamp assembly.

### FITTER-TL FOR QUICK & TOOL-LESS REMOVAL OF ACORN (OPTIONAL)

The fitter shall be heavy wall cast aluminum, 319 alloy for high tensile strength. It shall have an 9<sup>1/4</sup>" inside diameter opening to attach to the 8" neck of the acorn globe. When ordered with a Sternberg aluminum pole, the fitter shall be set screwed to the pole top or tenon. The fitter shall have an aluminum die cast twist-lock mechanism for tool-less, 1/4 turn installation and removal of acorn globe. The acorn is provided with a die cast mating collar which is easily removed and reused if acorn replacement is ever performed.

### 980 FITTER OPTION

The fitter shall be heavy wall cast aluminum, 319 alloy for high tensile strength. It shall have a 9<sup>1/4</sup>" inside diameter opening to attach to the 8" neck of the acorn globe. It shall have a hinged, tool-less entry door that provides open access to all of the components. The 980 shall have a terminal block for ease of wiring, an optional Roto-Lock Photocell receptacle, an optional Single Convenience outlet or Single GFIC outlet for auxiliary power needs. The top mounted ballast mounting plate shall be cast aluminum and provide tool-less removal from the housing using 2 ea finger latches. When ordered with a Sternberg aluminum pole, the fitter shall be set screwed to the pole top or tenon. The fitter shall have a one-piece ring bug gasket to resist insect penetration into lamp assembly.

### 980 FITTER-TL FOR QUICK & TOOL-LESS REMOVAL OF ACORN (OPTIONAL)

The fitter shall be heavy wall cast aluminum, 319 alloy for high tensile strength. It shall have an 9<sup>1/4</sup>" inside diameter opening to attach to the 8" neck of the acorn globe. It shall have a hinged, tool-less entry door that providing an open access to all of the components. The 980 shall have a terminal block for ease of wiring, an optional Roto-Lock Photocell receptacle, an optional Single Convenience outlet or Single GFIC outlet for auxiliary power needs. The top mounted ballast mounting plate shall be cast aluminum and provide tool-less removal from the housing using 2 ea finger latches. When ordered with a Sternberg aluminum pole, the fitter shall be set screwed to the pole top or tenon. The fitter shall have an aluminum die cast twist-lock mechanism for tool-less, 1/4 turn installation and removal of acorn globe. The acorn is provided with a die cast mating collar which is easily removed and reused if acorn replacement is ever performed.

### BALLAST HOUSING

The ballast housing shall be heavy wall cast aluminum, 319 alloy for high tensile strength. The housing shall be cast as an integral part of the fitter to prevent water entry into the ballast compartment and to ensure high capacity heat sinking of ballast temperatures, keeping the ballast cooler and ensuring long life. The ballast mounting plate shall be cast aluminum and provide tool-less removal from the housing using 2 ea finger latches.

### ELECTRICAL

Fixture shall be U.L. or E.T.L. listed in U.S. and Canada. H.I.D. ballasts shall be high power factor with lamp starting down to -30 degrees C. Medium base and mogul base porcelain sockets are 4KV rated. The ballast/socket assembly

**See LED SECTION for Specifications on A850SR LED OLD TOWN SERIES**

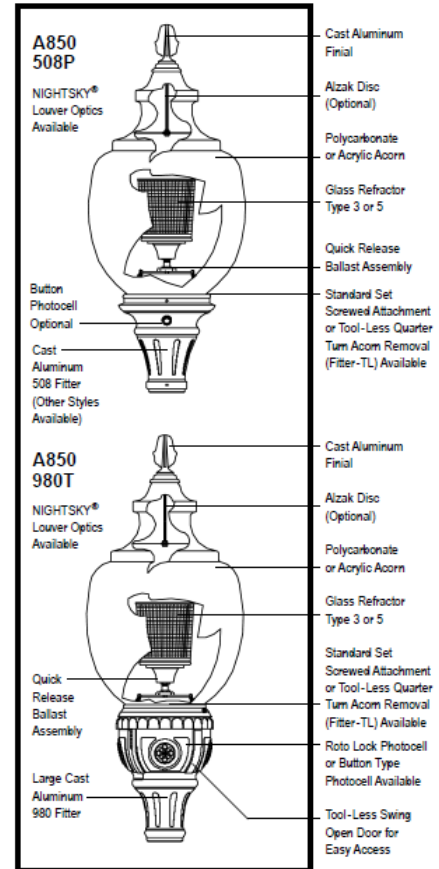

LIST NO.  
A850/A850SR  
OLD TOWN  
SERIES

10-09

**A850/A850SR OLD TOWN**

**ACORNS / FITTERS / ARMS PM - WB**

**ACORNS / OPTIONAL TOPS / OPTICAL SYSTEMS**

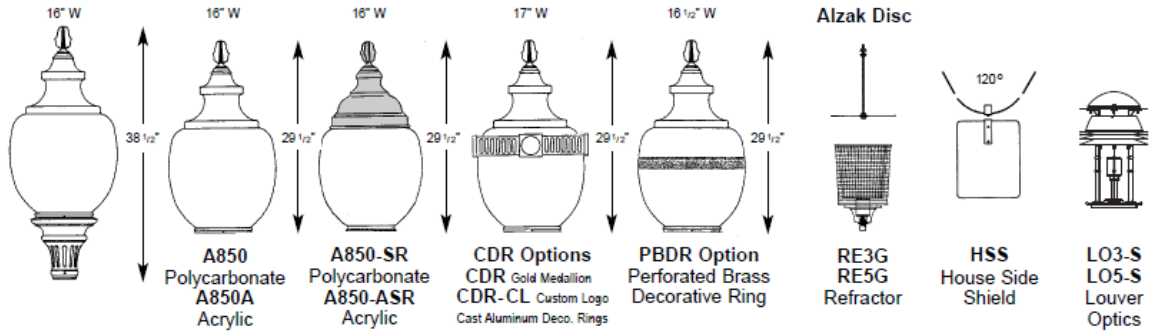

**FITTERS**

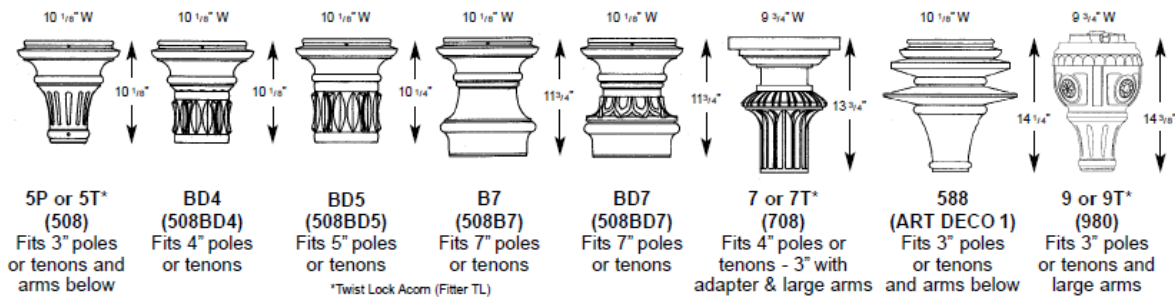

**ARMS - POST MOUNT (PM) or WALL BRACKETS (WB)** See Arms Section for more information

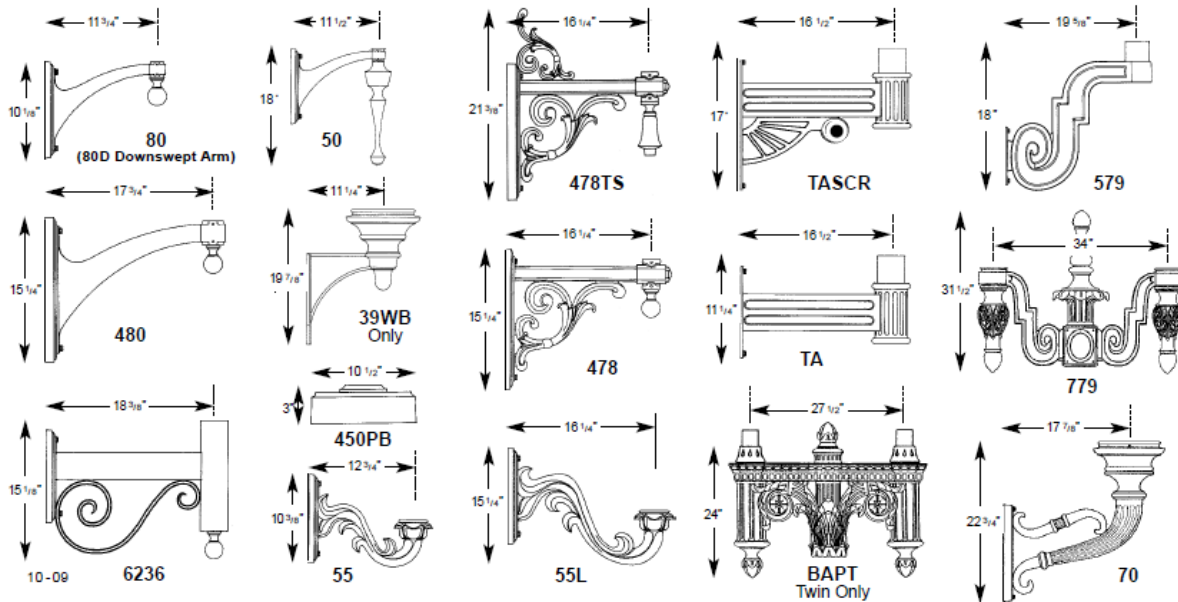





**BUILDING A PART NUMBER**

**POST & ARM FIXTURES**

ARM MOUNTED FIXTURE	CENTER POST TOP FIXTURE (PT)	POST	POST CAP	LIGHT SOURCE BALLAST	OPTICS	OPTIONS	FINISH
NO. OF ARMS	ACORN / FITTER / POSTARM	ACORN / FITTER	(See Post Section)	WATTS / TYPE / VOLTS			
2	A850 / 5P / 50PM	A850 / 5P	PT	4212 FP4		100 HPS120	RE5G / B1/QR / BK



**WALL FIXTURES**

ACORN / FITTER / WALLBRACKET	LIGHT SOURCE BALLAST	OPTICS	OPTIONS	FINISH
A850 / 5P / 50WB	100 HPS120	RE5G	PEC1	BK



**PIER FIXTURES**  
Uses same information boxes as wall fixture

ACORN / FITTER / PIER BASE

**PART NUMBER SELECTIONS**

- ACORNS<sup>3</sup>**
- A850
  - A850A
  - A850SR
  - A850ASR

- FITTERS**
- 5P
  - 5T
  - 7
  - 7T
  - 9
  - 9T
  - BD4
  - BD5
  - BD7
  - B7
  - 588

- POST ARMS**
- 50PM
  - 50DPM
  - 478PM
  - 478TSPM
  - 70PM\*\*
  - 80PM
  - 80DPM
  - 480PM
  - 480DPM
  - 55PM
  - 55LPM
  - 6236PM
  - 579PT
  - TAPT
  - TASCRPT
  - BAPT

- PIER BASE**
- 450PB

- WALL BRACKET ARMS**
- 50WB
  - 50DWB
  - 478WB
  - 478TSWB
  - 70WB\*\*
  - 80WB
  - 80DWB
  - 480WB
  - 480DWB
  - 55WB
  - 55LWB
  - 6236WB
  - 579WB
  - TAWB
  - TASCRWB
  - 39WB\*\*

\*\*No fitter required

- BALLASTS<sup>4,7</sup>**
- 35HPS<sup>1</sup>
  - 50HPS
  - 70HPS
  - 100HPS
  - 150HPS
  - 250HPS
  - 50MHP
  - 70MHP
  - 100MHP
  - 150MHP
  - 175MHP<sup>5</sup>
  - 200MHP
  - 250MHP
  - 26PLT
  - 32PLT
  - 42PLT
  - 57PLT
  - 70PLT7
  - 60PLH
  - 85PLH
  - 120PLH
  - INCAND
  - QL55\*
  - QL85\*
  - QL165\*

\*Consult Factory for Specification Details

- OPTICS**
- RE3G
  - RE5G
  - ALZAK
  - HSS
  - LO3-S
  - LO5-S

- LAMPS<sup>7</sup>**
- HPS35/MED
  - HPS50/MED
  - HPS70/MED
  - HPS100/MED
  - HPS150/MED
  - HPS250/MOG/ED18
  - MHP50/MED
  - MHP70/MED
  - MHP100/MED
  - MHP150/MED
  - MHP175/MOG/ED28<sup>5</sup>
  - MHP200/MOG/ED28
  - MHP250/MOG/ED28
  - PLT26
  - PLT32
  - PLT42
  - PLT57
  - PLT70
  - PLH60
  - PLH85
  - PLH120

- VOLTAGES**
- 120
  - 208
  - 240
  - 277
  - 480
  - MULTI (120-277)

**FINISHES STANDARD**

- BKT Black Textured
- BK Black
- VG Verde Green
- PGT Park Green Textured
- PG Park Green
- ABZT Architectural Medium Bronze Textured
- ABZ Architectural Medium Bronze
- SI Swedish Iron
- DBT Dark Bronze Textured
- DB Dark Bronze
- OWGT Old World Gray Textured
- OWG Old World Gray

**FINISHES CUSTOM**

- WHT White Textured
- WH White
- CV Copper Vein
- WBK Weathered Black
- WBR Weathered Brown
- CD Cedar
- RT Rust
- OI Old Iron
- TT Two Tone
- CM Custom Match

**NOTES:**

- <sup>1</sup> 35HPS is 120 volt only.
- <sup>2</sup> Standard is polished. If painted specify PBDR-P.
- <sup>3</sup> White polycarbonate acorns are available specify WP after acorn number.
- <sup>4</sup> Medium base sockets standard with ballasts up to 150 watts. Mogul base sockets are standard with ballasts 175 watts and over. 4-pin for PL.
- <sup>5</sup> Consult factory for limitations.
- <sup>6</sup> For 9 or 9T fitter only.
- <sup>7</sup> Metal halide systems are pulse start.



555 Lawrence Ave. Roselle, IL 60172 • 847-588-3400 • Fax 847-588-3440  
www.sternberglighting.com Email: info@sternberglighting.com 10-09

**A850 /A850SR OLD TOWN SERIES****SPECIFICATIONS****LIST NO.  
A850 /A850SR  
OLD TOWN  
SERIES**

shall be pre-wired when ballast is located in the fitter. All compact fluorescent (PL) ballasts shall be instant start electronic with a starting temperature of down to -10 degrees F. They shall have a 4-pin socket to accept quad or triple tube lamps. The QL Induction System option provides 5-10 times the life of HID lamps and provides Instant on-Instant restrike. Ballasts shall be DOE EISA compliant.

**ACORN GLOBE**

The acorn globe shall be 16" in diameter and 29½" tall with an 8" diameter neck. It will be made of vandal resistant clear textured polycarbonate or dent resistant (DR) clear textured acrylic. White textured polycarbonate is also available. The acorn globe is available in a solid roof (A850SR) for added distinction and reduced up-light. The solid roof will be made of spun aluminum and securely affixed to the top of the acorn. The optional perforated brass decorative ring (PBDR) is available in polished brass or painted finish. The 2¼" wide brass filigree allowing light transfer through decorative openings. The optional CDR is a heavy cast aluminum ring with four cast medallions finished in accent gold. Also available are custom medallions that can be specified with a name, initial or logo.

**OPTICAL OPTIONS**

Refractors shall be 6" diameter borosilicate glass with an I.E.S. Type 3 or 5 distribution. It shall be secured to the socket stem with 3/8" plated steel threaded pipe nipple and rest on a cast aluminum holder with anti-shock gasket. The refractor will be secured to cast holder with a quarter-turn internal aluminum twist ring for ease of maintenance. The optional Alzak disk is an optical shield to help direct light downward. It shall be 7" diameter and made of specular reflective aluminum and mounted directly above lamp. The NIGHTSKY® OPTI-SHIELD® Louver Optic System (LO-S) shall be a multi-tier reflector with 7" diameter rings to produce an I.E.S. Cut-off Type 3 or 5 distribution. The Louver Optic System shall be made of highly specular anodized aluminum and shall come standard with medium base socket. House Side Shields (HSS) will block 120° of light in any one direction.

**QUARTZ RESTRIKE**

The A850 fixture can be supplied with optional quartz re-strike system to retain constant fixture light if the H.I.D. lamp fails. The fixture will be equipped with a 100 watt quartz lamp and a controller to run on a 120 volt circuit and must be used in conjunction with a 120 volt or multi-tap ballast.

**PHOTOCELLS**

Photocells shall be either the thermo bi-metal button type or the electronic button type. On single post top fixtures the photocell shall be mounted in the fitter and pre-wired to ballast. On multiple head fixture assemblies photocells shall be mounted in the pole shaft on an access plate and are not pre-wired as ballast housing assemblies and fitters are packaged separately for ease of wiring to source. The thermo bi-metal photocell shall be designed to turn on at 1.0 footcandle and turn off at not more than 5 footcandles. The electronic button type photocell is instant on and a 5-10 second turn off and shall turn on at 1.5 footcandles with a turn-off at 2-3 footcandles. Photocells are either 120 volt or 208 thru 277 volt.

**ARMS**

All arms are made of cast aluminum and/or extruded aluminum. Arms with decorative filigree have meticulously detailed scroll work and gracefully curved brackets. All A850 fixtures will have its fitter either welded to the arm or will be mechanically attached at the factory to ensure arms will be plumb, secure and level over the life of the installation. Most arms shall be bolted to a post mount adapter, which is welded to the pole to ensure proper alignment to the base. Twin TA, TASCRA and 579 arms will be attached to a decorative center hub which will slip-fit the center tenon of the pole (not shown). BA and 779 arms are available as a twin application. Arms are pre-wired for ease of installation.

**FINISH**

Prior to coating, each assembly shall be chemically cleaned & etched in a 5-stage washing system which includes alkaline cleaning, rinsing, phosphoric etching, reverse osmosis water rinsing, and non-chrome sealing to ensure corrosion resistance and excellent adhesion for the finish coating. The finish coating shall be electrostatically applied semi-gloss, super durable polyester powder baked at 400 degrees for a durable and superior, color retentive finish. Our optional antique Verde Green finish and Swedish Iron finish are hand brushed using a 3-step process. The total assembly shall be wrapped in shockproof wrapping or fully enclosed in corrugated cartons.

**WARRANTY**

Five-year limited warranty. See product and finish warranty guide for details.



**STERNBERG**  
LIGHTING

555 Lawrence Ave. Roselle, IL 60172 • 847-588-3400 • Fax 847-588-3440  
www.sternberglighting.com Email: info@sternberglighting.com 10-09

# Appendix H - Cut-Sheet, Poyntz Proposed LED Fixture

**STERNBERG**

*18-737*  
**Vintage Lighting Acorn Fixtures**

## **A850SR LED OLD TOWN SERIES**

## **SPECIFICATIONS**

### **LUMINAIRE DESIGN**

- The luminaire shall be a traditional acorn style fixture provided with a decorative cast aluminum fitter, a polycarbonate or acrylic clear textured acorn and a cast aluminum roof.
- The luminaire shall have LED light sources and roof mounted, down-lighting optics.
- The luminaire shall be 16" diameter and 40 1/2" overall height.
- The luminaire shall be supplied with line-ground, line-neutral and neutral-ground electrical surge protection in accordance with IEEE/ANSI C62.41.2 guidelines.
- The luminaire shall be U.L. or E.T.L. listed in U.S. and Canada.

### **POST FITTER**

- The fitter shall be heavy wall cast aluminum for high tensile strength.
- The fitter shall have an inside diameter opening of 8 1/2" to attach to the 8" neck of the acorn globe.
- When ordered with a Sternberg pole, the fitter shall be welded to the pole top or tenon to ensure safety and to ensure the luminaire will remain plumb and level over the luminaire life.

### **DRIVER**

- The LED driver shall be securely mounted inside the fitter, for optimized performance and longevity.
- The LED driver shall be supplied with a quick-disconnect electrical connector on the power supply, providing easy power connections and fixture installation.

### **LIGHT SOURCES**

- The luminaire shall use high output, high brightness LEDs.
- The LEDs shall be mounted in arrays, on printed circuit boards designed to maximize heat transfer to the heat sink surface.
- The LEDs shall be attached to the printed circuit board with not less than 90% pure silver to insure optimal electrical and thermal conductivity.
- The LEDs and printed circuit boards shall be protected from moisture and corrosion by a conformal coating of 1 to 3 mils.
- The LEDs and printed circuit board construction shall be environmentally friendly and 100% recyclable. They shall not contain lead, mercury or any other hazardous substances and shall be RoHS compliant.
- The LED life rating data shall be determined in accordance with IESNA LM-80-08.

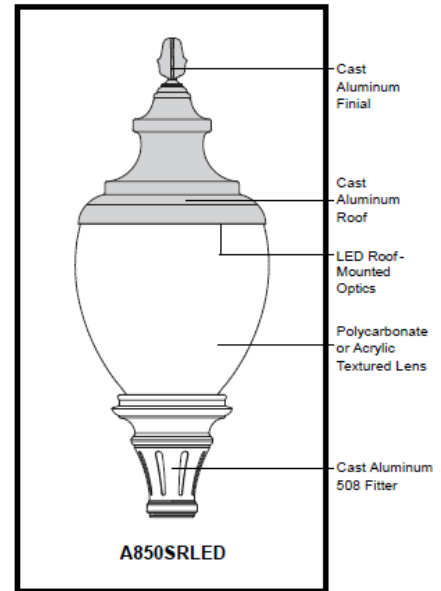

**Rated IP65**

*LIST NO.*  
**A850SR LED**  
**OLD TOWN**  
**SERIES**

8-10

*(Continued on next page)*

**A850SR LED OLD TOWN SERIES SPECIFICATIONS**

LIST NO.  
A850SR LED  
OLD TOWN  
SERIES

**OPTICS**

- The luminaire shall be provided with individual, acrylic, refractor type optics applied to each LED.
- The luminaire shall provide Type \_\_\_ (III or V) light distribution per the IESNA classifications. Testing shall be done in accordance with IESNA LM-79-08.

**PERFORMANCE**

- The LED arrays are built in series-parallel circuits which maintain overall light output in the event of single LED failures.
- The LEDs and LED driver shall operate over a -40°C (-40°F) to +50°C (122°F) ambient air temperature range.
- The High Performance white LEDs will have a life expectancy of approximately 70,000 hours with not less than 70% of original brightness (lumen maintenance), rated at 25°C.
- The High Brightness, High Output LED's shall be 4500K (3500K or 6000K option) color temperature with a minimum of 75 CRI.
- The luminaire shall have a minimum \_\_\_\_\_ (see table) initial delivered lumen rating when operated at steady state with an average ambient temperature of 25°C (77°F).

Light Source	Initial Delivered Lumens	Fixture Watts	Light Source	Initial Delivered Lumens	Fixture Watts
6ARC60T5	6520	96	6ARC60T3	6320	96
6ARC45T5	5420	96	6ARC45T3	5210	96
6ARC35T5	4840	96	6ARC35T3	4650	96
4ARC60T5	4410	66	4ARC60T3	4270	66
4ARC45T5	3680	66	4ARC45T3	3530	66
4ARC35T5	3300	66	4ARC35T3	3160	66
3ARC60T5	3460	51	3ARC60T3	3210	51
3ARC45T5	2910	51	3ARC45T3	2660	51
3ARC35T5	2600	51	3ARC35T3	2380	51
2ARC60T5	2290	35	2ARC60T3	2110	35
2ARC45T5	1920	35	2ARC45T3	1750	35
2ARC35T5	1730	35	2ARC35T3	1560	35

**ELECTRONIC DRIVERS**

- The driver shall be UL Listed or Recognized.
- The driver shall have overload as well as short circuit protection.
- The driver shall be a DC voltage output, constant current design, 50/60HZ.

**For 3ARC thru 6ARC LED Light Sources**

- The driver shall have a minimum efficiency of 90%.
- The driver shall be rated at full load with THD<20% and a power factor of greater than 0.90.



555 Lawrence Ave. Roselle, IL 60172 • 847-588-3400 • Fax 847-588-3440  
www.sternberglighting.com Email: info@sternberglighting.com 8-10

**A850SR LED OLD TOWN SERIES**

**SPECIFICATIONS**

LIST NO.  
A850SR LED  
OLD TOWN  
SERIES

- The driver shall contain over-heat protection which reduces output to less than half rating if the case temperature reaches 85°C.

**For 2ARC LED Light Sources**

- The driver shall have a minimum efficiency of 88%.

**ACORN**

- The acorn shall be 16" diameter and 31<sup>1</sup>/<sub>2</sub>" tall with an 8" diameter neck.
- \*The acorn LED assembly shall be retro-fitted to a \_\_\_\_\_ (competitor) fitter which accepts the standard 8" diameter acorn neck. Consult Sternberg factory.
- The acorn shall be made of \_\_\_\_\_ (vandal resistant, clear textured polycarbonate or dent resistant (DR) clear textured acrylic. For Acrylic add "A" to model number.
- The acorn shall be supplied with a cast aluminum finial and a solid, cast aluminum roof which includes optimized heat sinks to provide maximum life and performance for the LED light sources.
- The acorn shall be sealed to the cast aluminum roof to provide a moisture-free and bug-free optics chamber for the LED light sources and **Rated IP65**.
- \*The acorn shall be provided with a perforated brass decorative ring (PBDR) supplied in a \_\_\_\_\_ (polished brass or painted) finish. The 2<sup>1</sup>/<sub>4</sub>" wide brass filigree shall allow light transfer through the decorative openings.
- \*The acorn shall be provided with a heavy cast decorative ring (CDR) which includes four (4) cast medallions finished in accent gold. The medallions can be customized with name, initials or logo. \* (OPTION)

**ARMS**

- The arms shall be cast aluminum and/or extruded aluminum.
- Arms with decorative filigree shall have meticulously detailed scroll work and gracefully curved brackets.
- **(All except BAPT and 779 arms)** The arms shall be bolted to a post mount adaptor which is welded to the pole to ensure proper alignment.
- **(Twin TA and twin 579 arms)** The arms shall be attached to a decorative center hub which will fit the center tenon of the pole (not shown).

**PHOTOCELL OPTIONS**

**Bi-metal Button Cell Option**

- Photocells shall be thermo bi-metal button type.
- On single post-top fixtures, the photocell shall be mounted in the fitter and pre-wired to the driver.

**A850SR LED OLD TOWN SERIES SPECIFICATIONS**

LIST NO.  
A850SR LED  
OLD TOWN  
SERIES

- On multiple head fixtures, photocells shall be mounted in the pole shaft, on an access plate. The photocell is not pre-wired since drivers are mounted in the fitters and packaged separately.
- The photocell shall turn on at 1.0 foot-candle and turn off at not more than 5 foot-candles.
- The photocell is 120V or 208-277 volt.

**Electronic Button Cell Option**

- Photocells shall be electronic button type.
- On single post-top fixtures, the photocell shall be mounted in the fitter and pre-wired to the driver.
- On multiple head fixtures, photocells shall be mounted in the pole shaft, on an access plate. The photocell is not pre-wired since drivers are mounted in the fitters and packaged separately.
- The photocell is instant-on at 1.5 foot-candles and turns off 5-10 seconds at 2-3 foot-candles.
- The photocell is 120V or 208-277 volt.

**Roto-Lock Type Option (980 fitter only)**

- Photocells shall be roto-lock design.
- They shall be thermal-bimetallic switch type.
- Photocells shall be mounted in the housing on the photocell bracket and pre-wired to the driver.
- On multi-fixture poles the photocell shall be mounted in the pole shaft on an access plate. The photocell is not pre-wired since drivers are mounted in the fitters and packaged separately.
- Photocell time delay is 2 minutes to turn on at 1.5 foot-candles and 2 minutes to turn off at no more than 6 foot-candles.
- The photocell is 120-277 volt.

**FINISH**

- Prior to coating, the luminaire shall be chemically cleaned and etched in a 5-stage washing system which includes alkaline cleaning, rinsing, phosphoric etching, reverse-osmosis water rinsing and non-chrome sealing to ensure corrosion resistance and excellent adhesion for the finish coat.
- The finish coat shall be an electrostatically applied semi-gloss, super durable polyester powder coat, baked on at 400°F, to provide a durable, color retentive finish.
- \*The optional \_\_\_\_\_ (Verde Green or Swedish Iron) finish shall be hand-brushed using a 3-step process. \* (OPTION)

**WARRANTY**

- The luminaire shall be free from all defects in materials and workmanship for a period of seven (7) years from the date of manufacture.
- The luminaire manufacturer shall warrant the LED boards/system, during the stated warranty period, against failure defined as more than three (3) simultaneous non-operating LEDs.
- The driver shall be warranted for seven (7) years.



555 Lawrence Ave. Roselle, IL 60172 • 847-588-3400 • Fax 847-588-3440  
www.sternberglighting.com Email: info@sternberglighting.com 8-10