

ADAPTIVE-USE DESIGN FOR THE IOOF HALL
IN GARNETT, KANSAS

by

LICHANG JIN

B. Arch, Tianjin University, CHINA, 1981
Master of Urban Planning & Design, Tianjin University, CHINA, 1985

A THESIS

Submitted in partial fulfillment of the
requirements for the degree

MASTER OF ARCHITECTURE

Department of Architecture
College of Architecture and Design

KANSAS STATE UNIVERSITY
Manhattan, Kansas

1992

Approved by:

Bernd Foerster

Professor Bernd Foerster
Major Advisor

LD
2668
.T4
ARCH
1992
J56
C.2

A Master's Thesis



A11210 196799

ADAPTIVE-USE DESIGN FOR
THE IOOF HALL

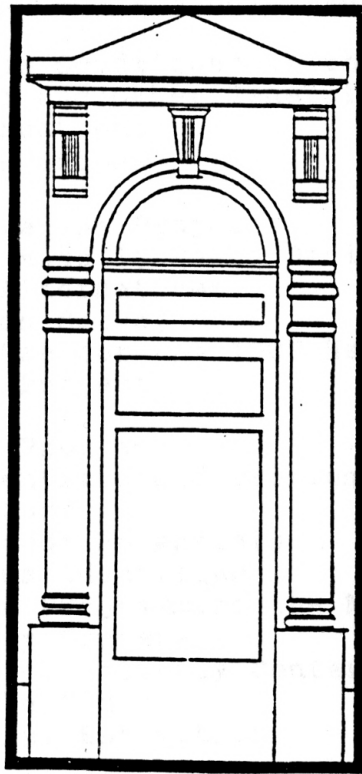

LICHANG JIN

DEPARTMENT OF ARCHITECTURE
KANSAS STATE UNIVERSITY

May 13, 1992

TABLE OF CONTENTS

Page

ACKNOWLEDGEMENT	iii
INTRODUCTION	1
PART ONE: PROGRAM STUDY		
Chapter 1 Background of Project	7
<1> Historic Downtown Garnett and the IOOF Hall	7
<2> The IOOF and the IOOF Hall	19
<3> Present Garnett and Its Downtown	25
Chapter 2 Existing Conditions of the IOOF Hall	33
<1> Site Condition and Other General Data	33
<2> Exterior Observations	39
<3> Interior Observations	49
Chapter 3 Adaptive-Use Proposal	77
<1> Three Reasons Make It Worth Saving	77
<2> Preservation Alternatives	78
<3> Community Needs Survey	79
<4> Proposed New Use for the IOOF Hall	83
<5> Objectives of Project	85
Chapter 4 Design Program	87
<1> Exploring Potentials and Problems with the Old Structure	88
4.1-1 Some Major Potentials	88
4.1-2 Problems Identified	90
<2> Three Steps in Programming the New Function	92
4.2-1 Activity Centers	93
4.2-2 Are These Activity Center Possible with the Old ?	95
4.2-3 A Spatial Estimation	97
<3> Proposed Facilities	100
PART TWO: DESIGN STUDY		
Chapter 5 Precedent Study	102
<1> Adaptive-Use in Downtown Revitalization	102
<2> Adaptive-Use for Community Usage	108
Chapter 6 Design Strategy	119
<1> Alternative Models	119
6.1-1 "Shell Model"	119
6.1-2 "Fragment Model"	123
6.1-3 "Annex Model"	125
<2> Proper Solution	130
<3> Other Design Strategies	133

6.3-1	For the Existing Structure	133
6.3-2	For the New Addition	134
Chapter 7	Design Decisions	136
<1>	Thinking From Top To Bottom: Demolitions	136
7.1-1	Third Floor	136
7.1-2	Second Floor	138
7.1-3	First Floor	141
<2>	Thinking From Outside To Inside: New Addition	143
7.2-1	Facades	143
7.2-2	New Floor Plans	146
7.2-3	Sections	154
7.2-4	Detailing	157
<3>	Other Key Issues	161
7.3-1	Barrier-Free Environment	161
7.3-2	Recycled Materials	163
7.3-3	Parking and Other Site Factors	163
Chapter 8	Conclusions	167
BIBLIOGRAPHY		170
LIST OF DRAWINGS		173
ABSTRACT			

ACKNOWLEDGEMENTS

I thank Professor Bernd Foerster, my major advisor, for his indispensable guidance. Acknowledgements and thanks are also due to Professor Ray Weisenburger and Professor Gwen Owens-Wilson for their valuable time and assistance.

In addition, I want to thank Ms. Catherine Sayers, Mr. Robert Logan, Mr. Robert Cugno, Mr. Stanley Morey, Ms. Lora Muther, Mrs Dianne Rogers, and many other people in Garnett, Kansas, for their support, especially for their enthusiastic participation in my field investigation and survey study. I also want to thank Ms. Sarah Alfonso, who has edited the whole manuscript.

I am deeply indebted to my wife, Lina. Without her consistent support, both materially and emotionally, this thesis would not be possible.

INTRODUCTION

This thesis addresses an adaptive-use design for the IOOF¹ Hall in Garnett, Kansas. It is a project-oriented thesis which explores a design process. It has two parts: part one includes collecting the background materials of the building, surveying the existing conditions of the structure, and writing a design program for the proposed use for the building; part two includes reviewing precedents for design considerations and formulation of design decisions, accompanied by a set of design drawings.

The IOOF Hall in downtown Garnett, Kansas, was built in 1883 - 1884 originally as a bank. Shortly after it was erected, its third floor started to house the Garnett Lodge of the IOOF and it became known in the community as the IOOF Hall. After enjoying prominence and glory for almost a century, the building became vacant in the 1980s. It was left as it was in terms of its interior decoration and spatial structure. Before it was abandoned, the occupancy pattern of the building was: the IOOF Garnett Lodge occupied its upper two floors, a fitness shop and a real estate office occupied its first floor. The whole building is still owned by the IOOF Garnett Lodge.

As the term itself indicates, "adaptive-use" assumes an alteration of the original use of the building. It aims at adapting an existing building to new uses. Judged by today's standard, the

¹. "IOOF" stands for the Independent Order of Odd Fellows. See detailed description in Section Three of Chapter One.

IOOF Hall is awkward and inefficient, yet, it is one of the oldest structures in the downtown area. It is a fine example of a late 19th century stone and brick structure located in the mid-west. It stands at an important location downtown, and has an urbanistic role in the streetscape. It is one of the better preserved buildings in the community, structurally and artistically. How might the building be saved? In a small town like Garnett where historic preservation is unfamiliar, adaptive-use is usually a good way to preserve a building. "A convincing argument for preservation must rest on objective data showing that the property will remain useful in the community and will continue to pay its way, though very possibly in a role that its builders never imagined."²

Early in the 1990 Fall semester, during the first visit to Garnett with a class from ARCH 746: Urban Planning and Preservation Design Studio, led by Professor Ray Weisenburger, the author found that both the shape of the building and the current needs of the community indicated that an adaptive-use design for this building necessary and of value. Consequently the author made three other trips to the site and conducted a detailed field survey including a set of measured drawings of the IOOF Hall. The study of existing conditions of the building convinced the author that there are both potentials and problems for the adaptation. This has made the author believe that such a project will bring about radical improvements to the downtown area.

². Ziegler, Authur P., Historic Preservation in Small Towns, 1980, pp. 49.

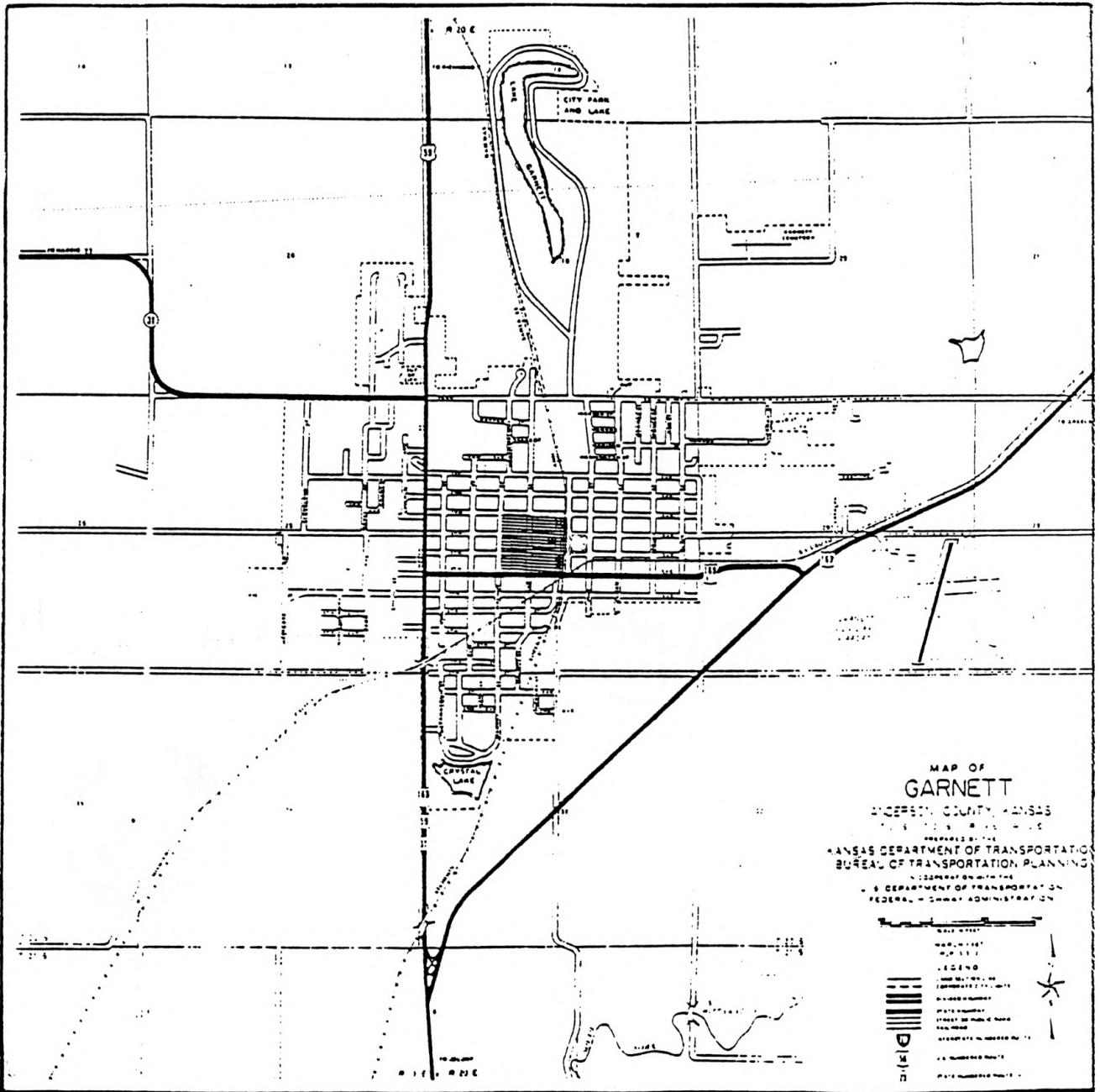

Map <1>

City of Garnett in 1989 and Location of Downtown

Source: City of Garnett

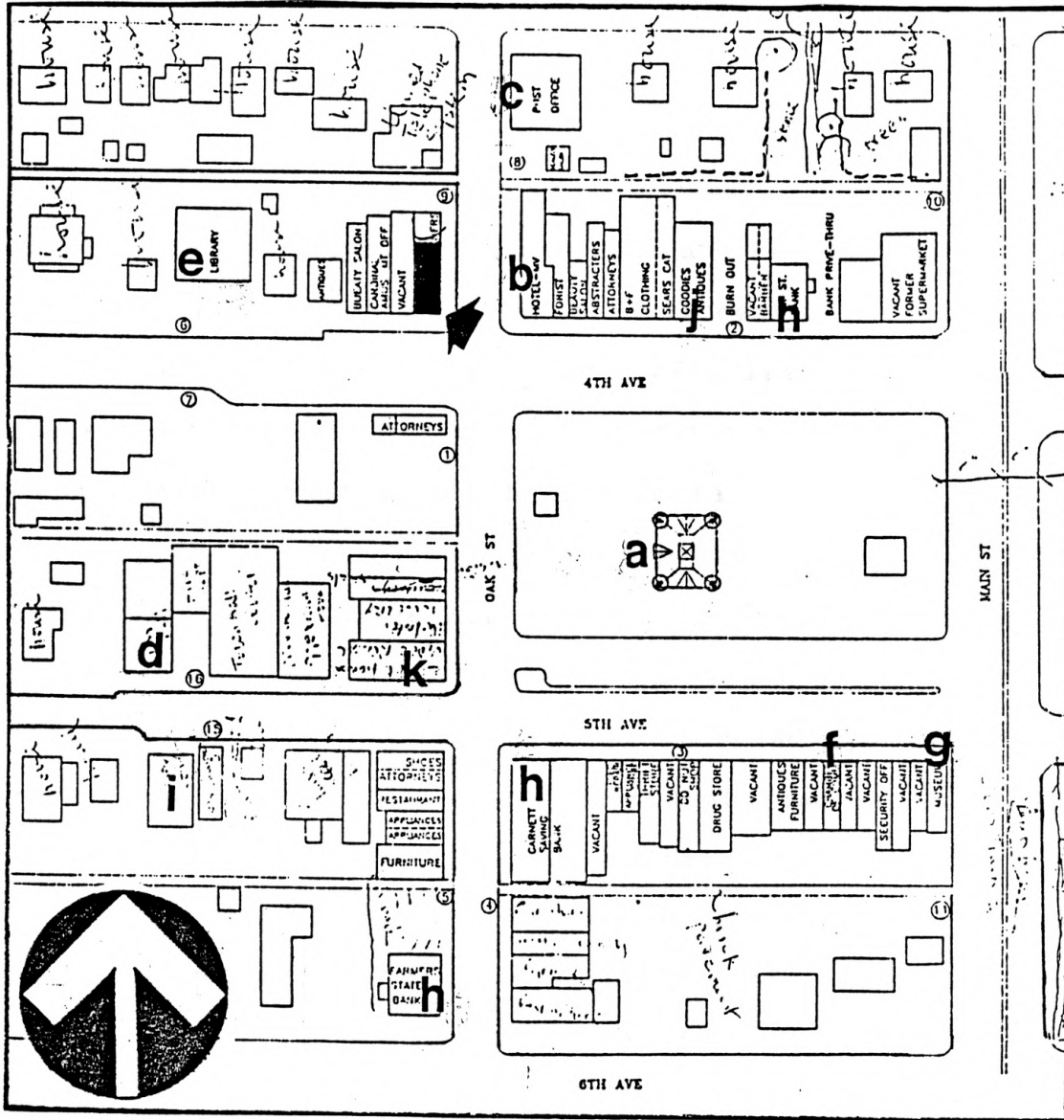

Map <2>

Downtown Garnett and Location of the IOOF Hall

Source: Ray B. Weisenburger

- | | |
|------------------------------------|------------------------|
| Legend: a. Courthouse | b. Fourth Avenue Hotel |
| c. Post Office | d. City Hall |
| e. Library | f. Chamber of Commerce |
| g. Museum | h. Banks |
| i. Senior Center | j. Goodies Antiques |
| k. D.W. Childs Realty Co. Building | |

Another big question is: what might the community need in the downtown area - housing, more shops, a museum, a place with tourist appeal, or a cultural and recreational center ? The author presented the question to the local Chamber of Commerce, the city government, and several downtown shoppers. They seemed to be in favor of the last option - a cultural and recreational center. Yet, how might a cultural and recreational center be perceived by the community? What are the desired facilities ? In order to answer these questions, the author conducted a community need survey which is discussed in detail in Chapter Three.

Chapter Six and Chapter Seven explore how the adaptation might serve the new use. The author puts the emphasis on the interior space and an addition and decides to make the least alteration of the exterior. This design strategy is based upon a precedent and situational study. Since this thesis started in early 1991, and completed by the end of 1991, it has based upon the 1989 version of Uniform Building Code (UBC) for design considerations. In addition, this thesis has drawn reference to the Title III of Americans with Disabilities Act (ADA), which signed by President Bush in July 1990, for concerns of making the building a barrier-free environment.

After all, this thesis is an architectural study with design considerations, and does not address economic factors which are always associated with adaptive-use projects. The nature of the project is hypothetical since the community has no development plans for the building. Yet, as will be described in the thesis,

the community has already shown concerns for renovating this building. It was a building which initiated the attempt of "painting the buildings in downtown" a few years ago.³ Both the Garnett Chamber of Commerce and the Anderson County Economic Development Committee have shown their interests in the project and are willing to support it by any means possible.

³. In 1985, some local residents advocated to "paint the downtown". They started with the IOOF Hall. Unfortunately, no real painting work has been done to this building yet.

Part One: Program Study

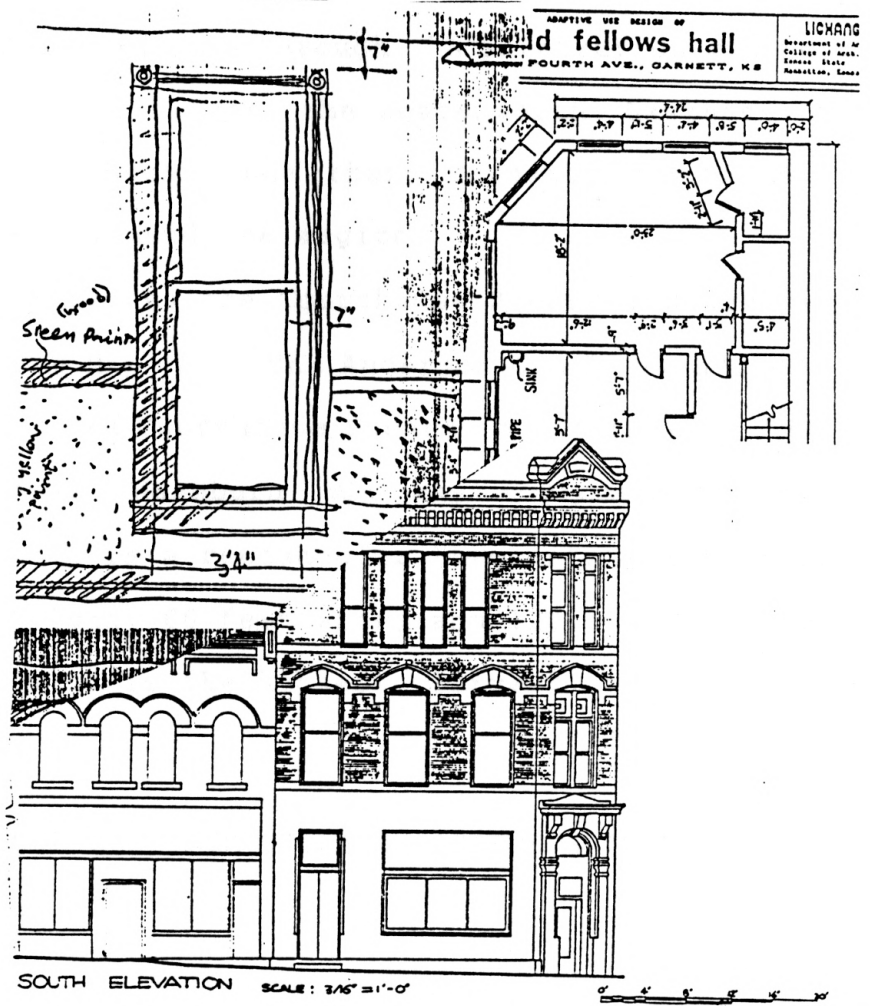

Chapter 1

BACKGROUND OF THE IOOF HALL

<1> Historic Downtown Garnett and the IOOF Hall

Garnett was founded in 1857. Dr. George Cooper helped survey land in Anderson county and organized a town company in Louisville, Kentucky, to bring settlers to the new town. The town was named for Mr. Garnett, a wealthy Louisville bank president who had financed the settlers. The town companies of Troy (north of Garnett) and Garnett were consolidated in December 1857 under the title, Town of Garnett. In 1859, Garnett was made the county seat. On October 7, 1861, Garnett became a municipal corporation, the same year Kansas was admitted as a state. Garnett was basically an agricultural community before the railroad came through. "A celebration was held March 3, 1870, for the new railroad, the Leavenworth, Lawrence and Galveston (Santa Fe)."⁴ Ever since then, Garnett has become a focal point for business around the region.

Downtown Garnett includes the Courthouse Square and the five block area around it (see Map <2>). The Anderson County Courthouse, located at the center of the Courthouse Square, built in 1901-1902, was designed by George P. Washburn, who was a prominent Kansas architect at the time. It is a rectangular three-story structure, approximately 102 feet long, 66 feet wide, and 120 feet from roof to ground. Up until now it is the highest, largest, and the most

⁴. Gilma Rogers, OUR HERITAGE IN EARLY ANDERSON COUNTY, pp. 7

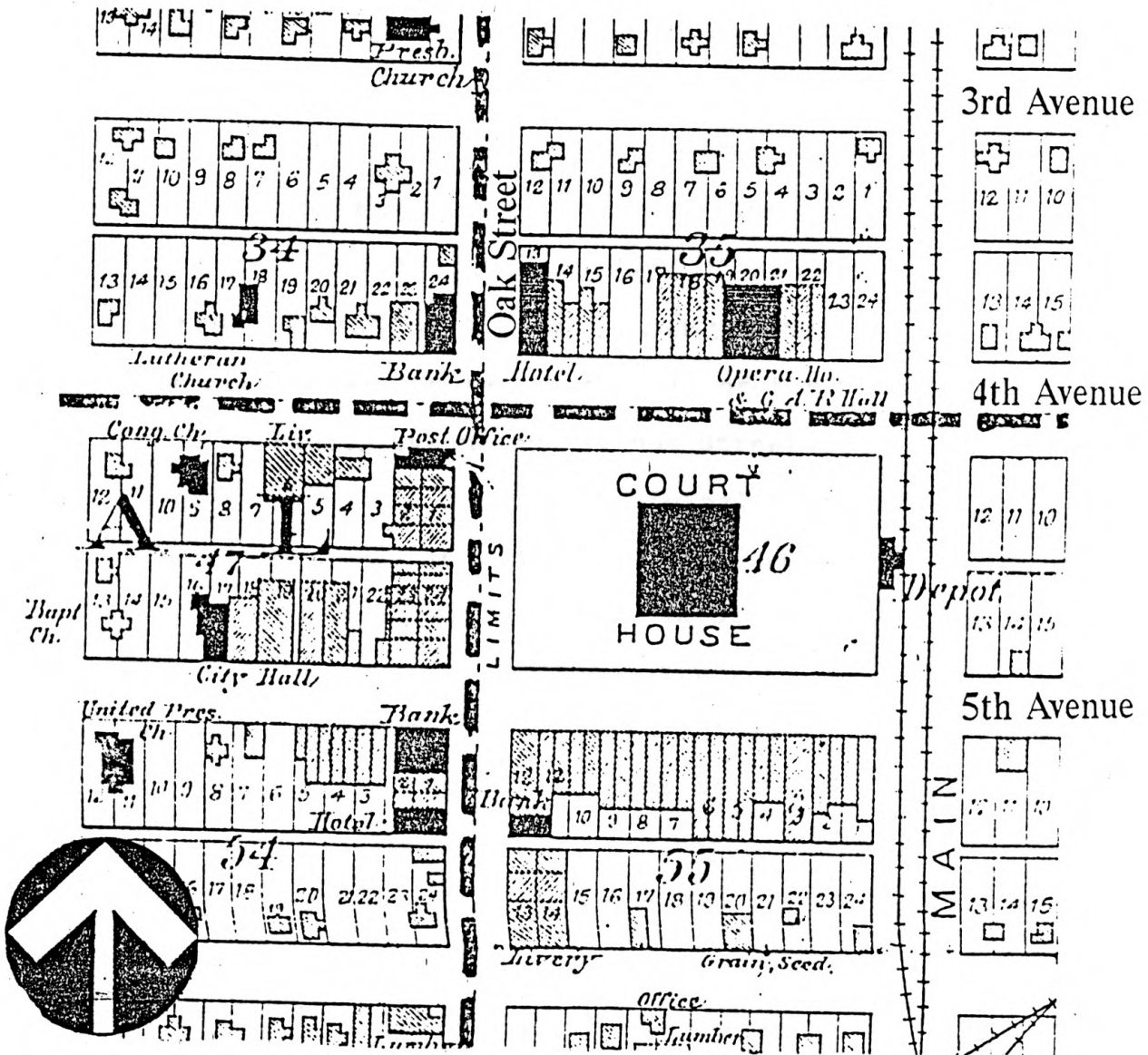

Map <3>

Downtown Garnett in 1901

Source: Garnett City Library

important building in the downtown area (see photo 1-1). Many of the brick buildings around the Square were erected in the late Victorian period. According to Gilma Rogers's book, OUR HERITAGE IN EARLY ANDERSON COUNTY, published by the Anderson County Historic Society, most of these buildings had similar windows and intricate trims at the roof line⁵. To the north of the Square, Fourth Avenue runs from west to east. It is an important street with a history that dates from the territorial days of Kansas, and along which many of the "firsts" of Anderson County have occurred.⁶ In 1858, Garnett's first frame house, later part of the hotel, was built on the corner of Fourth Avenue and Walnut Street. The Lutheran Church next to it was built in 1891. The original Fourth Avenue Hotel was built in 1884, one year after the IOOF Hall was built, and is located opposite the IOOF Hall, on Oak Street. It is vacant today (see photo 1-2). Another important structure on Fourth Avenue was the Garnett Opera House which was originally known as the Grand Army Hall. Built in 1884 by veterans of the Civil War, it was a two-story building with its top floor being the opera hall, and the first floor being used for stores. It served as a community center for forty years before it was destroyed by fire in 1924. Activities taking place were high school and grade school exercises, home talent shows, traveling shows, dances and basketball games

⁵. Gilma Rogers, pp. 16.

⁶. Gilma Rogers, OUR HERITAGE IN EARLY ANDERSON COUNTY, pp. 16



Photo 1-1

Anderson County Courthouse

Source: City of Garnett

Date: Summer 1990



Photo 1-2

Fourth Avenue Hotel

(Photo taken in May 1991 by Lichang Jin)

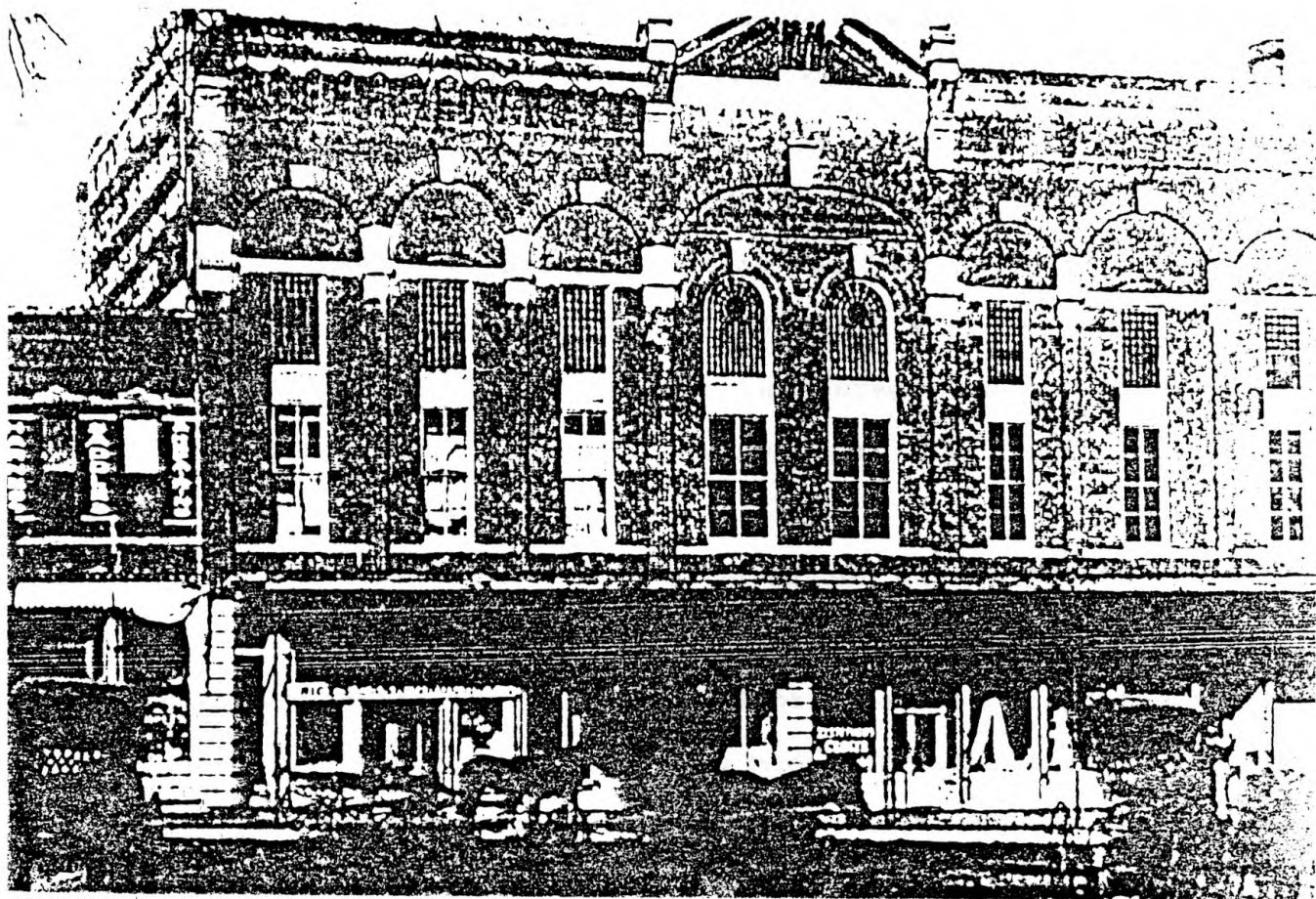

Photo 1-3

Garnett Opera House (Former Grand Army Hall)

Source: Anderson County Museum (Photo taken in early 1920s, the building was destroyed by fire in 1924)

(see photo 1-3)⁷.

An old downtown map of 1901 showed clearly an image of the historic downtown Garnett (see map <3>)⁸. Reading from the map, we know that there was one post office, one hotel and two banks on Oak Street, which runs from north to south, and a railway depot on Main Street. The following photographs show visually the historic downtown. Photo 1-5 was taken around 1900. The parade took place on Oak Street and Main Street, to the west side of the Square. We can see the IOOF Hall was the building at the upper right corner. The next photo (see photo 1-6) taken about the same period shows a group of Civil War veterans in front of the IOOF building. Another photo taken about 1903 (see photo 1-7) shows a closer view of the IOOF Hall with an early day taxi in the foreground.

As recorded in the local newspapers, the IOOF Hall was completed in early 1884.

"... The new bank building on the corner of 4th Avenue and Oak Street is now very rapidly approximating completion. It is beyond question one of the finest brick and stone edifice ever erected in the county, and as a model of architecture, finish and fine work, we question very much if it can be excelled in any town in Southern Kansas; in fact it would be a credit to

⁷. The Anderson County Historic Society, ANDERSON COUNTY HISTORY, ADDENDA, pp. 19.

⁸. Source: PLATE BOOK OF ANDERSON COUNTY, KANSAS, compiled from county records and actual surveys, published by the Northwest Publishing Co., Minneapolis, Minn., 1901.

WEST SIDE OF SQUARE
GARNETT KANS.

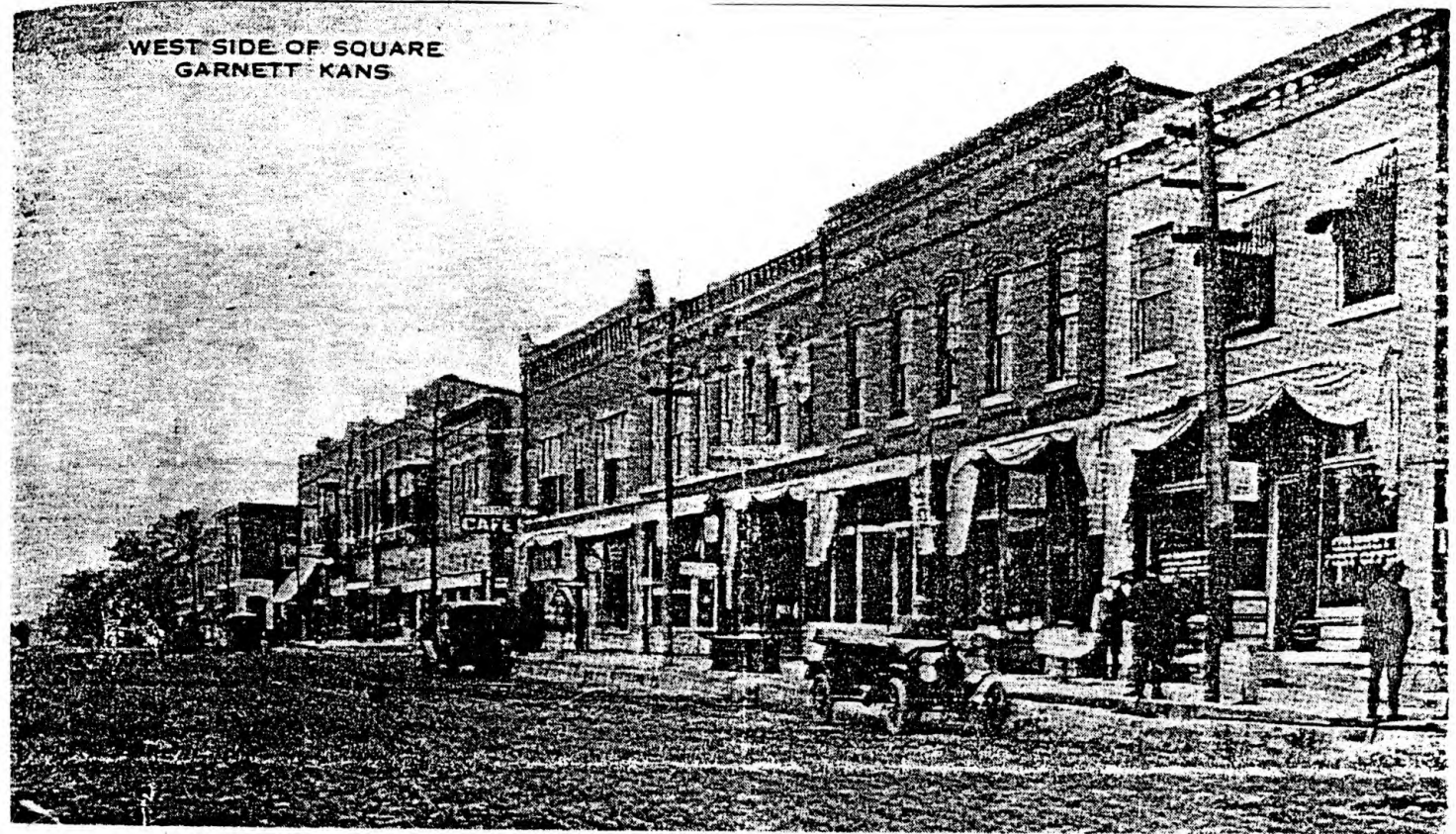

Photo 1-4

Downtown Garnett in 1917 (Old Oak Street Looking Northwest)

Source: Anderson County Historic Society

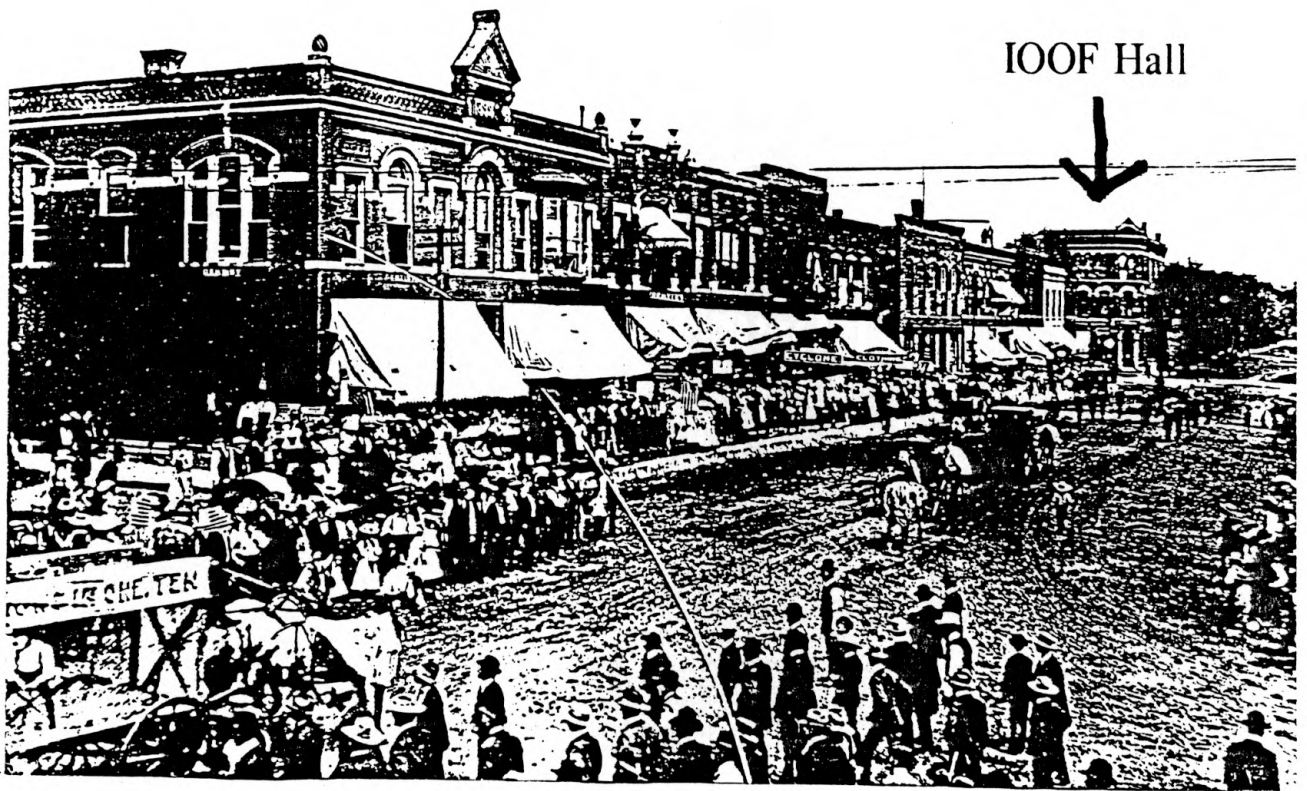

Photo 1-5

Downtown Garnett in 1900s (Old Oak Street Looking North)

Source: Anderson County Historic Society

IOOF Hall

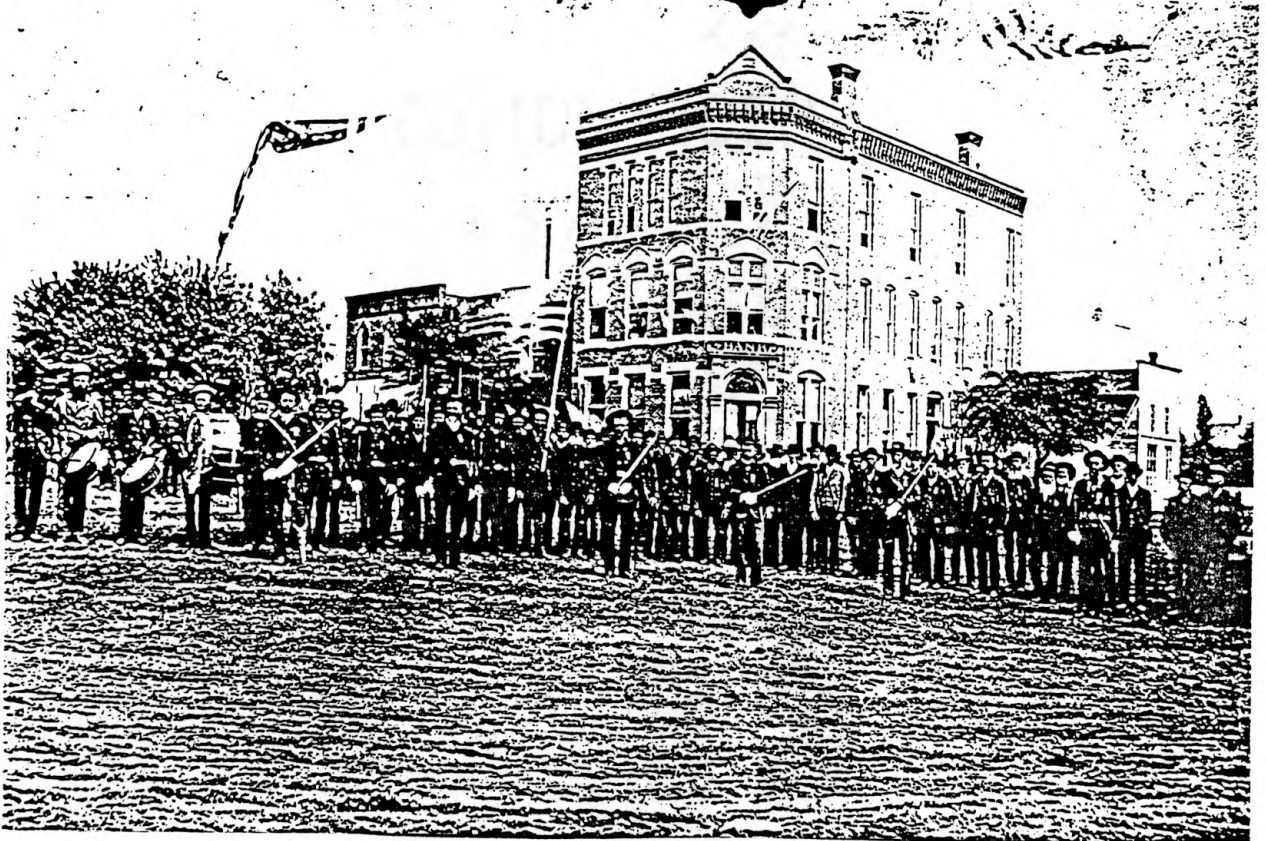

Photo 1-6 Downtown Garnett in 1900s (North-West Corner of Square)
Source: Anderson County Historic Society

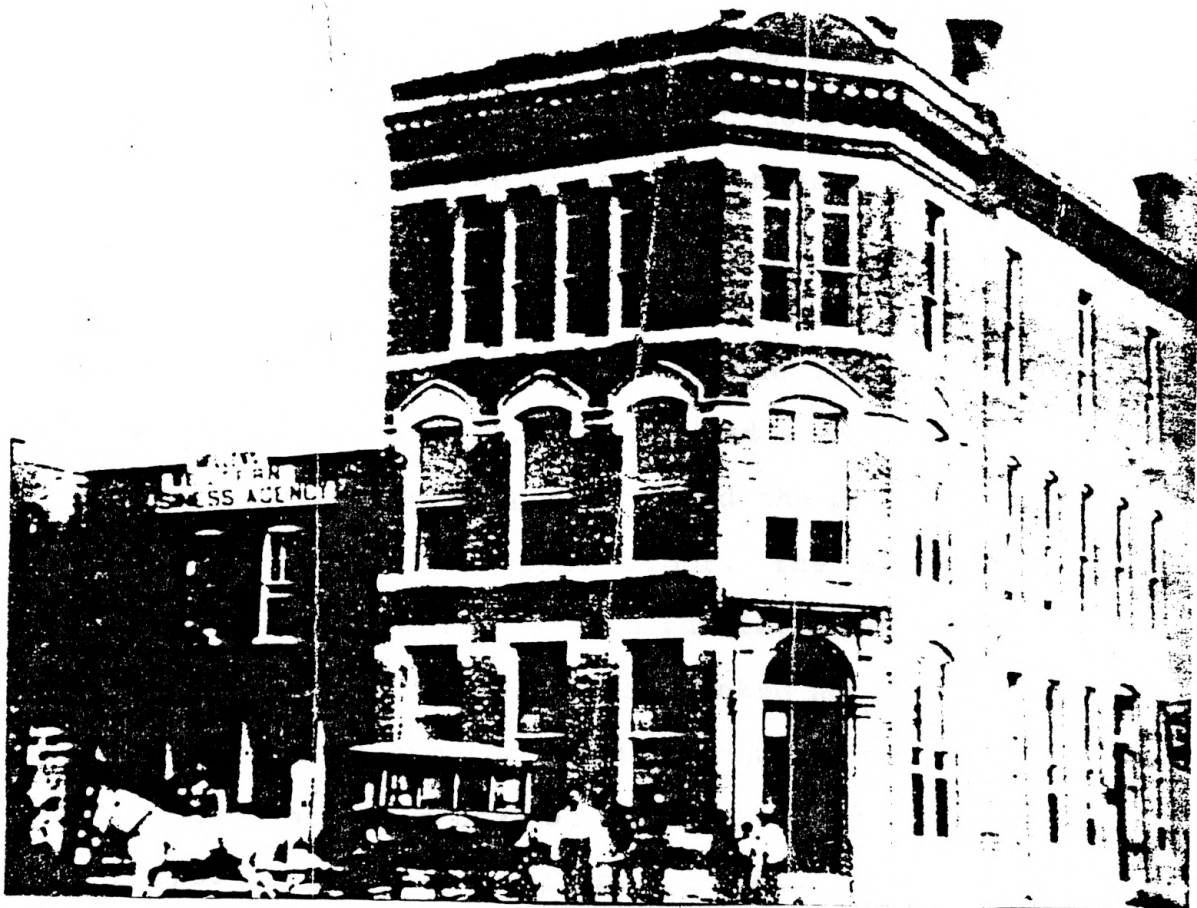

Photo 1-7 Downtown Garnett in 1903 (The IOOF Hall)

Source: Anderson County Historic Society

4th street in St. Louis ..." (The Garnett Journal, December 8, 1883).

"... S. Kauffman and J. A. Patterson & Co. have completed the fine new brick and stone building, occupied by the Bank of Garnett and various other offices. Its dimensions are 30 x 70, three stories in height, and Mr. Kauffman gives its cost as \$13,000. It is the finest business building in Garnett at present. The third floor is about to be occupied as a lodge room by our secret societies." (Anderson County Republican, May 16, 1884).

As shown in the old photographs, the IOOF Hall was a three-story brick and stone structure. It had a subtle style of Gothic Revival with its window proportions and the pointed arched lintels on the windows on the second floor. The exterior walls were constructed with red brick laid in running bond with white mortar. The lintels on the second floor are linked horizontally by a stone belt and carved in a similar fashion with the lintels. In plan, its rectangular shape was broken at the south-east corner which is cut off to provide the main entrance to the first floor. The old photographs suggest that the windows on the first floor were similar to the ones on the second floor in both location and proportion. These windows have been altered to different shapes at present. Chapter two will address other changes in detail.

<2> The IOOF and the IOOF Hall

The IOOF, *Independent Order of Odd Fellows*, is a fraternal organization brought to the United States by Thomas Wiley from England in 1817⁹. It is one of those "secret societies" that were very active from the late nineteenth to the mid-twentieth century. Odd Fellowship, often referred to as "the poor man's Masonry"¹⁰, in many ways resembles Masonry. It taught its members secret passwords, signs, and grips; it hoodwinks (blindfolds) the candidate during initiation; it votes by ball ballot when admitting the candidate; it requires belief in a supreme being; it accents certain moral lessons in its ritual¹¹. The Odd Fellows confer three decrees in addition to the initiatory degree. These are known as Friendship, Love, and Truth, symbolized by three chain links joined together (see figure 1-1). The three links are the official emblem of the IOOF. The letters F, L, T are illustrated in the three links, one letter per link. These symbols and the symbols associated with the initiatory decree like the Eye, Skull and Cross-Bones, Scythe, Globe, and Ark, etc., are found in the interior decoration (ie., the mural on the wall) on the third floor of the IOOF Hall in Garnett.

⁹. Evidence show that Thomas Wiley was the first person who brought into the United States the Order of Odd Fellows in 1817. Later in 1843, the White Odd Fellows started calling themselves the Independent Order of Odd Fellows while the Black Odd Fellows were called the Grand United Order of Odd Fellows, G.U.O.O.F. (see Advin J. Schmidt's book *FRATERNAL ORGANIZATIONS*, pp. 243).

¹⁰. Free Masonry was another popular fraternal organization at the time.

¹¹. Schmidt, Advin J. , *Fraternal Organizations*, 1980, pp. 244.

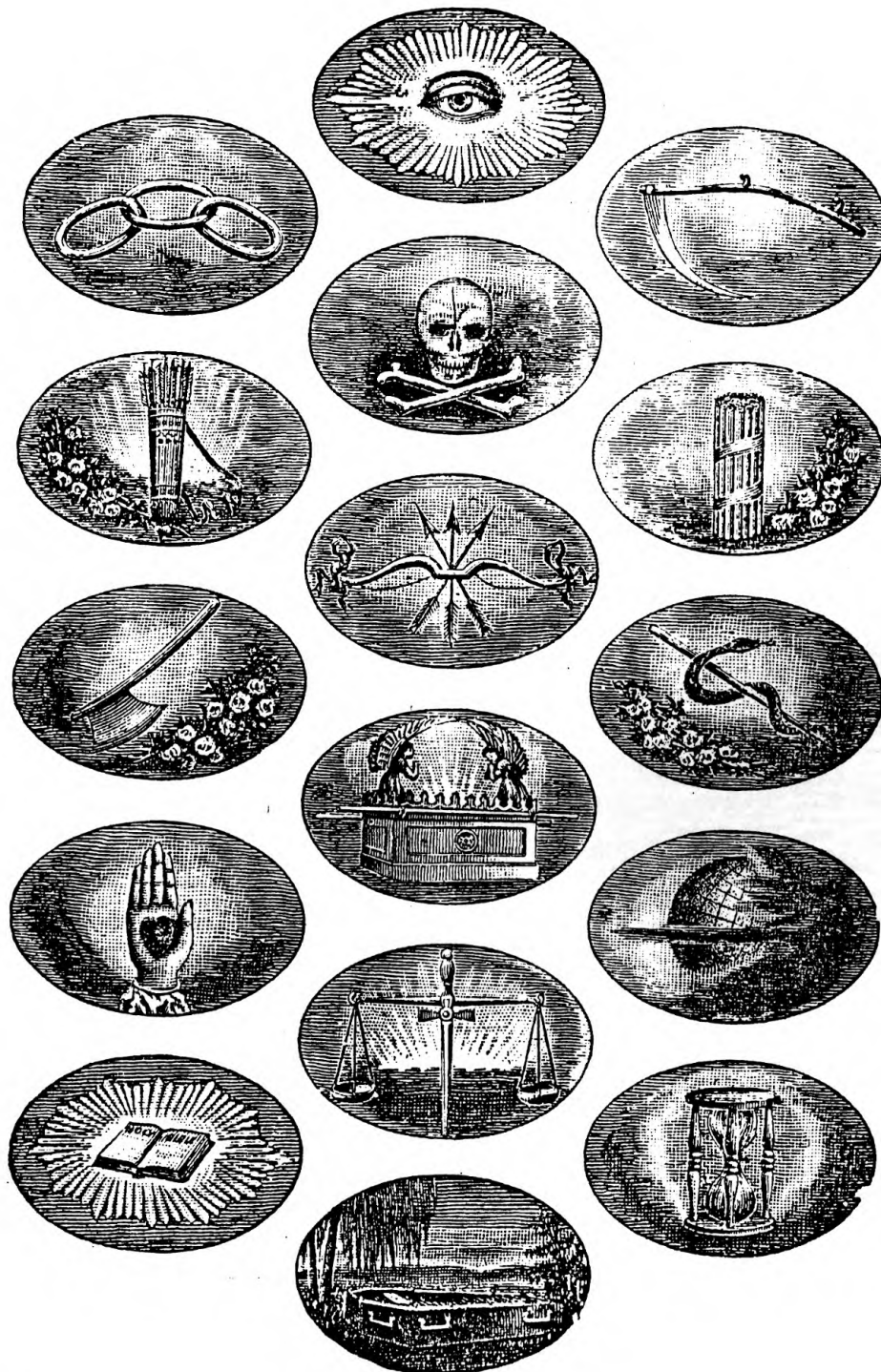

Figure 1-1 Symbols of The IOOF

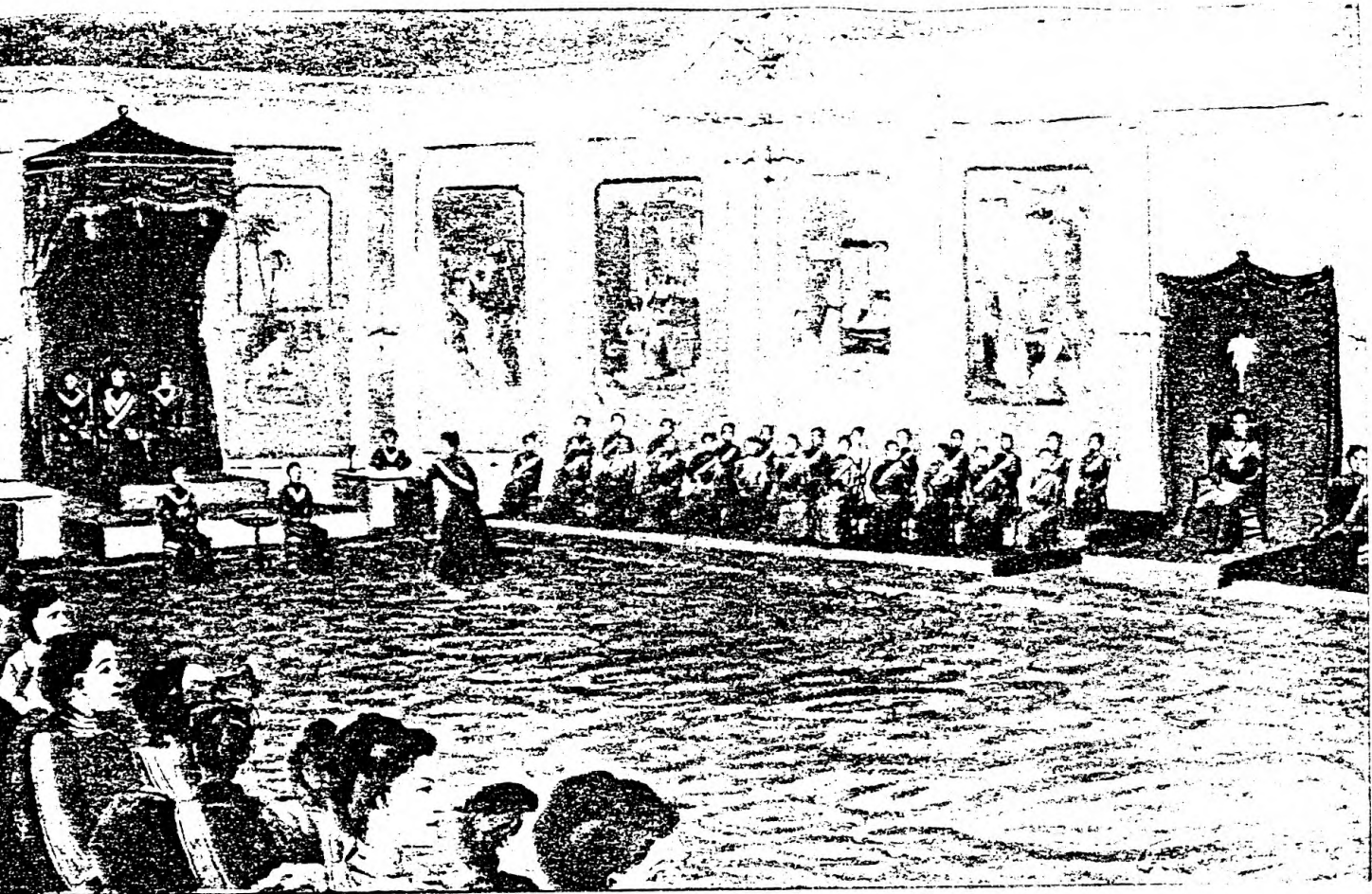

Figure 1-2 An IOOF Meeting Scene

It is interesting to note that the IOOF has also a female order, called the Rebekah Assemblies, which was organized in 1851¹². Figure 1-2 was a painting depicting a formal meeting of this organization from which we can read its interior decoration and furniture arrangement¹³. The interior of the third floor of the IOOF Hall in Garnett resembles in many ways this painting (see photo 2-32 to 2-36). This grand meeting room has a stage-like space at both axial ends with floors rising up one step. The two longitudinal stages are larger where higher rank members were seated. There are chairs against four walls enclosing the central space where ceremonies and lengthy rituals took place. There is only one narrow staircase leading up from the second floor. The door connecting the meeting room and the stairs had a flip-covered hole through which a member's identity was checked before letting him in.

In its early age, the IOOF did not have a formal place for lodge activities. Meetings were sometimes held at a tavern where the landlord might be a host¹⁴. Later, when the organization expanded they started to build their permanent lodge, called the "Odd Fellows Home". Figure 1-3 shows some of these buildings that were exclusively built for the organization¹⁵. These grand

¹². Schmidt, Alvin J., 1980, pp. 245.

¹³. Source: Ross, Theodore A., THE ILLUSTRATE HISTORY OF ODD FELLOWSHIP, The Ross History Co., New York, 1913

¹⁴. Ross, Theodore A., 1913, pp. 406.

¹⁵. Source: Ross, Theodore A., 1913

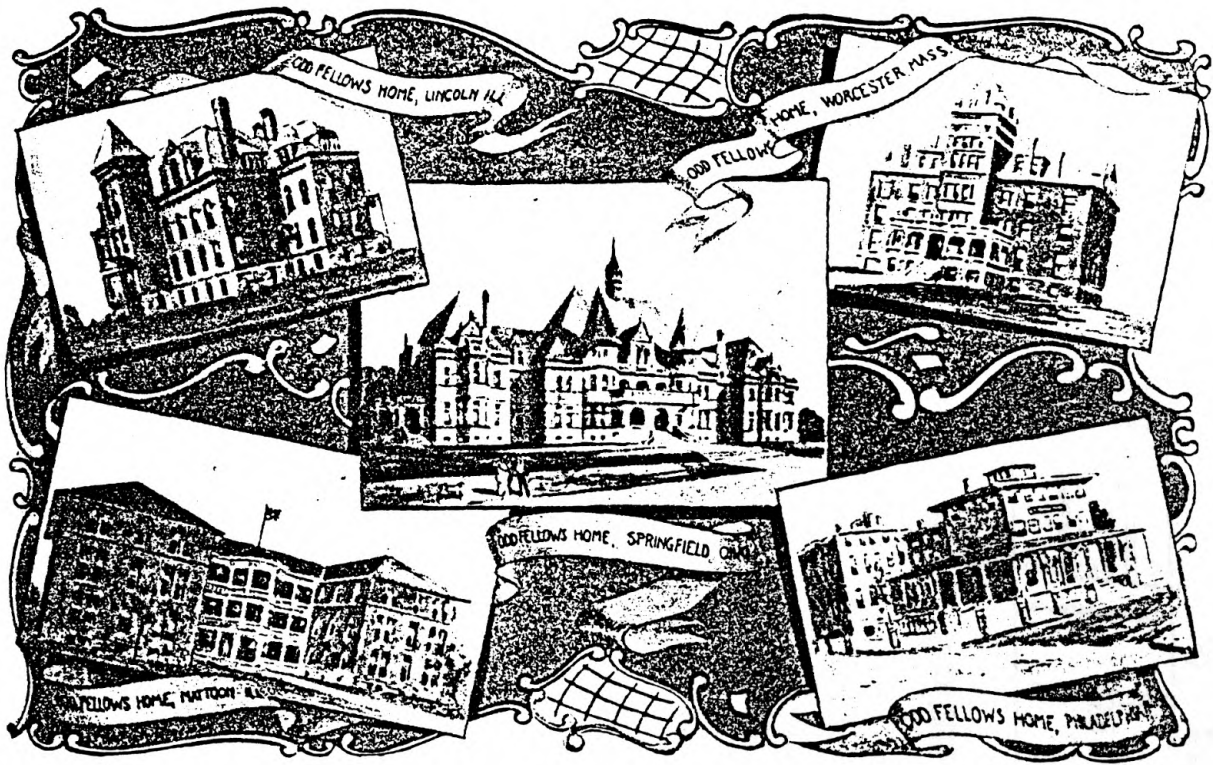

Figure 1-3 Odd Fellows Homes

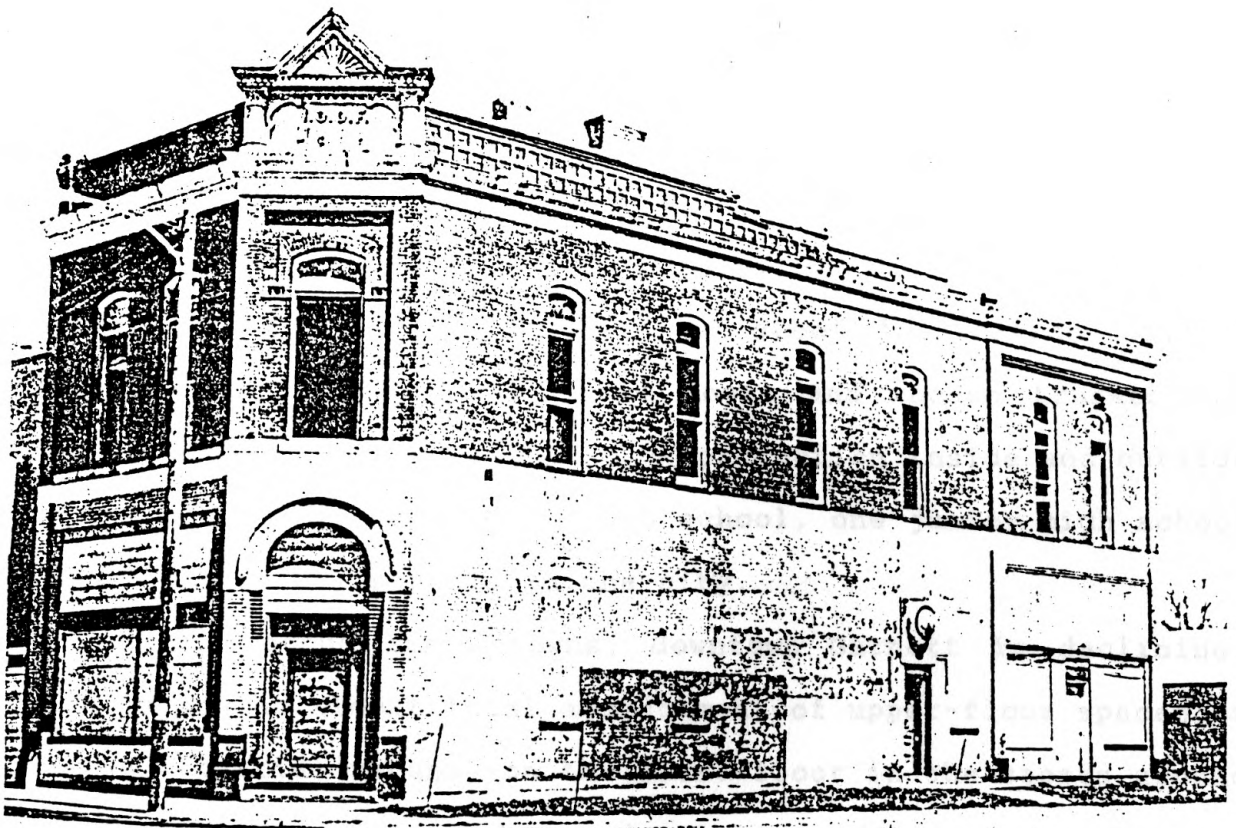

Photo 1-8

The Former IOOF Hall in La Cygne

Source: Robert Cugno (Photo taken in October 1989)

buildings were mostly in large cities. In small towns, however, they normally occupied part of a building, on top floor(s) in most cases. Photo 1-8 shows an example where the IOOF occupied its second floor. In a situation like this, the buildings they occupied cannot be called a building type.

<3> Present Garnett and its Downtown

The current population of Garnett is a little over 3,000¹⁶. The city has a mixed economic base. On the one hand, there are farms to provide both livestock and crops; on the other hand, there are industrial developments such as steel fabrication, church furniture manufacturing, aluminum doors and wooden trusses and fiber-glass reinforced plastic tank production inside and outside the city. There is one senior high school, one junior high school and two elementary schools in the city.

Like numerous small towns, downtown Garnett is declining. There is now an almost total abandonment of upper-floor spaces as well as a partial vacancy on the first-floor in the stores around the Square. Not many people go downtown to do shopping. The new commercial strip in the western part of the city attracts more and more business. The downtown is left with a few antique stores and small retail shops. To revitalize the downtown means to bring people back. Downtown Garnett should strive to become a focal point for the whole community again (see map <2>).

¹⁶. In 1989, the figure is 3,030. Source: KANSAS COMMUNITY FILE: GARNETT, Farrel Library Documents, Kansas State University, June 1990

Today, the Courthouse is listed on the National Register of Historic Places (see photo 1-9). Its third-floor courtroom was restored in 1978 and features stained glass, the work of a local artisan, which are exact replicas of the original windows. Fourth Avenue, a well landscaped, wide, median-separated two-lane street, has been carefully designed as a main route from the highway to the downtown business area. This street is still lit by the original ornamental light fixtures that, in the early days, gave it the name of "the White Way" (see photo 1-10). Important buildings and facilities on Fourth Avenue within the downtown area are: the Garnett Public Library, Harris House, built in 1888 (another Garnett building which is on the National Register of Historic Places, see photo 1-11), Kansas State Bank, and the well known Goodies Antiques Store. There are two other bank buildings, Garnett Savings Bank and Farmers State Bank, and a Post Office on Oak Street. It is worth mentioning that the D. W. Childs Realty Co. building at the corner of Oak Street and Fifth Avenue has been recently painted as a guideline for the future restoration of the town square (see photo 1-12). The renovation work also included the replacement of materials such as wood panels on the shopfront on the first floor, and window glass. According to the Chamber of Commerce, it was a pure community self-help project, no resources coming from the outside. The project was nicely done and everyone participating enjoyed it. On Fifth Avenue important facilities include the City Office and City Hall of Garnett, the Senior Center, Anderson County Historic Museum and the Chamber of Commerce

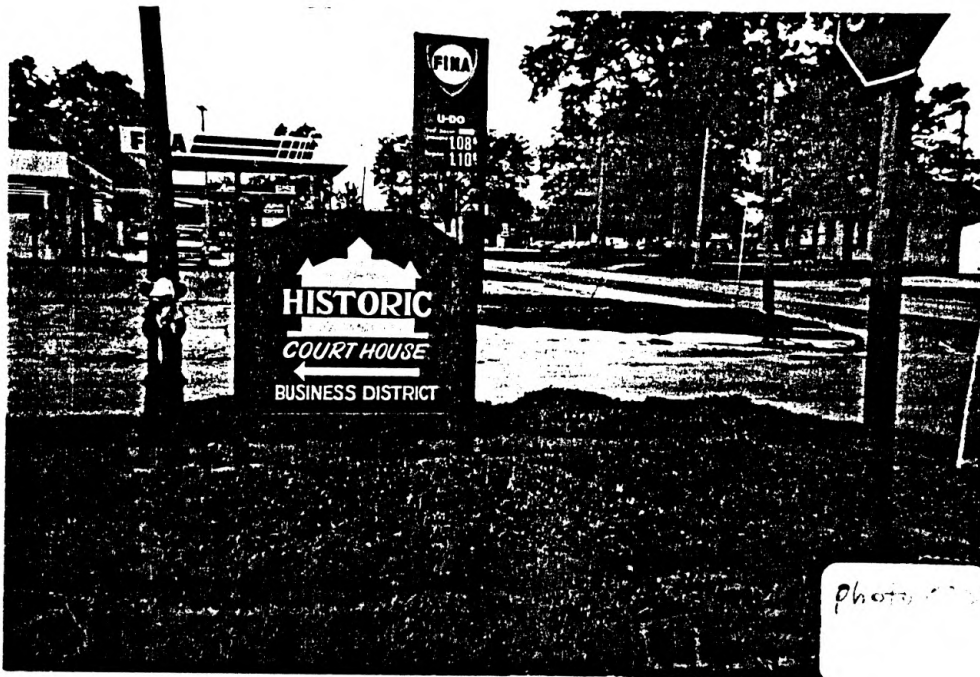

Photo 1-9

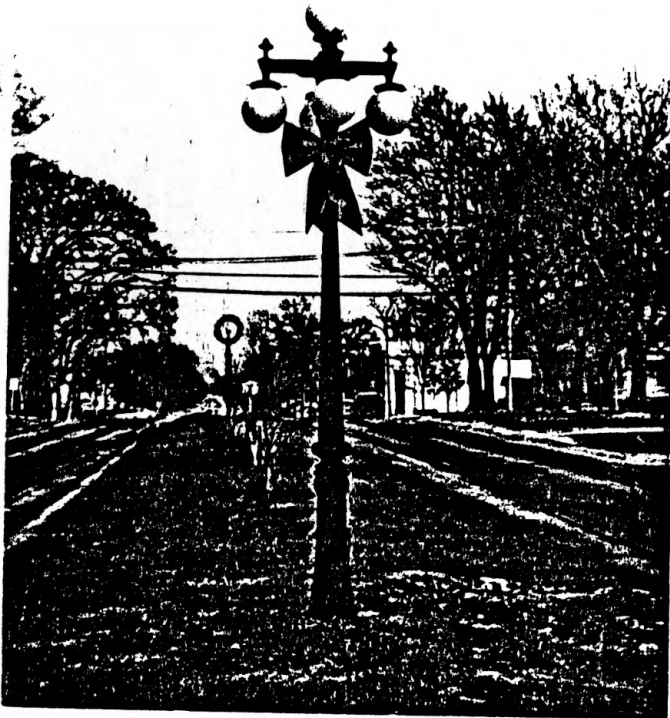

Photo 1-9 (above) The Intersection of Highway US-59 and 4th Avenue

Photo 1-10 (below) 4th Avenue Looking Towards Downtown

(Photos taken in May 1991 by Lichang Jin)

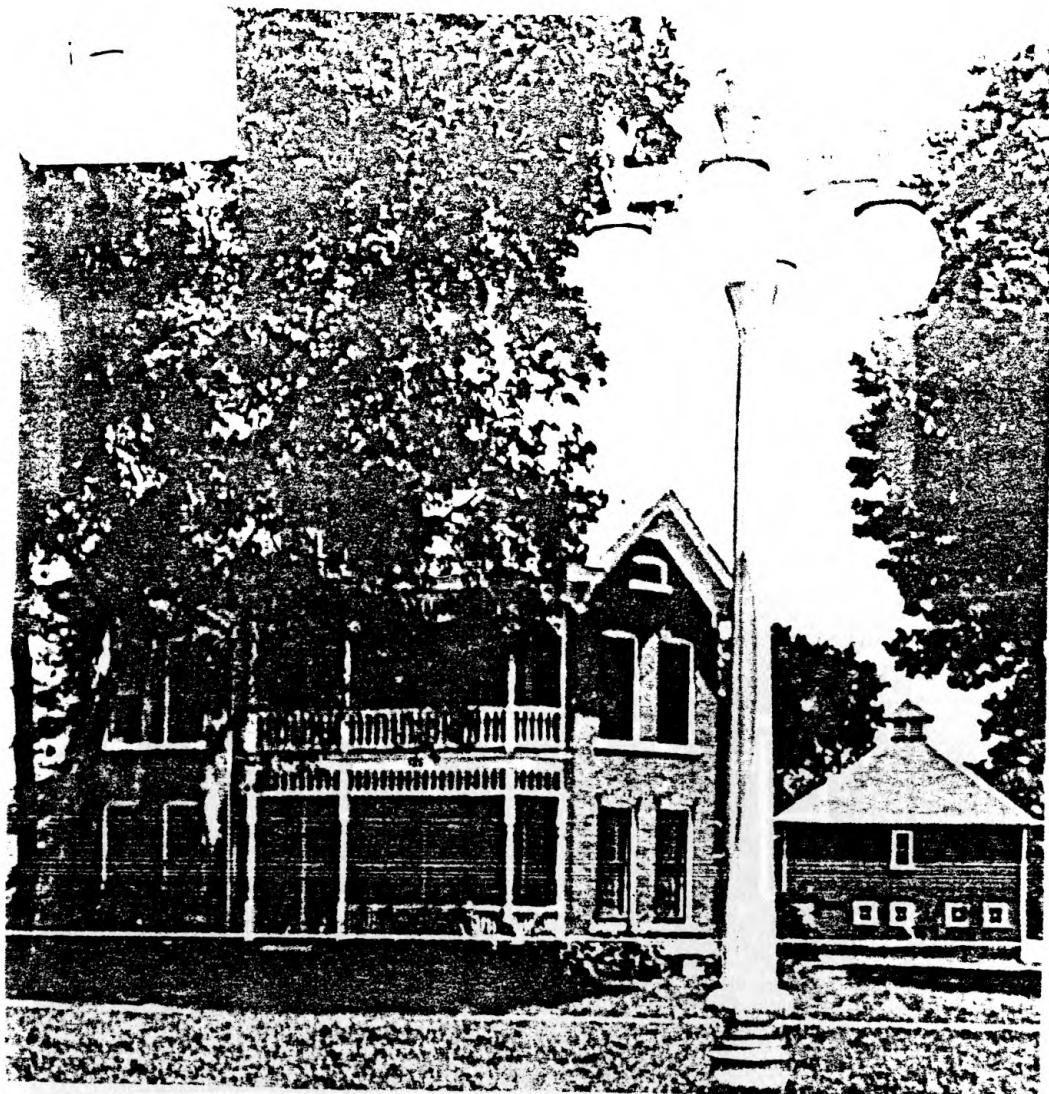

Photo 1-11 The Harris House on 4th Avenue

Source: City of Garnett

(Photo taken in May 1989, the building has been renovated for tourists to visit)



Photo 1-12

The D.W. Childs Realty Co. Building on Oak Street

(Photo taken in May 1991 by Lichang Jin)

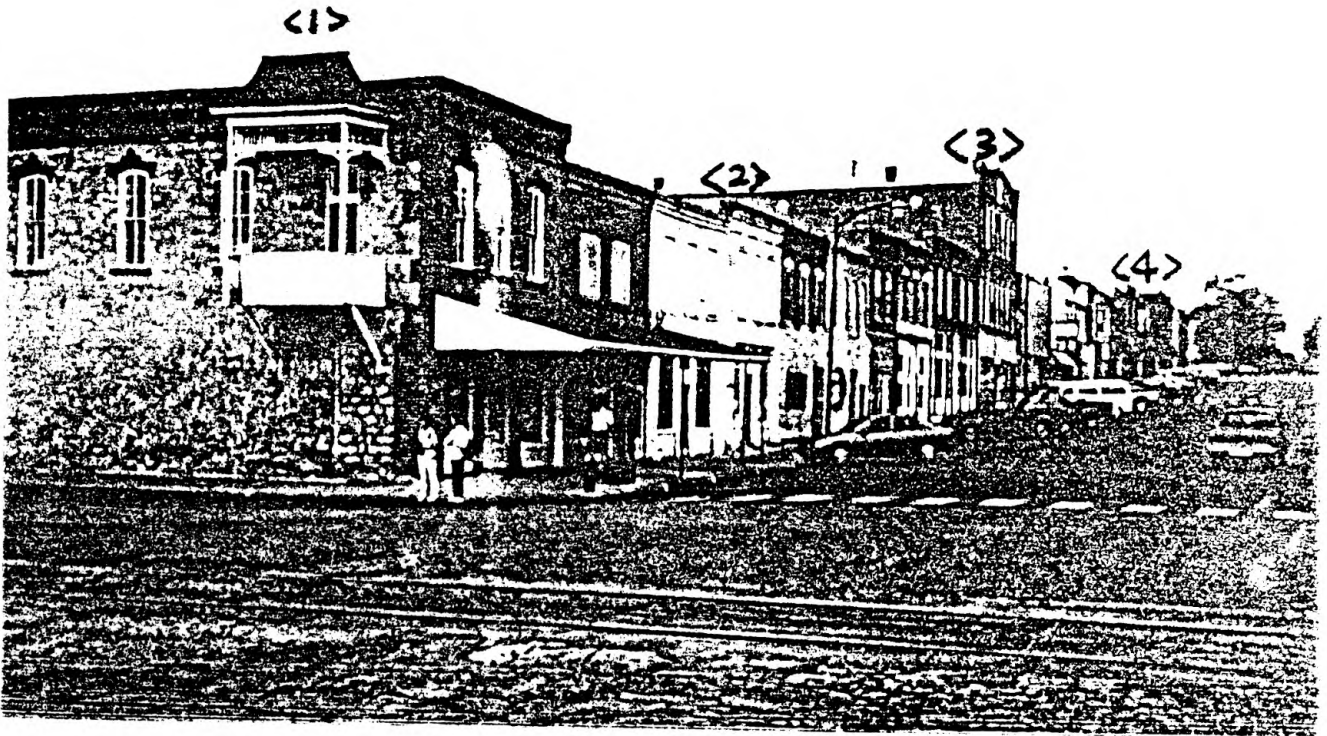

Photo 1-13 Fifth Avenue Looking West

- Legend:
1. County History Museum
 2. Chamber of Commerce Office
 3. The Masonic Hall
 4. Garnett Savings Bank

(Photo taken in January 1991 by Lichang Jin)



Photo 1-14, 1-15 The 1991 Annual AAUW Square Fair
(Photos taken in May 1991 by Lichang Jin)

(see photo 1-13). Compared with Oak Street and Fourth Avenue, Fifth Avenue has the most continuous streetscape, there is no burnt-out lot.

There are several activities held in the downtown area seasonally or annually. These activities are helpful to the promotion of downtown revitalization, especially the A.A.U.W. Square Fair¹⁷ which attracts throngs of visitors from the county to the Courthouse Square and the whole downtown area (see photo 1-14, 1-15).

Commercial District
measured drawing (figure 2-1) checklist,
photo 2-1 to 2-6).

of the 100F Hall in Garnett, Kansas
Fourth Avenue and Oak Street, Garnett, Kansas.
frontage on Oak Street, 21-foot frontage on
Commercial District:
along Fourth Avenue and Oak Street.
Main Street, Garnett, Kansas for the 100F Hall

17. "A.A.U.W." stands for the American Association of University Women. The Fair, initiated by the local branch of the Association, is an arts and crafts festival held in May, always the Saturday before Mother's Day. It is an all-out community event which has also a far-reaching appeal to the surrounding regions.

Chapter 2

EXISTING CONDITIONS OF THE IOOF HALL

This chapter presents an architectural survey of the existing condition of the IOOF Hall. The survey was conducted during January 2-5, and May 14-15, 1991. The methods used are photographing, sketching, hand-measurement, and checklist recording. No original documents (ie., construction drawings and bidding documents) were available.

<1> Site Condition and General Data

Survey methods are measured drawing (figure 2-1), checklist, and photographs (photo 2-1 to 2-6).

Checklist 2-1

General data about the IOOF Hall in Garnett, Kansas

- * Location: Lot-24 Block-34, Fourth Avenue and Oak Street, Garnett, Kansas.
- * Site Area: 0.049 acre; 71-foot frontage on Oak Street, 31-foot frontage on Fourth Avenue.
- * Zoning: C-2 Central Commercial District.
- * Parking: 4 spaces (parallel), along Fourth Avenue and Oak Street.
- * Occupancy: First floor - Pat Winfrey Real Estate (at the north-east corner).
Second floor - vacant.
Third floor - vacant.
- * Gross Floor Area: 6,580 sq ft.

The IOOF Hall is neighbored by a two-story building to its west, and by a one-story building to its north, which is also owned by the IOOF lodge and houses the Crystal Cleaners. The two-story building to the west of the IOOF Hall is also a one-story shed,

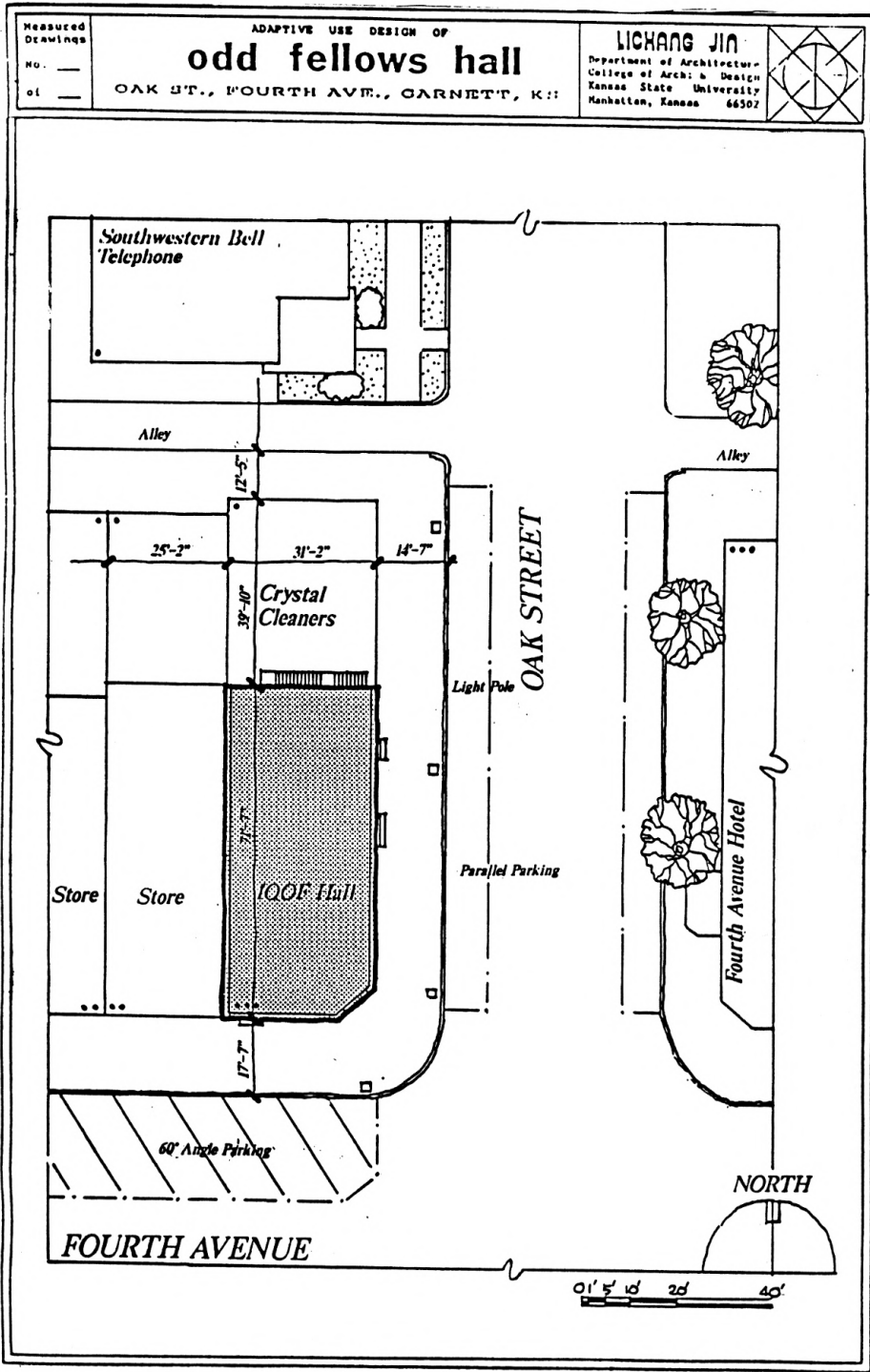

Figure 2-1 Measured Existing Site Plan
 (By Lichang Jin in May 1991)

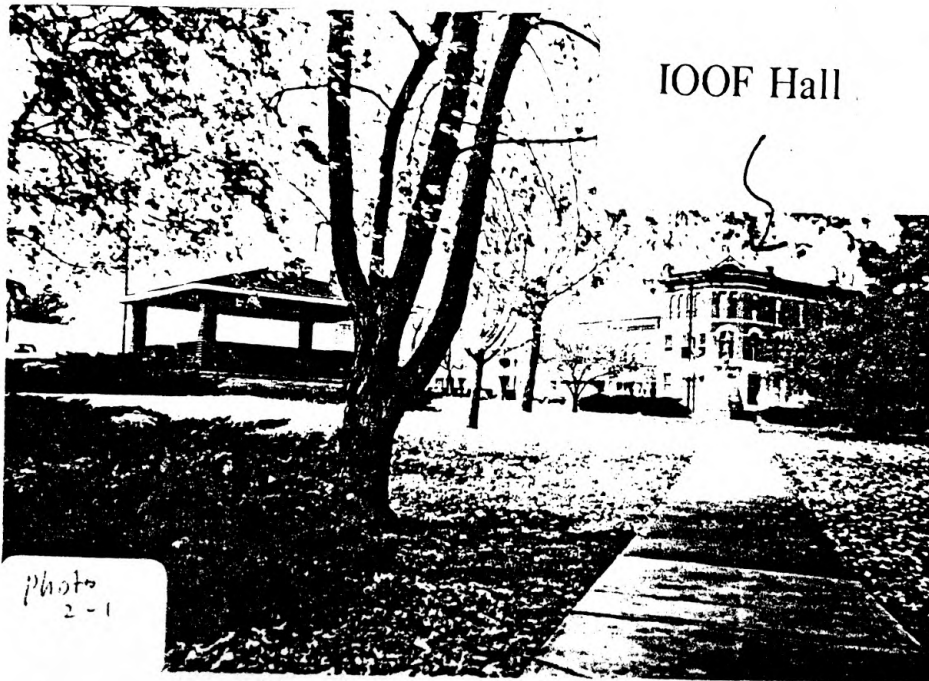

Photo 2-1 (above) The IOOF Hall Looking From The Courthouse
Photo 2-2 (below) The IOOF Hall Looking From Main Street

(Photos taken in January 1991 by Lichang Jin)

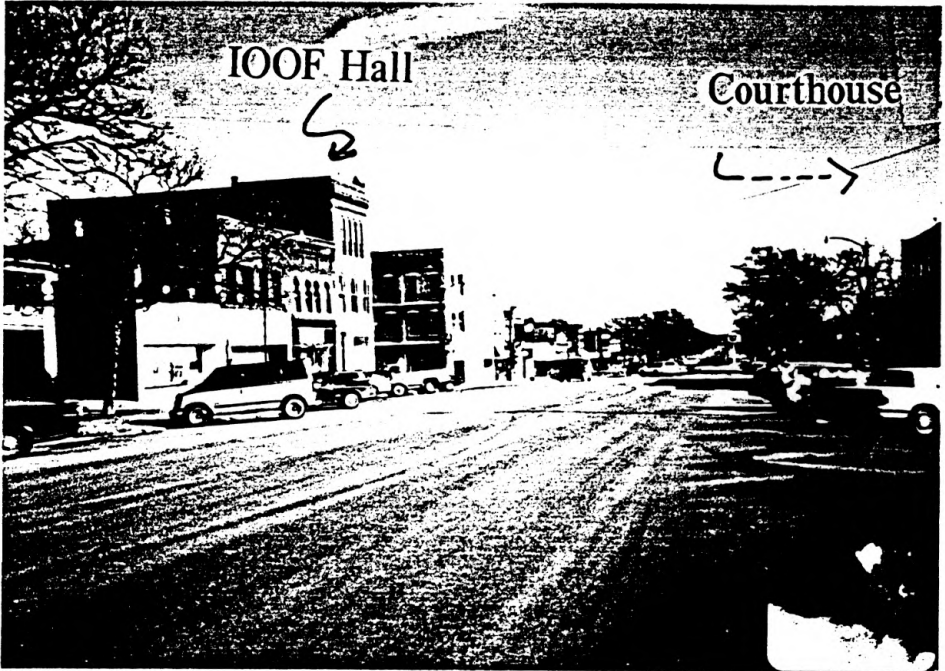

Photo 2-3 (above) The IOOF Hall, 4th Avenue Looking East
Photo 2-4 (below) The IOOF Hall, Oak Street Looking North

(Photos taken in May 1991 by Lichang Jin)

4th Avenue Hotel

IOOF Hall



photo
2-6



Photo 2-5 (above) The IOOF Hall, Oak Street Looking South
Photo 2-6 (below) The IOOF Hall and Adjoined Neighboring Buildings

(Photos taken in January 1991 by Lichang Jin)



photo
2-7



photo
2-8

Photo 2-7, 2-8
The IOOF Hall and Adjoined Neighboring Buildings (back view)

(Photos taken in January 1991 by Lichang Jin)

used as garages and storage, extended to its north and adjoined with the Cleaners building. The view of these buildings from the back-alley is disorganized, as shown in photos 2-7 and 2-8.

<2> Exterior Observations

Survey methods are measured drawings (figure 2-2, 2-3), Checklist, and photographs (photo 2-9 to 2-15).

Checklist 2-2

Exterior condition of the IOOF Hall in Garnett, Kansas

- * Size: The existing IOOF Hall is a rectangular three-story structure, approximately seventy-one feet in length and thirty-one feet in width.
- * Walls: The original red brick walls on the second and third floors are in good condition. On the first floor, however, the brick has been painted with light-green paint. Some of the paint has peeled off.
- * Windows: The window openings on all three floors are a simple rectangular shape of slightly different proportions from one to another. When referring to the old photographs on page 16 and page 17, it is found that the original windows on the first floor at the south facade has been altered to a single large opening. Such alteration has impaired the original intended style. The wood window frames are mostly in good condition, but the paint needs to be cleaned and re-painted. There is also glass broken on these window on which either plastic films or wood panels have been applied to patch up.

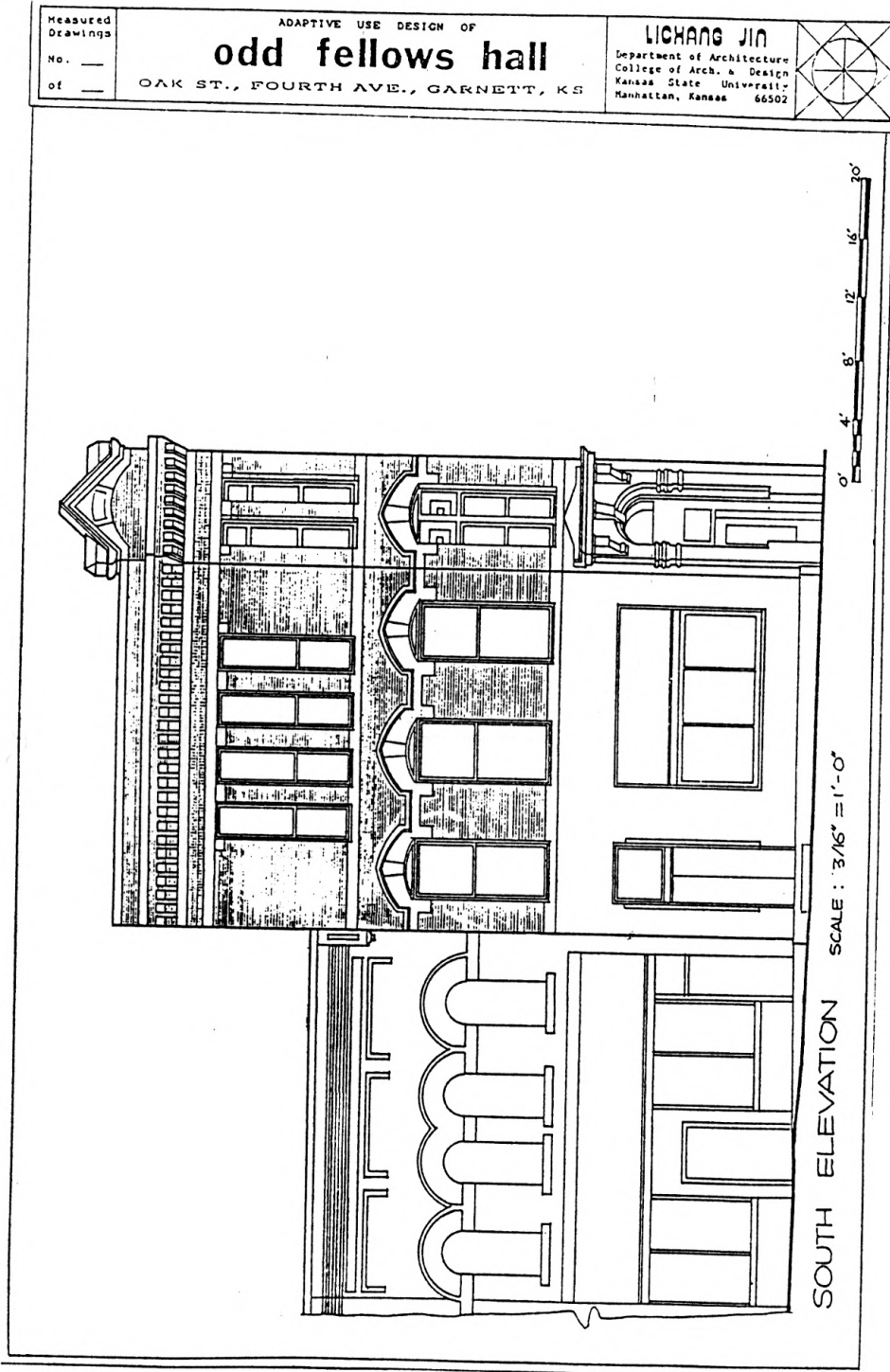

Figure 2-2 Measured Existing South Elevation
 (by Lichang Jin in May 1991)

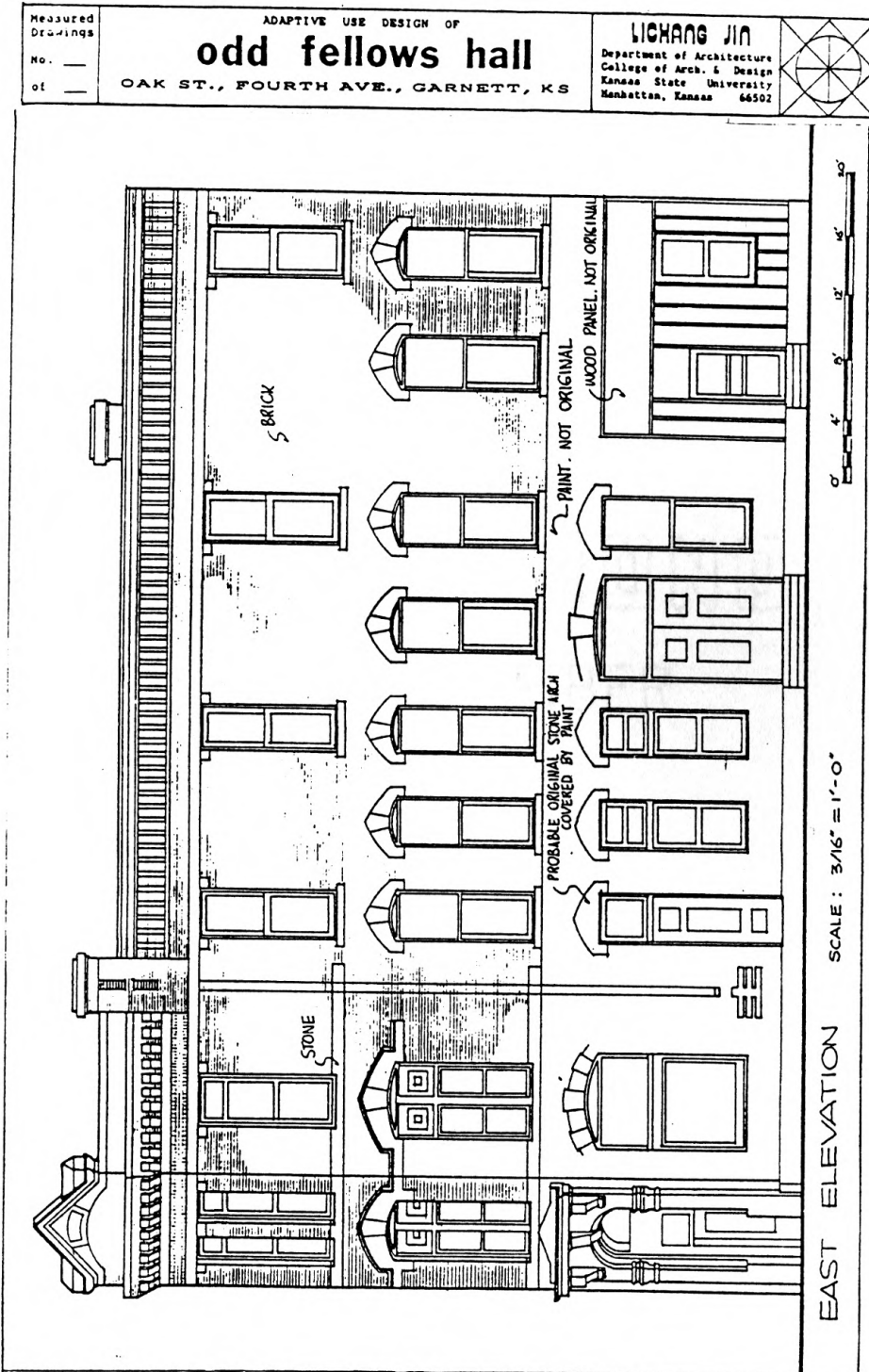

Figure 2-3 Measured Existing East Elevation
 (by Lichang Jin in May 1991)

photo
2-17

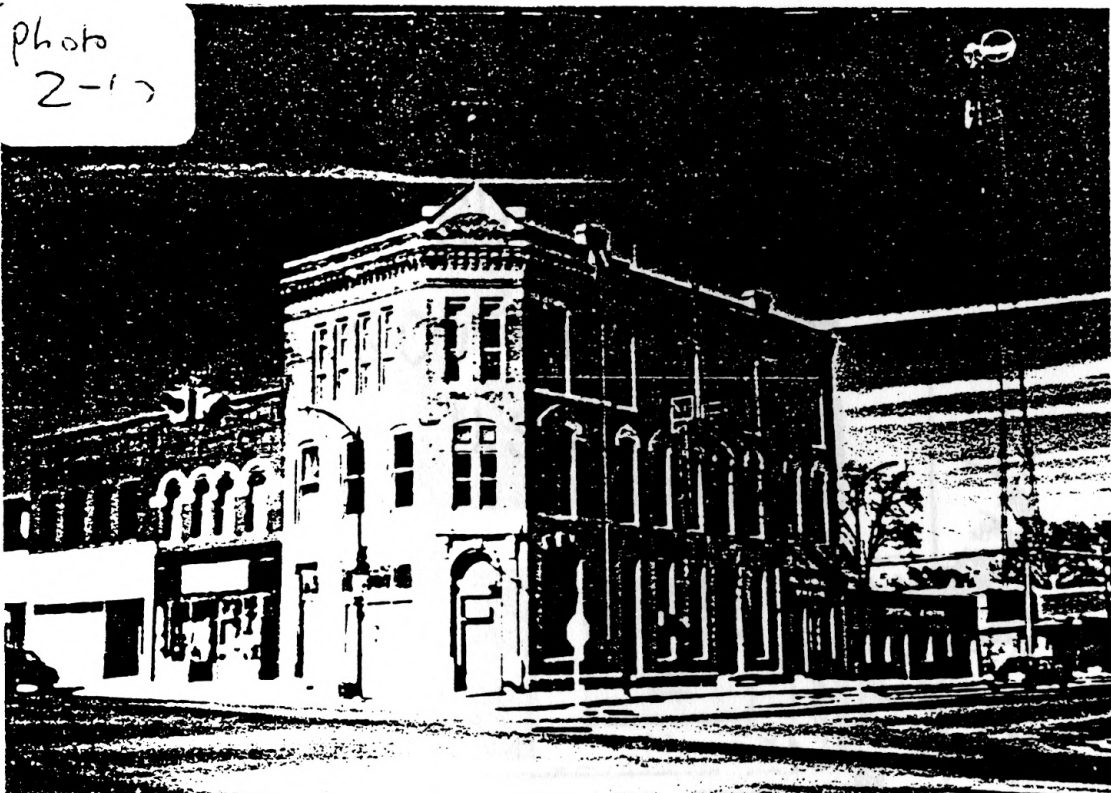

Photo 2-9 Existing Exterior Condition (A Panoramic View)
(Photo taken by Lichang Jin in January 1991)



Photo 2-10 Existing Exterior Condition (South Facade)
(Photo taken by Lichang Jin in January 1991)

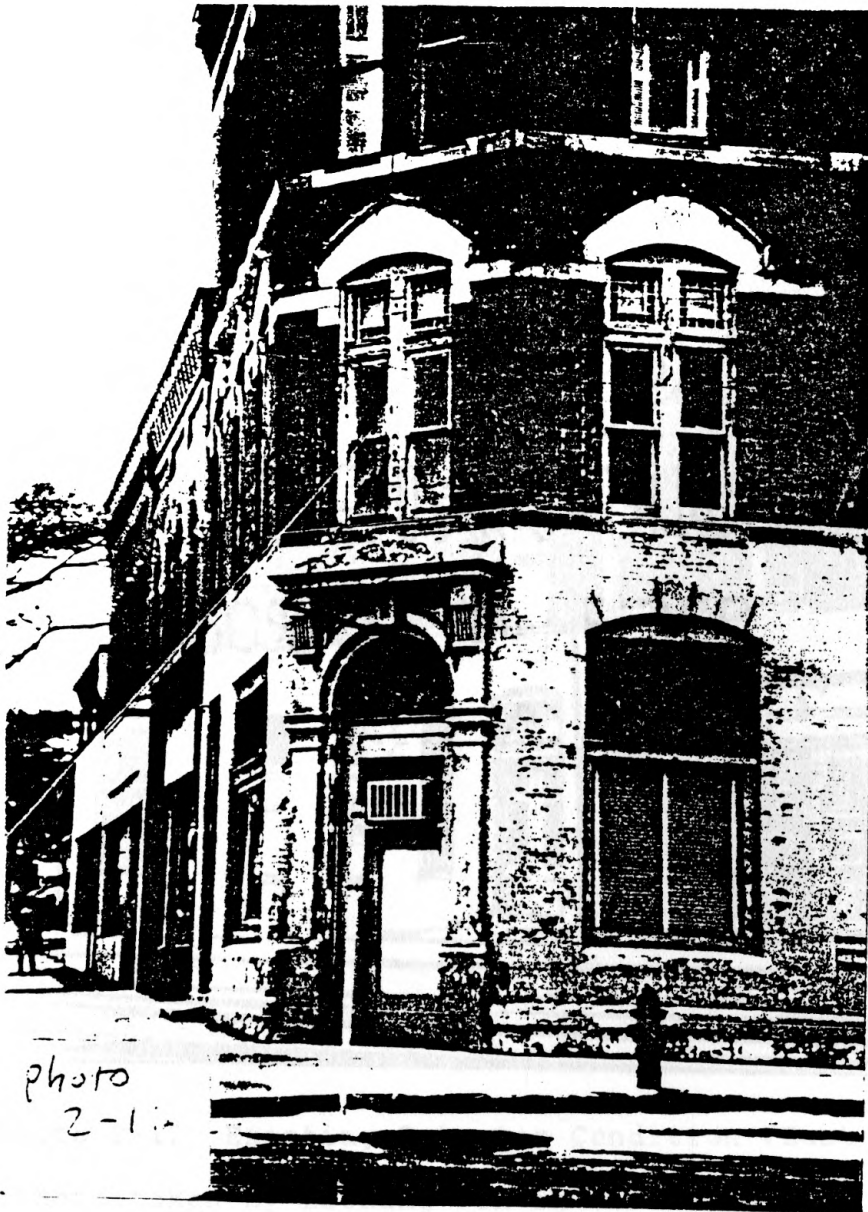

Photo 2-11 Existing Exterior Condition (Front Entrance)
(Photo taken by Lichang Jin in January 1991)



Photo 2-12 Existing Exterior Condition (East Facade)

(Photo taken by Lichang Jin in January 1991)

Existing Exterior Condition
East Facade, 1st & 2nd Floor, North portion. Photo taken in
January 1991 by Lichang Jin

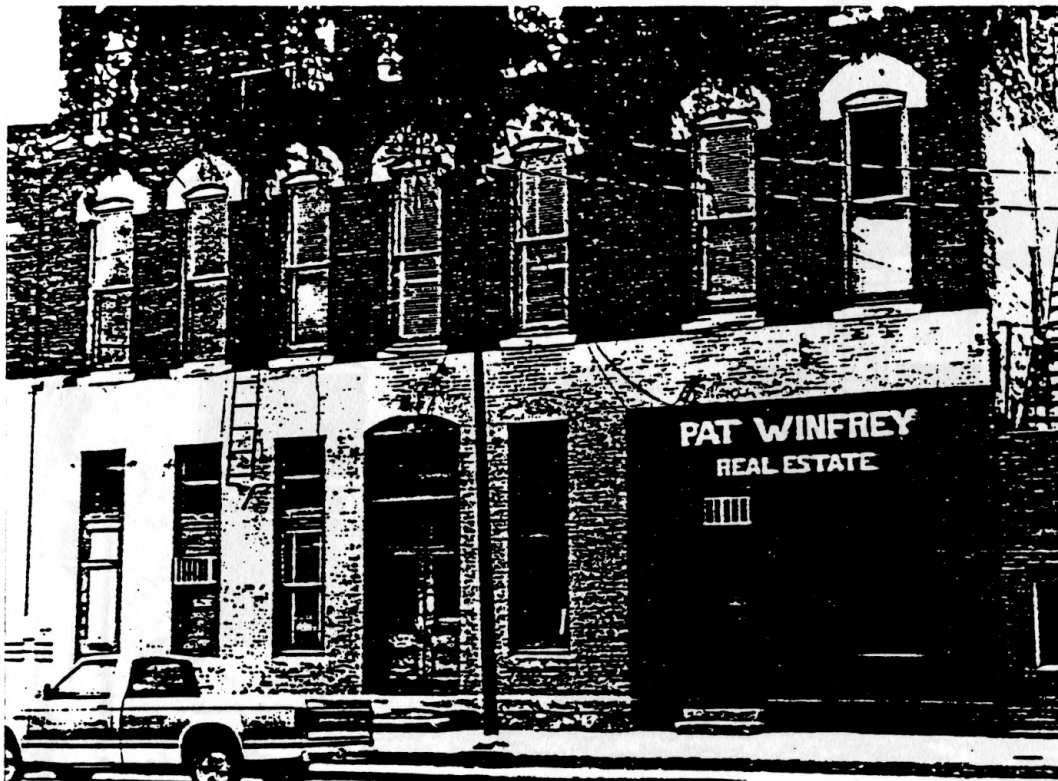

Photo 2-13

Existing Exterior Condition

(East Facade, 1st & 2nd floor, north portion, photo taken in
January 1991 by Lichang Jin)



Photo 2-14

Existing Exterior Condition

(East Facade, 1st & 2nd floor, south porttion; photo taken by Lichang Jin in January 1991)

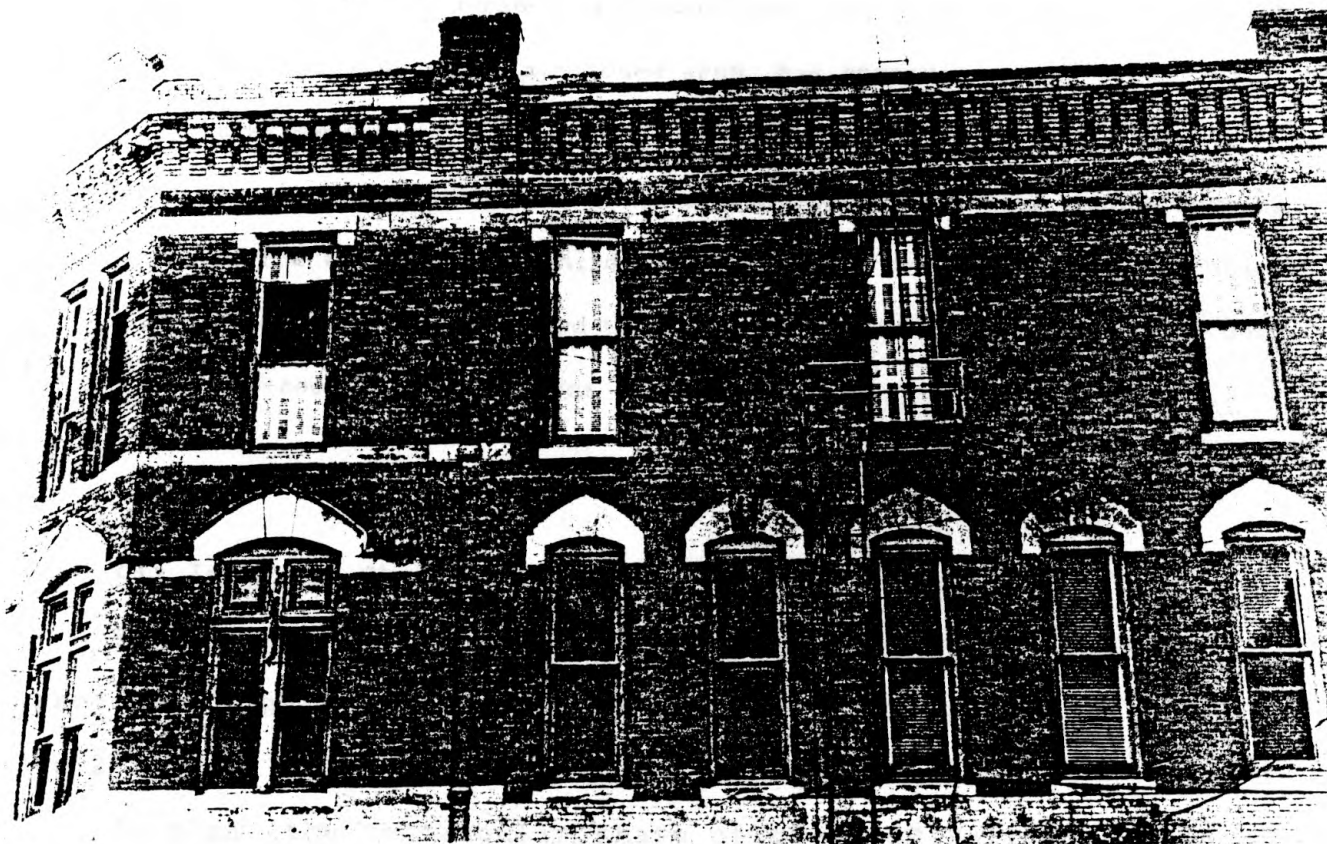

Photo 2-15

Existing Exterior Condition

(East Facade, 2nd & 3rd floor, south portion; photo taken by
Lichang Jin in January 1991)

- * Lintels: The arch-shape stone lintels over the first and second floor windows at the south and east facade appear to be impressive. The lintels at the second floor at the south facade are linked horizontally by a stone belt and carved in a similar fashion with the lintels.
- * Entries: There are currently five entries into the building. One at the south facade leads up to the second floor. One at the east facade to the north end leads into Pat Winfrey's Real Estate Office. The other three lead only onto the first floor. The corner entry at the front was the original main entrance to the building. Its stone frame, bordered with two columns and a key-stoned arch, has engravings with fine craftsmanship.
- * Others: At the east facade, there is a ladder used as a fire escape hanging on the wall from the third floor. There is another fire escape which is a stair-case attached to the north-side wall, which goes down onto the roof of the Cleaners building.

<3> Interior Observations

Survey methods are measured drawings (figure 2-4, 2-5, 2-7), sketches (figure 2-6, 2-8), checklist, and photographs (photo 2-16 to 2-38).

In plan, the rectangular shape of the IOOF Hall is broken at the south-east corner which is cut off to provide a main entrance to the first floor. The total gross floor area is 6,580 square feet, with each floor being 2,193 square feet.

Checklist 2-3

Interior condition of the IOOF Hall in Garnett, Kansas

First Floor (refer to figure 2-4 for the space numbering):

- * Space #1 - former fitness room; net floor area: 1,050 sq ft; floor to ceiling height: 14'-55"; proportion: 38'-4" by 28'-4";
- * Space #2 - former office room; net floor area 152 sq ft; floor to ceiling height: 14'-8"; proportion: 9'-6" by 16'-1"; west side wall is wooden partition (not original);
- * Space #3 - former office room; net floor area: 217 sq ft; floor to ceiling height: 14'-8"; proportion: 18'-2" by 16'-1"; only its north side wall is original, all others were built later;
- * Space #4 - former restroom; net floor area: 42 sq ft; floor to ceiling height: 14'-8"; proportion: 6'-10" by 6'-2"; created later;
- * Space #5 - present Pat Winfrey Real Estate Office; net floor area: 316 sq ft; floor to ceiling height: 14'-8"; proportion: 14'-4" by 22'-4"; has access to staircase;

Second Floor (refer to figure 2-5 for the space numbering):

- * Space #7 - lobby and stairwell; net floor area: 387 sq ft; floor to ceiling: 12'-2"; stair width: 4'-2" (average); stair tread: 0'-12", rise: 0'-6" (average);
- * Space #8 - former office room; net floor area: 647 sq ft; floor to ceiling height: 12'-2"; proportion: 36'-10" by 18'-5"; exposed wooden beam; ceiling needs repair;
- * Space #9 - former office room; net floor area: 249 sq ft; floor to ceiling height: 12'-2"; proportion: 13'-7" by 18'-5"; has sink outlet;

- * Space #10 - former office room; net floor area: 398 sq ft; floor to ceiling height: 12'-2"; proportion: 23'-0" by 18'-2" (irregular); has good view of the Square; remains in good condition;
- * Space #11 - former closet room; net floor area: 49 sq ft; floor to ceiling height: 12'-2"; proportion: 4'-5" by 10'-9"; original;
- * Space #12 - former closet room; net floor area: 41 sq ft; floor to ceiling height: 12'-2"; proportion: 5'-9" by 7'-3"; original; has a south window;

Third Floor (refer to figure 2-7 for the space numbering):

- * Space #13 - former IOOF meeting hall; net floor area: 1,550 sq ft; floor to ceiling height: 14'-0"; proportion: 55'-4" by 28'-4" (irregular); largest space of the building; nice view of Square; good ceiling; original carpet but needs cleaning; mural painting partly peeled off; four wooden platforms rise up 0'-6" against each wall; original chairs;
- * Space #14 - former IOOF kitchen; net floor area: 197 sq ft; floor to ceiling height: 14'-0"; proportion: 13'-10" by 14'-4"; has sink outlet; original;
- * Space #15 - former IOOF waiting room; net floor area: 123 sq ft; floor to ceiling height: 14'-0"; proportion: 8'-6" by 14'-4"; ceiling needs repair; original;
- * Space #16 - stairwell; net floor area: 55 sq ft; floor to ceiling: 14'-0"; stair width: 2'-11"; stair tread: 0'-10", rise: 0'-7" (average); ceiling needs repair;

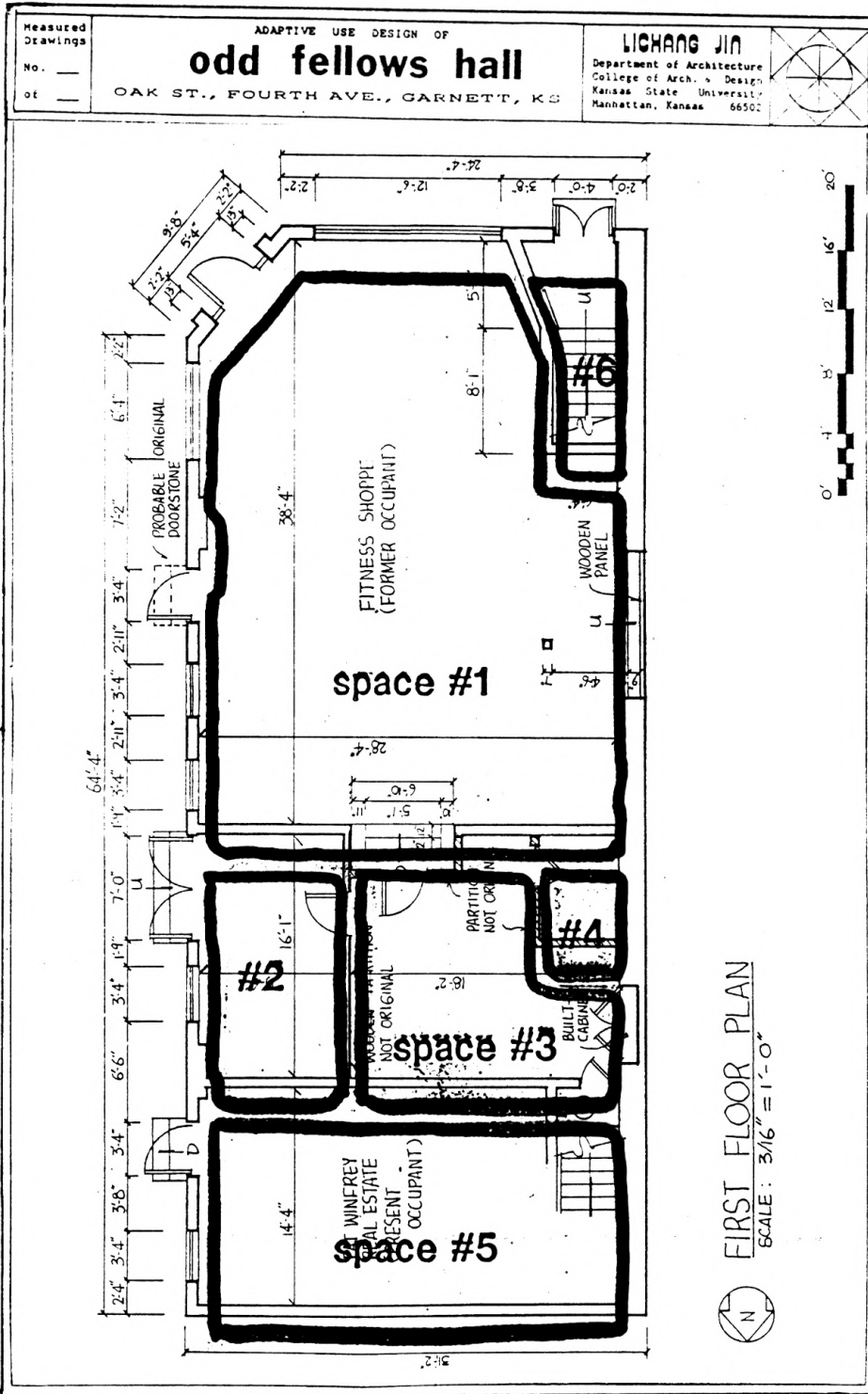

Figure 2-4 Measured Existing First Floor Plan
(By Lichang Jin in May 1991)

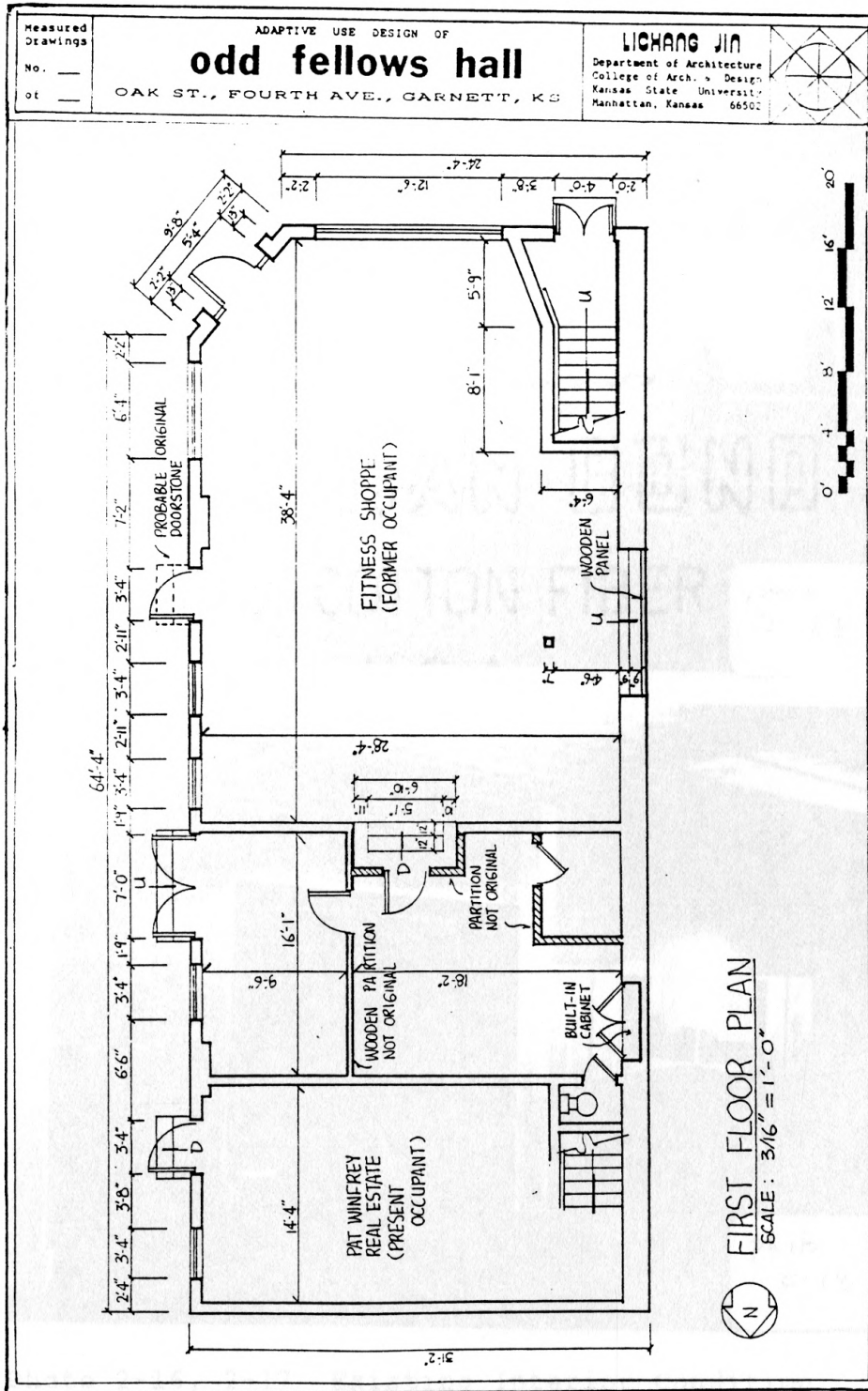

Figure 2-4 Measured Existing First Floor Plan
 (By Lichang Jin in May 1991)

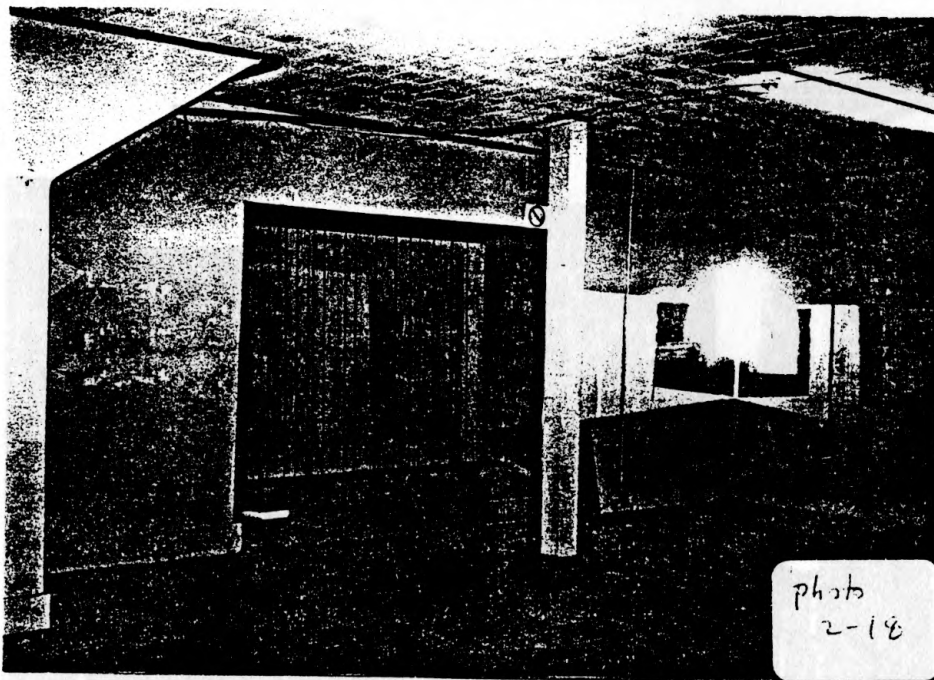
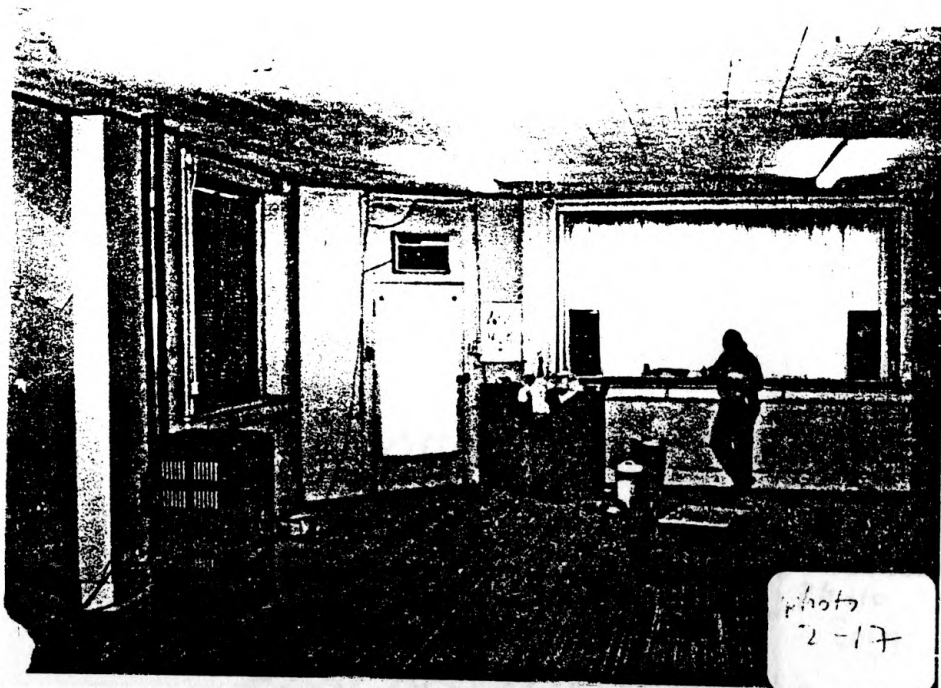

Photo 2-16, 2-17 Existing Interior Condition

- 1st Floor View, Space #1

(Photos taken in January 1991 by Lichang Jin)

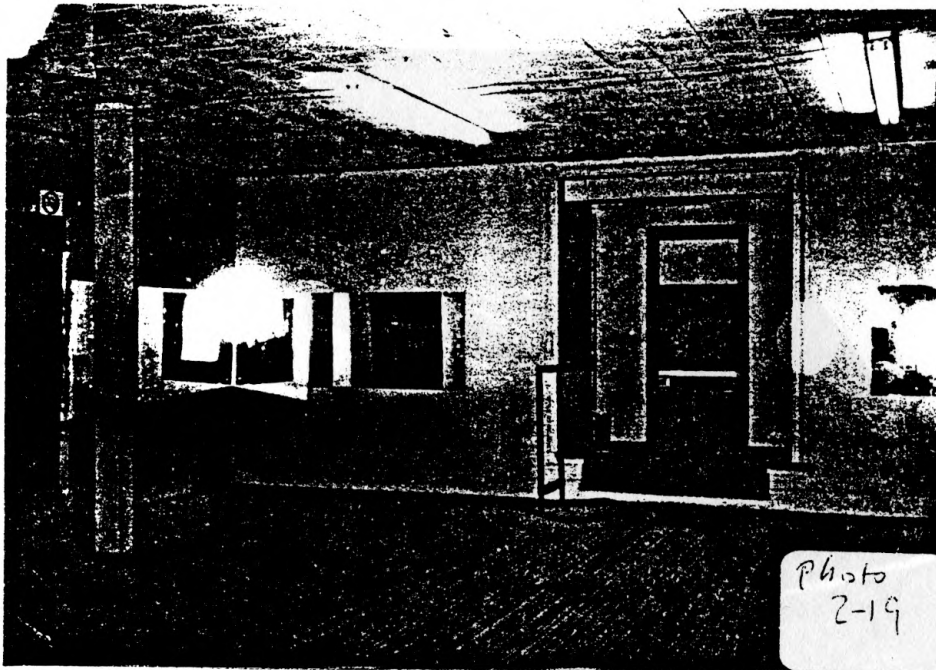

photo
2-20

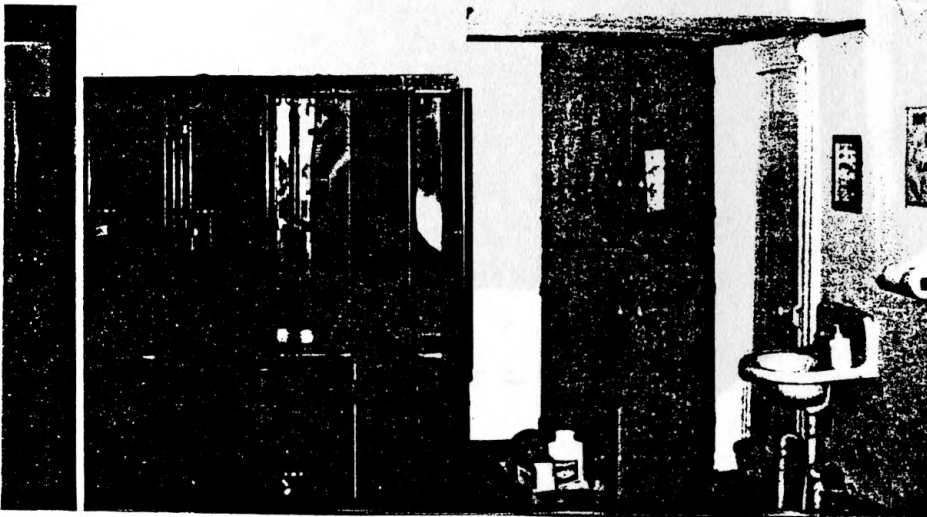
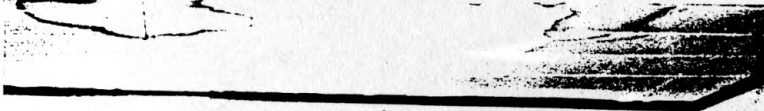

Photo 2-18 (above) Existing Interior Condition-1st Floor, Space #1
Photo 2-19 (below) Existing Interior Condition-1st Floor, Space #3
(Photos taken in January 1991 by Lichang Jin)

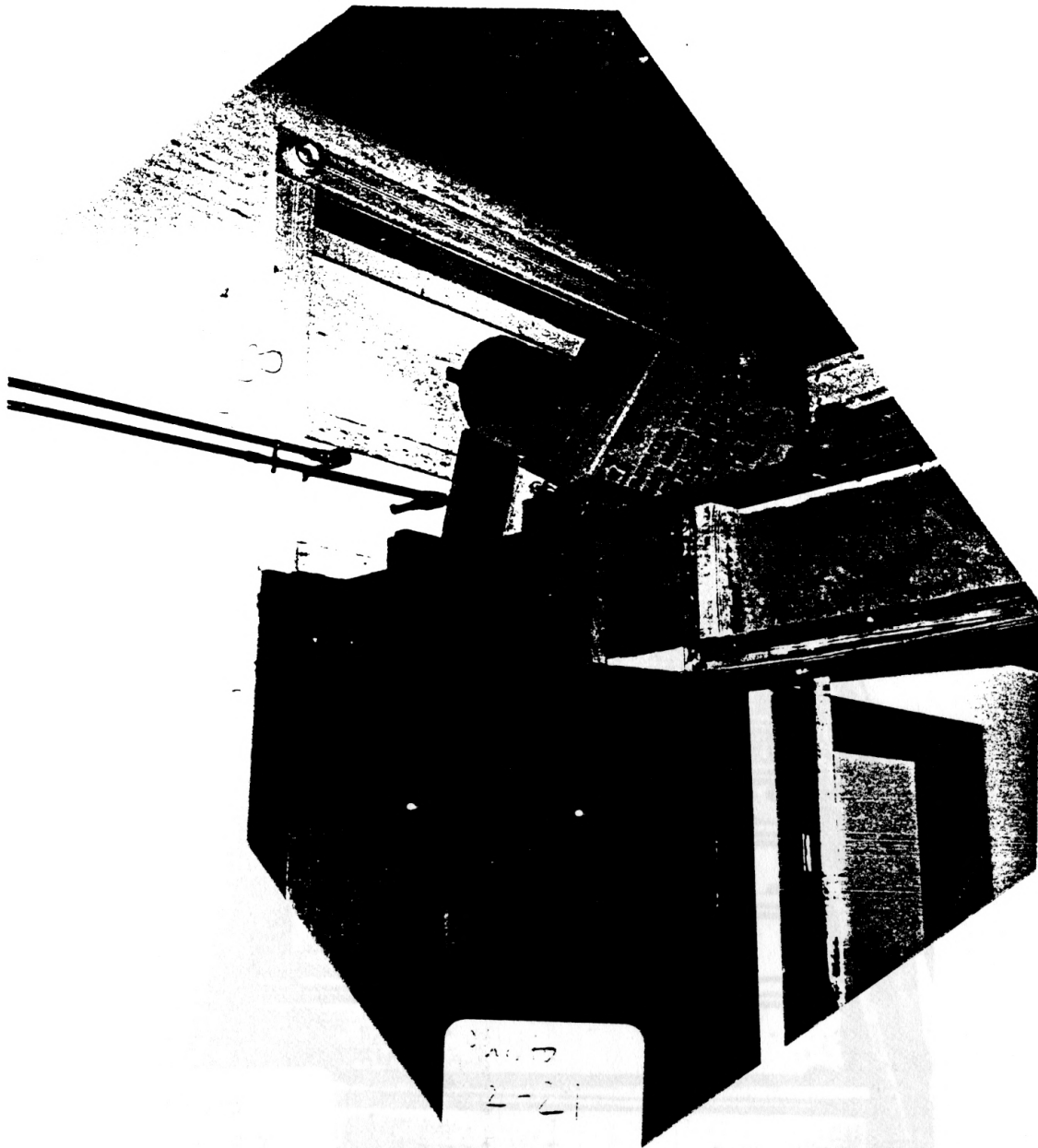

Photo 2-20 Existing Interior Condition - 1st Floor, Space #2
(Photo taken in January 1991 by Lichang Jin)



photo
2-22

Photo 2-21 Existing Interior Condition - 1st Floor, Space #6
(Photo taken in January 1991 by Lichang Jin)

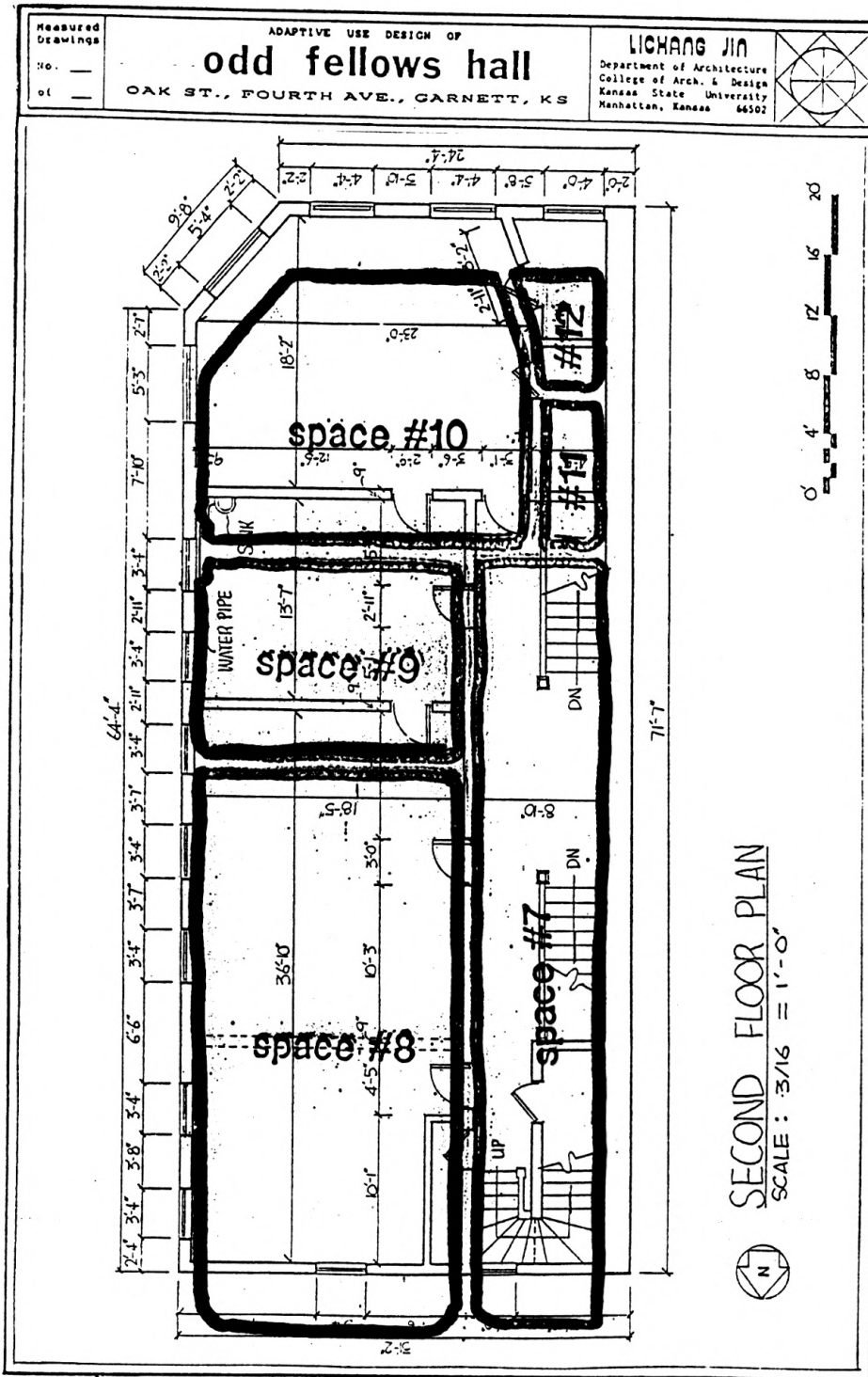

Figure 2-5 Measured Existing Second Floor Plan
(By Lichang Jin in May 1991)

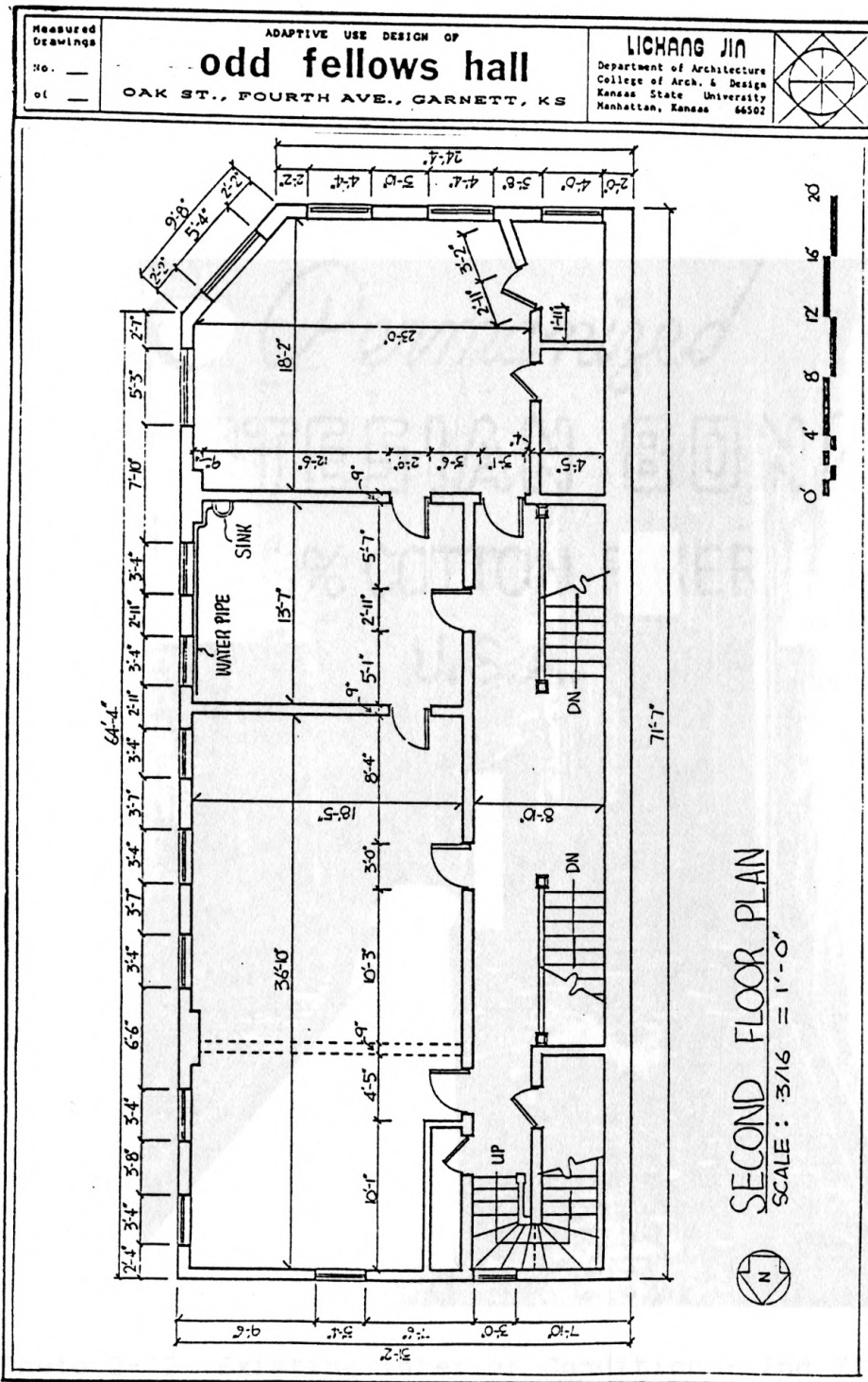

Figure 2-5 Measured Existing Second Floor Plan
 (By Lichang Jin in May 1991)



Photo 2-22 Existing Interior Condition - 2nd Floor, Space #7
(Photo taken in January 1991 by Lichang Jin)

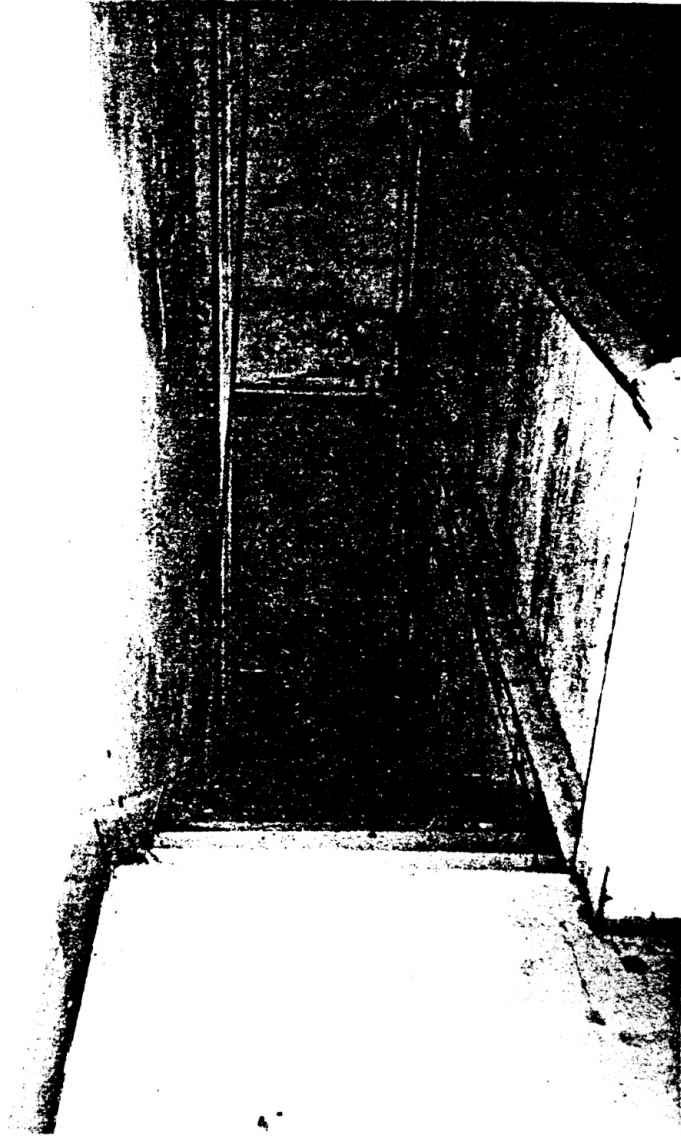

Photo 2-23 Existing Interior Condition - 2nd Floor, Space #7
(Photo taken in January 1991 by Lichang Jin)



Photo 2-24 Existing Interior Condition - 2nd Floor, Space #7

(Photo taken in January 1991 by Lichang Jin)

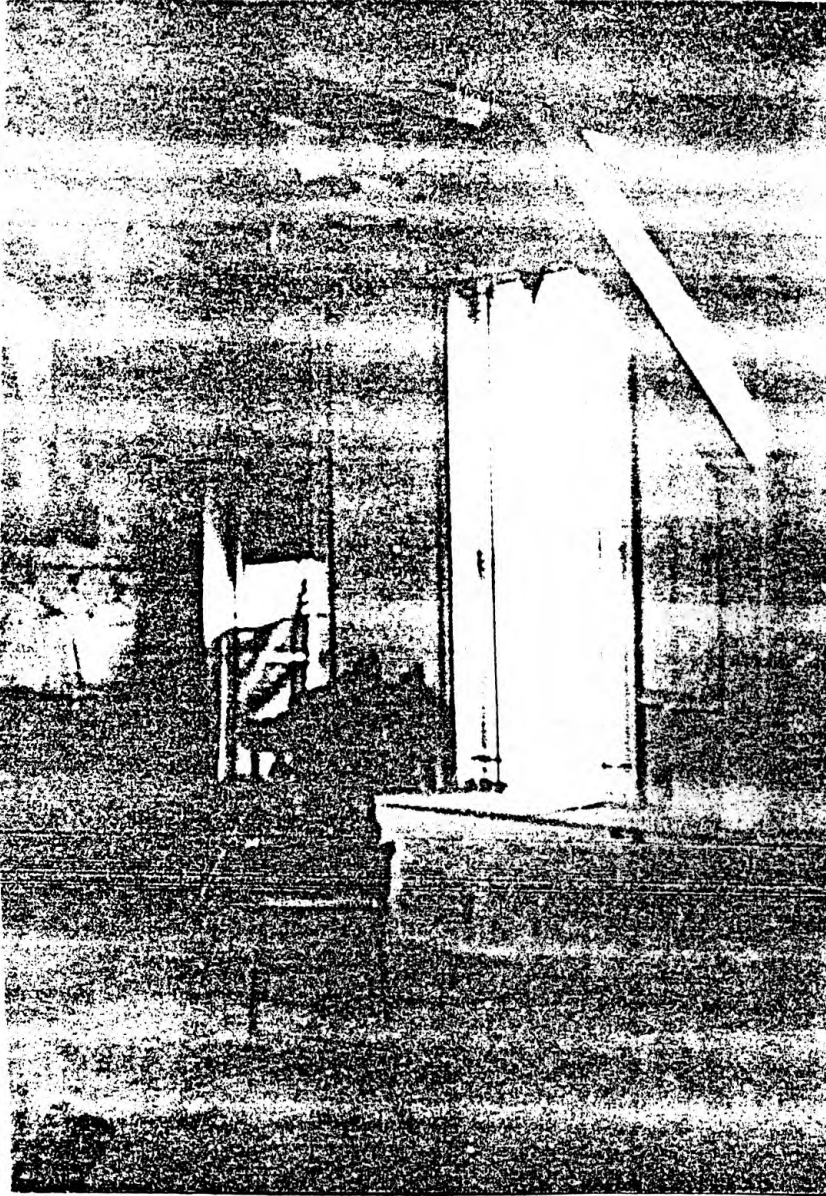

Photo 2-25 Existing Interior Condition - 2nd Floor, Space #8
(Photo taken in January 1991 by Lichang Jin)

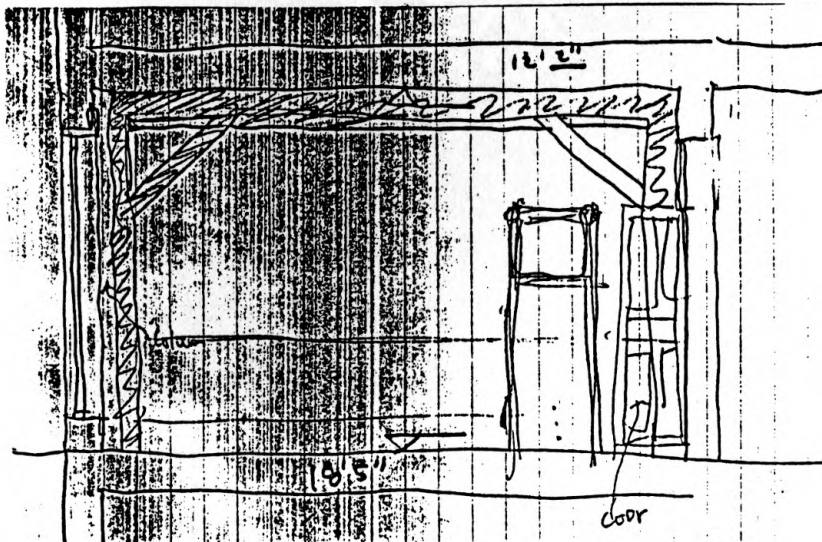
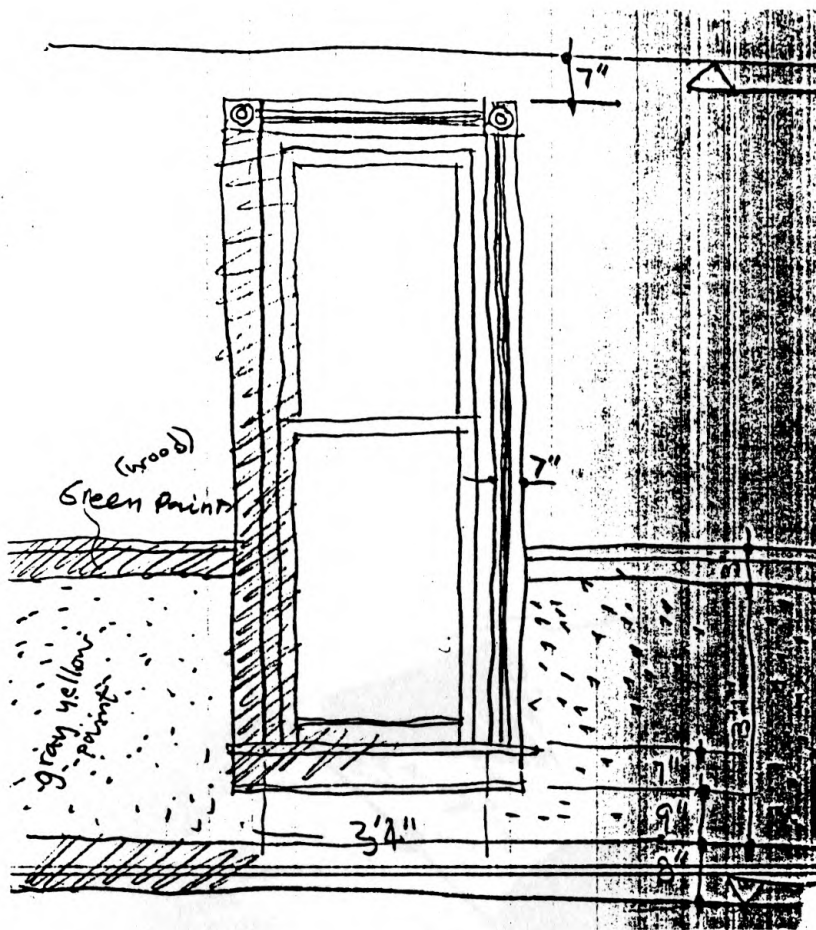

Figure 2-6

Survey Sketches of Existing 2nd Floor - Space #8 & Details

(By Lichang Jin in January 1991)

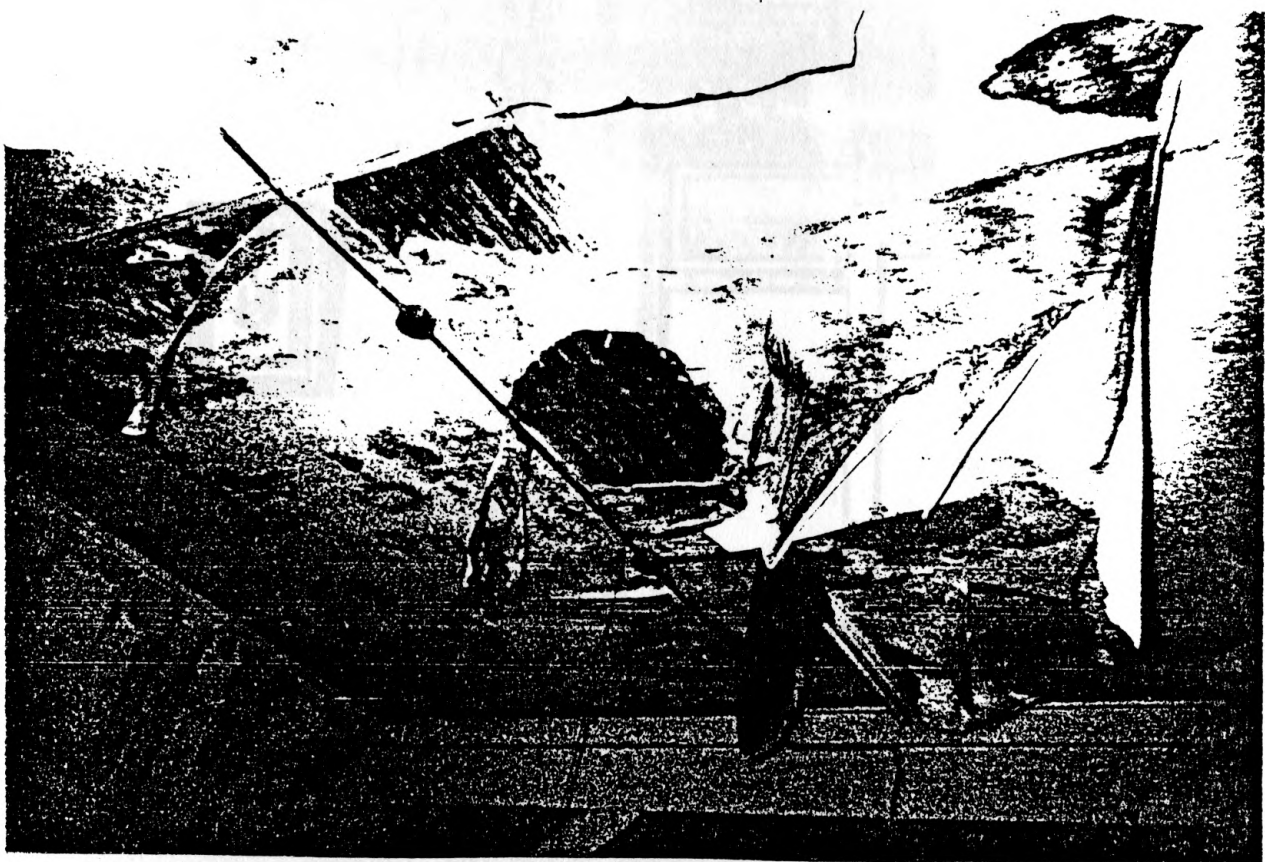

Photo 2-26 Existing Interior Condition - 2nd Floor, Space #8
(Photo taken in January 1991 by Lichang Jin)



Photo 2-27 Existing Interior Condition - 2nd Floor, Space #9
(Photo taken in January 1991 by Lichang Jin)

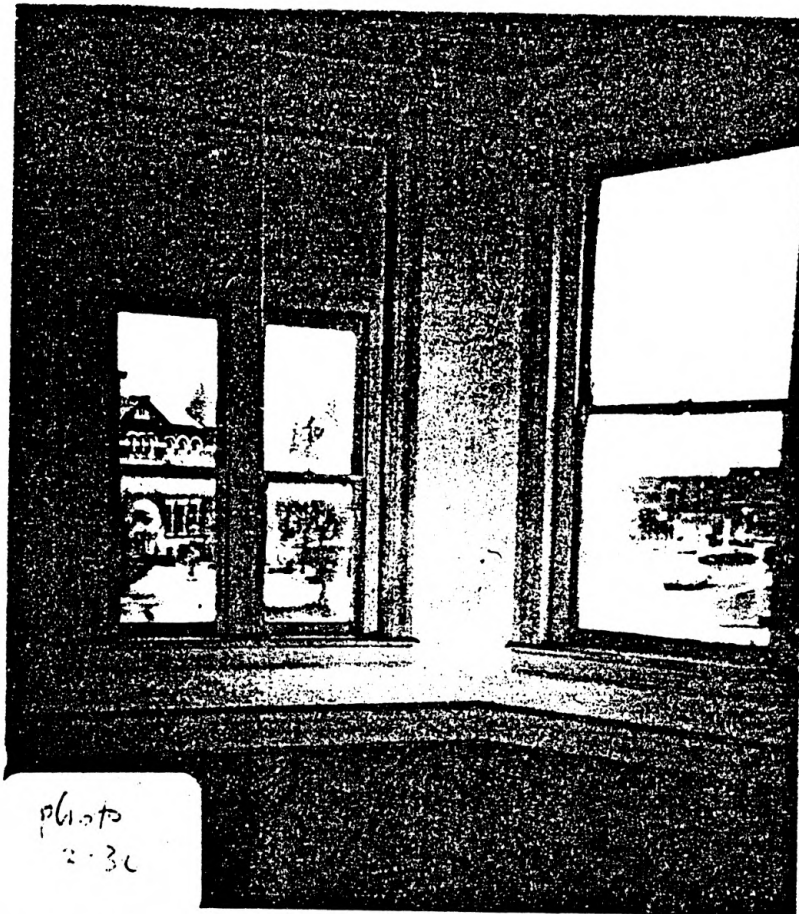

Photo 2-28 Existing Interior Condition - 2nd Floor, Space #10
(Photo taken in January 1991 by Lichang Jin)

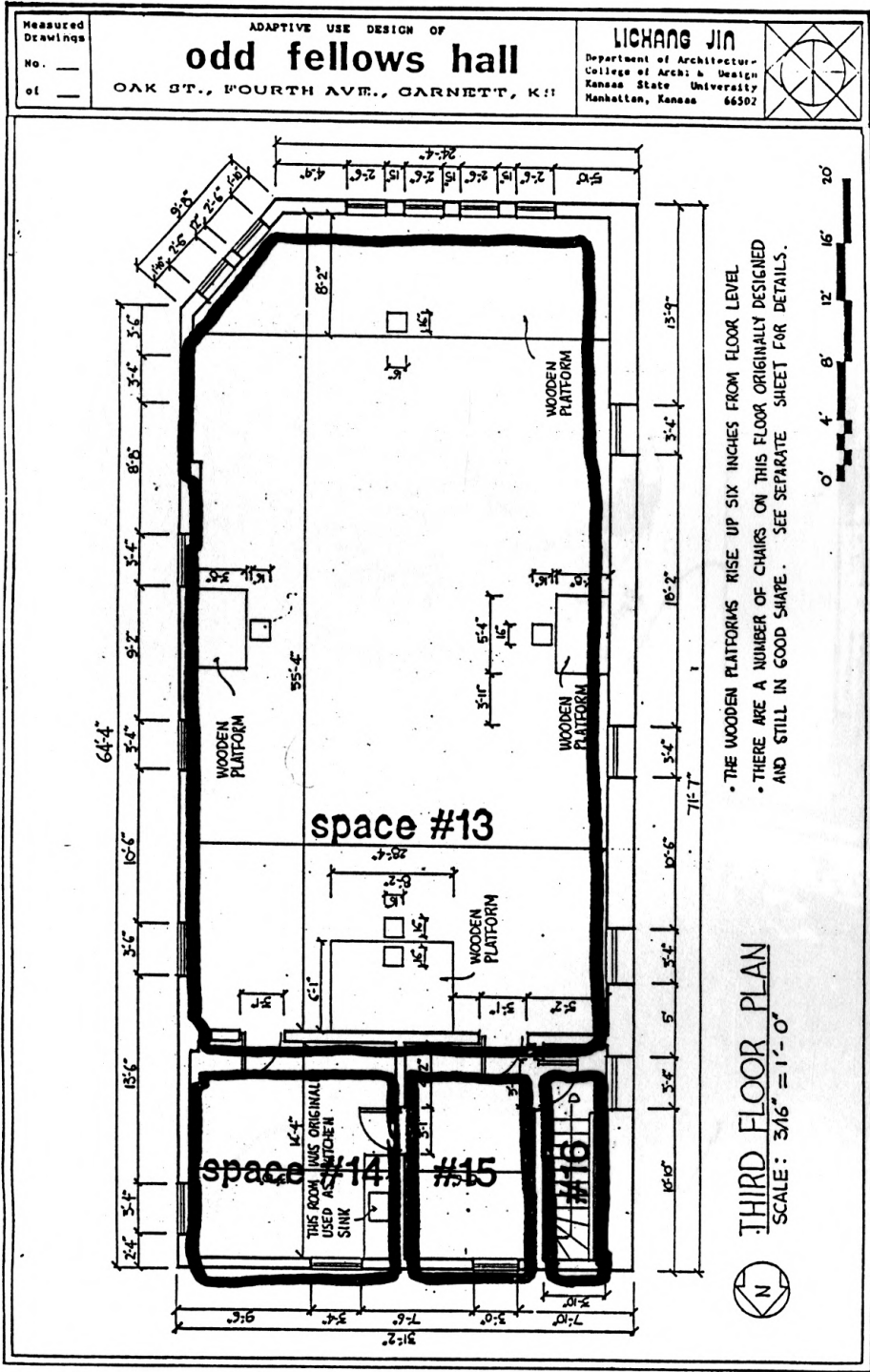

Figure 2-7 Measured Existing Third Floor Plan
 (By Lichang Jin in May 1991)

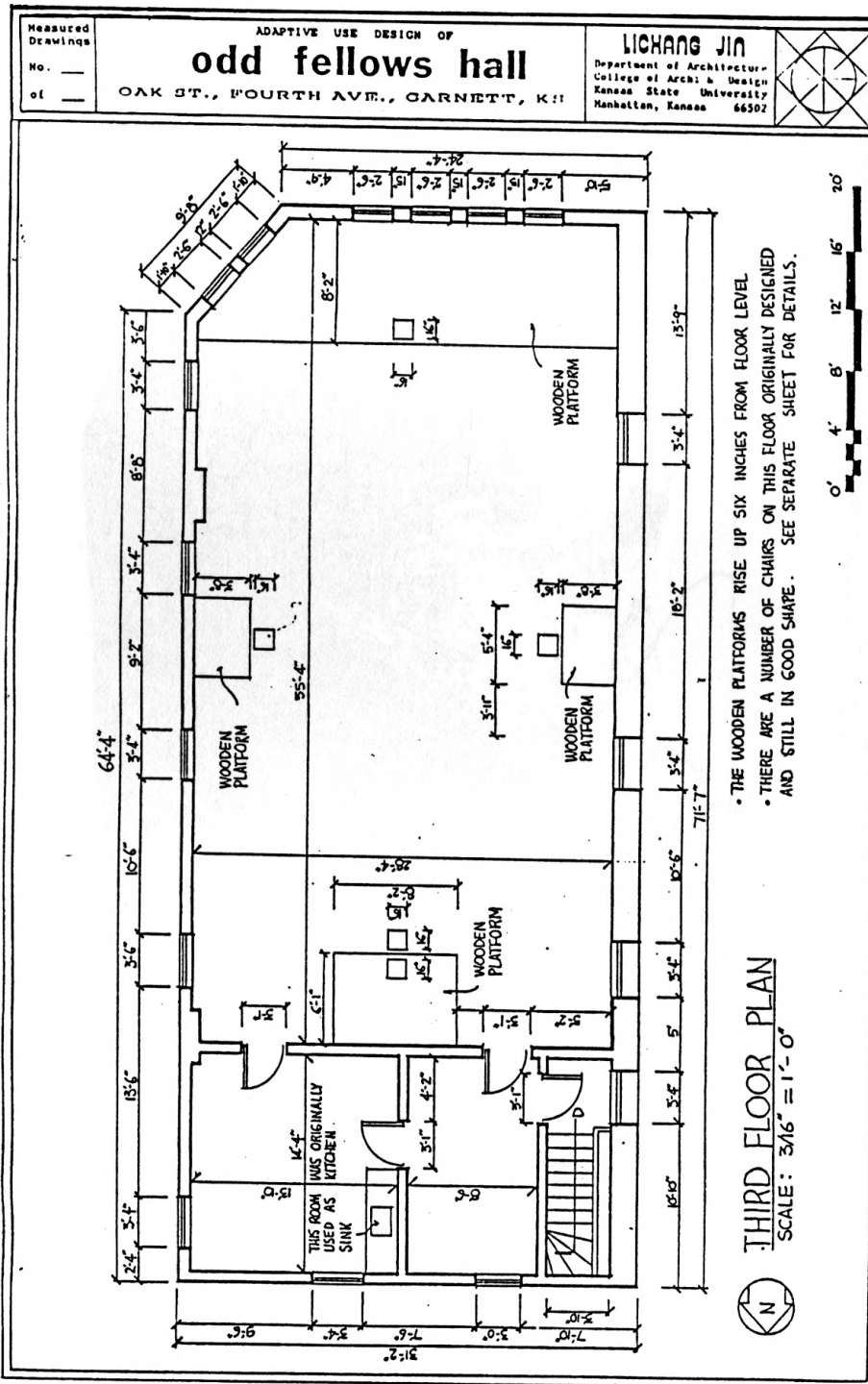

Figure 2-7 Measured Existing Third Floor Plan
(By Lichang Jin in May 1991)



Photo 2-29 Existing Interior Condition - 3rd Floor, Space #16
- Detail of Stairs
(Photo taken in January by Lichang Jin)



Photo 2-30 Existing Interior Condition - 3rd Floor, Space #16
- Upper Stairwell

(Photo taken in January 1991 by Lichang Jin)

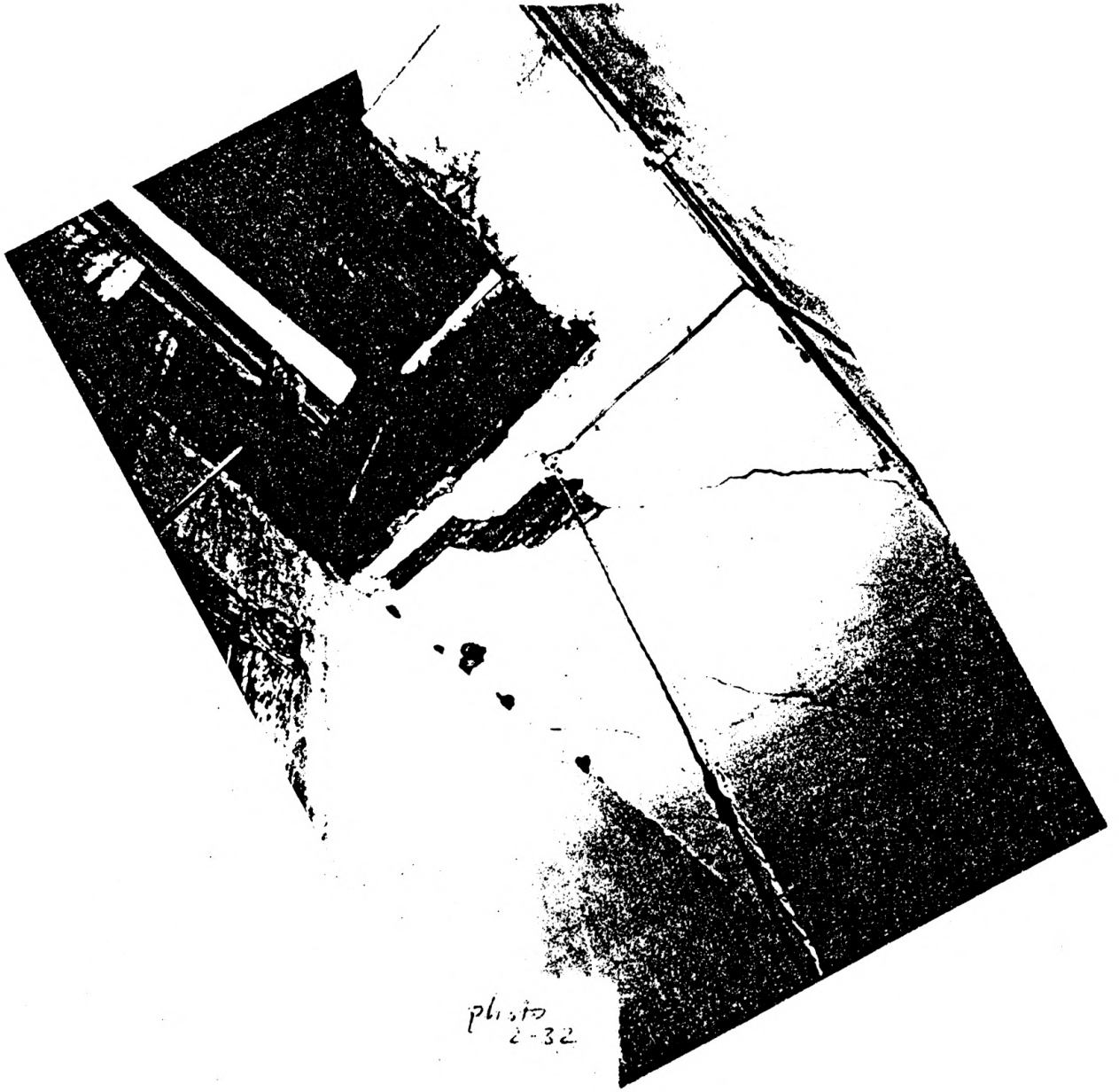

Photo 2-31 Existing Interior Condition - 3rd Floor, Space #16
- Ceiling of Stair Well

(Photo taken in January 1991 by Lichang Jin)

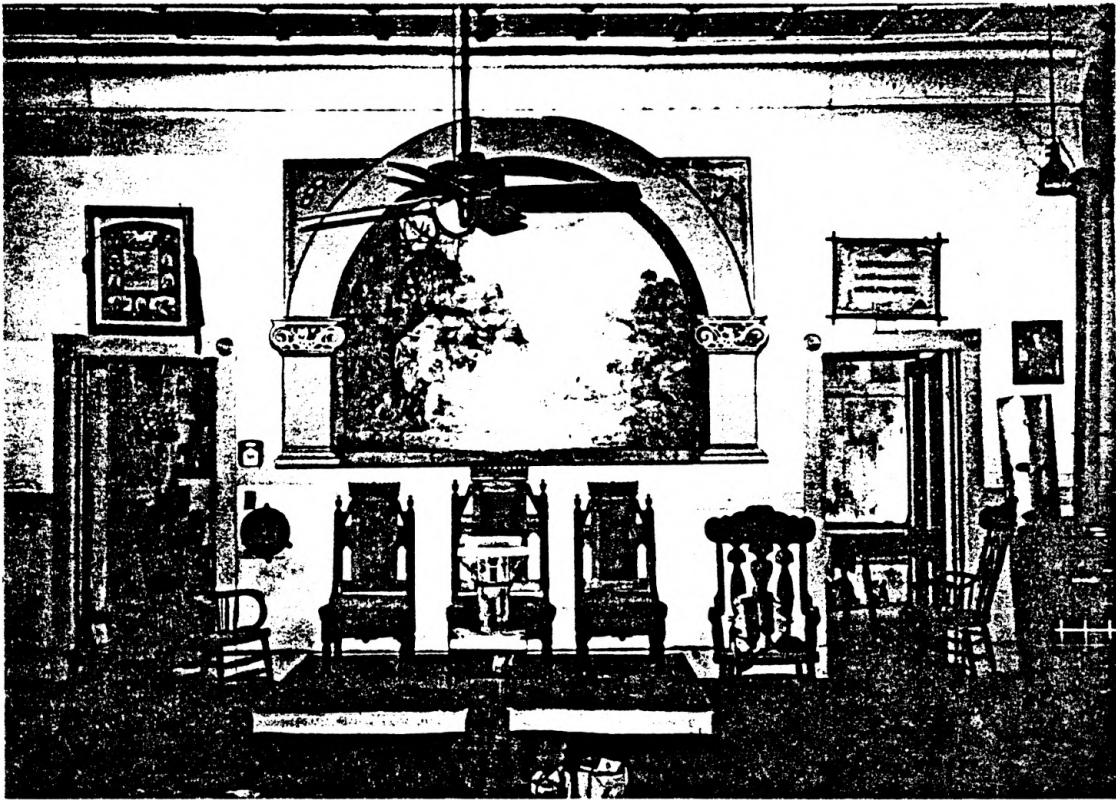

Photo 2-32 Existing Interior Condition - 3rd Floor, Space #13
- North End

(Photo taken in January 1991 by Lichang Jin)

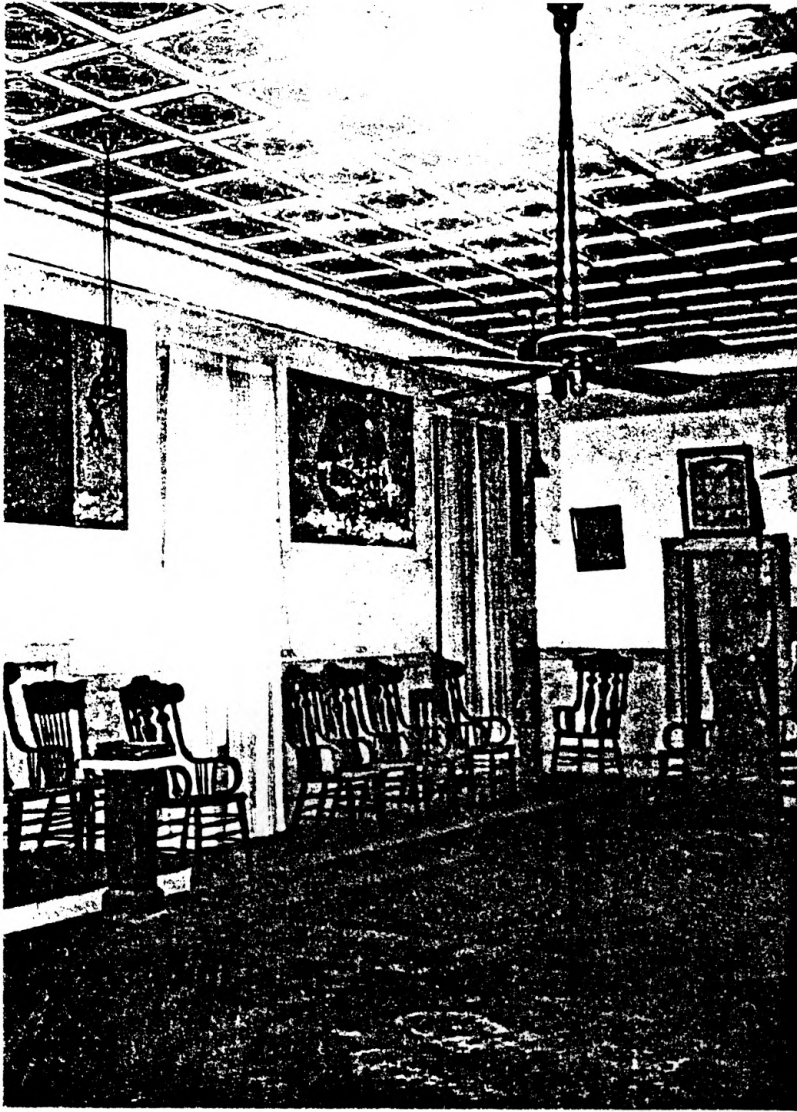

Photo 2-33 Existing Interior Condition - 3rd Floor, Space #13

- West Wall

(Photo taken in January 1991 by Lichang Jin)



Photo 2-34 Existing Interior Condition - 3rd Floor, Space #13
- Wooden Platform to East Wall and Chairs
(Photo taken in January 1991 by Lichang Jin)

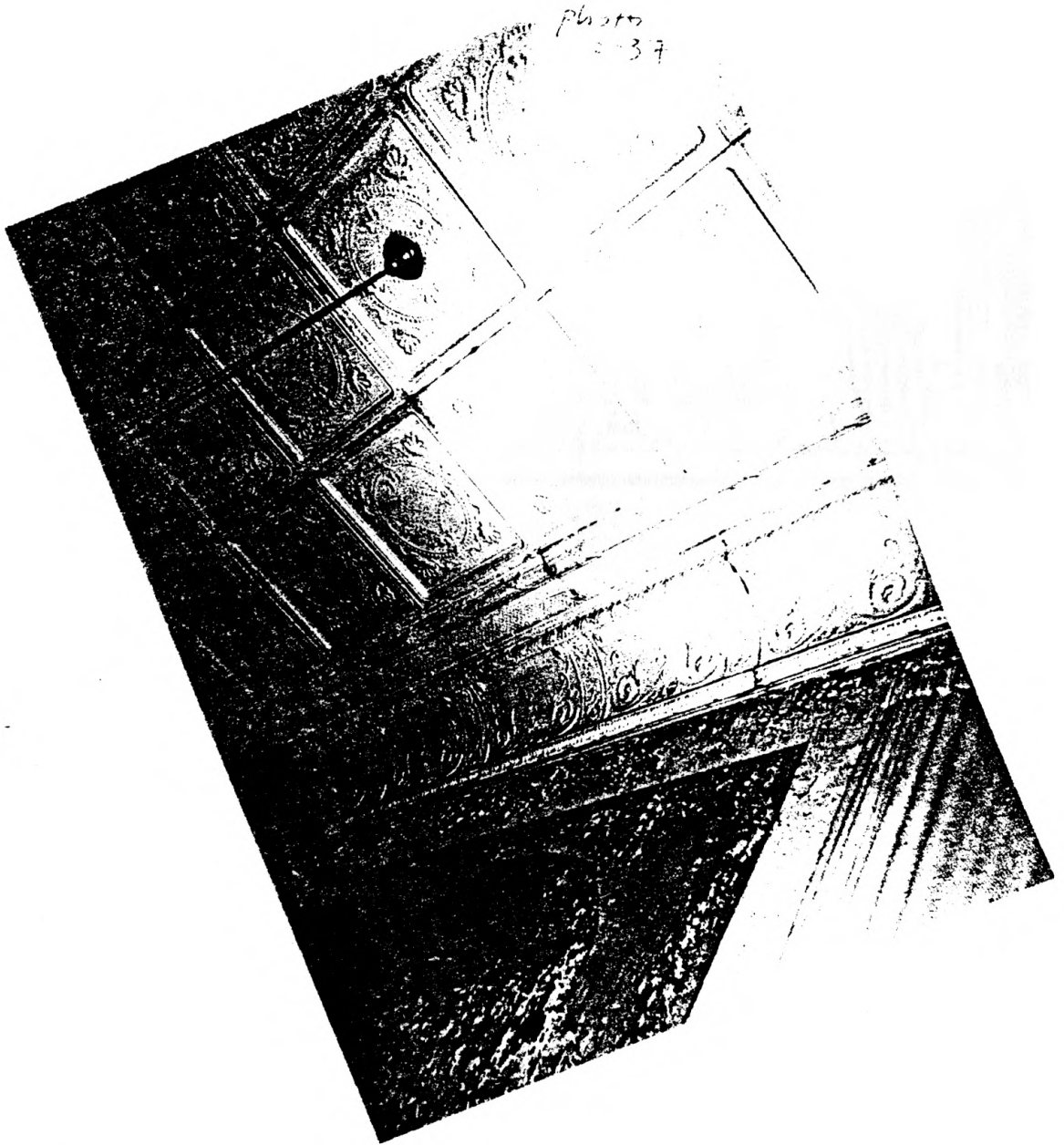

Photo 2-35 Existing Interior Condition - 3rd Floor, Space #13
- Plaster Ceiling

(Photo taken in January 1991 by Lichang Jin)

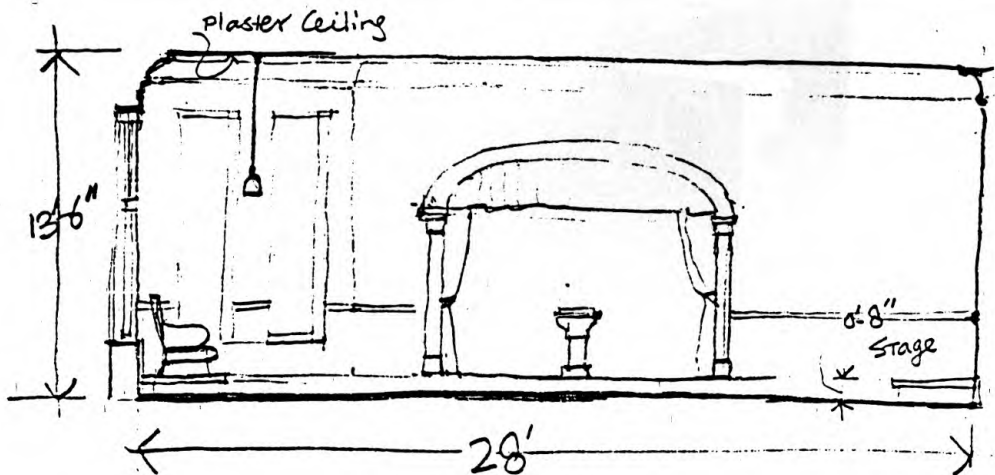
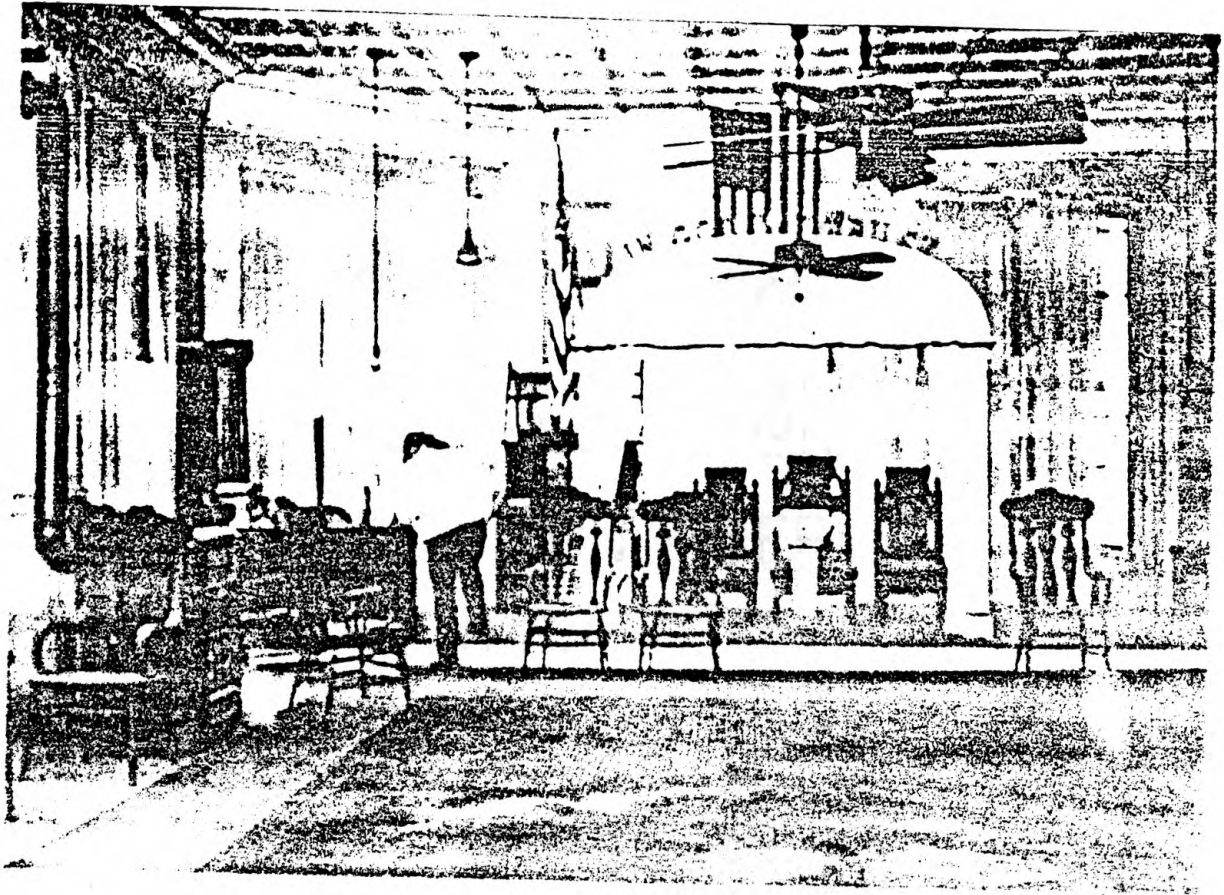

Photo 2-36 Existing Interior Condition - 3rd Floor, Space #13
 - South End (Photo taken in January 1991 by Lichang Jin)

Figure 2-8 Survey Sketch of 3rd Floor Meeting Hall - South End
 (By Lichang Jin in January 1991)

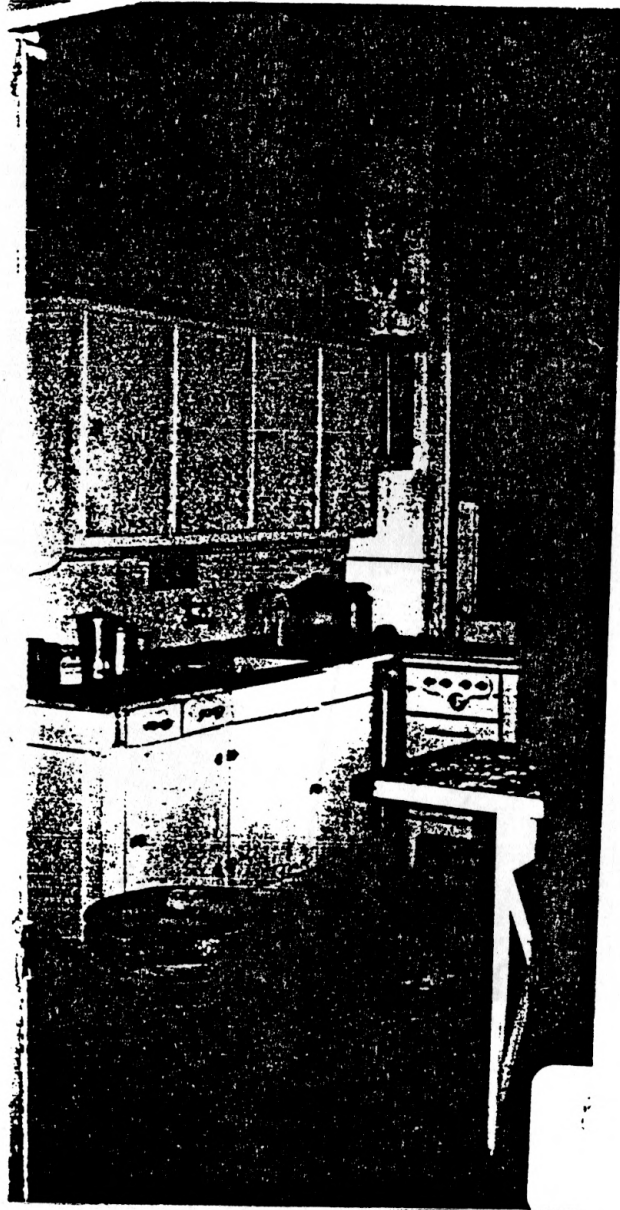

Photo 2-37 Existing Interior Condition - 3rd Floor, Space #14
- Former Kitchen

(Photo taken in January 1991 by Lichang Jin)

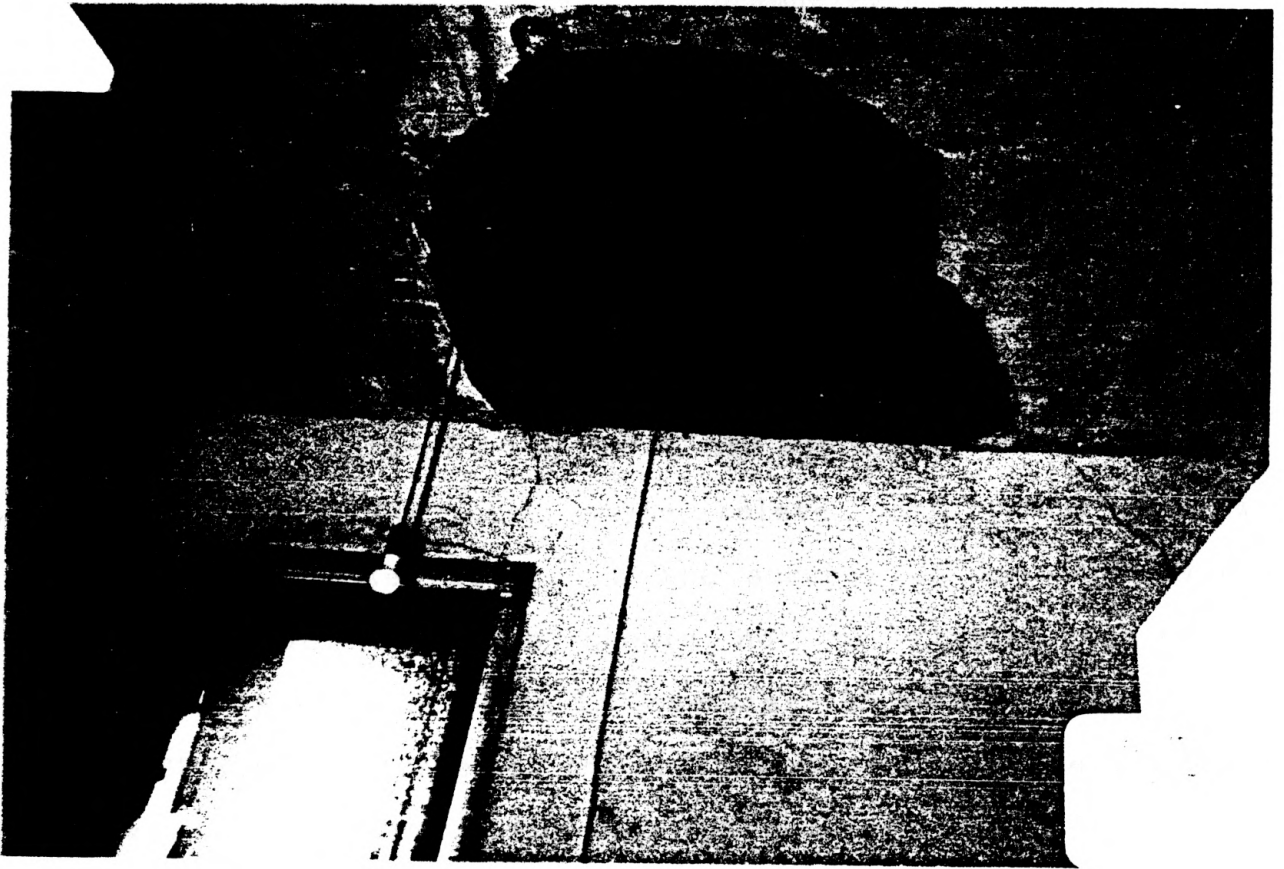

Photo 2-38 Existing Interior Condition - 3rd Floor, Space #15

- Ceiling of the Former Waiting Room

(Photo taken in January 1991 by Lichang Jin)

Chapter 3

AN ADAPTIVE-USE PROPOSAL

This chapter examines two issues that prevail in this adaptive-use project: <1> why the building should be saved; <2> how to use it as a device to serve the community.

<1> Three Reasons Make It Worth Saving

First, it must be remembered that the vast majority of buildings in American cities will not, when individually considered, have any great historic or artistic significance¹⁸. Most older buildings do not exist in isolation from other structures. The extent to which an old building's size, materials, color, and architectural style relate comfortably with its neighbors is a key factor in the success of any preservation effort¹⁹. Old buildings should not be treated as movable artifacts. A sense of place is essential. As noted in Chapter One, the IOOF Hall is located at the north-west corner of the Courthouse Square. Contextually, it has been the most imposing building in the downtown area except the Courthouse, and has an urbanistic role in the streetscape in its size, material, color, and style.

Secondly, this building is the oldest structure remaining in downtown Garnett. It is architecturally distinct, a fine example of

¹⁸. Fitch, James, M., HISTORIC PRESERVATION: Curatorial Management of the Built World, pp. 169.

¹⁹. Shopsin, William C., RESTORING OLD BUILDINGS FOR CONTEMPORARY USES, 1982, pp. 25.

a late nineteenth century stone and brick structure building.

The third reason is the fact that it remains in good shape structurally and artistically.

<2> Preservation Alternatives

As mentioned earlier, there have been voices over the past years from inside the community calling for painting-up this building in order to beautify downtown. Recently, the author was informed that this appeal will soon be carried out. The paint will be purchased through a private fund, and the labor will be provided by the county jail prisoners. This story indicates two points: first, there are people in the community seeing the IOOF Hall as a crucial building in its downtown revitalization; and second, there are efforts trying to bring life back to this building rather than letting it deteriorate.

While well-intentioned, the appeal for improving only the appearance of this building has overlooked the basic premise that underlines change. A realistic analysis of how to save this building must relate to the community's current needs and their plans for the future downtown. The IOOF Hall is functionally obsolete, and it is not viable to return to its original usage. The local IOOF has stopped its operation. The fitness shop on the first floor was "not profitable", to quote the shop owner's words, and has closed the business. The only tenant left is a real estate office which only occupies a small corner of the first floor. The conclusion can be drawn that the best mode to preserve this

building is not restoration nor extended-use, but adaptive-use.

Being conservative externally more than internally, an adaptive-use design may enable this old building to keep up with the society through feasible and profitable rehabilitation.

<3> Community Needs Survey

Confronted with a community concerned about its environmental beauty and downtown rehabilitation, the author felt compelled to bring the proposal to the community's attention, and believed that an opinion and attitude survey about the project would serve at least two purposes: first, it helps the author gain information to make a more realistic proposal; second, it increases public awareness and moral support in the community.

- Survey Objective

To collect some essential information about the public opinions and attitudes in the community on the following subjects:

<1> Whether or not the building should be saved;

<2> New use(s) for the building;

- Survey Method

While many other approaches might be possible, the author chose a written questionnaire method for this survey. It facilitates the tabulation of data, and offers the possibility of reaching a large number of respondents. Once carefully designed, this method can eliminate much subjectivity from the survey.

- Building Questionnaire

There are two kinds of questions to be asked. The first are

factual questions that ask respondents to provide information about "years lived in community", "number of visits to downtown per week", "purpose of visit", "ever heard of" or "ever been inside" the IOOF Hall. The purpose in raising these questions is to obtain the information needed to categorize the respondents in order to further analyze their responses to the opinion and attitude questions. The rationale behind this is that the answers from the respondents who have "never heard of the building" shall be treated differently from those from the people who "have been inside" the building.

The opinion and attitude questions deal with feelings, beliefs, and ideals, hence providing a basis for understanding the respondents' reactions. These questions have been stated as clearly and simply as possible. To avoid raising false expectations, the academic nature of this survey is emphasized in the cover letter.

There are two parts to the opinion and attitude questions. The first part asks whether or not to save the IOOF Hall, and why. Questions are raised with three aspects of concern: "in terms of the history", "in terms of the physical location" and "in terms of the architectural quality" of the building. In addition, blank space is provided for the respondents to list the other concerns they think are important about their choices to save the building or not. The second part is about how to save the building. This includes questions about what would be the most desired new use(s) for the building, and a list of possible new uses is provided by the author in random order. The respondents are asked to check

those that they think are appropriate. Blank space is provided for them to indicate any possibilities that are not on the list (see Appendix <1>). The last question asks how the remodeling work might be best accomplished. Two options are given: "to retain as much as possible of the original character", and "to contrast with the old to reveal the change".

- Sampling

The target sample of 80 families are chosen selectively from the local telephone directory with the assistance of the Garnett Chamber of Commerce and the Anderson County Economic Development Committee. These families either reside inside or close to the downtown area (within a radius of five miles from downtown). They have different backgrounds in terms of family-size, occupation, income level, and lifestyle. In each survey questionnaire mailed out, space has been provided for each family member, in addition to the head of the household, to express opinions about the proposal. These families are expected to represent the community.

- Results

There are 61 households who have returned the survey forms 40 days after they were sent. Responding ratio is $61/80 = 76.25\%$.

The survey results provide an informative source of opinions and attitudes about the following subjects:

<1> Whether or not the building should be saved: There are 59 households out of all the responding households (ie., 59 out of 61, 96.72%) who answered "yes" to all three questions raised about this subject. Forty-two families provided very detailed reasons of why

they think the building should be saved.

<2> New Use(s) for the building: There are 57 households (57/61 = 93.44%) who have checked their choices of preferred new use(s) for the building and/or listed the one(s) that are missing on the list. Some of these even addressed the reason(s) why to choose the use(s). The following table lists the new uses that were provided by the responding households. The frequency number describes the number of households that recommended each use.

New Use Name	Frequency Number	Remarks
Cultural Facility	34	#
Community Center	29	#
Recreational Facility	17	#
Retail Facility	10	#
Office	8	#
Residential Facility	4	#
Theater/Cinema	4	*
Restaurant	2	*
Youth Club	2	*
Crafts Emporium	1	*
Governmental Facility	0	#
Medical Facility	0	#

"#": on the list provided by the author; "*": recommended by the respondents.

<3> Remodeling work: There are 53 households (53/61 = 86.88%) who have checked "yes" to the option of "retain as much as possible of original character". The comments about the choices for the first option are categorized by the following aspects:

- a. "Nostalgia factor", ie., "love old", "meaning", "memory", etc.;
- b. "works for the small town image";
- c. "add character and charm to the downtown";
- d. "fit with the surroundings".

There are only two households (2/61 = 3.28%) who voted on the option of "to contrast with the old to reveal the change". Their comments are that remodeling work should aim at modernizing the old building for the new uses. Their desired best uses were retail and residential facilities.

For the question asking preference for locating desired use(s) in the existing building, comments varied significantly. Some people suggested locating retail facilities on the first floor, offices on the second floor, and community room (or meeting hall) on the third. Some suggested putting a community room (or recreational facility) on the first floor, and a cultural facility on the second. Others put a big question mark on the use of the third floor, and also indicated that a certain amount of work needed to be done to the third floor exit problem before any use to be possible.

<4> Proposed New Use for the IOOF Hall

The results of the community needs survey suggest that the most desired functional use for the future IOOF Hall is a cultural/recreational center for the whole community. It will house activities such as meetings, performances, exercises, games and exhibitions. There seem to be many reasons for the community to call for such a usage.

First, such a facility is lacking in the community. Garnett has now a public library (on Fourth Avenue) which also houses the Walker Art Collection; the Anderson County Historical Museum (at Fifth Avenue and Main Street) which records the historical development of the county and town; a senior center (on Fifth Avenue and west of Oak Street) which is a place for old citizens to meet. There is not yet an indoor place in the community where people, especially the young, can go for recreational AND cultural purposes. There is not yet an indoor theater. Several households have written down such requests as, "we need a theater", "there should be a place for our local band to play", and "we would like to see a large meeting room".

Second, the location of the building makes this use possible and necessary. As mentioned earlier, the IOOF Hall is located right inside the downtown area, at the cross-section of Oak Street and Fourth Avenue. It is an ideal place for a cultural/recreational center. The downtown area should attract not only the business person and shopper, but also the old and young, high schoolers and dowagers - in short, the whole community. A new

cultural/recreational center will add this social dimension: let the downtown be a pleasant, enjoyable place to go AND stay. The downtown has this opportunity. It has been a unique pedestrian-oriented district, as compared to the auto-oriented shopping strips along the highway. It ought to emerge as the community's social focus.

Third, the spatial structure of the existing IOOF Hall has the potential of being renovated for this usage. Almost 78% of the respondents have gone into the building, and have known about and indicated these potentials. The fact is that the building has two large theatrical rooms: one on the first floor and one on the third floor, both of which have a stage-like space where performances can be held. These two rooms can be renovated to house major community events and film showings. The second floor has two rooms, both of which have beautiful views of the Courthouse Square, and can be used as reading rooms or game rooms, or as offices.

Last, the overall present condition of this building makes it feasible for renovation. It is structurally sound. Most of its exterior and interior remains in "good" or "moderate" condition. It is one of the tallest and oldest structures in downtown Garnett. It has distinctive architectural details that are worth saving for the historical and cultural heritage of the community.

<5> Objectives of Project

The author sets forward objectives after the field investigation, survey study and other research findings.

The major objective of this project is to provide a cultural/recreational center that will inspire and enhance the social integration and cultural enrichment for all citizens of Garnett. The center will provide space and facilities for local art and craft displays, community assembly, and games for teenagers and entertainment for the elderly. The center will ensure efficient operation, provide flexibility of space, be direct and easily understood in arrangement, and provide an environment that is friendly, intimate, and pleasant. The center will be a live, vital place in which the discovery of ideas becomes exciting.

The second objective is the preservation and adaptation of the existing IOOF Hall and the design and construction of new facilities in a manner appropriate and respectful to this late 19th century building.

Third, the project aims to contribute to revitalization of the downtown area. The Center will become an important place in attracting people to the downtown area. The success of the project shall bring about a radical improvement in people's physical perception of the downtown environment.

Chapter 4

DESIGN PROGRAM

A major character in the programming process of an adaptive-use project is to establish realistic requirements for the new construction within the existing framework of the old structure. Both potentials and problems of the old structure should be identified definitively before any design decision is made, and this is therefore a part of the programming process. The allocation of the right amount of space to every proposed activity or function for the new design is closely associated with the reallocation of space in the old structure.

The programming process for the adaptive-use design for the IOOF Hall is also two-fold, i.e., establishing ideals for the new design while exploring whether these ideals can be achieved with the existing old structure. So, writing a design program for this adaptive-use project will not be accomplished without: <1> an in-depth study of existing conditions of the old structure; <2> identifying clearly the owner/user's needs and objectives; and <3> a careful exploration of the possibility that these needs might be satisfied with the old structure. The first two aspects have been discussed in Chapter Two and Three. This chapter will reassess the findings in Chapter Two, and translate the community's needs obtained in Chapter Three into specific facilities, with descriptions about the ideal physical setting and atmosphere, and see whether these facilities can be fit into the existing old

structure.

<1> Exploring Potentials and Problems with the Old Structure

4.1-1 Some Major Potentials

For the proposed use as a cultural/recreational center, this old structure has the following potentials in its spatial arrangement.

- theatrical space and large rooms

On the first floor, there is a large room of 1,050 square feet that had been used as banking space after the building was erected and as an exercise room for the former fitness shop before it was abandoned. The space to its north rises up 20 inches with wooden partitions which enclose three rooms. Potentially, if these partitions are removed, the space can be used as a simple stage.

On the third floor, the former IOOF meeting hall occupies 80% of the floor area. It is 1,550 square feet, the largest space in this building. Its floor to ceiling height is 14'-0". Since the

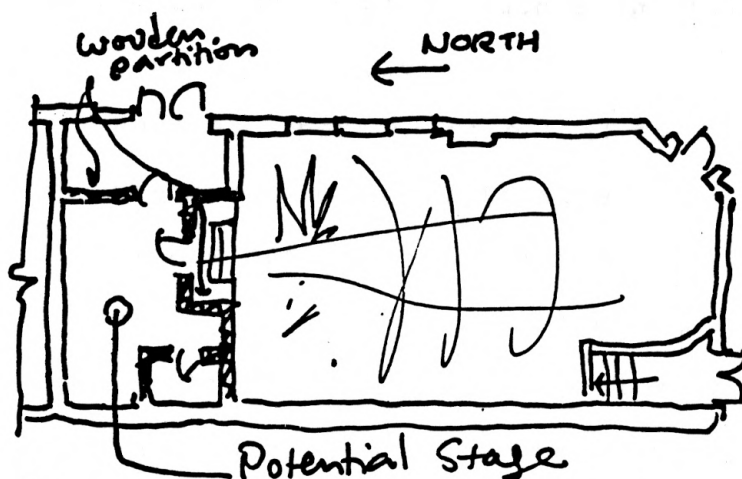

Diagram 4-1

IOOF organization has been the only occupant of this floor, almost all the original settings remain unchanged, i.e., the wooden platforms on the north, east and west side, the main stage at the south with pillars

and curtains, chairs against the east and west side wall, and even the symbolic murals on the wall that depict the images that are meaningful to the organization. Such a grand meeting room can be best used as a main assembling space for the proposed community center, once the circulation and exit problem are solved (more discussion in section 4.1-2).

- exhibition space

On the second floor, both the room size and the spatial arrangement are suitable for activities such as exhibitions, or

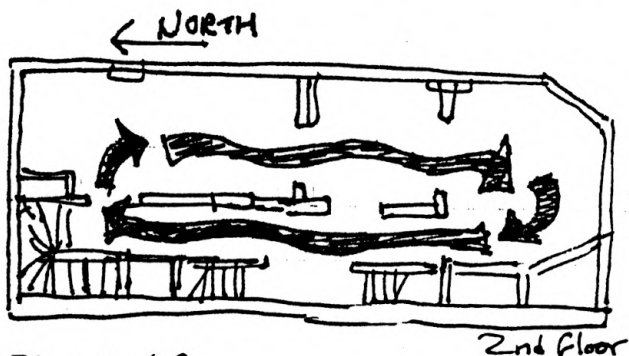

Diagram 4-2

2nd floor

arts and crafts show. There are two parallel circulation routes on this floor: the corridor and the flow through rooms (see diagram 4-2). These two routes make an enclosed movement that is necessary for the

exhibition space. Since the building itself has a long and thin configuration in plan, such a spatial flow is clear and definite.

- possible addition

Another important potential for this project is the possibility of extension to the north-side, i.e., to build an addition at the site where presently a one-story building sits. This building now houses a dry cleaning service which is also owned by the IOOF organization. While such a service can be moved to somewhere else, such a building site can accommodate enough facilities that are lacking in the old structure. Also, from the urban design point of

view, the streetscape will be more continuous when this small building gives room to the extension (see diagram 4-3).

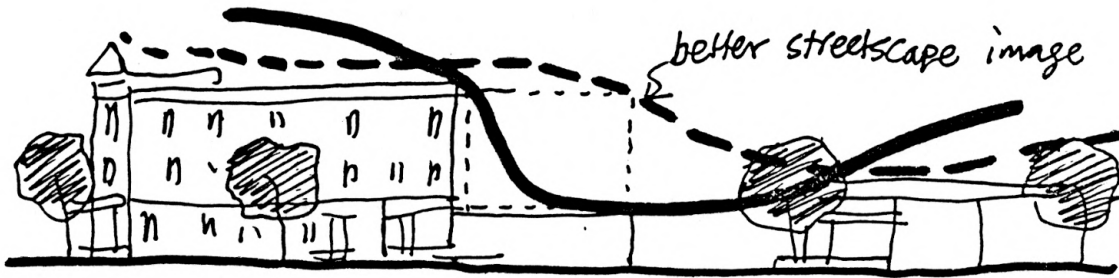

Diagram 4-3

4.1-2 Problems identified

Many problems emerge not only due to the fact that this old structure is now almost 110 years old but also due to the original function of this particular building.

- circulation

The first major problem with the existing building is

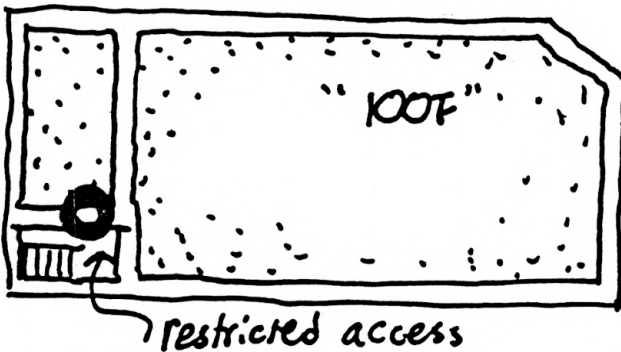

Diagram 4-4

circulation, both vertical and horizontal. There is only one narrow staircase connecting the second and the third floor. Both the riser and the tread dimension are far less than today's

standard, and the width of the stairs is only enough for one person going either down or up. The author found that one reason for this is because that the third floor was the secret IOOF grand meeting

hall. The access to it was highly restricted. Anyone who wanted to enter it had his/her identity checked and had passwords. Such a narrow staircase necessarily slowed down the movement to help the checking.

The connection between the first floor and the second floor is also inappropriate to today's standard. There are two staircases, but only the south one goes up from inside the first floor, the north one goes up from outside the building. The south staircase

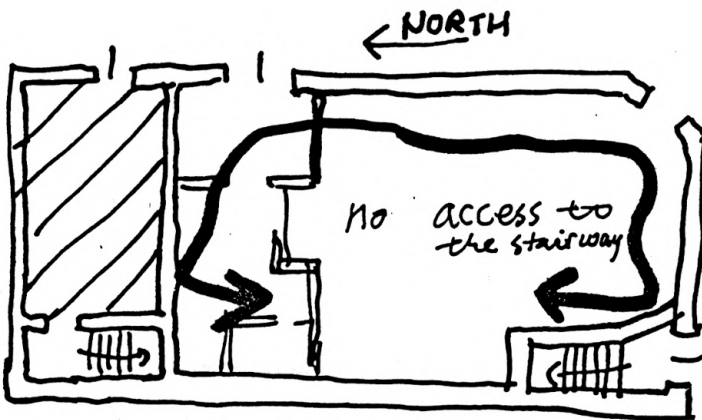

Diagram 4-5

served the separate entrance at the south-side that was used by the tenants on the second and the third floor. Presently, because the north staircase has been enclosed within the corner room, ie., the Pat Winfrey Real Estate

office, nobody can go up from inside the first floor to the second floor (see diagram 4-5).

- fire egress

Associated with the circulation problem, another problem arises with the consideration of fire egress. On the third floor, for example, there is no alternative fire exit route except that narrow staircase. The travel distance from the south end of the room to this staircase exceeds the limit of today's standard. On the second

floor, if the north staircase is used, the situation seems to be fine if a fire occurs. Still, doors need to be installed at both staircases to prevent the fire going from floor to floor.

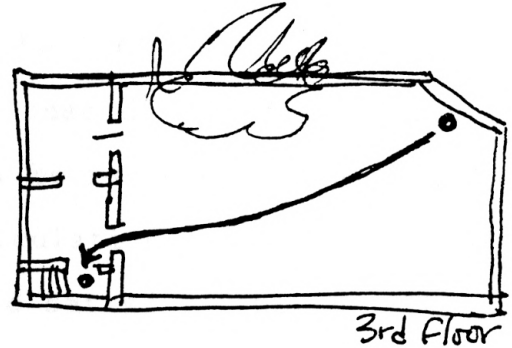
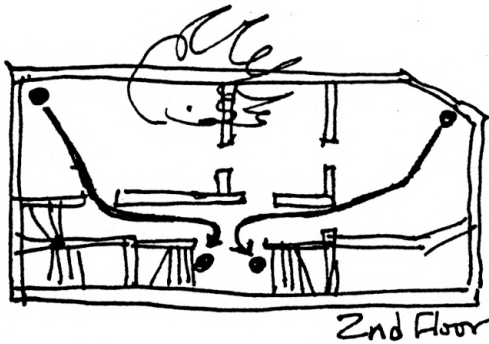

Diagram 4-6

- space limitation

While certain spaces are good for the proposed new functions, more rooms are needed for the necessary facilities, such as restrooms, storage, and office space. On the first floor, certain wooden partitions have cut the space into rooms that are too small to be used. Also the shape of these rooms thus created are also undesirable (see diagram 4-7).

<2> Three Steps in Programming the New Function

The next part of the programming process may be divided into following three steps. With each step, new ideals have to be supported by the existing old.

The first step is to create "activity centers" that are appropriate to the proposed cultural/recreational function, with descriptions of their atmosphere, nature of physical enclosure and settings. Second, to locate these proposed activity centers into the existing spatial framework of the IOOF Hall to see how well they might fit, and identify those that do not fit with clearly stated problems. These problems will be reviewed in Chapter Six to formulate design solutions. Good circulation and spatial flow is a key issue to examine how well the old satisfies the new. Third, to decide critical space size, proportion and area for these activity centers. An estimation of the needed space for each of these activity centers and the auxiliary individual spaces is given in light of the spatial availability with the existing building.

4.2-1 Activity Centers

One major need that people go to a cultural/recreational center for is to seek social interaction, cultural enrichment and physical fitness. The basic activities that such a center houses are community assemblies, theatrical performances, local arts and crafts exhibitions, games and entertainment for mental and physical fitness.

- community assembly

An ideal community assembly room is a place for the community to hold meetings, entertaining performances, and social banquets. It usually has a theatrical stage for public speakers, and entertaining performers to use. Although when compared with a formal theater hall, and is not as demanding in its atmosphere, the

room still needs to be acoustically sound. And viewing clearance requires normally a slope on the floor. The ceiling is normally at the height required by both the size of the room and for optimum acoustics.

- local arts and crafts exhibit

This is a place where both the historic and modern local arts and crafts works are exhibited. People may wander around these talented creations and get a sense of pride and inspiration. The resource for modern works can be drawn to the annual A.A.U.W. Square Fair which features an arts and crafts show from across the County. This indoor exhibition place can be an extension of the Fair and be year-round. Some of these arts and crafts works can

even be for-sale to help tourism. The purpose of this arts and crafts exhibit place requires its physical atmosphere being less formal than those of art galleries. A clear spatial movement is necessary, however, for its operation. There

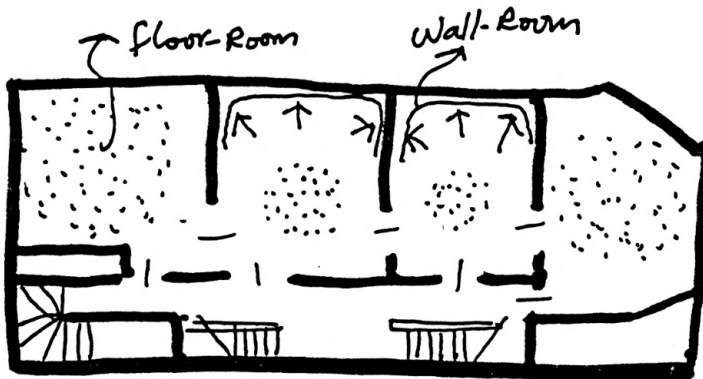

Diagram 4-7

should be both wall-rooms for paintings to be hung and floor-rooms for other types of works to be placed. While artificial light is necessary, natural light is also desired.

- games and other entertainment for mental and physical fitness

There are basically three types of activities in this category: that of the youth, that of the elderly and that for all ages. For the first, the place needs to be lively, exciting, and fast-paced. One may think of computer games or slot machines. The second type of

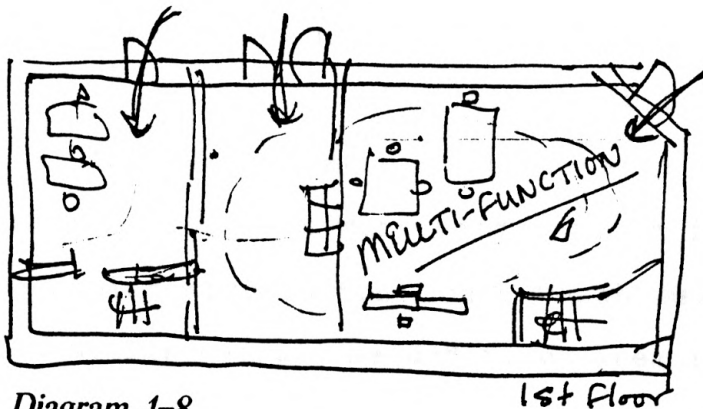

Diagram 4-8

1st Floor

activity turns towards that which is quiet and peaceful, such as playing cards or chess. The third type is normally a combination of the former two. This can include indoor ping-pong, weight-lifting or billiards.

Obviously, these three types of activities require different physical atmospheres. Generally, the first two types need to be more enclosed to prevent or protect the noise, while the third less so.

4.2-2 Are These Activity Centers Possible with the Old ?

- community assembly

When looking at the floor plans of the existing IOOF Hall, we have two choices of either the former IOOF grand meeting hall on the third floor or the former Fitness Shoppe on the first floor for the location of the community room. These are both large rooms and both have a theatrical stage. Comparatively, the former IOOF grand meeting hall on the third floor (floor area 1,497 sq ft, floor to

ceiling height 14'-0") is larger, while the former Fitness Shoppe (area 1,014 sq ft, floor to ceiling height 14'-5") on the first floor has easier access. And, the IOOF room has a better plaster ceiling and more enclosed walls on four sides. If the former IOOF grand meeting hall is to be used as the community room, circulation and fire egress problems must be solved first. One solution to this is to build the north-side addition.

* local arts and crafts exhibit

The best location for the arts and crafts exhibit is on the second floor. As mentioned earlier in section 4.1-1, there is an enclosed circulation route which makes up an exhibition spatial flow. The overall second floor area is 1,774 sq ft, including the lobby and the stairwells which accounted for 387 sq ft of the floor area. The floor to ceiling height is 12'-2".

- games and other entertainment rooms

If the third floor is to be used as the community assembly, and the second floor used for arts and crafts exhibits, the only floor left is the first floor. Potentially, the former Fitness Shoppe can

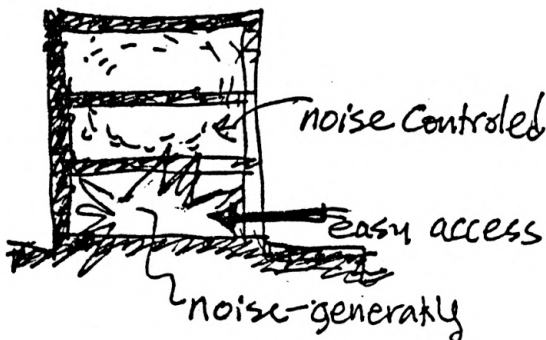

Diagram 4-9

be used as a multi-functional room that may house activities from dancing, indoor exercise, to film showing and meetings. The Pat Winfrey Real Estate office and the other small rooms can be used as small game rooms. The advantage of locating these activities on the first floor are for an informal setting and open to the public, with easy access. And it is also more reasonable for doing this since these activities are noise-generating and need less noise control (see Diagram 4-8 and 4-9).

4.2-3 A Spatial Estimation

Up until now, there has not been a good empirical study about the recommended floor areas for the facilities that a complete cultural/recreational community center normally provides. Also, for most adaptive-use projects no spatial estimation could be given without counting the existing spatial availability. In other words, even if there were a set of idealistic figures, for the adaptive-use project, they are not always applicable.

The following estimation of square footage for the proposed facilities are derived through a closer look of the existing structure, and will be used as references for the design phase.

Let us take the community assembly room, for example, to see how the estimation might be carried out. One meaningful figure to measure a community assembly room is its seating capacity. Given the overall population of the city of Garnett as 3,000, how many people should this community room accommodate ? This is a difficult question. Being it 10% of the population, is the figure 300 people? Or 20%, 5% ? We might set up a reasonable figure by

looking at the average household size, average age and the Garnett High School enrollment ... But, remember this is an adaptive-use project. The existing condition is where we have to start.

The overall floor area for the IOOF Hall is 6,580 sq ft. That gives each floor only 2,193 sq ft. At its maximum, the community assembly room can take 80% to 85% of one floor area (like the existing IOOF grand meeting hall does). That gives the possible floor area for the community assembly room 1,755 sq ft to 1,865 sq ft. With this square-footage range, the seating capacity will be around 90 to 95 people²⁰, about 3% of the city population.

Another factor that determines the estimation is the amount of space that an addition may provide. As discussed earlier, the only possible addition to this building would be at its north-side, on the site of the present dry cleaner establishment. The size of the site is 51'-2" by 31'-2", or 1,592 sq ft. For each floor, the addition may increase the space to 3,790 sq ft. But, it has to accommodate necessary auxiliary facilities, like restrooms. And, as already discussed in the last section, this addition has to first of all be used to solve circulation and fire egress problems. This leads to the next, yet more important, factor that determines the estimation: the code requirements.

The IOOF Hall is one of those existing old buildings that does not conform with the building code. It has to be brought up to the minimum requirements for the safety of its occupants. The following

²⁰. Considering the community assembly room as a simple forum room with no floor slope.

two aspects are considered:

<1> exits: The Code²¹ states that for all existing old buildings, every floor above the first story shall have access to at least two separate exits. The former IOOF grand meeting hall has only one exit, there must be another one.

<2> stair construction: The Code states that all required stairs shall have a minimum run of 11 inches and a maximum rise of 7 inches and a minimum width of 44 inches exclusive of handrails. At the same time, the Code also requires that a stairway serving an occupant load of 50 or more shall be not less than 44 inches in width. Now taking the second floor height 13'-10" of the existing IOOF Hall and the above requirements, we get through calculation the required minimum square footage for each stairway for the third floor of the IOOF Hall: 108 sq ft. With two stairways, it is 216 sq ft.

A similar calculation can be applied to the estimation of the square footage for the restroom for the third floor by considering the minimum number of toilets it has to provide for a community assembly room with about 100 seats. And, finally we conclude estimation of the size of the community assembly room: 1,700 sq ft to 1,850 sq ft, with seating capacity of 90 to 95 people.

The above estimation process is complicated yet rewarding. It evokes more detailed thinking that is helpful for the design phase.

²¹. UNIFORM BUILDING CODE, 1989 Edition, International Conference of Building Officials: Whittier, CA, May 1989. In Chapter Seven, more recent code requirements, such as contained in the Title III of Americans with Disabilities Act (ADA), are reviewed for design considerations.

<3> Proposed Facilities

The following lists the proposed facilities for the new cultural/recreational center for the city of Garnett. It is written based upon above two sections. It includes name and number of the functional facilities (ie., community room, game room) and the subsidiary services (ie., storage area, restroom), and the estimated amount of space for each of these. The estimation of floor area is made in consideration of all the possible effecting factors as discussed in section 4.2-3.

A List of Proposed Facilities for the Adaptive-Use of the IOOF Hall

name	number	total estimated floor area (unit: square foot)	possible location in the existing building	remark
community room	1	1,700 - 1,850	3rd floor	seating capacity: 90 - 95 people
exhibition & show room	1	1,250 - 1,400	2nd floor	
fitness room	1	950 - 980	1st floor	for all ages
game room	2	860 - 1,000	1st floor	one for youth and one for elderly
snack & bar	1	110 - 130	flexible	sell food, drink ...
lounge	1	440 - 460	1st or 2nd floor	where people may rest and socialize
lobby	3	980 - 1,000	one on each floor	a circulation and social space
restroom	6	800 - 950	two on each floor	one for women and one for men

(continued on next page)

(List of Proposed Facilities continued)

name	number	total estimated floor area (unit: square foot)	possible location in the existing building	remark
storage	2 - 4	180 - 200	flexible	
office	2 - 3	180 - 250	flexible	
mechanical room	1	80 - 100	flexible	
janitor's room	3	190 - 240	one on each floor	
circulation	stairways elevator	2,300 - 2,500		shall meet the minimum code requirements highly desired space, if budget does not allow, leave room for future installment
others		200 - 300		
total estimated floor area		10,210 - 11,210	total existing floor area: 6,585 sq ft total projected addition floor area: 3,625 - 4,625 sq ft	

Part Two: Design Study

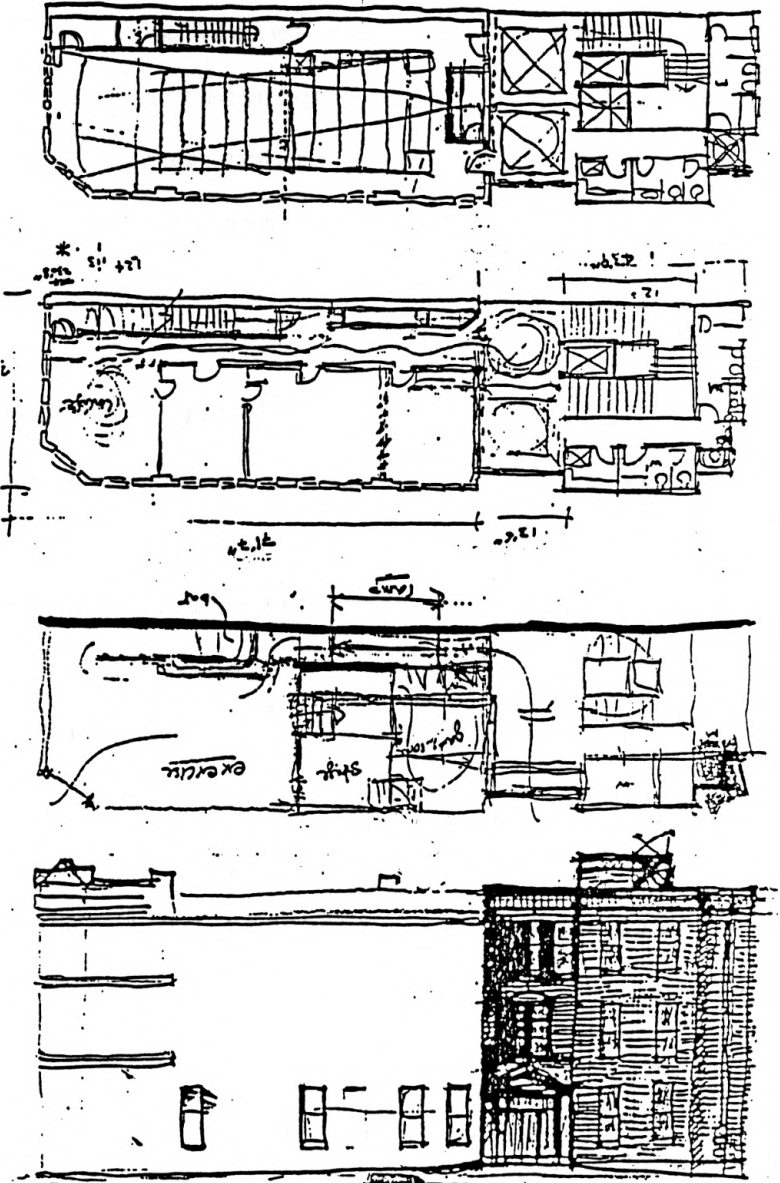

Chapter 5

PRECEDENT STUDY

As echoed in the dual purpose identified in Chapter Four, this project encounters two types of design problems: first, adaptive-use for downtown revitalization; second, adaptive-use for community usage. This chapter selects a number of examples of each type to review the lessons to be learned. Among these examples, some are similar to this project in context: also in small towns; some are similar to this project in program: also conversion for a cultural/recreational center. The situations of these old buildings before and after adaptive-use will be looked at. Issues like design program, design strategy and design technique will be examined in consideration of preservation and new creation. Special attention is placed on architects' exterior work and interior re-arrangement for the new facilities.

<1> Adaptive-Use in Downtown Revitalization

One important attribute to the connection of adaptive-use design to revitalization of old downtown districts has been the tax incentives which were established in the Federal Tax Reform Act of 1976. These tax incentives promote adaptive-use, viewing old buildings as assets, rather than tearing old buildings down and starting from scratch. At the same time, inflation has also given old structures an economic value that they did not have before.

The first American development to recognize the potential in

reviving the neglected downtown old buildings for merchandising and tourism was Ghiradelli Square in San Francisco, completed in 1964 (see figure 5-1). This project set a pattern by recreating a past, but if enquiring closely, one would find this had never actually

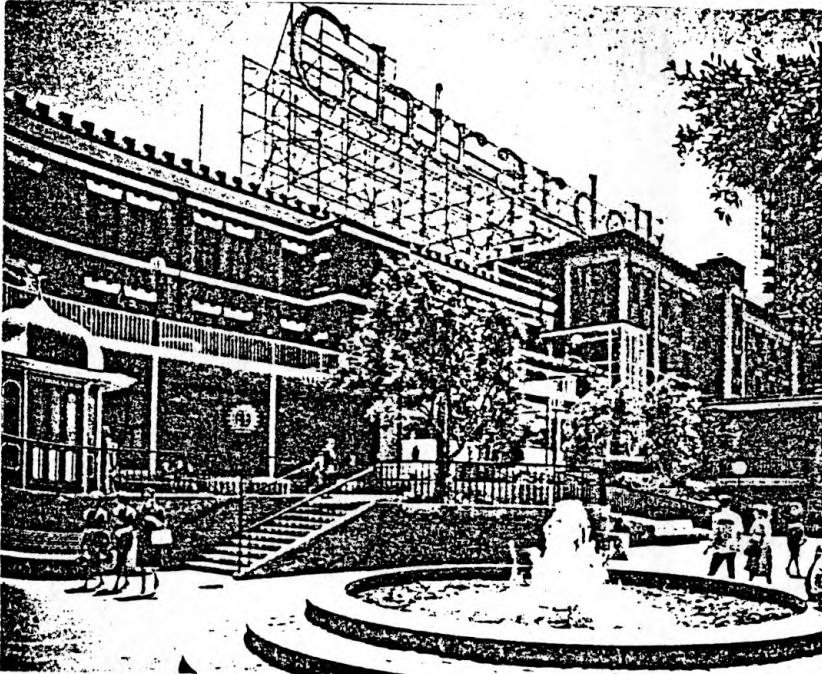

Figure 5-1 Ghiradelli Square, San Francisco

existed. A routine industrial building, with a few interesting architectural touches added, was transformed into a fantasyland of terraces and gazebos, and thus became an ideal home for a new kind of

special shopping center.

With most adaptive-use projects, architects strive to retain the original exterior of an old building while working with relative freedom within. The Paper Stock Co. Building at One Church Street in Nashville, Tennessee, is one such example, a single building in a row of old buildings in the downtown area (see figure 5-2)²². Prior to renovation, the 19th century facade was grimy but intact except for the entrance storefront. The architect's exterior

²². Source: Shopsin, William C., RESTORING OLD BUILDINGS FOR CONTEMPORARY USES, 1986, pp. 64.

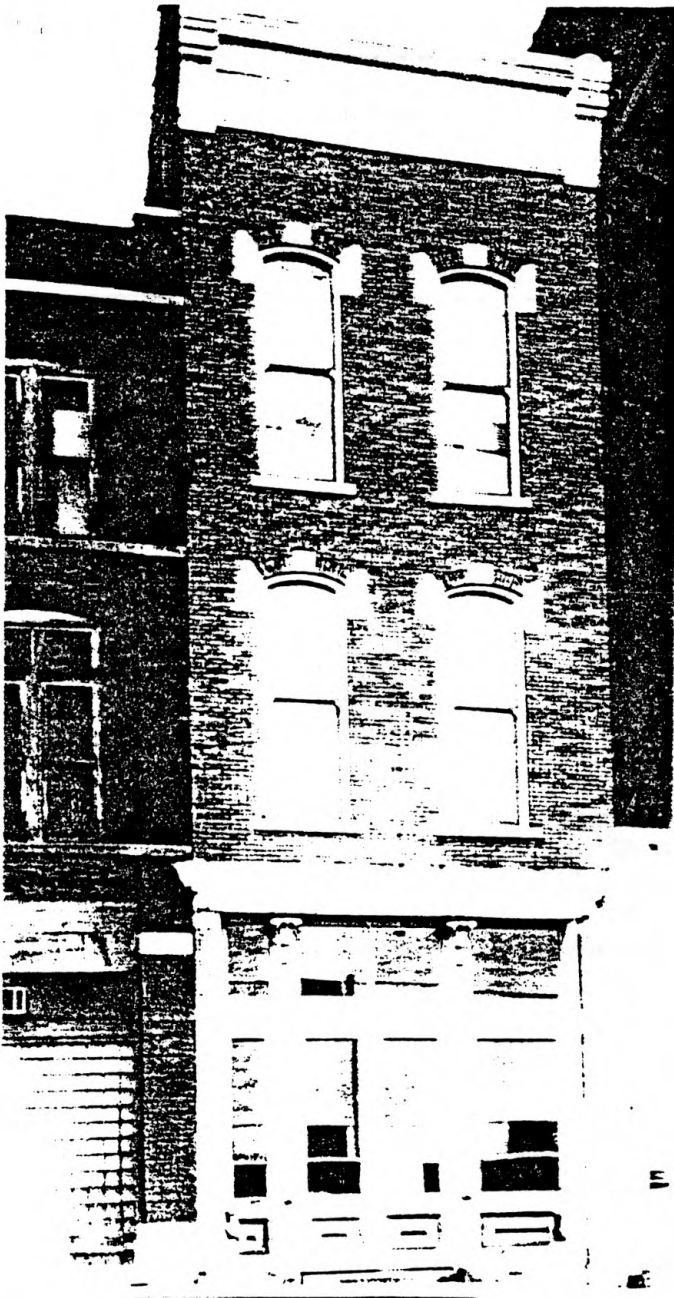

Figure 5-2.1 The Paper Stock Co. Building Project, Nashville, TN
(right above) facade (before renovation);
(right below & left) facade; interior (after renovation)

work included cleaning the masonry portions of the facade, restoration of the storefront, and painting the wood trim. Behind the small facade, a large modern office space was provided. Two new entrances were opened, respectively, to two other main streets that

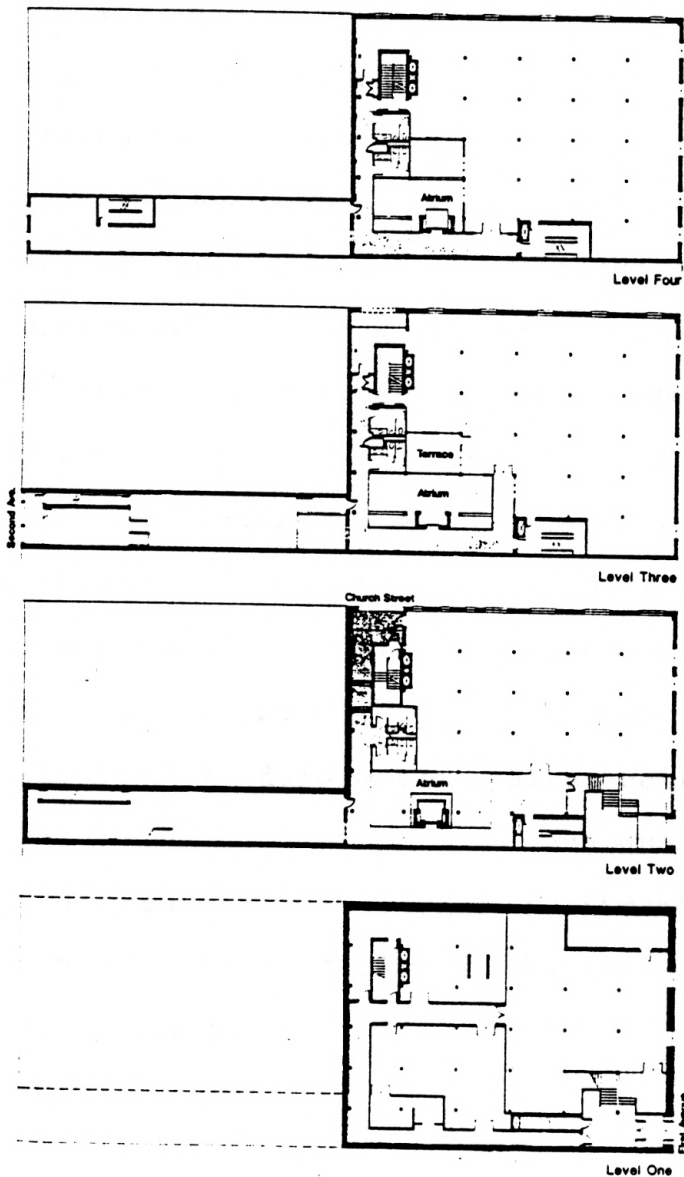

Figure 5-2.2 The Paper Stock Co. Building Project, Nashville, TN
- floor plans

that surround the building block. A new atrium which contains a glass-enclosed elevator was designed to bring daylight to a formerly dark windowless interior of the warehouse.

Adaptive-use provides a result with character impossible to imitate in new construction, and that character seems to be more fascinating when a building's old and new uses are more diverse. Unexpected spaces and details creatively re-used give them a poignant sense of life, of continuity, and of change. The Charles Street Meeting House in downtown Boston is a fine example. Its church exterior look was carefully maintained and renewed while its interior has been dramatically adapted (see photos and plans in figure 5-3)²³. The ground floor at the street level was divided into a series of small shops, most of which share a common vestibule. The former second level of the sanctuary now has a flat normal-height ceiling to house small office spaces. The new third floor was where the original round-topped arches of the side aisles started. The decorative plaster ceilings of the old sanctuary give the space a nice rhythm and unique setting. The topmost level of the architect's personal apartment is a small private library containing the framing of the upper-staged campanile of the former clock-tower.

²³. *ibid.*

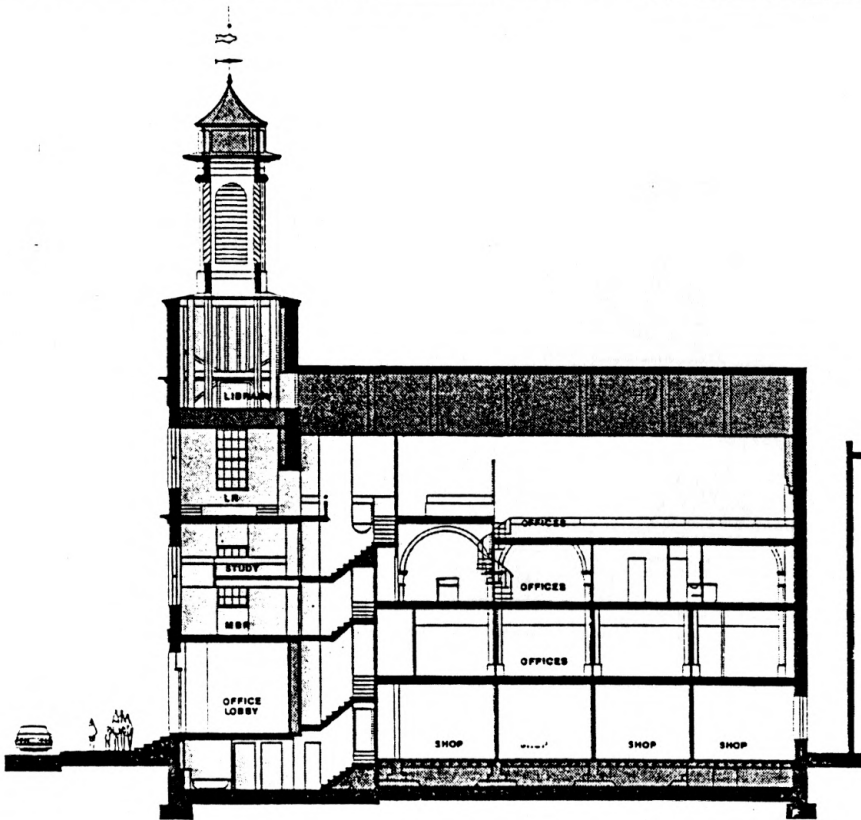

Figure 5-3 The Charles St. Meeting House Project, Boston, MA
(above) facade, interior; (below) section

<2> Adaptive-Use for Community Usage

In many American downtowns, adaptive-use has been closely related to the efforts of promoting the well being of community lives. As shown in the following projects, old structures are renovated for the general public for such uses as a theater, library, museum, exhibition space, arts gallery, and a church.

An award-winning project²⁴ in the city of Lowell, Massachusetts, completed in 1974, has almost a total mix of all the aforementioned facilities adapted within an old mill complex. This project has given the city a new cultural community center which focuses on the arts and ethnic cultures and houses arts workshops,

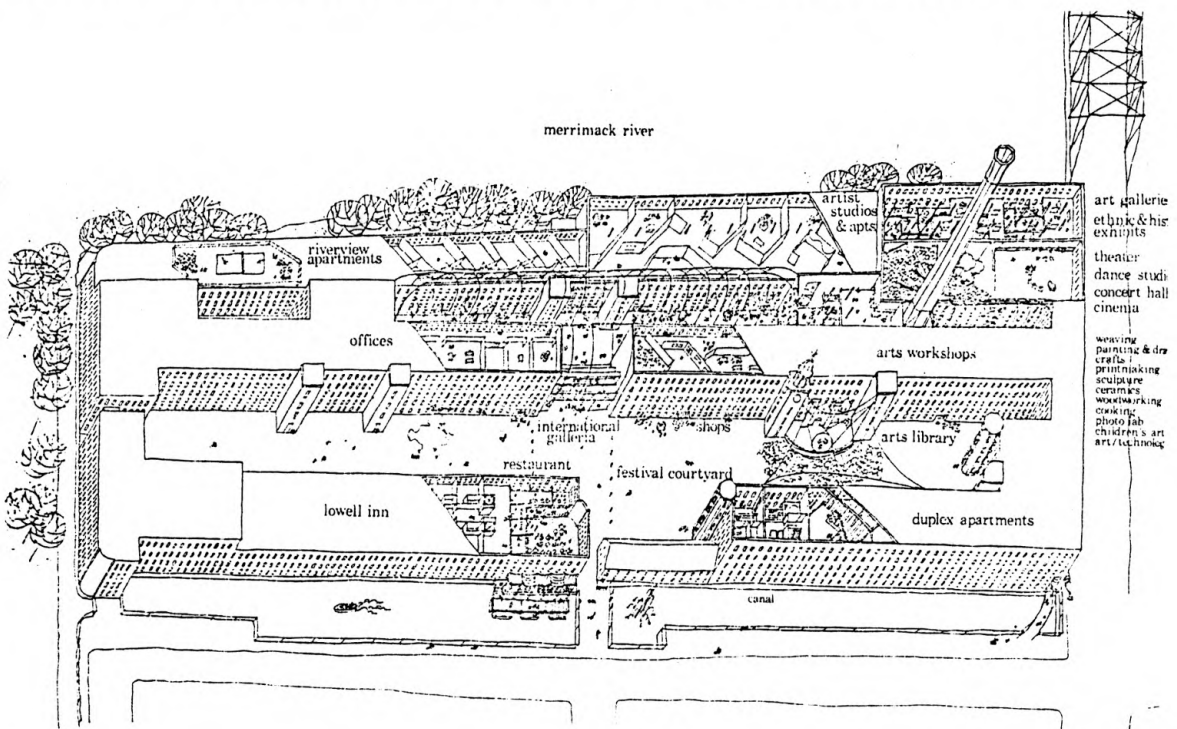

Figure 5-4
The Boott Mill Cultural Community Center Project, Lowell, MA

²⁴. Source: PROGRESSIVE ARCHITECTURE, January 1974, pp. 56.

exhibition spaces, a theater, restaurant, and an arts branch for the public library. As shown in the architect's drawing (see figure 5-4), even the two courtyards house various activities for use year-round. This tremendous mix of community services not only revitalizes these historic buildings but also lights up the night time downtown waterfront.

An almost countless number of old and obsolete structures could be adapted for community use. Even with complete changes in function, such as turning a carriage house into a place of public assembly, may entail much ingenuity in meeting code requirements. Such problems can be successfully overcome, as the next example shows.

The Newark Community Center of Arts in Newark, New Jersey, was converted from a former carriage house (see photos and plans in figure 5-5). With a tight budget and limited area, architects have provided rehearsal and performance space for music and dance. In dealing with code requirements, this building of 2,000 square feet was designed to accommodate two egress and adequate toilets. Although the roof and some of the masonry of the existing building had to be replaced, the original shell dictates the proportions of the adaptive-use design. Faced with a 2:5 plan proportion, the architects creatively introduced a diagonal stage permitting the width necessary for dance movement. A new roof structure echoed and reinforced the stage angle while a clerestory over the audience increased the sense of enclosure about the stage.

Another example of a simple, mundane building adapted for

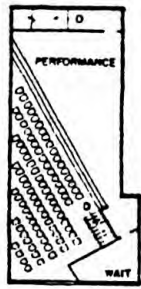
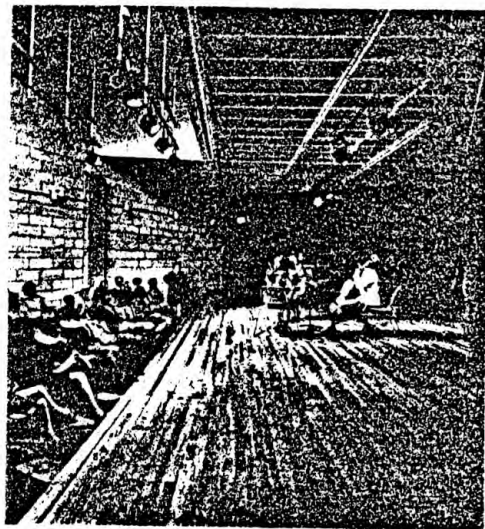
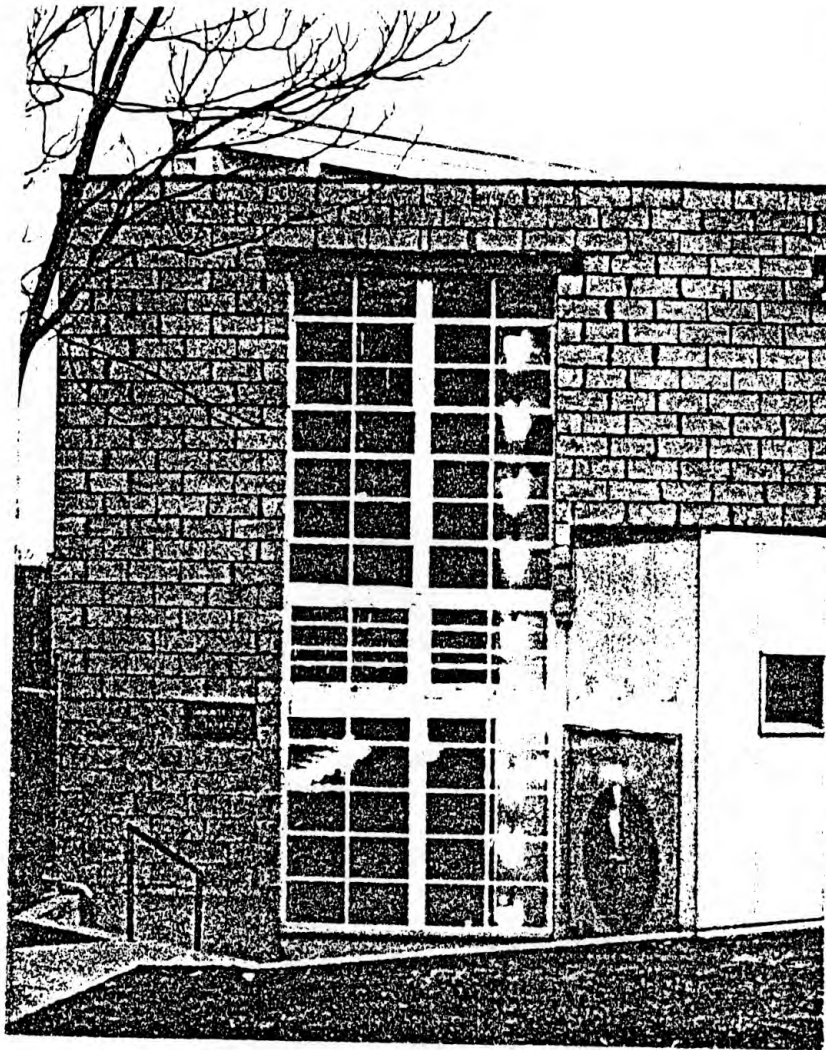

SECOND LEVEL

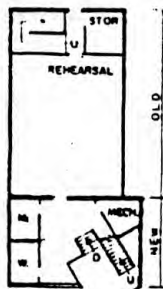

FIRST LEVEL

Figure 5-5 The Newark Community Center of Arts, Newark, NJ
 (above) facade; interior; (below) plans

community use was the Hope Community Center in Troy, New York. It was converted from a firehouse, built in 1885 at a cost of \$6,811.75. It was an obsolete building with an empty shell of brick and granite trim before the adaptation (see figure 5-6)²⁵. At the time, in Troy, there was a need for a space in which the elderly

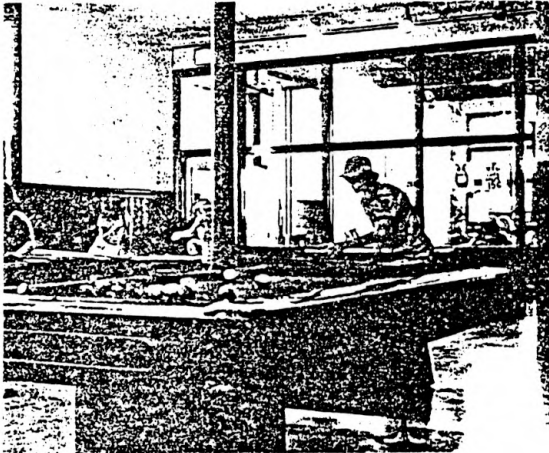

could meet, school children could assemble, and teenagers could be provided with recreational facilities. So, the building was rehabilitated to house pool tables, table tennis, and chess boards. A branch library was provided on the

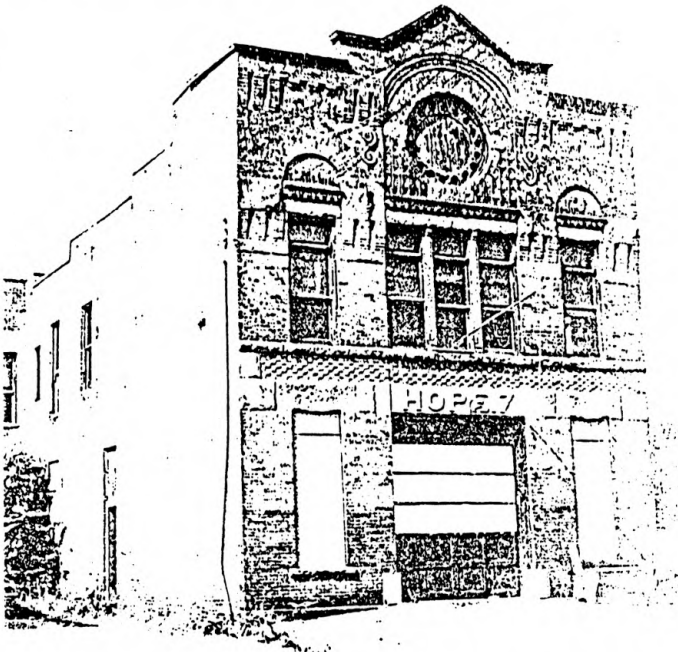

Figure 5-6 The Hope Community Center Project, Troy, New York (below) facade; (above) interior

²⁵. Source: URBAN DESIGN, Spring 1977, Vol.8, No.1

second floor with space remaining for a kitchen. Curb cuts and ramps were made for wheelchair access.

With some early adaptive-use projects, certain playful touches have been put on the interior and exterior, which might be considered as not respectful of the original building fabric. The Clinton Youth and Family Center on West 54th Street in Manhattan, New York, completed in 1970 is one such example. The building was once a police court, built at the beginning of this century. In adapting this building for the new use which called for a gymnasium, seminar and lounge rooms and offices, architects introduced new partitions and new floors to the former large courtroom. In both its interior and exterior, paint with graphics was boldly applied to walls, floors, ceilings, and even doors and windows. While most of the interior painting was done properly, attempting to create a sense of space and flow of movement, the exterior paint on the metal entrance looks rather violating the original building texture and details (see figure 5-7).

A different, better approach can be found with the adaptive-use design for the Institute of Contemporary Art in the Back Bay area of Boston. Formerly a police station, this is an old Romanesque twin-building, completed in 1886. The architects carefully cleaned up and restored the exterior, and eliminated any alterations that had no historic basis (see figure 5-8)²⁶. The original interior facilities, such as the 40 "drunk tanks", which served in its former function as a police station, were replaced with white-

²⁶. Source: PROGRESSIVE ARCHITECTURE, November 1976, pp. 55.

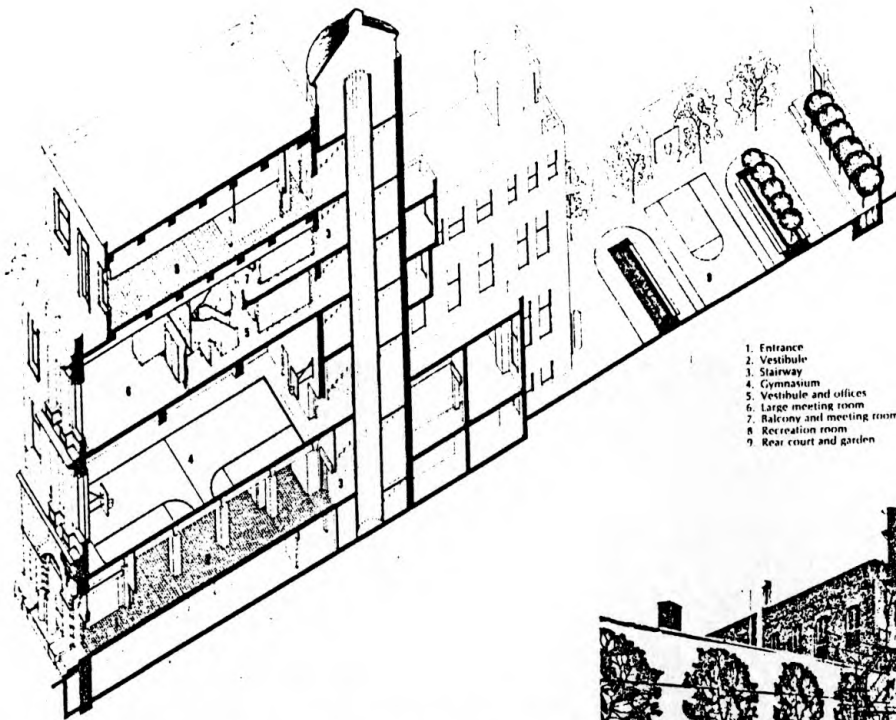

1. Entrance
2. Vestibule
3. Stairway
4. Gymnasium
5. Vestibule and offices
6. Large meeting room
7. Balcony and meeting rooms
8. Recreation room
9. Rear court and garden

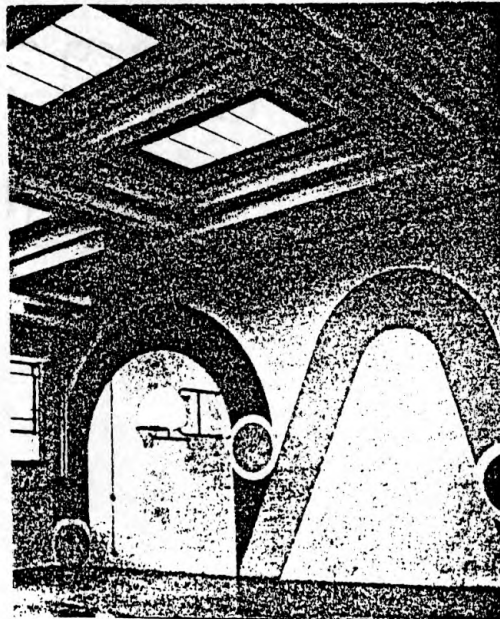
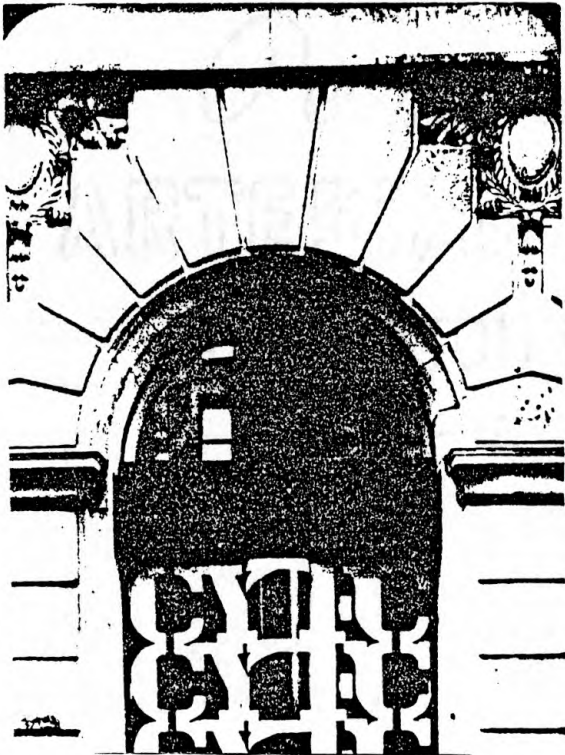
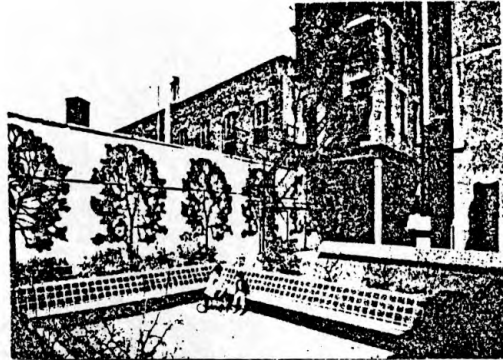

Figure 5-7
 The Clinton Youth and Family Center Project, New York, NY
 - (above) section; (below left) entrance;
 - (below right) interior and rear court

walled gallery spaces. Within a building measuring only 40 feet wide and 90 feet long, additional facilities were creatively inserted, including a loading deck, storage area, elevators, workshops, and an auditorium and offices. One key element which

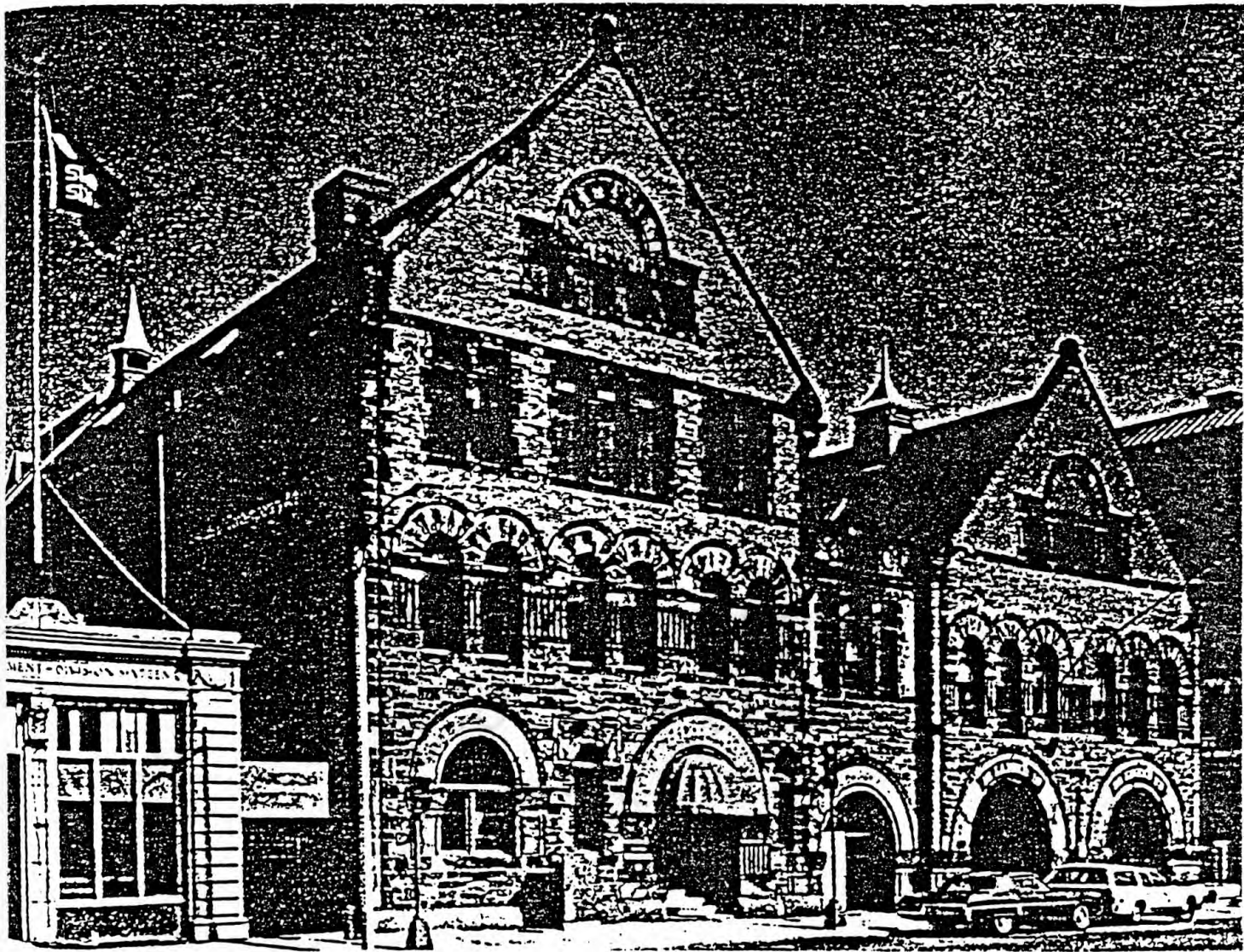

Figure 5-8.1 The Institute of Contemporary Art Project, Boston, MA
- facade (after)

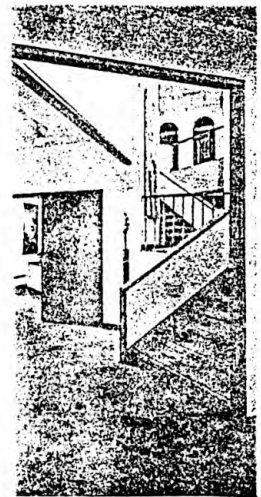
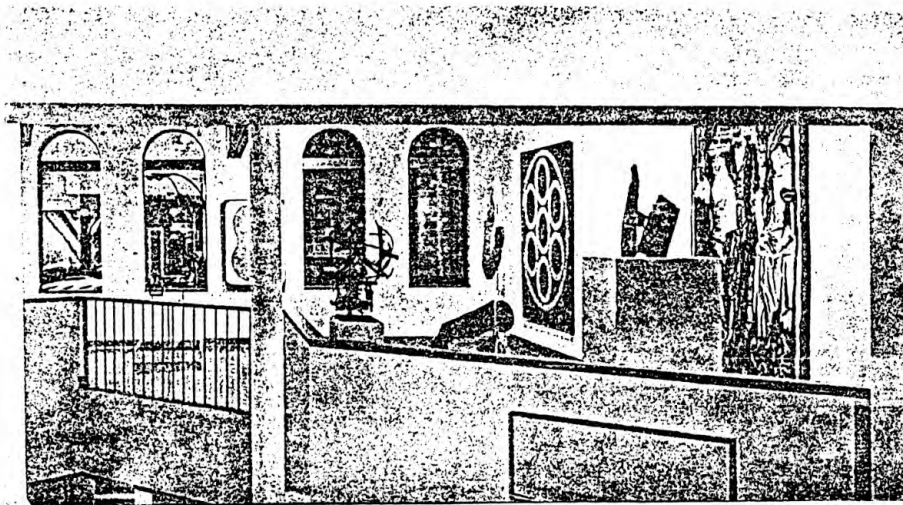
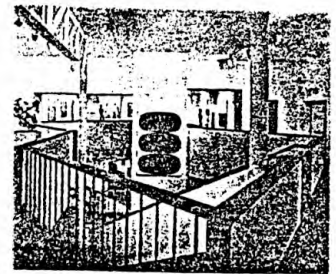
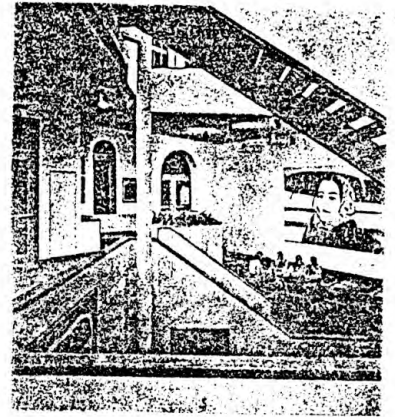
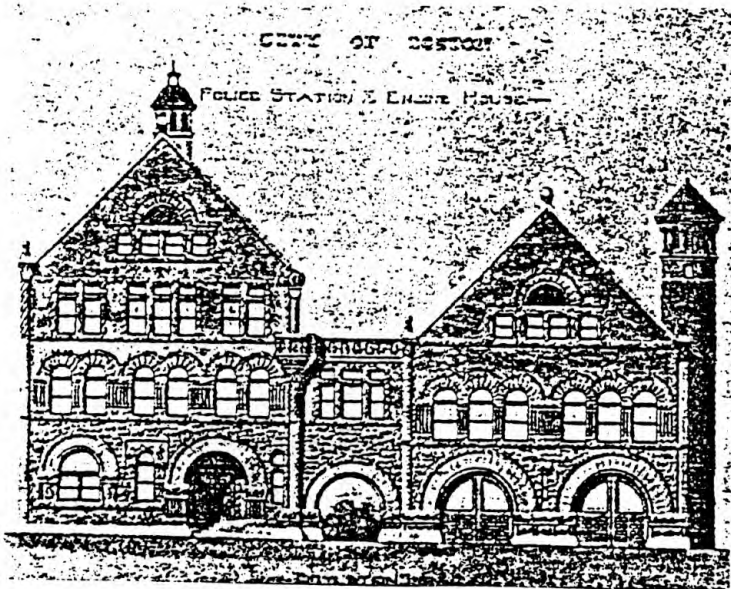

Figure 5-8.2 The Institute of Contemporary Art Project, Boston, MA (above right) original twin-building; (above left & below) interior

the architects introduced into this building was an open, three-story, split-level, and 45 degree-angled stairwell. This gives the small interior a sense of spaciousness.

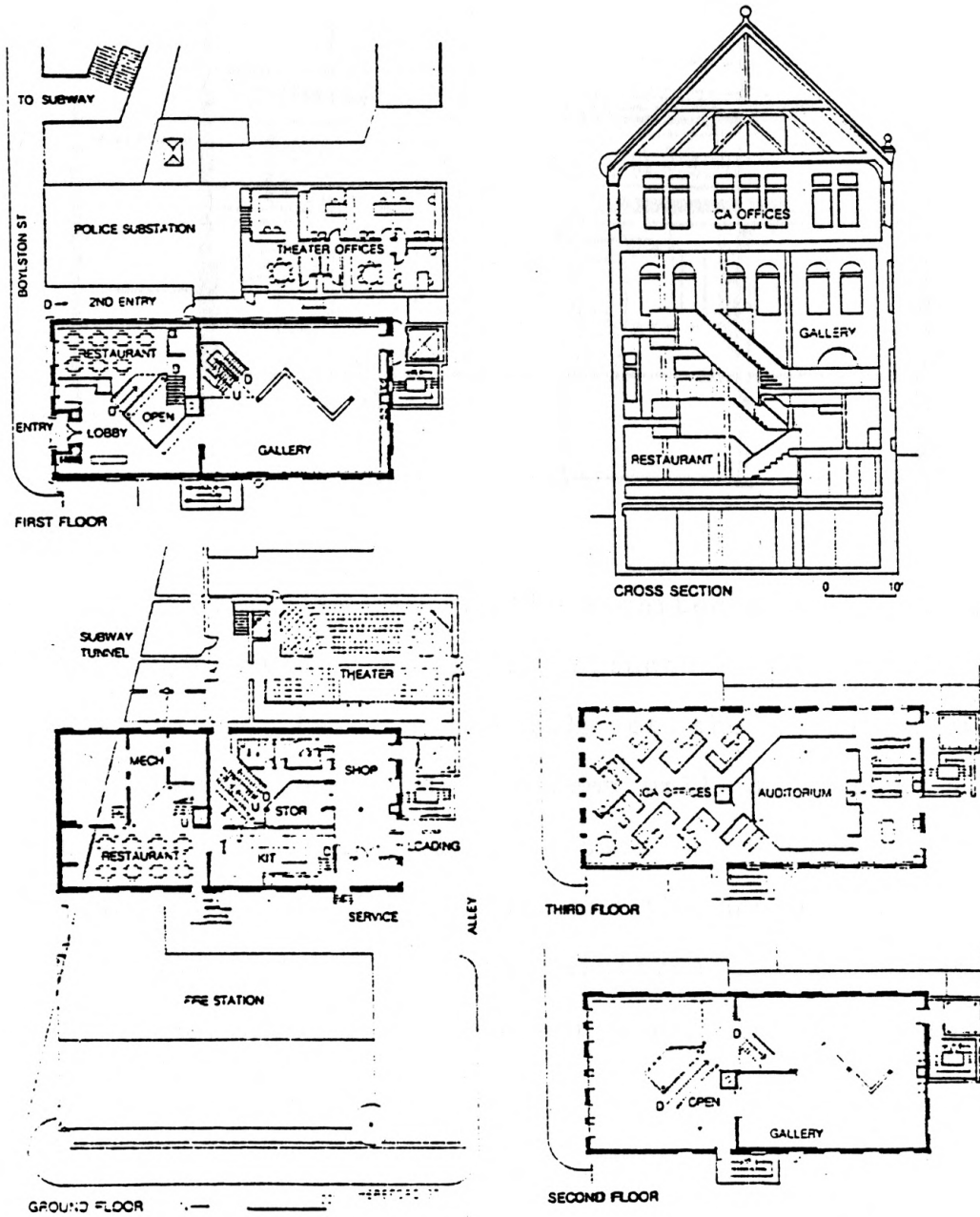

Figure 5-8.3 The Institute of Contemporary Art Project, Boston, MA (above right) section; (above left & below) plans

The Grace Episcopal Church and Community Center in downtown Chicago is an adaptive-use project successfully designed to "create

"within".

The original structure was a printing plant on South Dearborn Street.

The building

was to be a community center. The architects tidied up the exterior of this 130 year old church structure, and replaced damaged windows, wisely leaving the bulk of the street facade intact. Inside, however, a new oval screen wall was added on its second floor with an old brick shell around it. A nice contrast between the openness of the first floor and the enclosure of space on the floors above was created to reinforce reminiscences of Gothic ambulatories, transepts, and other traditional forms (see figure 5-9)²⁷.

²⁷. Source: ARCHITECTURAL RECORD, February 1987.

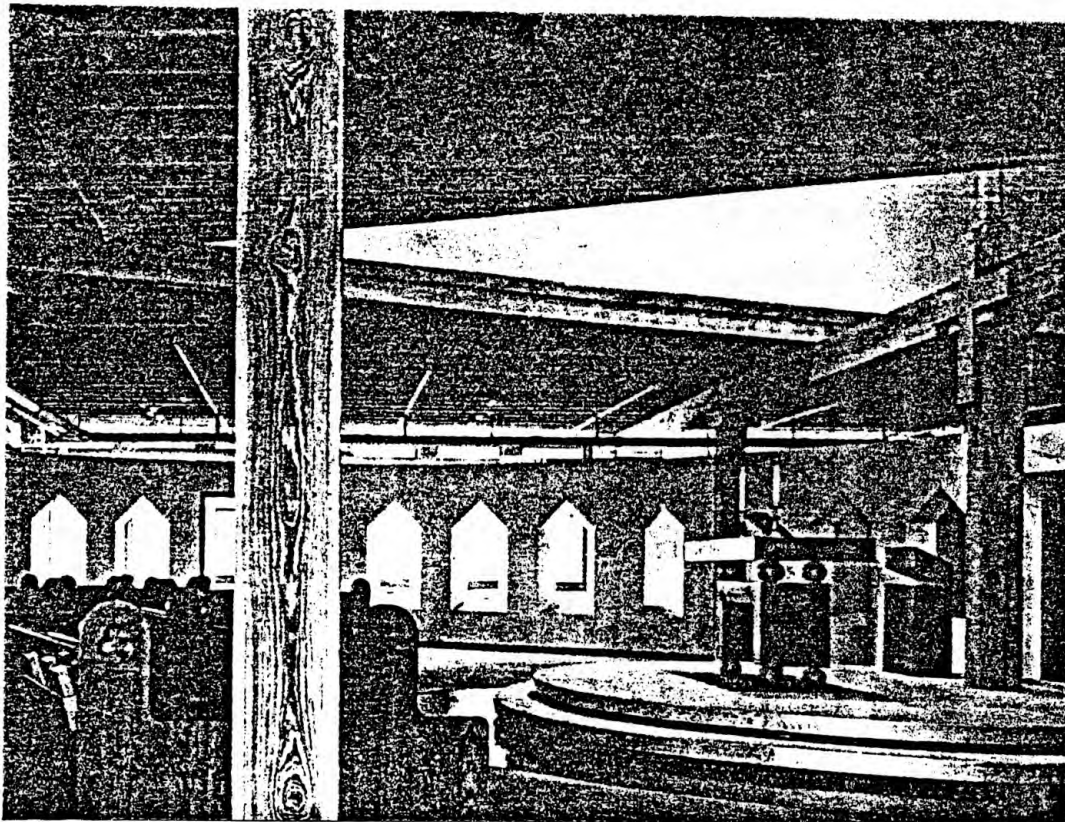
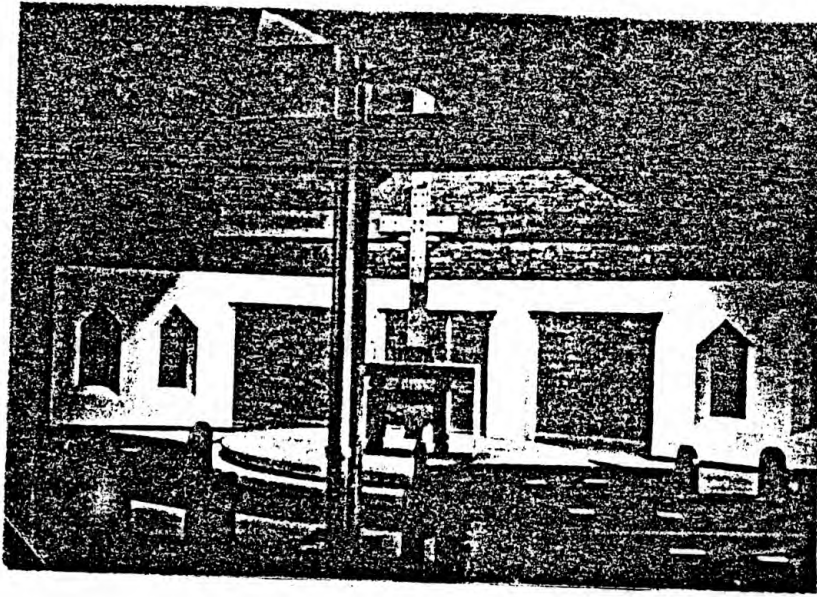

Figure 5-9
The Grace Episcopal Church & Community Center Project, Chicago, IL
- interior views (second floor, after)

Chapter 6

DESIGN STRATEGY

This chapter compares and evaluates three types of different design solutions frequently used in adaptive-use projects, in consideration with the particular situation of the existing IOOF Hall and the proposed program of this project, and sets forward the general strategy for design.

<1> Alternative Models

With most adaptive-use projects successfully completed in the past, three different types of design solutions have been used: "shell model", "fragment model" and "annex model".

6.1-1 "Shell Model"

This design solution is to keep the exterior wall and other associated structures intact while tearing down most of the interior floors, walls, and other structural and decorative features. New constructions are built within the original shell which ensures a complete single structure with original spatial pattern altered.

One example is the adaptive-use project of Whig Hall at Princeton University, N.J., by Grathmey-Siegel Architects (see photos and drawings in figure 6-1)²⁸. The old structure, built in 1893, has been the home of the Princeton debating society. The

²⁸. Source: Stanley Abercrombie GWATHMEY SIEGEL, Monographs on Contemporary Architecture, New York: Watson-Guption Publications, 1981. pp. 20.

renovation program called for additional facilities for public and university use. In order to provide 10,000 sq ft of area in a building that originally had only 7,000 sq ft, the architect built



new construction within the neoclassical shell. Four floors replaced the original three, and a new structural system was created independent of the masonry shell. While the front facade looks as it did in 1893, its side

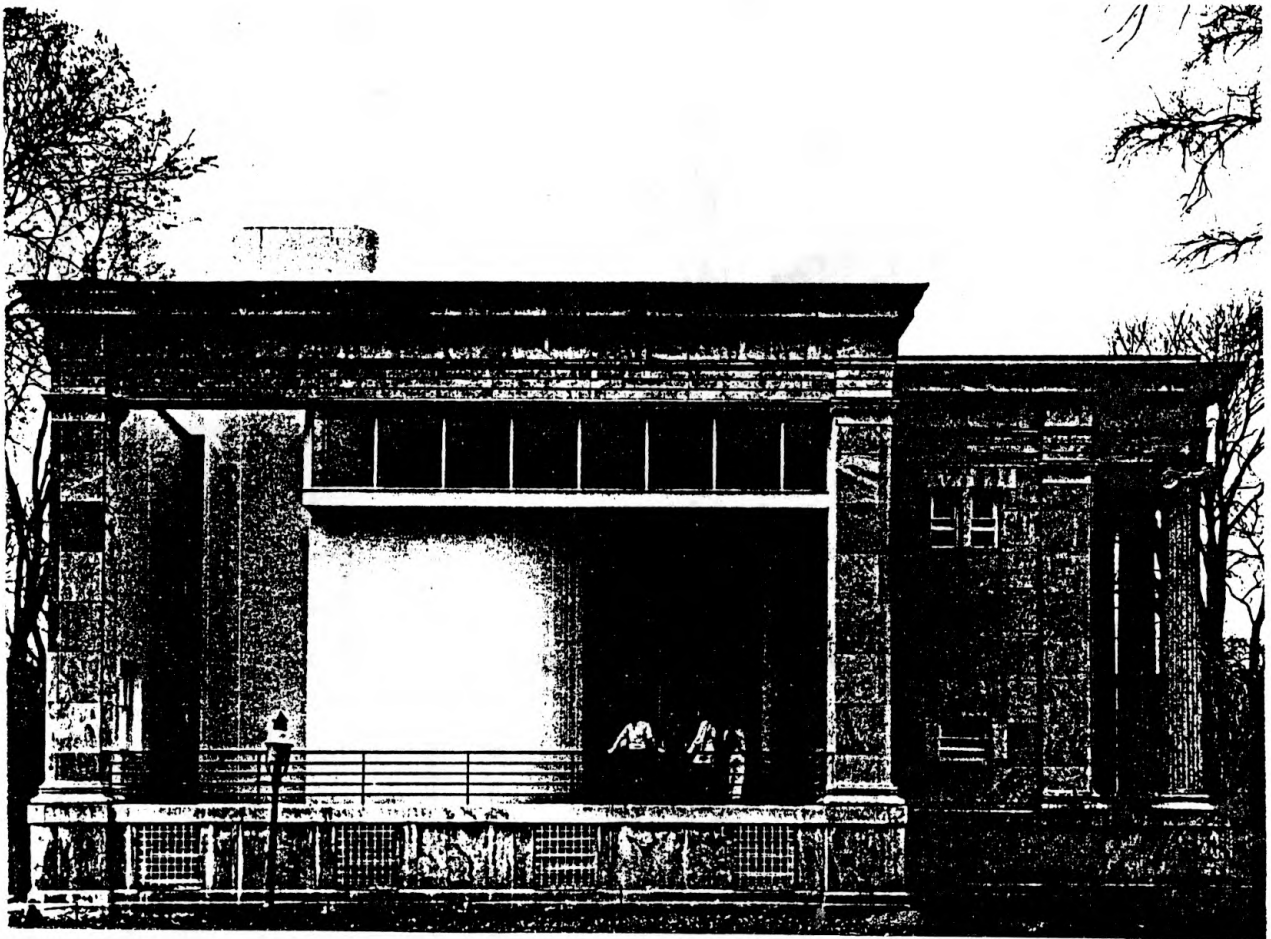

Figure 6-1.1 The Whig Hall Project at Princeton University, NJ. (above) model; (below) side facade.

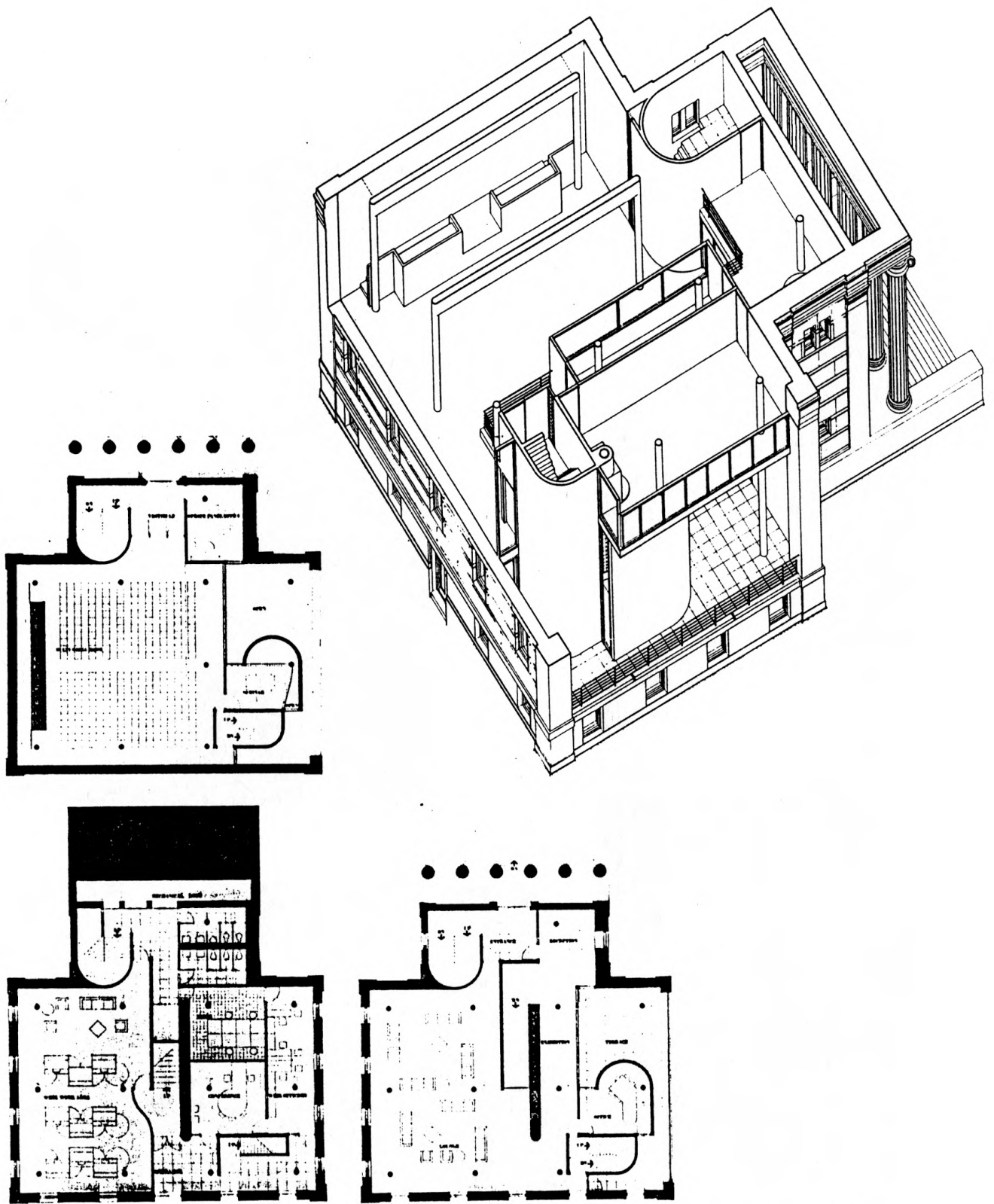

Figure 6-1.2 The Whig Hall Project at Princeton University, NJ. (above right) axonometric section; (above left & below) plans.

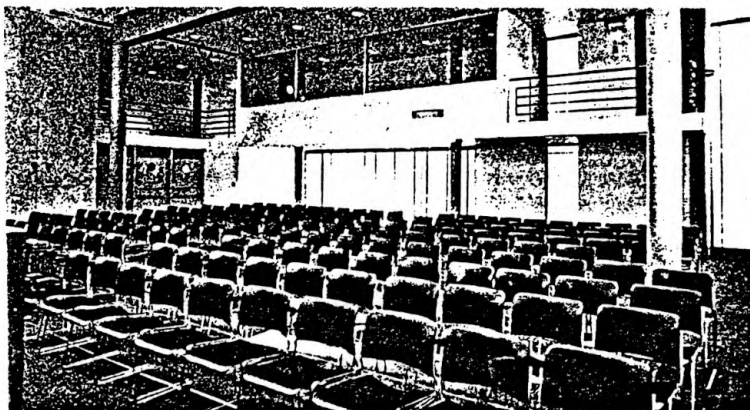
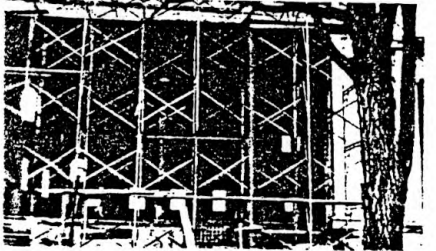
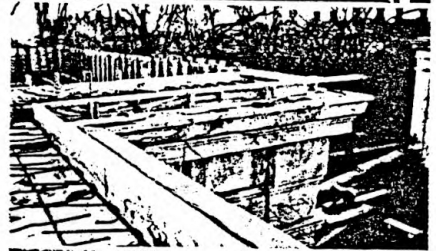
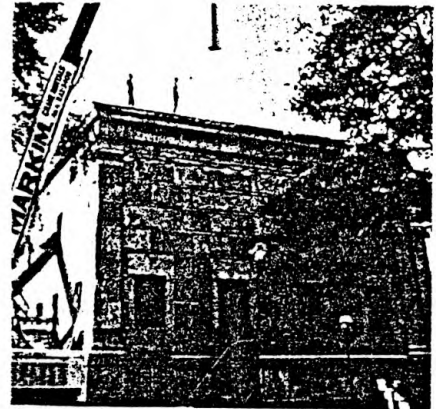
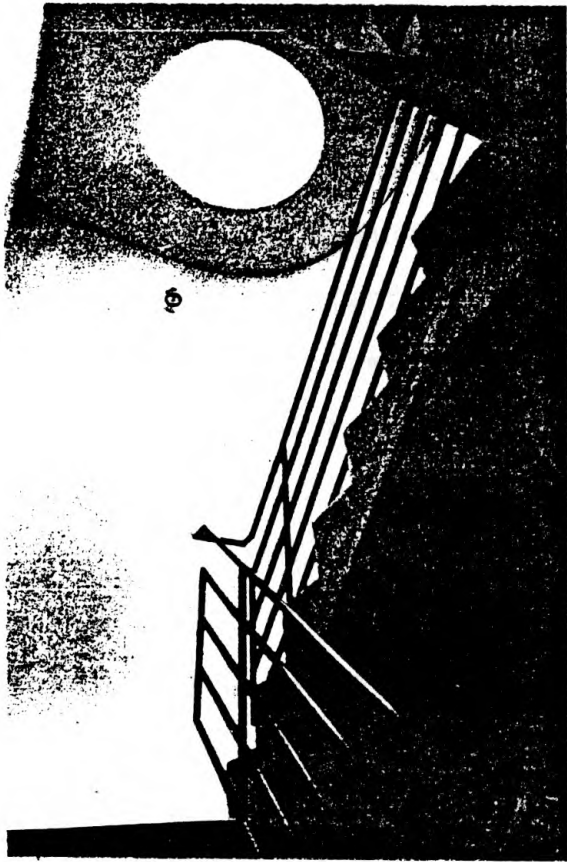

Figure 6-1.3 The Whig Hall Project at Princeton University, NJ. (left) interior views; (right) construction process

facade demonstrates the contrast between its classical and modern content. It is a compelling answer to the issue of degree in modification. In keeping a new dynamic life within an old shell, such a design solution may give full strength to a new function, show respect, and add another level of meaning.

6.1-2 "Fragment Model"

This design solution is to retain and/or restore parts of the exterior and interior features of the old structure, and build new constructions to replace others that are to be torn down. The original spatial pattern is altered with fragments of images of the old standing out in the new design.

A good example of this can be seen in Richard Meier's design for the conversion of an old stable building in Florence, Italy, into a modern art museum (known as the MOMA project, see figure 6-2)²⁹. In this adaptive-use project, only parts of the old structure were retained. The principle walls - the two facing the approach and the courtyard entry - were restored to maintain the historical character of the building. The new roof plane was lifted away from the existing cornice. The function of the old walls was revealed, and shown to be a screen. Old and new were related to each other through a studied compatibility of mass and scale, and through the use, for new floors and walls, of the same dark gray stone that made up the old building. Such a solution is not, as Meier put it, superficially paraphrasing the old in the new but rather distinguishing between them. Yet through subtle analysis of the

²⁹. Source: PROGRESSIVE ARCHITECTURE, March 1975.

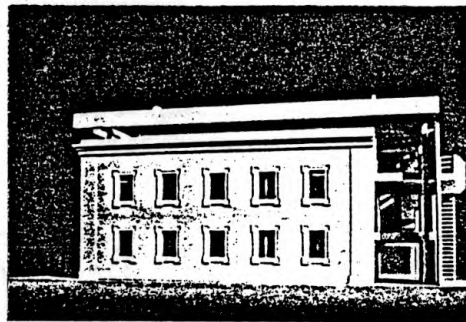
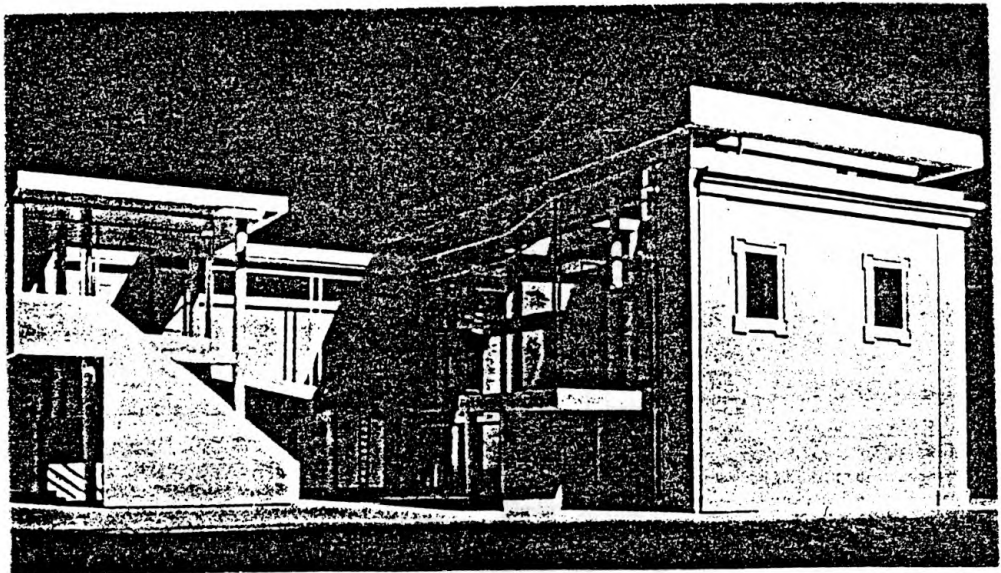

Figure 6-2.1 Meier's Design for the MOMA Project, Florence, Italy (left) old stable building; (right) model.

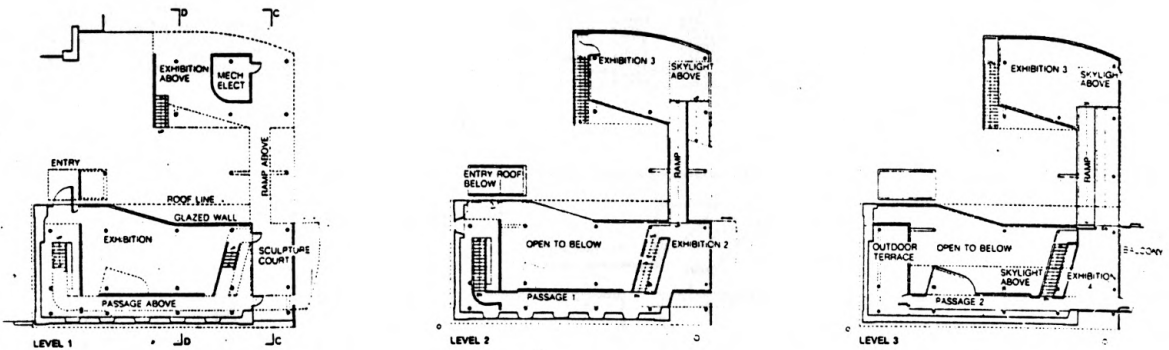
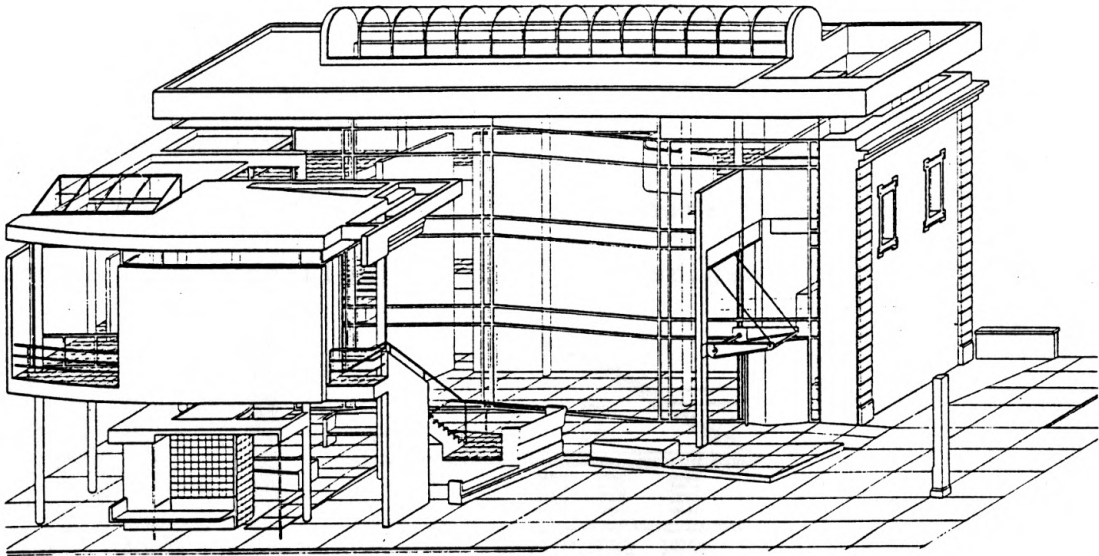

Figure 6-2.2 Meier's Design for the MOMA Project, Florence, Italy (above) axonometric view; (below) plans.

mass and scale of old and new, each is brought into a relationship of respect for the other, and each enhances the other with a force that could not have been possible otherwise.

6.1-3 "Annex Model"

This design solution is to repair and/or restore most of the exterior and interior features of the old structure, and build an

addition next to it to accommodate the functional facilities that are impossible to house in the old. The finished product will be two structures adjoined together. The old structure has its original spatial pattern remaining. The new is to be built to make up what is lacking in the old.

One such example is the Graff House project in Philadelphia, Pennsylvania (see figure 6-3)³⁰. The original structure, which was

built in 1776, where Thomas Jefferson drafted the Declaration of Independence, was restored with an addition attached for exhibits, storage, and film viewing spaces. The modern poured-in-place concrete addition, which was constructed at the

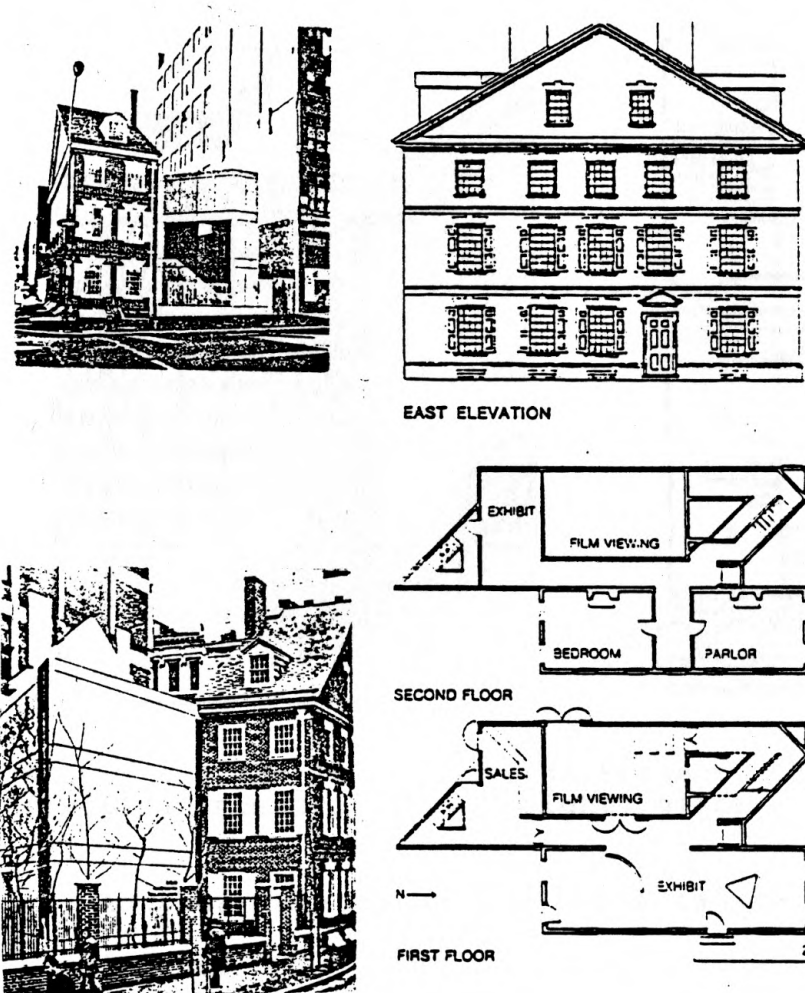

Figure 6-3 Graff House Project, Philadelphia, PA
(left) facades; (right) east elevation & plans

³⁰. Source: PROGRESSIVE ARCHITECTURE, April 1974.

west end of the site, maintains faithfully the cornice lines of the old building. It is a neutral, planar backdrop that emphasizes the presence of the historic Graff House.

Such a design solution can also be found with the Printing Press Project in Chicago, Illinois, which has turned an existing turn-of-the-century terminal building into a residential facility (see figure 6-4)³¹.

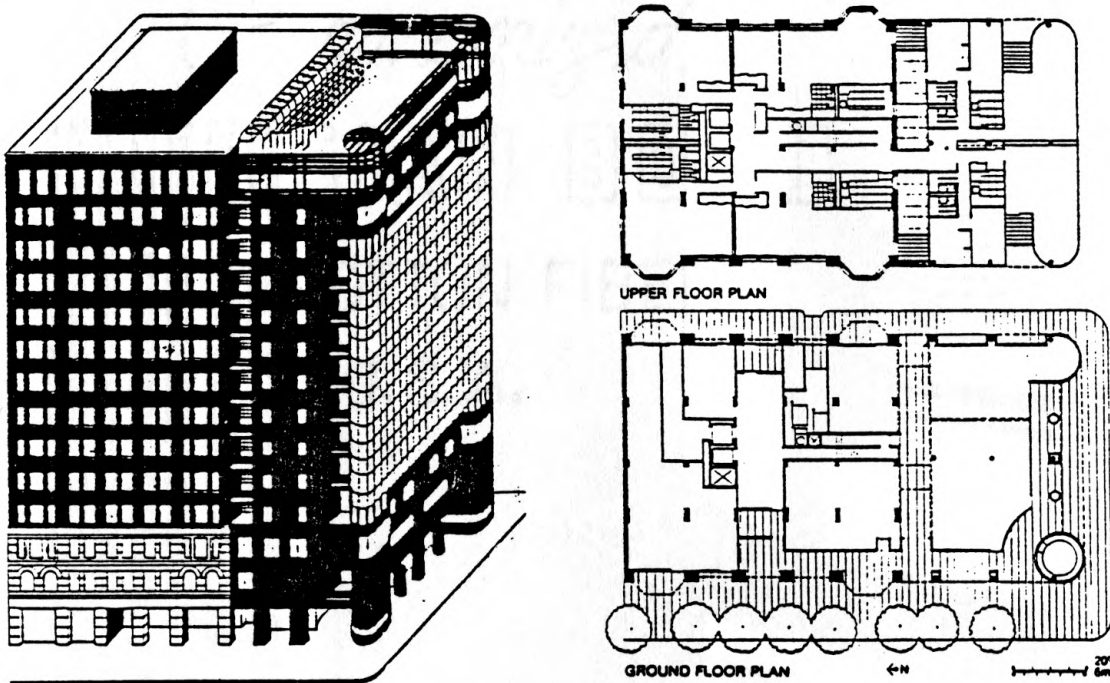

Figure 6-4 The Printing Press Project, Chicago, IL
(left) axonometric view; (right) plans

Another annex model solution is the Wainwright State Office Complex in St. Louis, Missouri (see figure 6-5)³². The old Wainwright building was designed by Louis Sullivan in 1890. The

³¹. Source: PROGRESSIVE ARCHITECTURE,

³². Source: MITCHELL/GIURGOLA ARCHITECTS, pp. 97

renovation design consists of re-use of the original building in concert with the addition of three L-shaped low buildings unified



Figure 6-5.1 Wainwright State Office Complex, St. Louis, MO
- perspective view

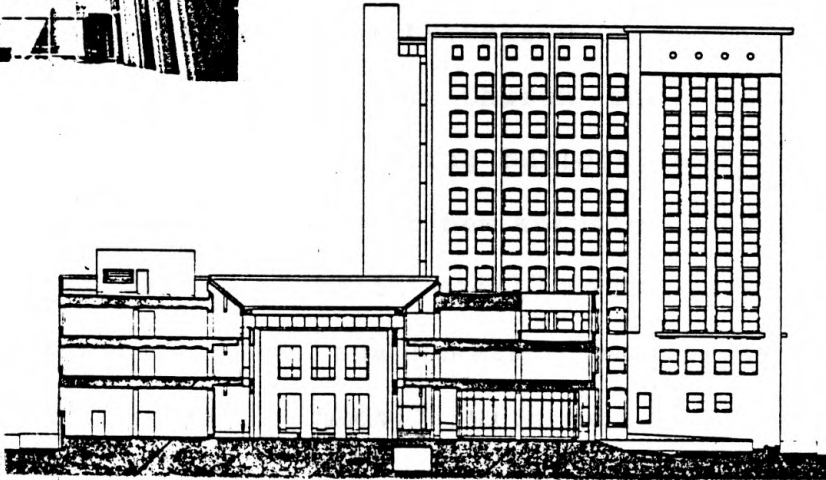
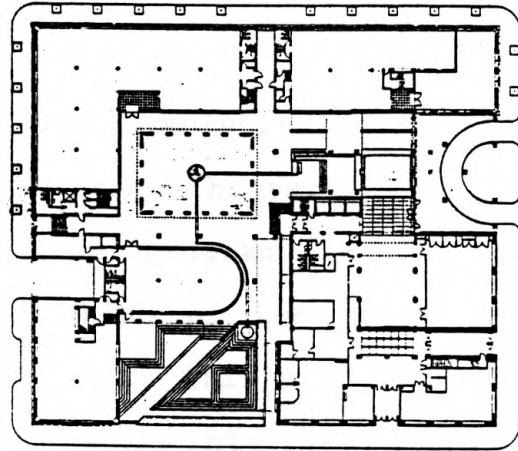
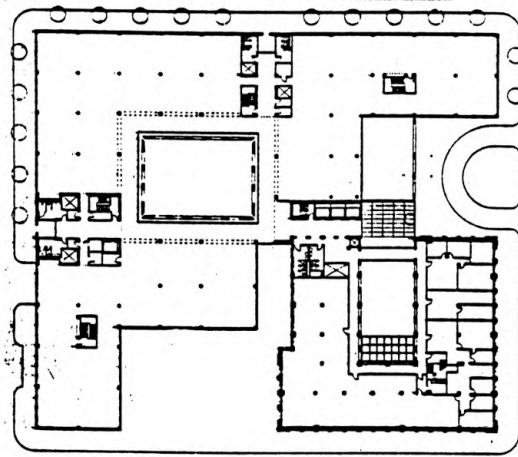
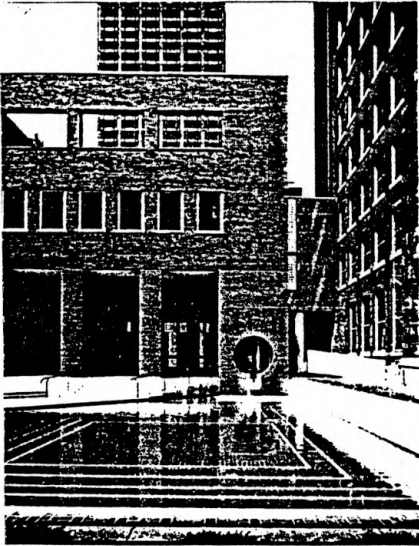

Figure 6-5.2 Wainwright State Office Complex, St. Louis, MO
(left) plaza & atrium; (right) plans & section

by courtyards and plazas. In retaining the original features of Sullivan's design, public entrances are provided in the new addition. An atrium is created to the north end, with bridges connecting each floor of the old building, allowing access to elevators relocated in a tower structure at the juncture of the old and new. The annex is comfortably rational, polite, and neutral. Its brick and red mortar match the old building's ruddy lower sandstone and the upper-level brick.

<2> Proper Solution

In searching for a proper design solution for the adaptive-use of the IOOF Hall, we have to examine the particular situation of the existing building and the program requirements for a cultural/recreational center. Which of the above three design solutions can be properly applied to this project? In fact, not all adaptive-use projects fall exactly into these three categories, as with some of the projects discussed in Chapter Five. But, these projects can always be seen as alternation of these three models. For example, the Grace Episcopal Church and Community Center project was obtained from an existing building shell. Most of its original structure was altered with new structure woven into it. It is characterized as a "shell model" with less amount of modification. In comparison, the Newark Community Center of Arts can be called a "shell model" with a greater amount of modification.

Let's first see whether a "shell model" is proper to this

project. The first problem with this solution is the space limitation of the existing IOOF Hall. Unlike the Whig Hall at Princeton University, the IOOF Hall is strongly limited in its overall volume, square footage and floor heights. Although the figures for the existing floor area (Whig Hall: 7,000 sq ft versus IOOF Hall: 6,585 sq ft) and the projected floor area (Whig Hall: 10,000 sq ft versus IOOF Hall: 10,210 to 11,210 sq ft) are very close to each other, it is not possible to generate additional floor area by adding an additional floor within the existing building. In other words, it is not possible to create another 4,000 sq ft within the existing shell as required by the program. Secondly, the IOOF Hall does not only have a sound shell but also a sound content. As discussed in Part One, the structure and other interior features of the IOOF Hall are still sound. Most walls, the floor system, ceiling and roof are in good shape and can be easily renovated or recycled. Chapter Four has revealed a spatial logic with all three floors for the proposed function. It would be irrational to tear them all down and start from scratch. Therefore, this design solution is inappropriate to the adaptive-use of the IOOF Hall in its strategy of extending only within.

Then, how about a "fragment model" ? As demonstrated in Meier's MOMA project, this design solution retains even less existing building elements than does a "shell model". Aesthetically, it may produce a dramatic effect that is impossible for any new construction, using original building fragments for the new function. Yet, it draws too little sympathy to the existing

building structure and spatial arrangement. Given the fact that the IOOF Hall is architecturally sound and worth saving as a complete structure, such a design approach is not suitable either.

Now, let's take a look at the "annex model". The possibility of north-side extension for the IOOF Hall has been announced in Chapter Four. Building an addition next to the existing building to accommodate the additional floor area is not only possible but viable. The three adaptive-use projects with this design solution mentioned in the last section, are successful examples of keeping the existing building structure intact and building additional structures to update the old.

To conclude, we select the "annex model" as the design solution for the adaptive-use of the IOOF Hall project. Although there are many technical and aesthetical lessons to be learned from the other

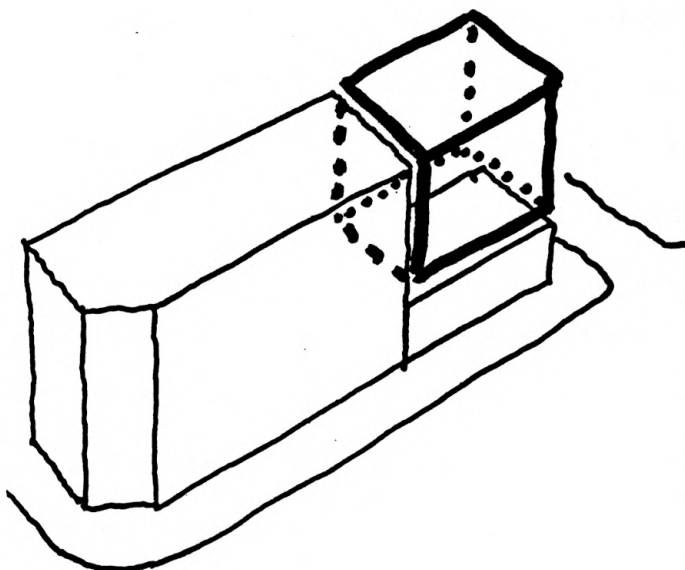

two solutions, the "annex model" is the best suitable solution in its general strategy for preserving the existing building, and extending to an available site to update the old building and accommodate the additional facilities. The annex is to be built to the north-side of the

existing IOOF Hall, where the Crystal Cleaners building sits (an undistinguished one-story structure), also owned by the IOOF

organization. The addition is to solve the problems of fire egress from the third floor and the problems with vertical and horizontal circulation inside the existing building, and to provide space for entrances, storage, administration and mechanical equipments.

<3> Other Design Strategies

Once a general design solution is chosen, architects need to set up further specified strategies in order to formulate design decisions. As shown in Chapter Five, different design techniques can be developed for a chosen design solution guided by different design strategies. The design strategy³³ for this project is summarized in the following two aspects: for the existing structure and for the new addition.

6.3-1 For the Existing Structure

The adaptive-use project for the IOOF Hall is seen as a combination of both restoration and modification in terms of the extent of change for the existing building. There will be only minor alterations in the building exterior and reinforcement of most of the good interior features that have been weakened or hidden. The original spatial arrangement will be maintained as long as it can fit the new use. However, in updating the building to code requirements, some extensive interior renovation work is

³³. It is also based upon the Interior's Standards for Rehabilitation (SISR) which were originally published in 1977 and revised in 1990, as part of the Department of the Interior regulations (36 CFR Part 67, Historic Interior Certifications). They pertain to historic buildings of all materials, construction types, sizes, and occupancy, and encompass the exterior and the interior of the historic buildings.

needed, such as relocation of walls and replacement of stairs.

Secondly, this project is to preserve as much as possible the historic character of the IOOF Hall, to avoid the removal of historic materials or alteration of features and spaces that characterize the building, and to preserve as much as possible the distinctive features, finishes, and construction techniques and examples of craftsmanship that characterize the IOOF Hall.

Thirdly, this project is to repair deteriorated historic features, replace those severely deteriorated features and make the new match the old in design, color, texture, and other visual qualities.

6.3-2 For the New Addition

Great efforts will be taken to keep the addition "anonymous"³⁴ by paying enough respect to the old building in terms of its height, proportion, the materials used, and facade composition.

Secondly, this project is to differentiate the new addition from the old and make it compatible with the massing, size, scale, and architectural features in order to protect the historic integrity of the IOOF Hall and the surrounding downtown neighborhood.

The third concern is called an "outside-and-inside" ideology. The design shall respond to the issue of architectural relationship between old and new from two points of view: from the outside of the building and from the inside of the building. The two respond

³⁴. Peter Blake, *The Architecture of Courtesy*, OLD AND NEW ARCHITECTURE: DESIGN RELATIONSHIP, pp. 90-114

to different criteria, utilizing different architectural vocabularies. The outside responds to the contextual streetscape and public values, maintains the historical visual characters of downtown Garnett and contributes to the integrity of a socially established sense of place. At the same time, the inside responds to functions and efficiency.

The above design strategies will guide the specific remodeling and new design from exterior to interior; from the first floor to the third floor; and from the overall spatial arrangement to the fine structural detail.

Chapter 7

DESIGN DECISIONS

This chapter presents a set of design drawings that describe design decisions. Explanatory notes accompanying each of these drawings account for some key issues, such as demolition plans, the new addition design, preservation methods, a barrier-free environment and material recycling.

<1> Thinking from Top to Bottom: Demolition

The first issue that the author faces is how to alter the existing floor plans of the three stories in order to locate the proposed facilities into the building. It asks the question, what to tear down and what to keep? Chapter Four has suggested a list of proposed facilities for each floor. This was written in consideration of both the existing building and the new addition. In order to make reasonable decisions for demolition, we need to draw an overall picture of both the existing building and the new addition. Since the circulation and fire egress problems are so overwhelming with the third floor, it is wise to start our thinking from this floor.

7.1-1 Third Floor

The overall existing gross floor area of this space is 2,195 sq ft. The former IOOF grand meeting hall is 1,550 sq ft. The design program suggests developing this meeting hall as a community assembly room for the proposed cultural/recreational center. The

projected floor area is 1,700 sq ft to 1,850 sq ft. There is only one stairway leading up from the second floor. To meet the Code requirements, there should be at least one more stairway. These two stairways should be at opposite locations, preferably at the north and south ends, due to the elongated rectangle shape of the

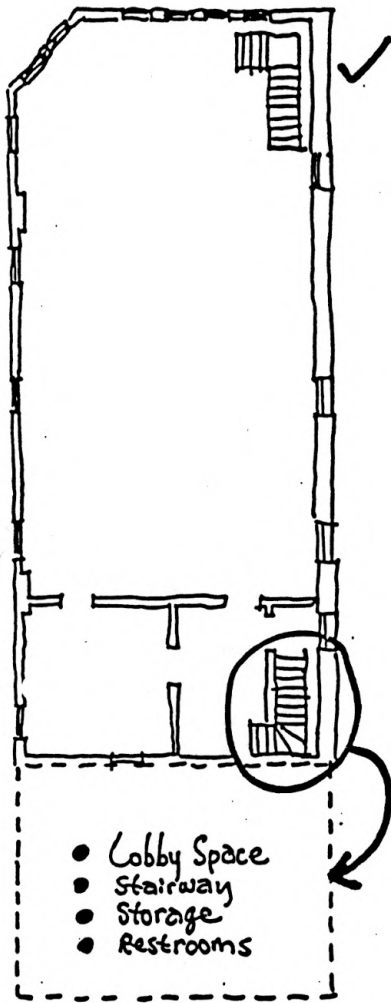

Fig. 7-1

meeting hall. This will allow people use of both stairways if a fire occurs. The problem is that the existing stairway is to the north, and so is the new addition. While the new addition may easily provide a new stairway, it can not solve the fire egress problem. The travel distance would still be too far from either of them. Is a southstairway possible? The answer is "yes". Since there is already a southstairway leading from the first floor to the second floor, why not extend it to the third? As shown in figure 7-1, a new south-stairway has to be fit inside the former IOOF grand meeting hall, solving the circulation and the fire egress problems with the north stairway in the new addition. The sketch also

indicates that we can enlarge the former IOOF meeting hall by tearing down the existing stairway and the walls that enclose the former kitchen and waiting room. We can thus get a community

assembly room (floor area: 1,880 sq ft, not counting the southstairway and storage and control rooms).

The demolition plan for the third floor is shown in figure 7-2 on the next page. The demolition (darkened walls and dotted areas) includes the northstairway, the walls around the former kitchen and waiting room. These materials, including the four doors, are to be recycled.

7.1-2 Second Floor

Going down to the second floor, we get another 2,195 sq ft existing floor area which is to be used for the arts and crafts exhibition and show space. The third

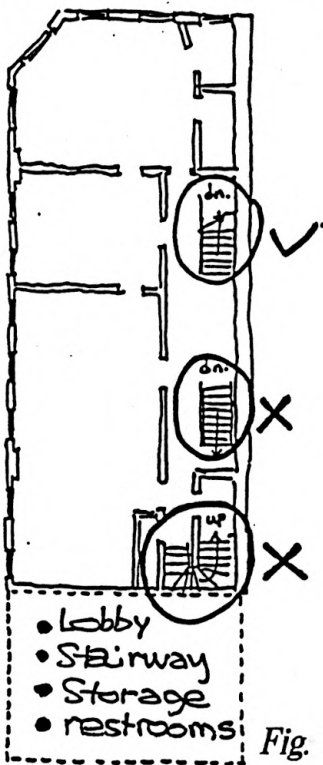

floor demolition plan determines that the northstairway which goes up to the second floor is to be removed. As demonstrated in the preliminary sketches, this floor can be retained mostly in its original spatial arrangement since it serves very well for the proposed function. Because the new addition provides a new northstairway leading up from the first floor, the existing northstairway going down the first floor can also be removed.

Therefore, we get an extra 120 sq ft of floor area that can be used to widen the corridor, where arts and crafts objects can be exhibited.

The demolition plan for the second floor is shown in figure 7-4.

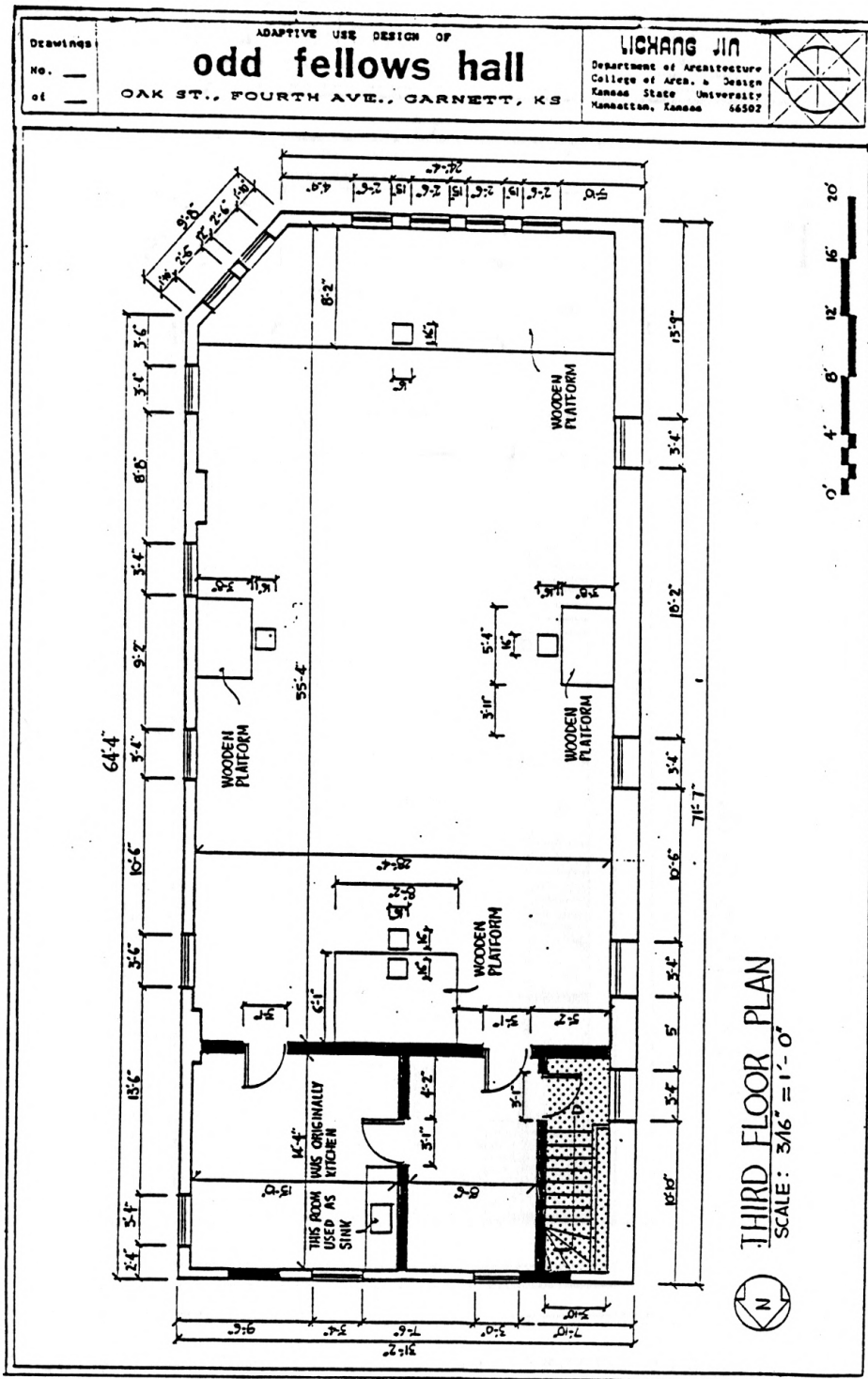

Figure 7-3 Demolition Plan: Third Floor
(Demolition: darkened and shaded area)

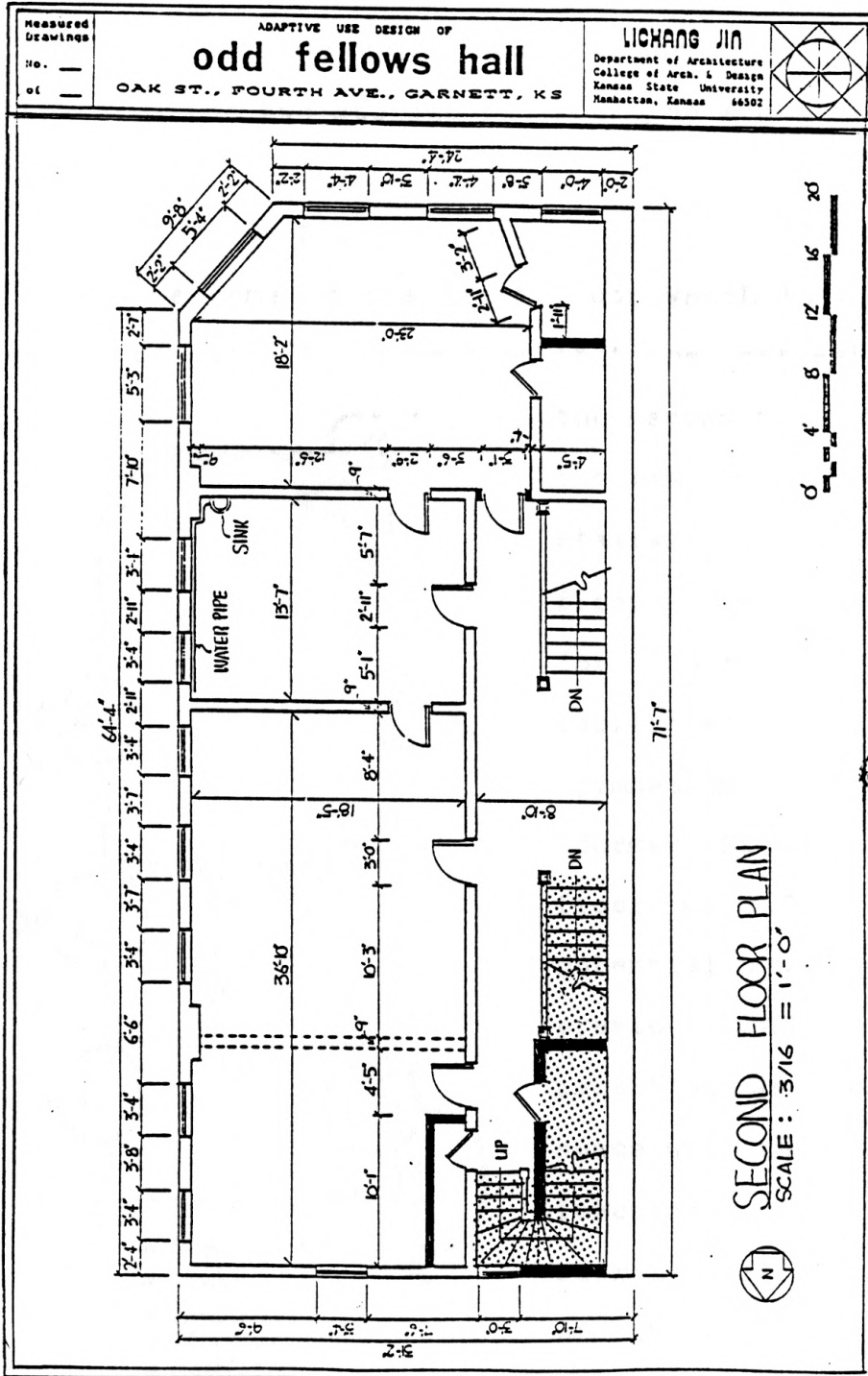
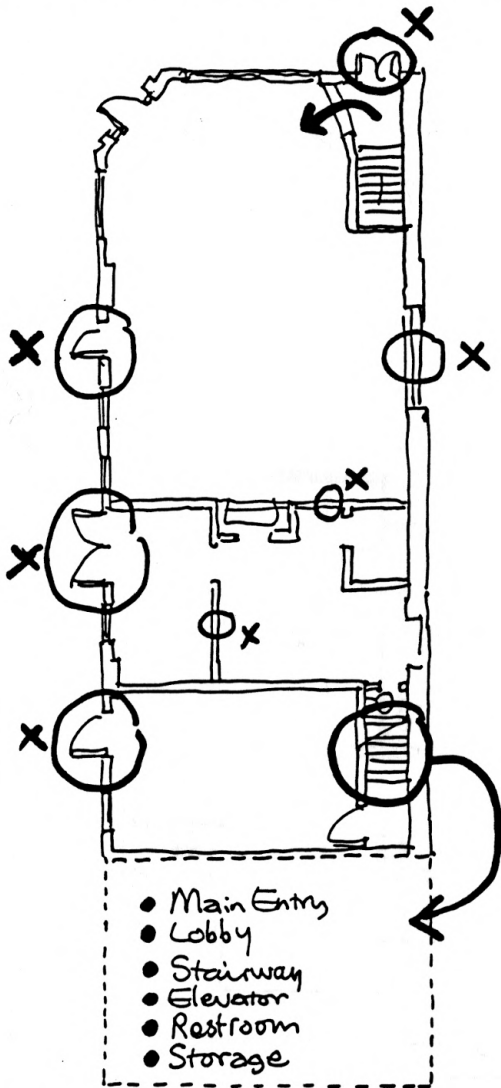

Figure 7-4. Demolition Plan: Second Floor
 (Demolition: darkened and shaded area)

The demolition includes the northstairway leading up to the third floor and the one going down to the first floor, and the wall separates the two storage rooms at the south end.

7.1-3 First Floor

Now we come to the first floor which is also 2,193 sq ft in existing space. It is certain that the north-stairway going up to



the second floor is to be removed since the new addition can provide a new stairway. The program suggests this floor to be used as game rooms and for other physical fitness facilities, in other words, a micro "gymnasium". The largest room (former Fitness Shoppe) on this floor is 1,050 sq ft. It has a potential stage, as identified in previous chapters, once the wooden partitions are removed. The enlarged space will then be a perfect multi-functional room for the proposed recreational facilities. The removal of these wooden partitions also ensures the spatial connection with the new addition, which may provide

Fig. 7-5

men and women restrooms, and offices. Another connection needs to

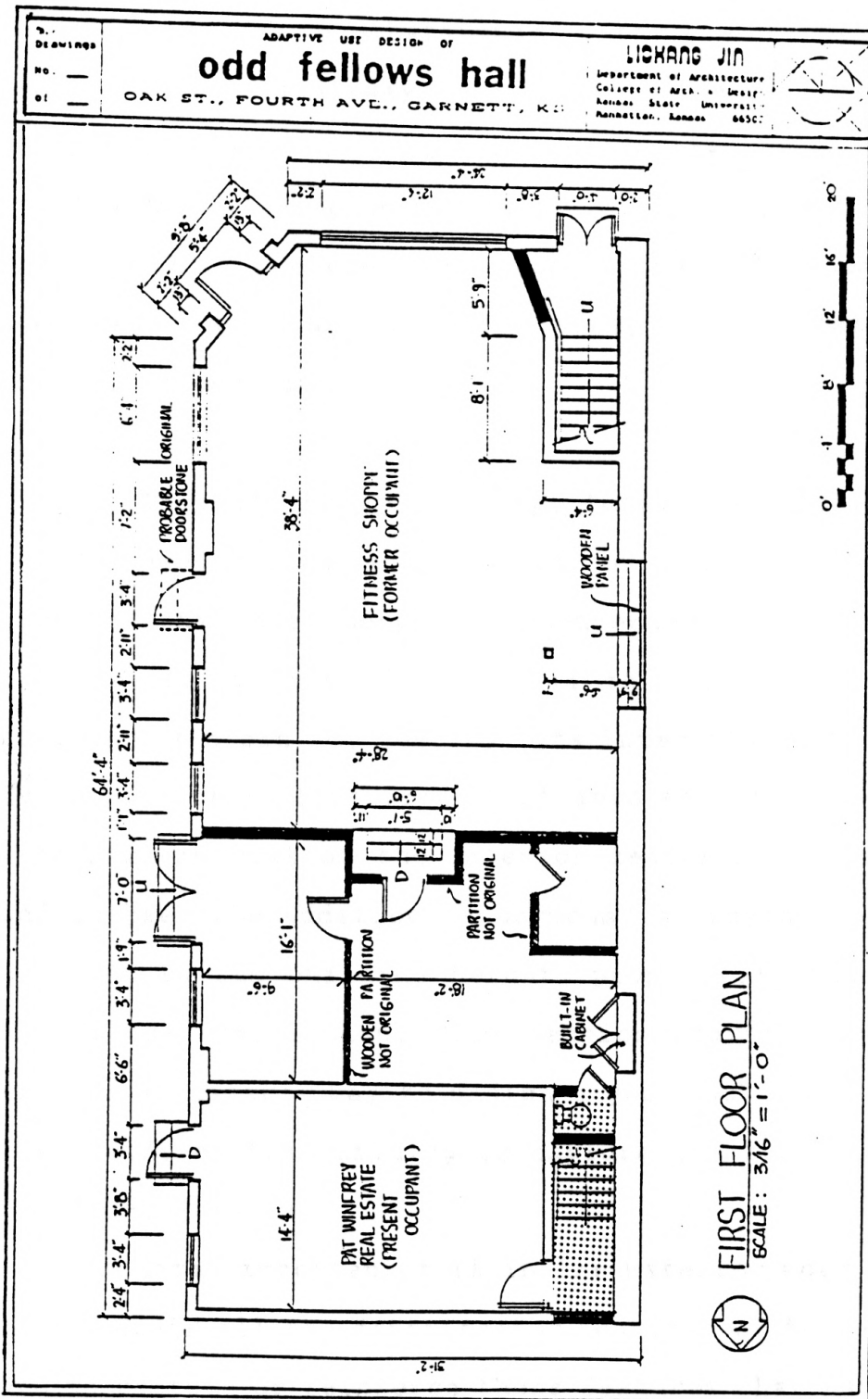

Figure 7-6. Demolition Plan: First Floor
 (Demolition: darkened and shaded area)

be made is the southstairway with the former fitness room. Presently, this stairway leads only to the outside, and nobody can go up to the second floor from inside the building.

The demolition plan for the first floor is shown in figure 7-6. The demolition includes the northstairway, the wooden partitions on the stage, and the wall separating the southstairway from the former fitness room.

<2> Thinking from Outside to Inside: New Addition

Building a new addition to an existing building raises a question that most people are concerned about. Will the addition fit the old building ? Or, will this new addition help the old building maintain, or destroy, its integrity ? As reflected in the design strategy, this project strives to preserve all the existing exterior and most of the interior features of the old IOOF Hall, and to keep the addition "anonymous" by paying respect to the old building in its building height, proportion, the materials used, and facade composition. This section starts from the outside to examine a suitable way to design a good addition, and then goes to the inside of the building to explore its functional efficiency.

7.2-1 Facades

The first important task in the exterior work for this project is to repair all the deteriorated features of the existing building and to restore or reinforce those features that have been hidden or removed. As shown in the old photographs in Chapter One (on page 16 and page 17), the original facade of the IOOF Hall was neat and

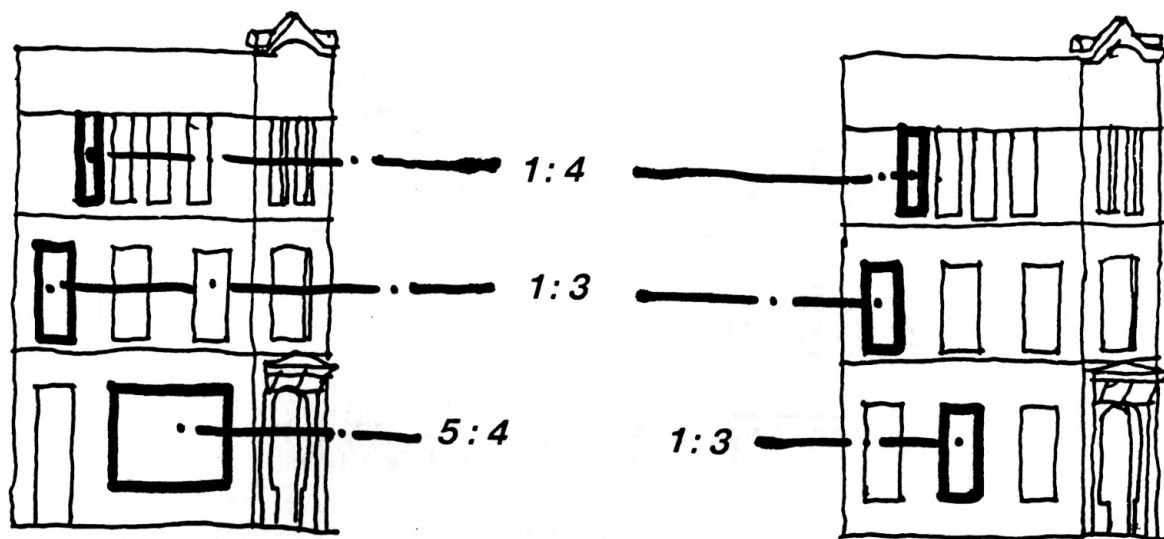

Fig. 7-7 South Facade (left: existing; right: proposed)

uniform. The proportions of the windows were of 1:4 (that of the third floor on the south facade) and 1:3 (the rest on the south facade), all were vertical, and had a slight late Gothic style. Yet, now, the south facade had been altered by widening the first floor window into a proportion of 5:4, a horizontal element, quite alien to the overall composition (see figure 7-7). The suggested south facade shown in figure 7-9 on the next page shows the restoration of the original three window compositions for the first floor with 1:3 proportion. The south entry is removed as already discussed in the last section.

On the east facade, we come to the issue of the new addition. We know that the proposed new addition will run up to three stories. But what does this addition look like? And we know that there will be a building entry, which is in fact the main entry, at the addition part of this facade. How does entry emphasize itself? The above window composition analysis has decided the size and the

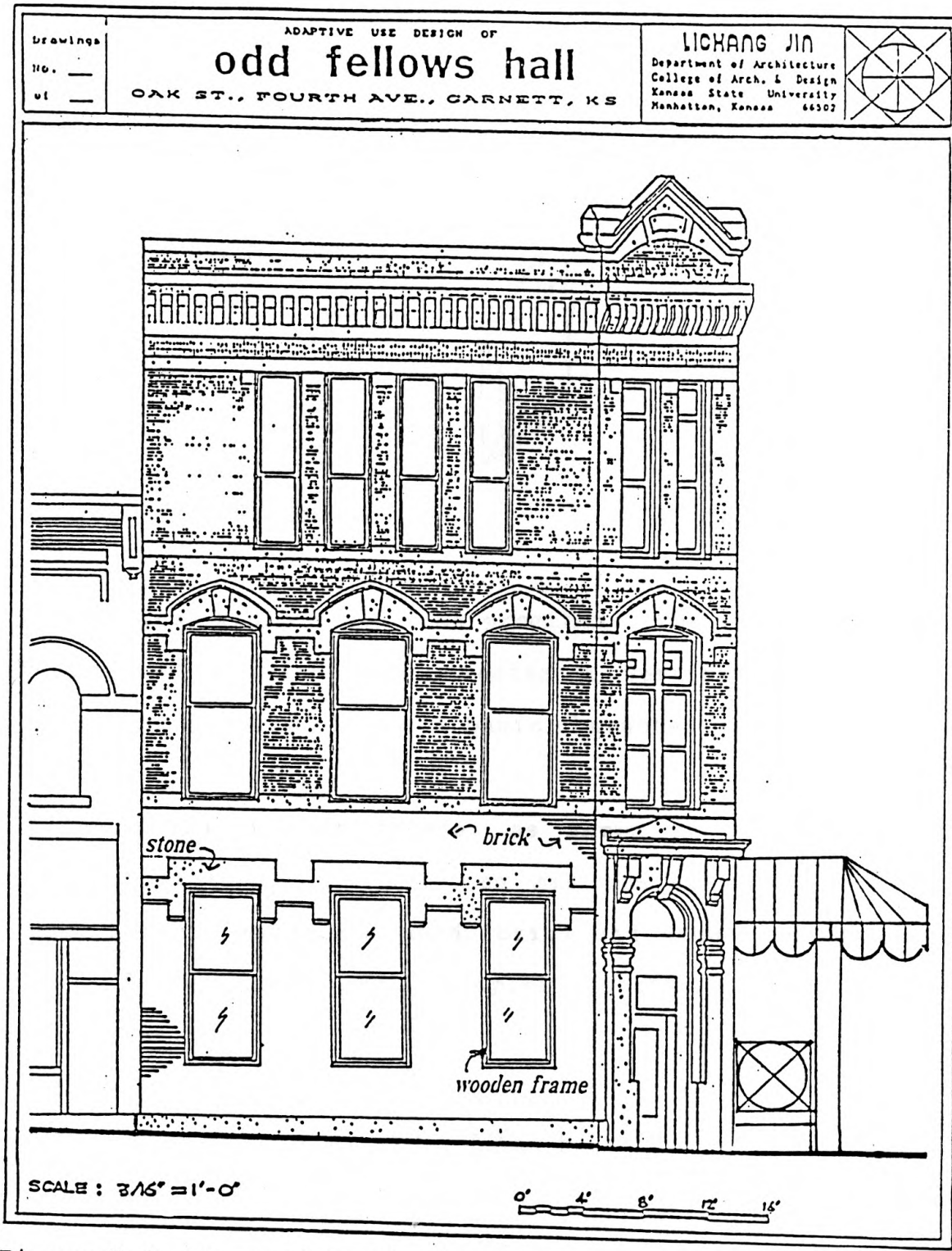

Figure 7-9. Proposed South Elevation

proportion of the windows for the addition. And the diagram (figure 7-8) indicates that we divide the addition into three parts, set back the two at either end, and align the middle part with the

existing building.

The set back of the south part of the addition provides room for the main entry, and serves to make the overall

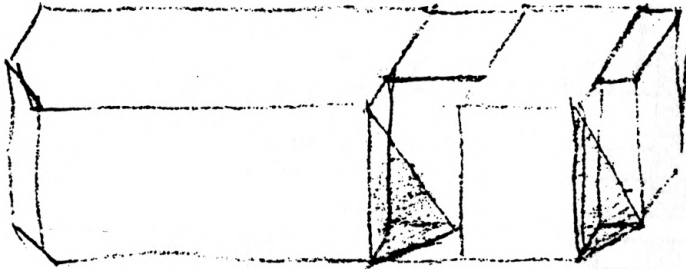

Fig. 7-8 East Facade Massing

addition less visible and less prominent. The three-part division of the new addition also creates a vertical feeling in its proportion, which has been the basic characteristic of the existing building.

The proposed east facade, as shown in figure 7-10, also indicates that the new addition has the same building height, window height, materials used (brick and stone wall, and wooden window frame), yet with simpler details and more refined decorations.

7.2-2 New Floor Plans

Now, we need to go inside of the building and start drawing the floor plans for the new addition and the overall building. Let us first look at the first floor. As shown in the diagram (figure 7-8), the set back entry lobby serves as a focal space for the functions of reception, vertical and horizontal circulation, and

Drawings
No.
of

ADAPTIVE USE DESIGN OF

odd fellows hall

OAK ST., FOURTH AVE., CARNETT, KS

LICHANG JIN

Department of Architecture
College of Arch. & Design
Kansas State University
Manhattan, Kansas 66502

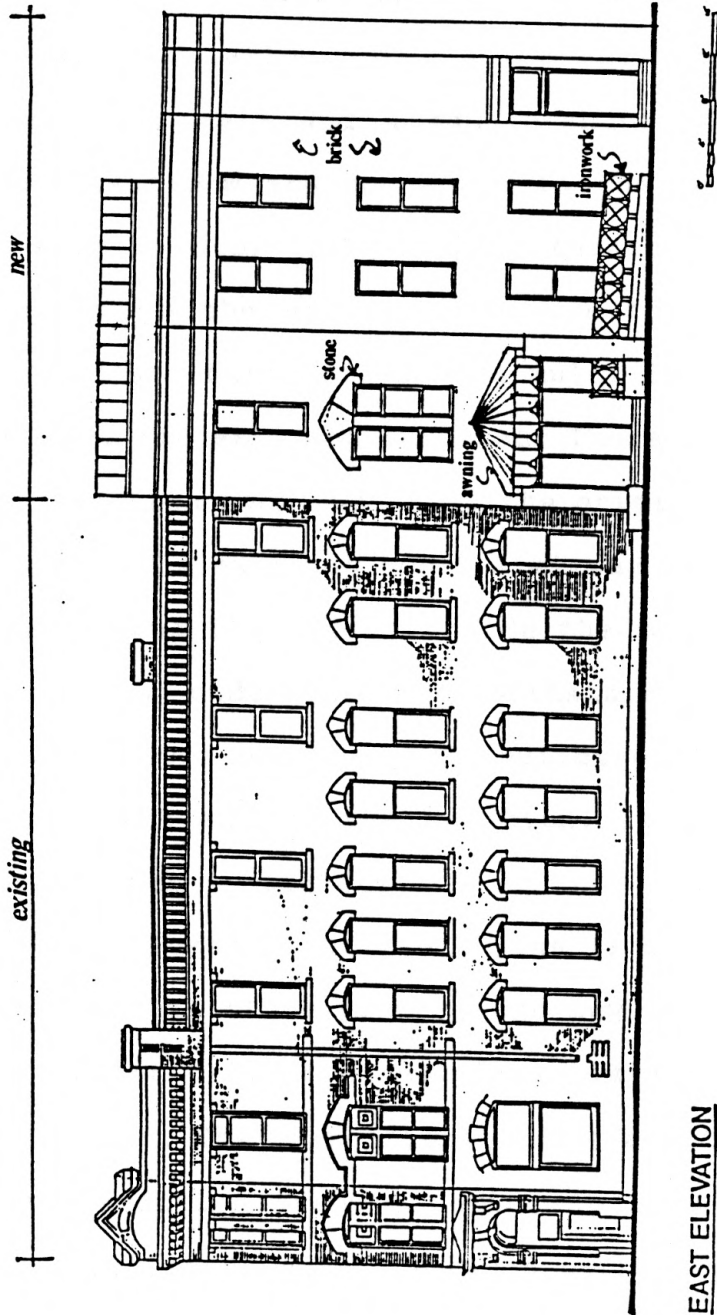
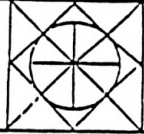

EAST ELEVATION
SCALE 3/16" = 1'-0"

Figure 7-10. Proposed East Elevation

transition between the old building and the new addition. As a major visual element, the awning above the main entry is built to draw people into the building. Adjoined with the entry lobby is the vertical circulation core, which includes one double-L stairway, one elevator well and a square-shape lightwell. Both men's and women's restroom are connected to the entry lobby by a corridor. When people enter the building through the main entry, they may either go up the stairway (or use the elevator if it is to be installed) or turn left at the multi-function room, the game room located in the existing building. There is also a south entry to the multi-function room, which is the original building's entry in the IOOF Hall. The existing south stairway is renovated, which leads up to the second floor from inside the multi-function room. A snack bar is set up underneath the south stairway which may serve not only the first floor but the whole building. A service entry is created at the north end of the addition. It is connected to the entry lobby through a corridor.

The proposed first floor plan is shown in figure 7-11.

The second floor plan of the new addition is almost identical with the first floor except there is a storage room at the end of the corridor. The transitional lobby adjoins the existing space and the new addition. People coming up from the entry lobby via the north circulation core are faced with a corridor that leads to the exhibition space in the existing part of the building. There is a small framed archway beside this corridor, taking the place of the previous north stairway. It serves also as an exhibition space where

Drawings

No. _____

of _____

ADAPTIVE USE DESIGN OF

odd fellows hall

OAK ST., FOURTH AVE., CARNETT, MO

LICHANG JIN

Department of Architecture
College of Arch. & Design
Kansas State University
Manhattan, Kansas 66502

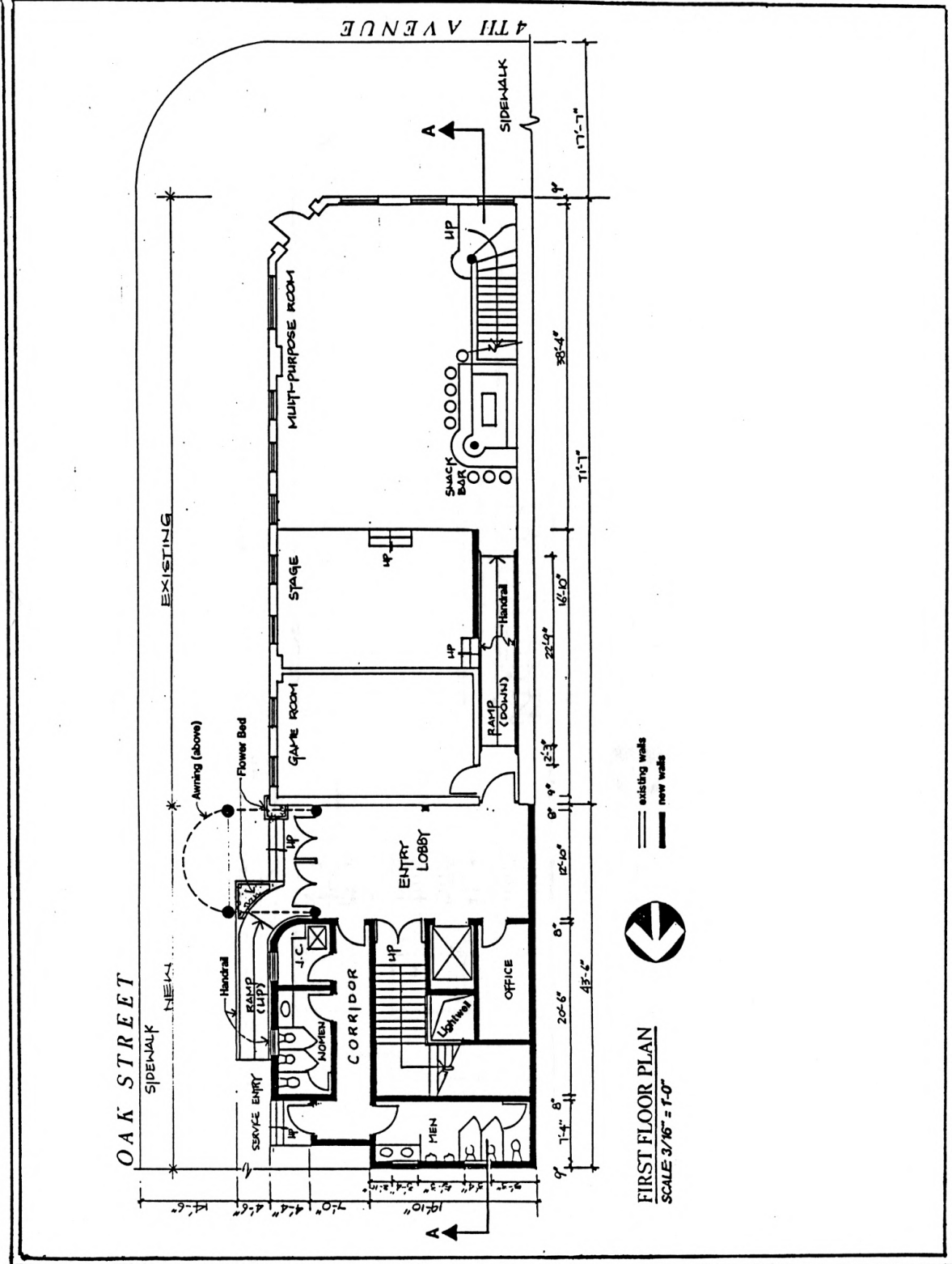
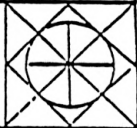
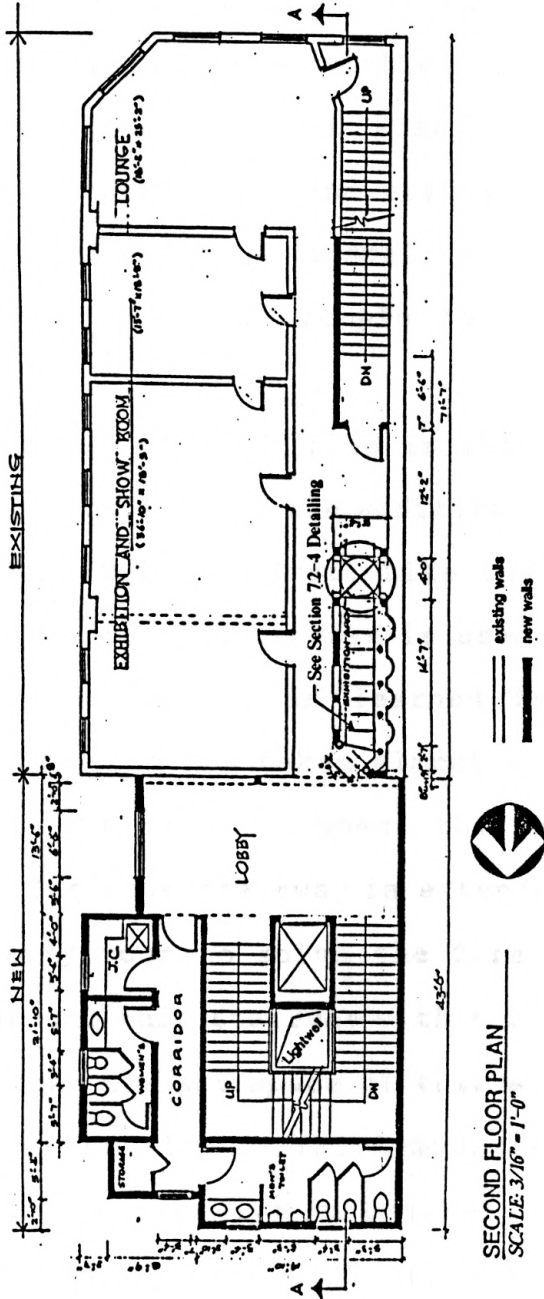

Figure 7-11. Proposed First Floor Plan



SECOND FLOOR PLAN
SCALE: 3/16" = 1'-0"

Figure 7-12. Proposed Second Floor Plan

arts and crafts objects can be placed in little alcoves carved from the existing west wall. Walls are built around the southstairway with doors installed as required by the Code in case of fire. A lounge area is designed at the south end of the building for people to rest and socialize. This is also a place where people may discuss the price of the arts and crafts objects with the artists or merchants, in other words, a small market place. Spatially, it is a transitional place for people to go down or up the south stairway.

The proposed second floor plan is shown in figure 7-12.

Again, the third floor of the addition is almost identical with that of the second and the first. Like the first floor, the spare space of the circulation core is used as an office, which has a floor area of 83 sq ft. As learned from section 7.1-1, the community assembly room now takes almost all the existing space of the third floor. Two doors connect the addition lobby with the community room. The southstairway is extended from the second floor into the community room to solve the fire egress problem. A wall area is built around this stairway with a fireproof door installed. A waiting room take the air space of this stairway, which serves as the south end of the stage. Semi-temporary seats are arranged in twelve rows with two pathways in between. The seating capacity is 92 people, among which two handicap seats are arranged in the middle row. A small control room is built against the existing north wall for film showing and sound effects.

The proposed third floor plan is shown in figure 7-13.

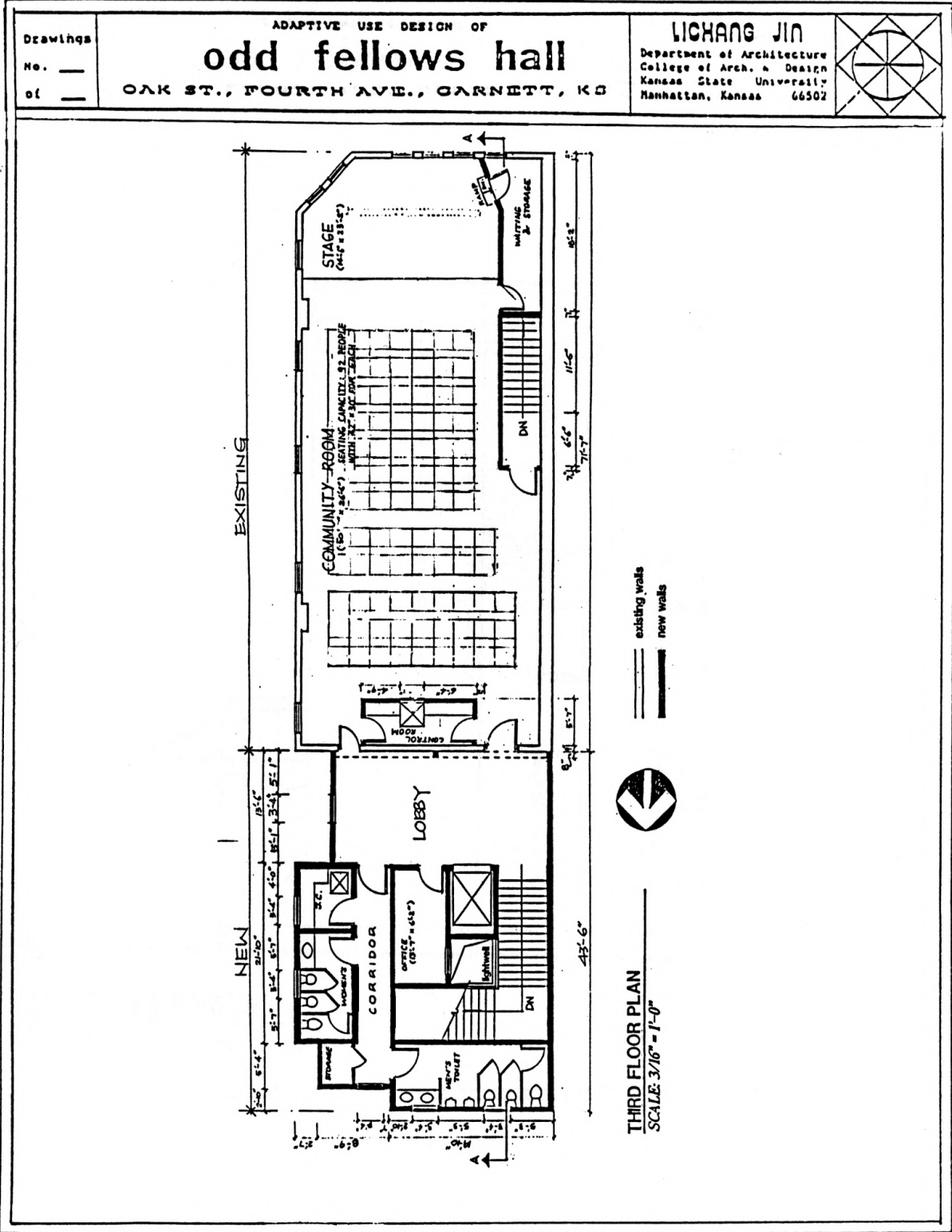

Figure 7-13. Proposed Third Floor Plan

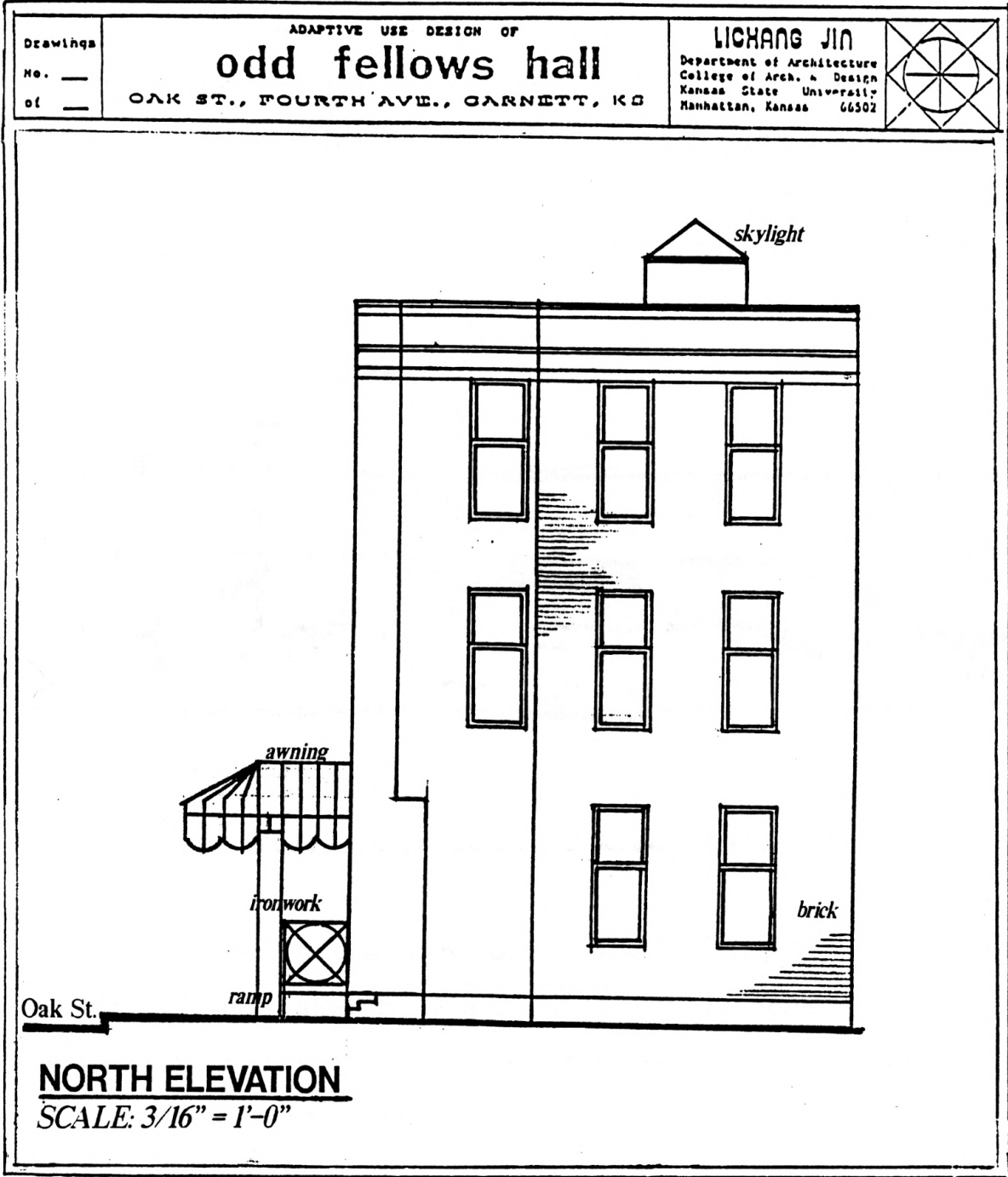

Fig. 7-14 Proposed North Elevation

7.2-3 Sections

In addition to the floor plans, section drawings reveal more of the spatial structure in another dimension. The preliminary sketch (figure 7-15) shows some of the thinking in vertical circulation, floor level change, space usage underneath the

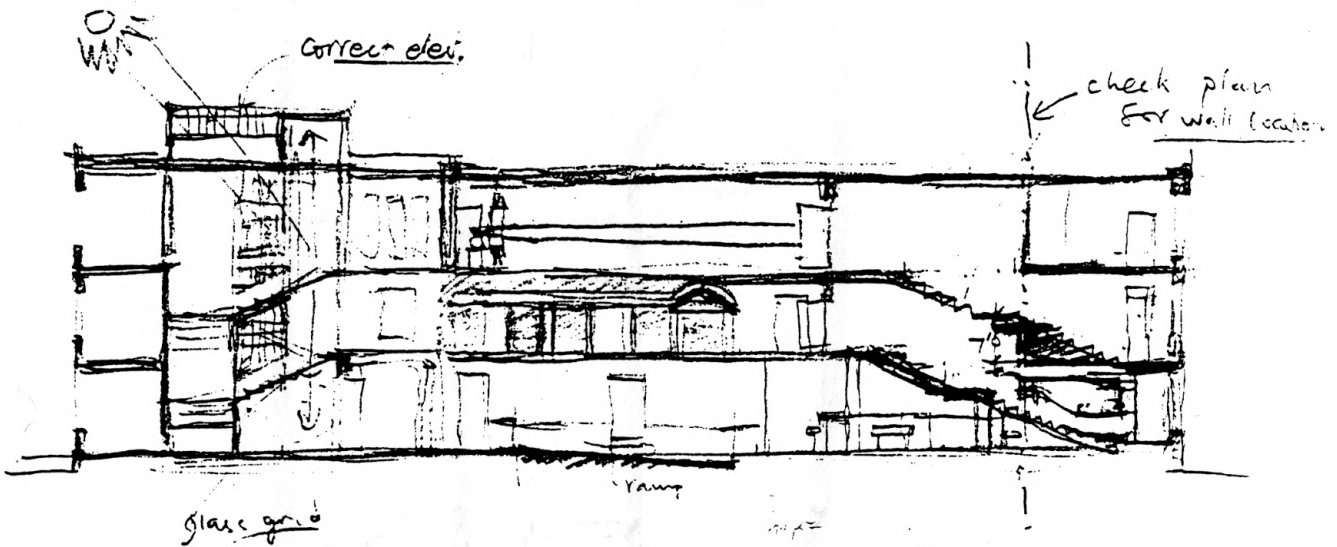

Figure 7-15. Preliminary Design Sketch: North-South Section

stairways, and lighting control for the circulation core. The final version of this sketch (figure 7-16) shows some of the interior features in both the existing and the new addition of the building.

The axonometric section drawing (figure 7-17) shows another view of the new addition. All three stories are seen in this drawing with its own spatial logic and how it is connected with the existing building.

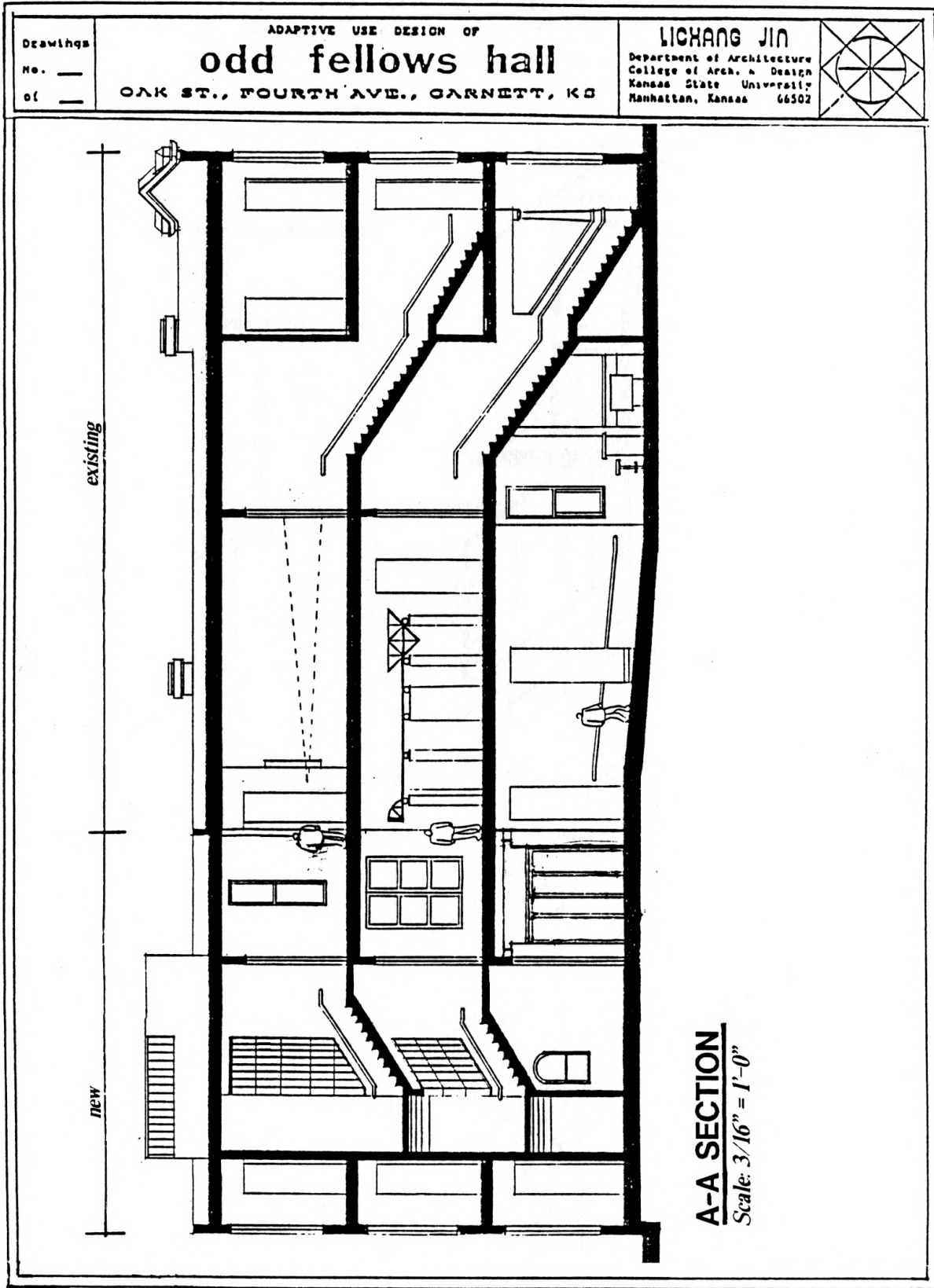

Figure 7-16. Proposed North-South Section

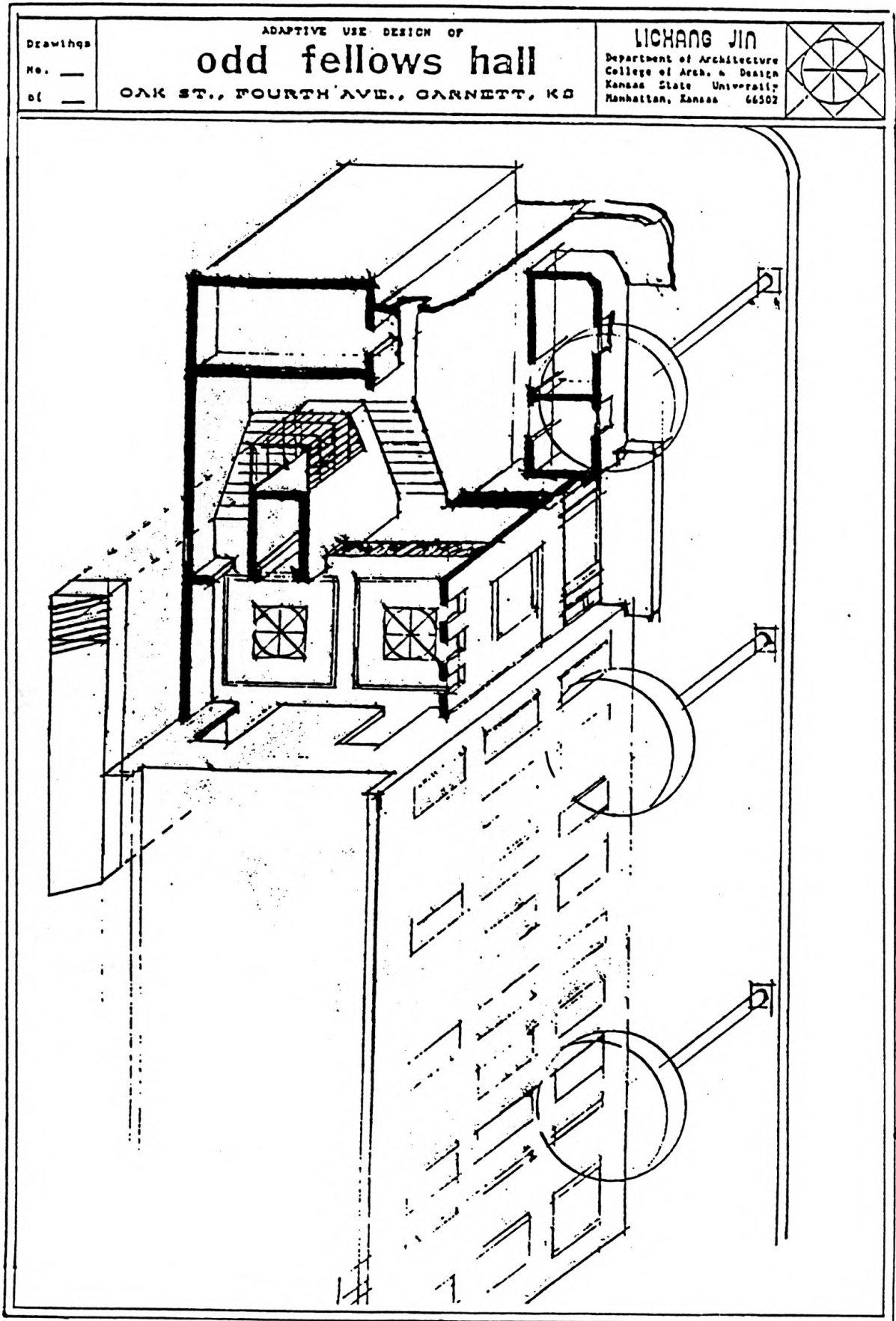
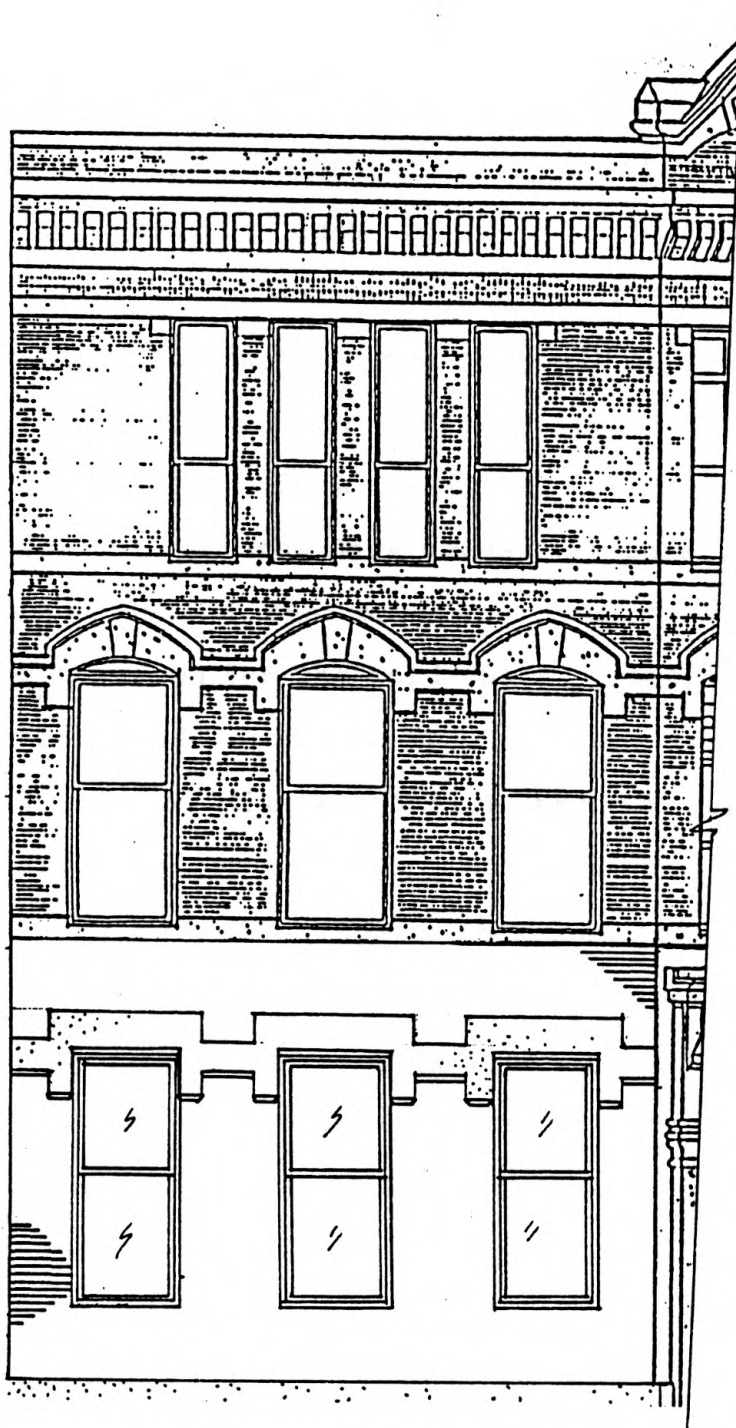

Figure 7-17. Axonometric Section

7.2-4 Detailing



The architectural detailing refers to the general design strategy and anchors the overall design concept of this project, ie., old versus new and exterior versus interior. For most of the exterior features of the existing building, it is to retain the original design. Figure 7-18 shows the restoration of three first floor windows on the south facade. This is based upon the old photographs of the IOOF Hall in 1900s (photo 1-6 and 1-7). These windows are almost identical with the windows on the second floor except the stone lintels are horizontal instead of arch-shape.

Figure 7-18. South Facade Windows

For the interior of the existing building, different detailing methods are applied to those elements that were original from those that are not. Figure 7-19 shows the detailing of the first floor entry of the southstairway. This space is not original to the existing building. It is designed to bring people up or down the southstairway from inside the building. Its design has to be visually attractive to draw people's attention. It also has to be simple in its form and tranquil in its character to be compatible with all the other existing features inside this room. The author decided to use a classical round column as the major visual element, and the dark wooden rim parallels with the wooden handrail to indicate the movement, and to intentionally ensures a 1:4 proportion for the void space, a proportion that is heavily used in the facade composition of the old building. Figure 7-20 shows the design of the exhibition arch at the northwest corner of the existing second floor. When the two original north stairways are taken off, this space is connected with the lobby space of the addition. The exhibition arch is designed to divide this space into two pieces, one as a corridor and one as an exhibition space. This exhibition arch serves as both a "prelude" and an "epilogue" of the main exhibition rooms. Small alcoves are created by cutting off some of the thick existing wall (22 inches in width). People may walk into this arch looking at the arts and crafts works that hung on the wall and placed in the alcoves. The detailing of this exhibition arch is to be simple and refined.

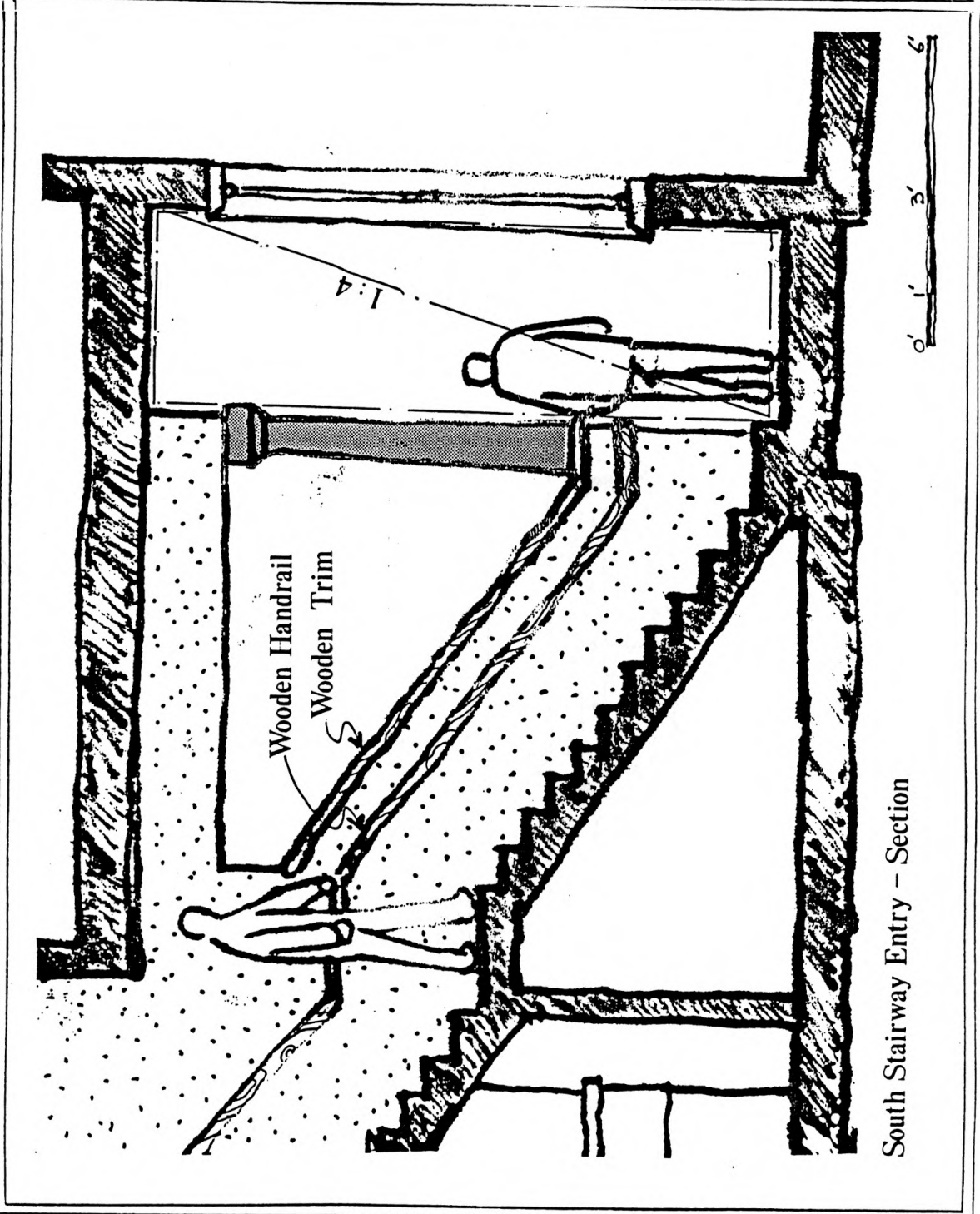

Figure 7-19. Detailing of Southstairway Entry

Drawings
No.
of

ADAPTIVE USE DESIGN OF
odd fellows hall

OAK ST., FOURTH AVE., GARNETT, KS

LICHANG JIN

Department of Architecture
College of Arch. & Design
Kansas State University
Manhattan, Kansas 66502

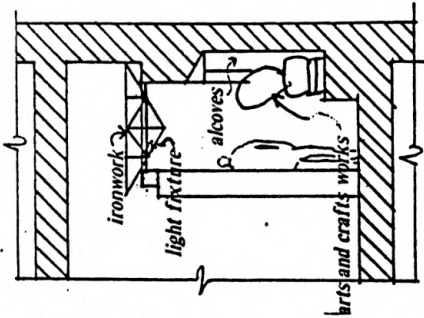
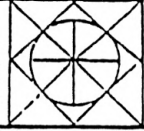

A-A SECTION

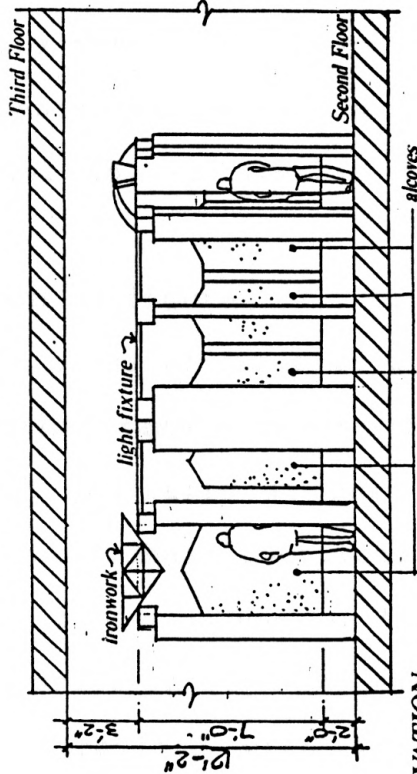

ELEVATION

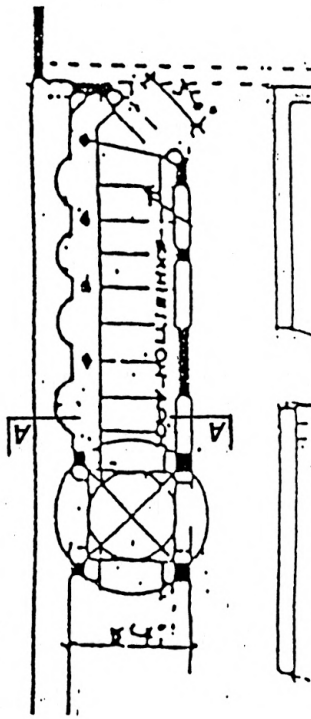

PLAN

EXHIBITION ARCH ON 2ND FLOOR

Fig. 7-20 Detailing of Exhibition Arch on the Second floor

<3> Other Key Issues

7.3-1 Barrier-Free Environment

Making this cultural/recreational center a healthy, pleasant and efficient environment for people of all ages, including those who are physiologically less competent, has been one of the concerns of this project. The Title III of Americans with Disabilities Act (ADA)³⁵ has included detailed design recommendations for new construction as well as alterations to existing buildings. This sweeping legislation is designed to extend civil rights protection to persons with disabilities. It requires building designers to provide disabled persons accommodations and access equal to, or similar to, that available to the general public.

As shown in figure 7-21, this project has provided wheelchair-users, as a class of disabled persons, a ramp going up to the main entry. Another ramp has been designed for the first floor level change with handrails at both sides. In the community assembly room, four wheelchair locations are provided in the middle row. An accessible route connects these seating locations with the performing stage through the waiting room. On each floor, restroom spaces are provided with accessible doors and turning space. Lightweight and slow-closing doors are installed at all entries marked with wheelchair signs (see figure 7-21).

³⁵. This act was signed by President Bush in July 1990. The Department of Justice's final rules implementing Title III of the act was printed in the FEDERAL REGISTER, 28 CFR Part 36, July 26, 1991.

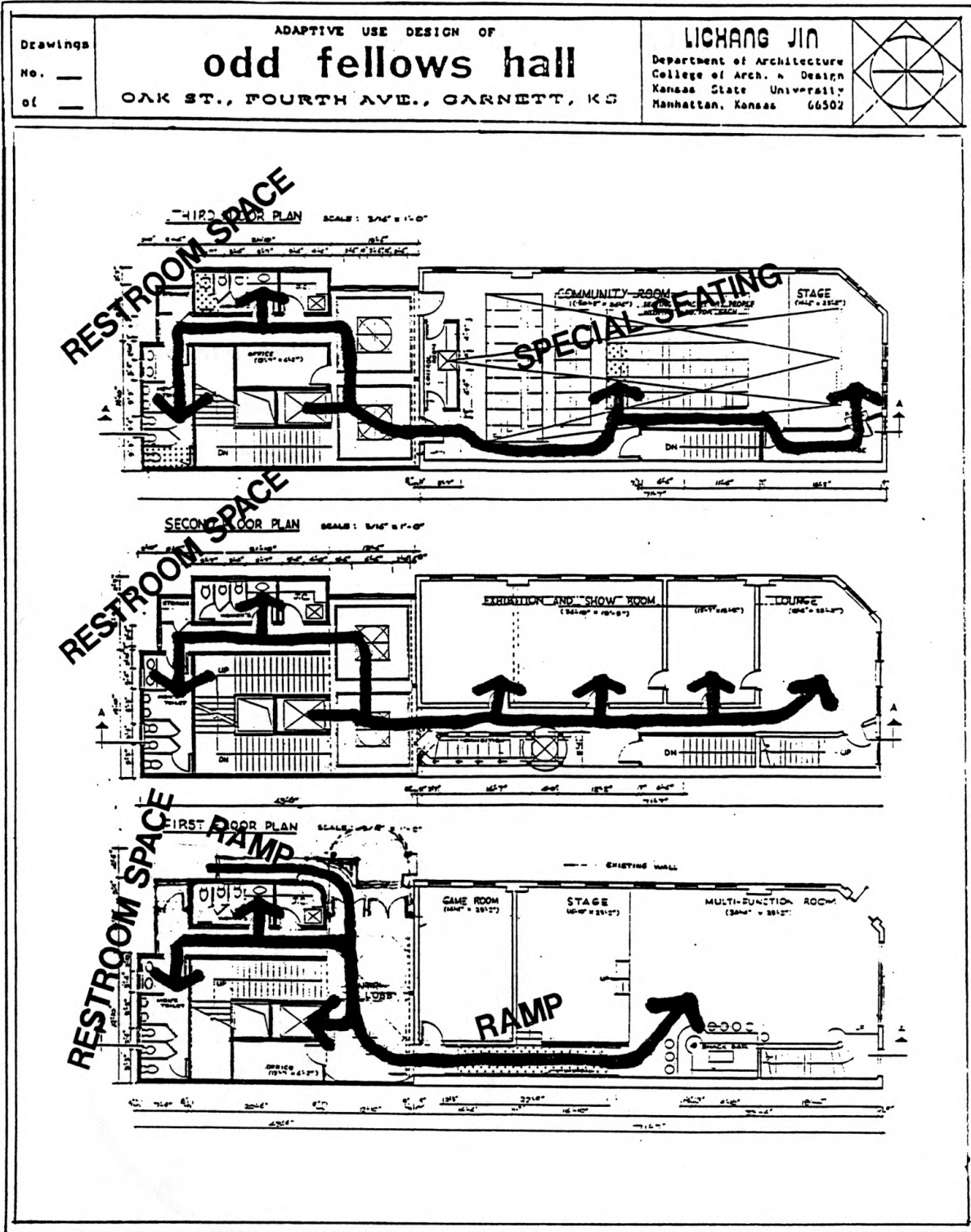

Figure 7-21. Barrier-Free Environment

7.3-2 Recycled materials

As one part of the adaptive-use program, all torn-down materials in good condition are subject to reuse. These include the masonry, wood, metal, glass, and other salvageables culled from the existing building during its partial demolition. The concern in selection of materials for construction of the new addition is with making them close or compatible to those used in the existing building in type, color and texture.

7.3-3 Parking and Other Site Factors

In a small town like Garnett, parking is as demanding as it is in bigger towns for downtown buildings. Presently, most of the buildings downtown have their parking accommodation along the street. As shown in map <2> (page 4) and in figure 2-1 (existing site plan, page 34), the city library, post office, city hall, senior center, and even the courthouse do not have a special lot for parking. Around the Square, there are more than 500 parking

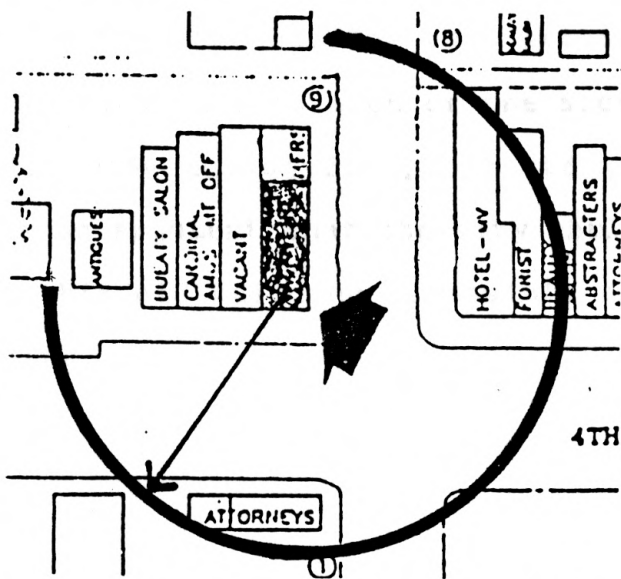

spaces available along Oak Street, Fourth Avenue and Fifth Avenue. All these parking spaces are within five minutes walking distance from one another. As figure 7-22 indicates, there are about 100 spaces

Figure 7-22. Parking Consideration

available along the street in the area of a 200 foot radius from the new cultural/recreational center. This amount of parking space is enough for the community assembly room use and other events happening in this building.

The site plan for this project is shown in figure 7-23 on the next page. The curb ramp is made for wheelchair-users to get on and off the sidewalk, and four parallel parking spaces along Oak Street, which are closest to the main entry, are preserved for them, too. Like in many small towns in Kansas, sidewalks in downtown area are wide in Garnett. The sidewalk around the IOOF Hall is 17'-7" in width along 4th Avenue and 14'-6" in width along Oak Street. Taking the advantage of this wide sidewalk, a ramp (4'-6" in width in itself, 5'-8" in width including the column, and 20'-0" in length) is designed for wheelchair-users to go up to the main entry in the addition. This has used 90 sq ft of the sidewalk area along Oak Street. The ramp protrudes 5'-8" from the property line, leaving this portion of the sidewalk 8'-10" in width, which is still wide enough for people to use. This design decision is made as an argument that the city shall give special clearance for making this old building accessible to the disabled people in the community.

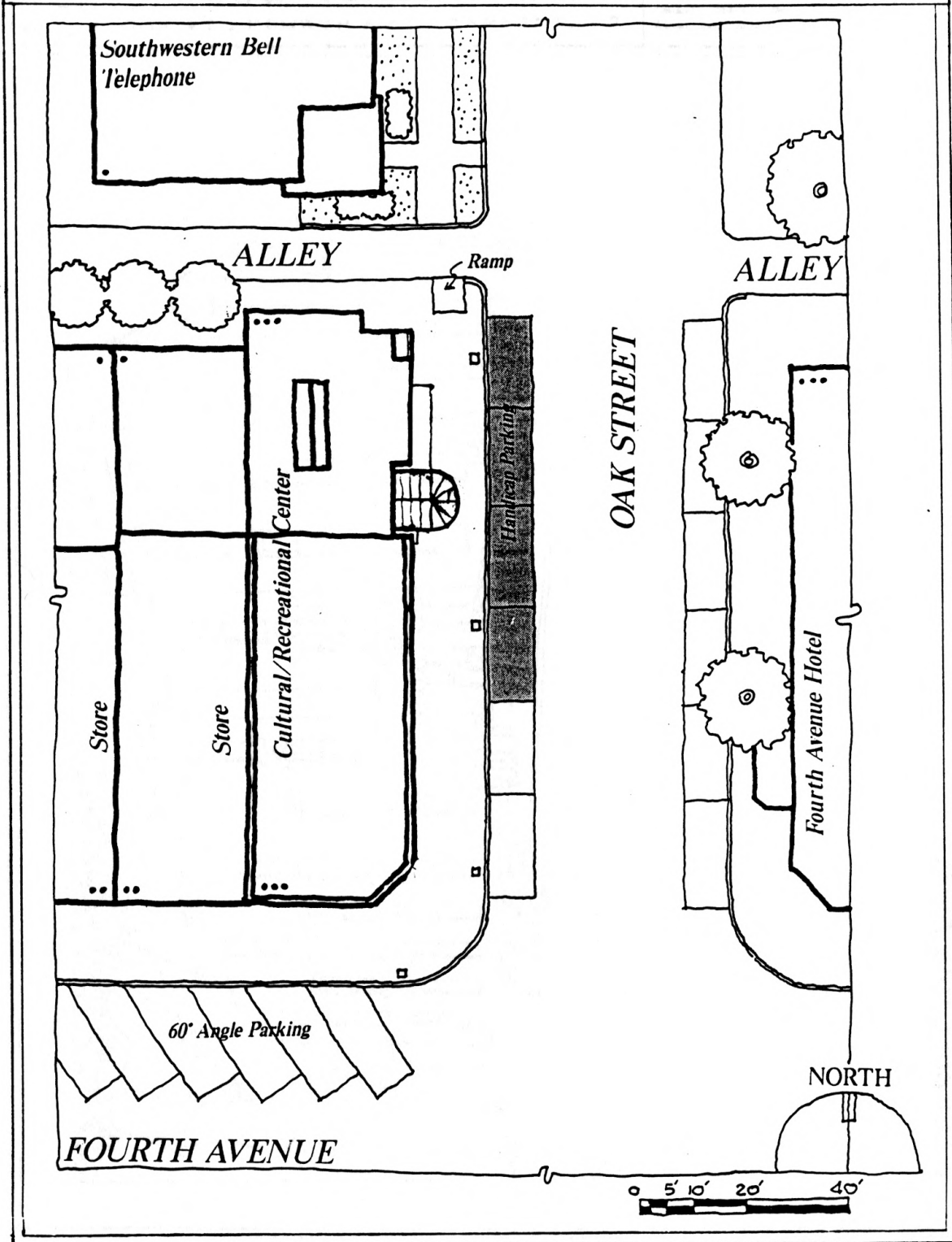

Figure 7-23. Proposed Site Plan

Drawings

No. —

of —

ADAPTIVE USE DESIGN OF

odd fellows hall

OAK ST., FOURTH AVE., GARNETT, KS

LICHANG JIN

Department of Architecture
College of Arch. & Design
Kansas State University
Manhattan, Kansas 66502

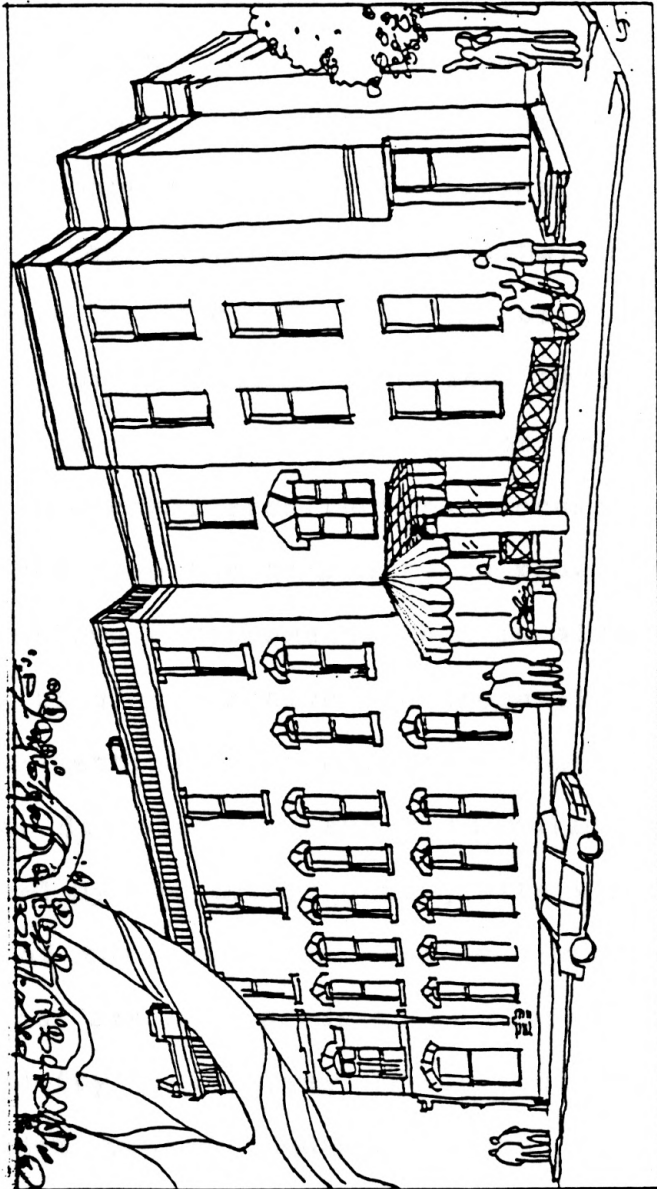

A PERSPECTIVE VIEW

Figure 7-24. A Perspective View Looking From 4th Avenue Hotel

Chapter 8

CONCLUSIONS

This thesis proposes an adaptive-use for the IOOF Hall in Garnett, Kansas, as a cultural/recreational center for the community. The following primary aspects of concerns, which have been addressed in the previous seven chapters, need to be emphasized again in this final chapter:

<1> Conducting an architectural survey

As a late 19th Century building, the IOOF Hall has no documents available to account for the original design, past occupancy history, and existing condition. This thesis is started with the efforts of setting up a file for the building, with maps, floor plans, and other architectural documents and technological notes, which may help the community to know about the building, and thus the downtown environment. This is also essentially the first step for writing an adaptive-use proposal.

<2> Getting the community's input to the proposal

The decision to save this building for community usage was presumed by the author during site visits. How does the community think of this decision, and what do they want to do about this building, are what needs to be clarified. The author has conducted a community need survey, which acquired the peoples' opinions and attitudes towards subjects such as "whether or not save the building", "selection for the best use for the building", and to "what are the desired facilities for the new use". The responding

ratio of this survey is unexpectedly high. These inputs from the community have been the fundamental information data for design programming and the overall process of this project.

<3> Setting specific design strategies

After the design program is completed, the author reviews the existing conditions of the old building, and evaluates different design models, with lessons learned from the precedent study. A general design solution is drawn and accompanied with specific design strategies, which account for every issues that may arise in the design process. The design relationship of preservation and new creation has been addressed.

<4> Focusing on solving problems and exploring potentials with the existing structure

Unlike new construction, this adaptive-use project has been based upon the existing conditions of IOOF Hall. The design decisions are made to solve problems that the existing building have (ie., such as circulation, fire egress, and space limitation). The potentials of the existing building (ie., such as large rooms, theatrical and exhibition space) have been recognized and utilized.

<5> Preserving the old and creating a sympathetic new

As a preservation effort, most of the deteriorated or modified exterior features of the existing structure are to be restored to the original design, as recorded in old photographs. For the interior features of the existing structure, demolition is done in such a way as to avoid the least radical change. Most of the materials culled from the partial demolition are to be recycled.

The new addition is designed to be respectful to the existing structure height, proportion, facade composition, and the materials used.

<6> Making a humane environment

Like most old buildings, the IOOF Hall is outdated, and has failed to provide modern people with a comfortable, humane environment. To adapt such a building into a cultural/recreational center for the community, it is necessary to satisfy the functional purposes, and meet the code requirements, and make it accessible to people of all ages, including those that are physically disabled.

Finally, although being hypothetical in nature, this thesis has drawn as much information resources as possible from inside the community, trying to be as realistic as possible. The author hopes that this adaptive-use design proposal would act as a reference for the effort of saving this building, and be of value for the revitalization of downtown Garnett.

BIBLIOGRAPHY

General References

- Abercrombie, Stanley Adaptive Re-Use, URBAN DESIGN, Spring 1977, Vol. 8, No. 1, pp. 34
- Abercrombie, Stanley GWATHMEY SIEGEL, Monographs on Contemporary Architecture, New York: Watson-Guption Publication, 1981
- Alexander, Christopher, et al. A PATTERN LANGUAGE, New York: Oxford University Press, 1977
- Blake, Peter Constabulary Reconsecrated, PREGRESSIVE ARCHITECTURE, November 1976, pp. 55
- Callender, John H., ed. TIME-SAVER STANDARDS FOR ARCHITECTURAL DESIGN DATA, New York: McGraw-Hill, 1974
- Diamonstein, Barbaralee REMAKING AMERICA: NEW USES, OLD PLACES, New York: Crown Publishers, Inc., 1986
- Fitch, James M. HISTORIC PRESERVATION: Curatorial Management of the Built World, New York: McGraw-Hill, 1982
- Harris, Cyril M. DICTIONARY OF ARCHITECTURE AND CONSTRUCTION, New York: McGraw-Hill Book Company, 1975
- Keister, Kim MAIN STREET MAKES GOOD, Historic Preservation, September/October 1990
- Kenyon, James B., FROM CENTRAL BUSINESS DISTRICT TO CENTRAL SOCIAL DISTRICT: THE REVITALIZATION OF THE SMALL GEORGIA CITY, Small Town, March-April 1989
- Lang, Jon T. CREATING ARCHITECTURAL THEORY, New York: Van

Nortrand Reinhold Co., 1987

- McKee, Harley J. INTRODUCTION TO EARLY AMERICAN MASONRY, Washington, D.C.: the National Trust for Historic Preservation, 1973
- McKee, Harley J. RECORDING HISTORIC BUILDINGS, Historic American Building Survey, U.S. Dept. of the Interior, Washington, D.C.: 1976
- Miller, Nyle H., et al, KANSAS: A PICTORIAL HISTORY, The Kansas Centennial Commission and the State History Society, Topeka, 1961
- National Trust for Historic Preservation OLD AND NEW ARCHITECTURE: DESIGN RELATIONSHIP, Washington D.C.: The Preservation Press, 1980
- Ross, Theodore A. THE ILLUSTRATE HISTORY OF ODD FELLOWSHIP, New York: The Ross History Co., 1913
- Sanoff, Henry METHODS OF ARCHITECTURAL PROGRAMMING, Stroudsbury, PA,: Dowden, Hutchingon & Ross, Inc., 1977
- Schmidt, Advin J. FRATERNAL ORGANIZATIONS, Connecticut: Greenwood Press, 1980
- Shields, T. J. and E. W. H. Silcock BUILDINGS AND FIRE, New York: Longman Scientific Technical, co-published with John Wiley & Sons, Inc., 1987
- Shopsin, William C. RESTORING OLD BUILDING FOR CONTEMPORARY USES: an American Sourcebook for Architects and Preservationists, New York: Whitney Library of Design, 1989

- Tournier, Robert E. HISTORIC PRESERVATION AS A FORCE IN URBAN CHANGE: CHARLESTON, in BACK TO THE CITY: ISSUES IN NEIGHBORHOOD RENOVATION, edited by Shirley B. Laska, et al., Pergamon Press, New York, 1980
- Ziegler, Arthur P. HISTORIC PRESERVATION IN SMALL TOWNS, A Manual of Practice, Nashville: American Association for State and Local History, 1980

Selected References

- Foerster, Bernd VISIT TO GARNETT, KANSAS, Kansas Society of Architects, AIA, Committee on Historic Resources, February 1990
- Garnett Planning Commission and City Staff Members, GARNETT ZONING ORDINANCE, City of Garnett, Kansas, May 1973
- Munson, C.T. and Associates, Planning and Design Consultants THE COMPREHENSIVE PLAN OF GARNETT, KANSAS, November 1972
- Rogers, Gilma OUR HERITAGE IN EARLY ANDERSON COUNTY, an Unpublished Booklet
- Urbas, Andrea ADAPTIVE USE DESIGN FOR THE BARTELL HOUSE HOTEL, JUNCTION CITY, KANSAS, a Master's Thesis, Kansas State University, Manhattan, Kansas, 1981
- Weisenburger, Ray B. LIST OF ISSUES CONCERNING DOWNTOWN RENOVATION AND PRESERVATION FOR GARNETT, KANSAS, September 1990

LIST OF DRAWINGS

<1> Measured Drawings

Figure 2-1. Measured Existing Site Plan	Page 34
Figure 2-2. Measured Existing South Elevation	Page 40
Figure 2-3. Measured Existing East Elevation	Page 41
Figure 2-4. Measured Existing First Floor Plan	Page 52
Figure 2-5. Measured Existing Second Floor Plan	Page 57
Figure 2-7. Measured Existing Third Floor Plan	Page 66

<2> Demolition Drawings

Figure 7-3. Demolition Plan: Third Floor	Page 139
Figure 7-4. Demolition Plan: Second Floor	Page 140
Figure 7-6. Demolition Plan: First Floor	Page 142

<3> Design Drawings

Figure 7-9. Proposed South Elevation	Page 145
Figure 7-10. Proposed East Elevation	Page 147
Figure 7-11. Proposed First Floor Plan	Page 149
Figure 7-12. Proposed Second Floor Plan	Page 150
Figure 7-13. Proposed Third Floor Plan	Page 152
Figure 7-14. Proposed North Elevation	Page 153
Figure 7-16. Proposed North-South Section	Page 155
Figure 7-17. Axonometric Section	Page 156
Figure 7-19. Detailing of South-Stairway Entry	Page 159

Figure 7-20. Detailing of Exhibition
Arch on the Second Floor Page 160

Figure 7-23. Proposed Site Plan Page 165

Figure 7-24. A Perspective View
From the Courthouse Square Page 163

**ADAPTIVE-USE DESIGN FOR THE IOOF HALL
IN GARNETT, KANSAS**

by

LICHANG JIN

B. Arch, Tianjin University, CHINA, 1981

Master of Urban Planning & Design, Tianjin University, CHINA, 1985

AN ABSTRACT OF A MASTER'S THESIS

Submitted in partial fulfillment of the
requirements for the degree

MASTER OF ARCHITECTURE

College of Architecture and Design

**KANSAS STATE UNIVERSITY
Manhattan, Kansas**

1992

ABSTRACT

The IOOF Hall is a three-story brick and stone building, built in 1883 in downtown Garnett, Kansas. In its early days, it housed a bank on the first floor, stores and offices on the second floor, and the IOOF organization on the third floor. The building is vacant today except for a small corner on the first floor occupied by a real estate office.

Located at the north-west corner of the Courthouse Square, this building has been the oldest, the second highest, and better preserved structure, in both the exterior and interior, in the downtown area. This building initiated the community's effort of "painting up the downtown". It has been considered as a crucial element in downtown revitalization. Yet, merely painting it up is not the solution to saving this building and using it to help revitalize the downtown area. A community needs survey, conducted by the author, shows that the people living close to the downtown area would like to renovate this building and use it as a community center for cultural and recreational facilities. The survey results indicate that an adaptive-use proposal is well accepted by the community as being a feasible way of rehabilitation.

Unlike new construction, the adaptive-use design for the IOOF Hall, as a cultural/recreational center for the community has to be based upon the existing condition of the building. Both the programming process and design phase refer the findings of the problems and potentials of the existing structure. It is realized that building an addition to the north of the building can not only

provide enough space needed for the proposed usage, but can also address the issue of circulation and fire egress in the existing building. This addition is to be three stories, the same height as the existing structure, and compatible with its proportions, facade composition, and materials used. All the exterior and most of the interior features of the existing structure are to be restored to their original design, and materials culled from the partial demolition are to be recycled.

With the addition providing a main entry, a vertical circulation core, a transitional lobby, restrooms, and other auxiliary spaces, new functions have been assigned to each floor, ie., a community assembly room on the third floor, arts and crafts exhibition space on the second floor, and physical fitness and game rooms on the first floor. This cultural/recreational center is designed to be a barrier-free environment, and to be used by people of all ages.