

**DESIGN OF A UNIVERSITY CAMPUS**

by

**HOMER LEROY PUDERBAUGH**

**B. Arch., Kansas State College of  
Agriculture and Applied Science, 1952**

---

**A THESIS**

**submitted in partial fulfillment of the**

**requirements for the degree**

**MASTER OF SCIENCE**

**Department of Architecture**

**KANSAS STATE UNIVERSITY  
OF AGRICULTURE AND APPLIED SCIENCE**

**1959**

LD  
2668  
T4  
1959  
P85  
c.2  
Document

TABLE OF CONTENTS

INTRODUCTION . . . . .	1
PURPOSE . . . . .	2
BACKGROUND . . . . .	4
Beginning of Universities . . . . .	4
Planning . . . . .	9
The Problem . . . . .	11
PHYSICAL ARRANGEMENT . . . . .	18
Space . . . . .	18
Orientation . . . . .	33
Vehicular Traffic and Parking . . . . .	60
Pedestrian Circulation . . . . .	70
Building Groups . . . . .	72
Building Arrangements . . . . .	76
AESTHETICS . . . . .	95
Space . . . . .	95
Relationships . . . . .	97
APPLICATION . . . . .	122
CONCLUSION . . . . .	132
ACKNOWLEDGMENT . . . . .	134
REFERENCES . . . . .	135
APPENDIX . . . . .	139

## INTRODUCTION

The goal of planning is to obtain a logical solution to a problem; the goal of campus planning is to develop a better physical plant in order to create the environment necessary and conducive to learning and research. Planning is a decision making process and plans are the product of these decisions. Plans, as a product, are only valuable when used as guides to physical development and improvement. To achieve the campus necessary in the future, there must be a well defined idea of the purpose and need for a university. Administrative decisions must be made and basic philosophies determined. To give scope and definition to these decisions, questions must be raised and answered at all planning levels to establish the primary goals of the university.

Basic studies of educational conditions and needs set the limits of planning objectives. These studies balance future needs against future resources and propose alternatives by which decisions can be made. These basic studies provide a factual basis for making decisions about the university and its physical plant.

To guide development and to avoid mistakes in the future, the interrelationships of plans and physical development must be understood. Land use affects the needs for services, facili-

ities, access and density. One of the objectives of planning is to coordinate plans and programs to prevent the costly mistakes of location, timing, and construction, and to provide orderly progress toward the final development.

The objective of preparing plans is to provide a guide for the campus development and improvement toward a predetermined goal. This goal is stated in terms of principles, standards and generalized development patterns. A comprehensive master plan must contain statements of planning objectives, principles and standards, and how these are applied in the preparation of the plans. The "why" and the "how" are at least as important as the drawing of the master plan since they explain how they are justified and why in that particular place.

#### PURPOSE

The purpose of the research presented in this thesis is two-fold: first, to establish a basis of space relationships between buildings and building groups as a criteria of design, and second, to show how this criteria is resolved into an actual physical creation based on space recognition and its relations to other design elements.

Design, as a creative attempt, is a process of intellectual adaptation of given conditions into an aesthetic effect. Whether this is judged by a set of values or not is incidental

to the process of the original creation. As a process it is affected by intellectual conditioning and knowledge of design concepts. The results of any creation are dependent upon the designer's knowledge of basic design and his ability to use his imaginary senses in a logical and sequential pattern. This ability and knowledge must include a recognition of spatial concepts as a primary design element.

The arrangement of buildings into groups and the composition of groups into a final unity must include many complementary and conflicting factors, and the final solution will be a compromise of these many factors. Such factors as density, enrollment, sex ratio, marital status, pressures from society and educational trends can not be accurately predicted. Orientation, sequence of construction, building funds, functional relationships, available land space, and inter-college necessities are factors which may have to be considered. Scale, harmony, unity, character, rhythm, proportion, style and space are factors which must not be compromised regardless of purpose, intent or cost.

The campus plan presented is a solution which attempts to establish functional relations in a space-time problem. It is not said nor inferred that this is the only solution, but rather that this is a solution which accomplishes the criteria established and is offered as a base for further development and study.

## BACKGROUND

### Beginning of Universities

Universities are a product of the Middle Ages. The Greeks and the Romans did not have universities in the present sense of the word. They had schools of higher education in law, rhetoric, and philosophy, but these were not formed into permanent institutions of learning. It was not until the twelfth and thirteenth centuries that there emerged

...those features of organized education with which we are most familiar, all that machinery of instruction represented by faculties and colleges and courses of study, examinations and commencements and academic degrees. In all these matters we are the heirs and successors, not of Athens and Alexandria, but of Paris and Bologna. (Haskins, 12), p. 2.

These early medieval universities had no libraries, laboratories, or museums, no endowments or buildings of their own. They did not have boards of trustees or regents, they published no catalogues, there were no student societies, no dramatics, no athletics and no "outside" activities which are so prevalent in American universities today. Universities consisted of students, teachers and a desire. And yet with these great many differences, the twentieth century university is a lineal descendant of Paris and Bologna.

The beginning of universities is obscure and lost in history. Actually in many cases these were not firmly established

at a particular date by a particular person, but simply "just grew" arising slowly and quietly without a definite record or course of action. The occasion was a great revival of learning in the twelfth century which occurred because of the great influx of new knowledge into western Europe, partly through Italy and Sicily, but chiefly through the Arab scholars of Spain. This knowledge included the works of Aristotle, Ptolemy, Euclid, and the knowledge of Greek physicians, and texts of Roman law that had lain idle through the Dark Ages. This new-found knowledge in plane and solid geometry, arabic numbers, logic, metaphysics, ethics, and law and medicine broke the bondage of cathedral and monastery schools and created the university, a society of masters and scholars. At this time, there is found the sudden growth of the University of Oxford, the University of Paris, the notice given the medical university of Salerno, (which had existed as early as the middle of the eleventh century) and the many sided university of Bologna, which became most noteworthy for the revival of the Roman law. By 1158 Bologna had become the academic home of some hundreds of students bound together for mutual protection and assistance. Bloomfield states that "in A.D. 1262 at Bologna the faculties were lecturing to ten thousand students - twice as many students as there were people living in the town." (Bloomfield, 31), p. 100. Unification was desirable for protection from the

town people, who were prone to exploit these students, and protection against the "masters" (teachers) to ensure bona-fide lectures, examinations, and qualifications. The teachers' fees were entirely paid by the student, and these students were most concerned that the teacher performed his duties and did not leave before fully delivering his lectures. Rules and regulations were established by the "universities" (student bodies) governing the attendance of the teachers, insuring that his subject matter was sufficient, that he would cover all his subject without skipping chapters, and generally insuring that his performance would be equivalent to the fees collected. Being excluded from the "universities", the professors formed guilds or "colleges" to protect themselves from unworthy students by demanding certain requirements for admission and requiring that the student seek the professor's license as a certificate of attainment.

By the beginning of the twelfth century the center of learning is no longer confined to monasteries but has moved to schools attached to cathedrals such as Liege, Rheims, Loon, Paris, Orleans, and Chartres. The cathedral schools failed to survive, however, and, as in the case of Chartres, by the time the cathedral was finished, the center of learning had moved to Paris, some fifty miles away. Because of its geographical loca-



tion, its political significance as the capital, and its brilliant teachers, the cathedral school of Notre-Dame in Paris became the core for northern Europe and the Low Countries. Before the end of the twelfth century Paris ceased to be a cathedral school and became a university of thirty thousand students.

In this twelfth century university at Paris began an institution that exists to this day, the college. The college, as distinguished from the professors' guild, was originally an endowed hospice or residence hall. The college was early accepted as a definite part of academic life. "The object of the earliest college founders was simply to secure board and lodging for poor scholars who could not pay for it themselves." (Rashdall, 20) The colleges had buildings and endowments and were easily absorbed into the university life and teaching. There is record of a college in Paris as early as 1180, and there were sixty-eight by 1500. This system and these buildings survived until the French Revolution, which left only fragments of buildings or names. Many other universities had their colleges (the ancient College of Spain at Bologna survives today), but the ultimate was reached in the colleges of Oxford and Cambridge.

Paris was the model and source of many other universities. Oxford modeled after Paris in the late twelfth century, and somewhat later Cambridge followed suit. In 1386 the University of

Heidelberg was founded, a direct imitator of Paris. There were at least eighty universities founded in different parts of Europe by the end of the Middle Ages. Many were short-lived, others were of local importance only, some were to flourish and then die, while others like

...Paris and Montpellier, Bologna and Padua, Oxford and Cambridge, Vienna and Prague and Leipzig, Coimbra and Salamanca, Cracow and Louvain, have an unbroken history of many centuries of distinction. And the great European universities of more recent foundation, like Berlin, Strasbourg, Edinburgh, Manchester and London, follow in their organization the ancient models. In America the earliest institutions of higher learning reproduced the type of the contemporary English College at a time when the university in England was eclipsed by its constituent colleges; but in the creation of universities in the later 19th century, America turned to the universities of the Continent and thus entered once more into the ancient inheritance. Even in the colonial period a sense of the general university tradition survived, for the charter of Rhode Island College in 1764 grants the same privileges, dignities, and immunities enjoyed by the American colleges and European universities. (Haskins, 12), p. 20.

Our inheritance from the oldest universities is not buildings nor type of architecture. The early universities did not have any buildings of their own, but used instead private lecture halls and neighboring churches, and as late as 1775 the First Baptist Church in Providence was built "for the public worship of Almighty God, and also for holding Commencement in." (Haskins, 12), p. 21. Salerno offers no monuments of its university architecture. Bologna's remaining university architecture dates from the fourteenth century. Both Montpellier and

Orleans have preserved nothing from this early period, and Paris can offer only the church of Saint-Julien-le-Pauvre, where lectures were held, and the cathedral in the city. The best Cambridge monument, Kings College chapel, is of the late fifteenth century. Only at Merton, which set the college type at Oxford, do any of the present structures date back of 1300. Oxford's Bodleian library, the tower of Magdalen and the hall of Christ Church all belong to the Tudor period, more akin to modern than mediaeval. Thus our inheritance lies in the universities institutions, rather than its form, its function and its architecture. A university's existence did not depend upon its own physical plant but rather upon its students and faculty. Existing structures such as monasteries, cathedrals and vacant halls served as its physical containment. What architectural style and form existed was ecclesiastical by its very nature, being church first and school second.

### Planning

It hardly seems necessary to advocate the need of planning, inasmuch as most professionals are in agreement that it is desirable. The extent and degree of planning seems to be the real question. The thought process necessary in the solution of problems is a form of planning. Both factual and value questions

and answers arise in making decisions, and this very act is planning.

Planning is not the sacred property of one field or group of people, but encompasses many professional fields and areas of study. At a recent National Construction Industry Conference, sponsored by the Armour Research Foundation of the Illinois Institute of Technology, there was found to be considerable disagreement on the aspects of planning as it applies to the city. All groups were in agreement that a city must plan but seem to be in disagreement as to the means of implementing the actual planning.

Social Scientist: Design the city to meet human needs. Architect: Design it to meet the needs of modern auto traffic. Engineer: Design it with the new shapes we can offer. Contractor: Design it so we can build it. Planner: Build the city, don't just talk about it. (Engineering News-Record, 35), p. 21.

This conference clearly shows the wide spread lack of coordination and cooperation that apparently exists between these fields so vitally associated, and closely related in the common field of planning.

Planning means "to devise or project as a method or course of action; to prearrange the details of" (Webster, 30). Planning in this thesis has been restricted to a university campus and there further restricted to the physical plant of that campus. The planning of the curriculum, the courses, the room schedules

are the particular problems of those individuals involved in a specific field and will not be considered; the planning of finances, scheduling of construction dates, of economic feasibility and enrollment data will also be left to those confronted with the specific problems, and the actual placement of physical structures on specific campuses will be left to those architects, engineers, and campus representatives who are receiving fees adequate to cover their professional considerations, and who have all the facts, figures and technical data pertinent to their campus.

#### The Problem

The value of advanced planning is obvious, after the error has been committed. Too many campuses are living evidence of poor planning: crowded classrooms, over used buildings, too little land space, unrelated and random located buildings, hordes of automobiles and acres of black top parking, with the demand for more area and services ever increasing. Fifteen years ago campuses that were outside the city with acres of farmland adjacent to their own large, scantily populated property are today in the midst of residential areas, and are restricted in further growth by a lack of available property into which they could expand. The experts have either failed in their prediction of college needs or merely ignored the problem. Recommendations by

administrators to the boards of regents to buy additional property were ignored, and today we suffer from this decision and ponder the results of today's decisions for tomorrow. Adequate planning fifteen years ago would have alleviated part of this problem. Adequate planning now will not remove these errors, but it will at least minimize these mistakes and prevent similar future blunders.

With enrollment predictions increasing each year, the university must either make plans for the physical control of the campus, or it is going to crowd itself into highly congested, non-flexible areas that cannot and will not accommodate the multitudes. Many schools have embarked on huge fund-raising programs for building purposes, have aroused the public to their physical needs, are inspiring the alumni to work increasingly hard for the good of the cause, and have created staffs and given the task of promotion to the professional fund raisers. Yet what degree of advanced planning preceded this campaign? Probably very little, if any.

Looking at alumni magazines one sees two-page spreads of the "Campus of the Future", long articles expounding on the quantity of new and proposed buildings, the maze of new streets, and the need of more athletic scholarships. An analysis of the proposed campus shows evidence of either ignorance in the initial stage

or a lack of concern by an uninformed administration.

Viewing today's campus one can easily criticize past mistakes without giving consideration to those who made the decisions. Some planning with good results is evident in excluded areas. Groups of buildings are well arranged and function with each other successfully, and this must be a criteria for further development.

It is believed (by this writer) that campuses cannot expand sufficiently to meet further demands and there will have to be a diverting of students to other institutions and in some instances the creation of new campuses, either as separate institutions or as separate segments of existing colleges. Either way we return to planning - planning in the decision of where and how to handle the physical structures that will be necessary. The primary purpose of campus planning is to build a better campus. Basic studies in enrollment, marital status, ages, conditions and trends establish planning objectives. They provide a factual basis for making decisions about campus development, balance future needs against existing conditions, and allow for decisions and alternatives to be made. To avoid future mistakes and to guide in the development, the planner must understand the interrelationship of plans and decisions for physical development. The placement of a building affects the needs of services,

facilities, traffic and congestion. Campus density can be radically changed by the location of a single building. In a university where the engineering enrollment is twenty-five per cent of the total enrollment, the placement of a new engineering building will affect as much as one-fourth of the total enrollment density. Pedestrian traffic patterns fluctuate, and as departments change classroom locations, so does the flow of students change. A value in planning results when administrative programs are co-ordinated with the building plans to prevent costly mistakes of location, timing, construction and usage. The objective of preparing plans is to provide a guide for campus development toward a predetermined goal, a goal that must be stated by the administration in terms of principles, standards, and generalized development. The time period over which effective projections can be made is limited. This is caused by changing needs, changing philosophies and the fallibility of statistics; however, once the plans are formulated and developed, there is a distinct limit to their flexibility. It is obvious that since plans are based on predictions, estimates and projections of future needs, that a periodic re-examination is necessary; but it must be recognized that the change in any one element, even if it might be justified in itself, may disturb its relation to the other elements of the plan and thereby destroy much that has been created and accomplished.



Poor planning versus no planning -- this is the general case as planning is related to today's university. Poor planning here denotes the university's lack of qualified people to develop the future physical plant. Most schools have a maintenance department or buildings and grounds department or other similarly named service department, but few if any maintain a full time professional planner or at least a part time consulting firm. Here we have a multi-million-dollar-a-year industry whose finished product is education, attempting to maintain and further develop a physical plant with the use of student counseling personnel as the liaison between the university and the outside architect - an industry whose very foundation is based on its preaching of honesty, integrity, service and development of professional people, yet which practices deceit by the spending of allocated tax money without planning and supervision. Condoning this lack of planning as economical and thrifty and allowing the community to encroach on its premises and then later crying for more space and buildings is a disservice to the community. There appears to be a direct disregard for the professional personnel on its faculty and staff in granting the powers of decision to a committee or committees composed of those least qualified to make these decisions, in appointing committees of people chosen on the basis of seniority, rank,

desire to be committee members, and intra-university politics, and ignoring directly and purposely those who are professionally trained in planning.

The committee system is a great democratic American institution of the politician. This system is a means by which the university subjects itself to mediocracy. No creative work has ever risen above the level of the abilities of those who created this work, and no university can hope to rise above the collective thinking of its committees.

In no business, except the United States Government, can so many well qualified people in various fields be found concentrated in such a small area, and in no business, except again the United States Government, is there such a complete disregard for the use of these intellectuals.

Occasionally a school will call in an "expert" to advise them on future developments. In many schools this is a laudable step toward good planning; in others this is a political step in fulfilling an announced fund-raising campaign; and in still others this is a disregard of the equally or better qualified personnel already on the campus and well acquainted with its problems and desires. This is not saying the committees should be banned. Many committees, under capable and strong leadership, have made decisions that show good results and are to be commended for

their productive work. Committees whose membership contains planners are more likely to be successful in their planning decisions than those committees which do not contain planners. This is obvious. The university leadership must provide and insist on good planning. In a hierarchical arrangement this is where the final decision is made and must be where the final responsibility is placed. There is no choice between poor planning and no planning. The results of both are disastrous and there are fifteen-hundred universities and colleges to supplement this statement. Every author on city planning decries the state of the American city and pleads for action to remedy this appalling situation. Unless the universities awake to their present condition and correct the direction of this rapid growth, they too will find themselves at a point of no return.

N. L. Engelhardt, Sr., writing in the A.I.A. Journal, states that the schools belong to the people, that they are entitled to participate in school planning.

In our form of society the people themselves have a right to decide the kind of educational organization that will be advanced for their children, and the kinds of schoolhouses that should be built to meet the demands of the organization. (33), p. 37.

The writer would take radical exceptions to this statement. To allow the people to make these decisions is to have the decisions not made at all or at best to have a decision made that

will result in failure. This is an age of specialization and such generalizations as society is capable of making are of little value in arriving at planning solutions. The planners should keep the people informed but this does not mean he must allow them a real part in these highly specialized decisions. Today's campus is a result of the people's decision. When no planning advice was available, the people (committee) made the decisions and their results show in the illogical, ill-arranged, non-functioning, heterogeneous scattering of buildings. The results are poor enough when the decisions are made by educated campus people, without allowing the disinterested, ill-advised, non-specialized public to make these decisions. What little progress has been made in the last century is the result of having planners and architects make the decisions, and to give this power to the public will result in complete regression. Campus planning is a specialized field and there is little room for the non-specialist.

#### PHYSICAL ARRANGEMENT

##### Space

The physical arrangement of buildings and building groups on a campus is primarily an exercise in spatial considerations. While there are many considerations which should influence the

choice of the final location, the realization of the function, orientation, and inter-relationships of buildings and open spaces should be and must be initiated during the preliminary studies and maintained throughout the entire design stages if the final result is to be successful. Haphazard locations will prove to be unsatisfactory and undesirable relations will result. Spaces must be recognized as entities, as a substance about which buildings are to be arranged, not as a void into which buildings are placed. The idea that "here's an empty space, let's put a building in it" has too long prevailed as the campus design criteria. Mediocrity breeds mediocrity and failure to acknowledge space breeds disorder or confusion, a common result in campus plans.

Space itself is a dynamic condition and so the ideas concerning it are in a dynamic state. History shows that ideas of space and its relationships in design have undergone constant changes. Architects must increase the understanding and knowledge of space if they are to solve its many perplexing problems in organization for human needs. Man, Space and Architecture--the triad which cannot function except in unity. Remove one and the others dissolve, for they have no purpose.

Inasmuch as the concern of this thesis is with building relations as a campus function (space and its various architectural

relations), area and space are emphasized in all the drawings. No attempt is made to represent the architecture except to show the area relating to it.

It is the conviction of this writer that space is the basis for all relationships between buildings in a group and between groups in a whole; that while there are many considerations to be given to campus design, the functions of the other elements are related through the spatial considerations. It is not denied that the other elements of good design play an important role, even contribute heavily to the success or failure of the architectural design, but their relations are functions of space and time and as such are subordinated to space-time theories. It is this firm belief that causes the emphasis of this thesis on campus planning to center around the only criteria to be logically established for analysis, consideration and judgement of the functions and arrangements of structural groups and the resulting effect they create in the spaces they occupy.

The methods of representing buildings and spaces most frequently employed in explanations of art and architecture consist of (1) plans, (2) facades and elevations and (3) photographs. Neither singularly nor together can these means ever provide a complete representation of architectural space. However, in the absence of a thoroughly satisfactory method, the privilege of

entering into and experiencing space, it becomes necessary to study the various relations with whatever techniques are available. No attempt to show volume of exterior spaces is made in these drawings as it is felt it would prove inadequate and confusing.<sup>1</sup> Where a comparison is drawn between diagrammatic illustrations and actual architectural groupings, the reader is asked to refer to any of the many reference books which contain photographs and drawings to complete his study of that particular grouping.

Every period of architectural development has its own conception of building relationships and spatial organization; however, there is a lag between its conception and its realization and understanding by the people of that period. This is the case with today's spatial conception. What is known of "space" in general is of little help in grasping it as an actual entity and an element of function and design in building groups. The use of words like rhythm, scale, balance, mass, are vague and will continue to be vague until they are given meanings specific to the reality which defines architecture: that is, space.

It is known that space is a reality of sensory experience. It is a human and animal experience and a means of expression. Space as a reality, once it has been comprehended in its essence,

---

1 See appendix for all drawings and plates.

can be grasped according to its own laws and arranged according to them. Man has constantly tried to use this reality (i.e. this material) in the service of his urge for expression, no less than the other realities which he has encountered. Space expression is not a privilege of gifted architects, artists, designers and planners, but a physiological function of everyone. The biological base of space experience is everyone's endowment, just as is the experience of color or tone. By practice and suitable exercises, this capacity can be developed and extended. To be sure, there will be many degrees of difference, from minimum to maximum capacity, but basically space experience is accessible to everyone, even in its rich, complicated forms. The ability to grasp this concept is of the greatest help in conceiving any design.

Space is nothing, an undefinable void, uncomprehensible matter, until the sensory preceptors detect a point of reference, then it becomes containing environment. The eyes search through space for a point to focus upon, and finding this point one becomes aware of spaciousity. Space is the element through which man moves and within which he builds the pattern of his life. It is the light and air he encloses in sheltering walls, the surface on which he projects images.

Matter is fashioned; space comes. Space is nothing-- a mere negation of the solid. And thus we come to overlook it.



But though we may overlook it, space affects us and can control our spirit; and a large part of the pleasure we obtain from architecture--pleasure which seems unaccountable, or for which we do not trouble to account--springs in reality from space. Even from a utilitarian point of view, space is logically our end. To enclose a space is the object of building; when we build we do but detach a convenient quantity of space, seclude it and protect it, and all architecture springs from that necessity. But aesthetically space is even more supreme. The architect models in space as a sculptor in clay. He designs his space as a work of art; that is, he attempts through its means to excite a certain mood in those who enter it.

What is his method? Once again his appeal is to Movement. Space, in fact, is liberty of movement. That is its value to us, and as such it enters our physical consciousness. We adapt ourselves instinctively to the spaces in which we stand, project ourselves into them, fill them ideally with our movements.

We cannot, however, lay down fixed proportions of space as architecturally right. Space value in architecture is affected first and foremost, no doubt, by actual dimensions; but it is affected by a hundred considerations besides. It is affected by lighting and the position of shadows: the source of light attracts the eye and sets up an independent suggested movement of its own. It is affected by color: a dark floor and a light roof give a totally different space sensation to that created by a dark roof and a light floor. It is affected by our own expectancy: by the space we have immediately left. It is affected by the character of the predominating lines: an emphasis on verticals, as is well known, gives an illusion of greater height; an emphasis on horizontals gives a sense of greater breadth. It is affected by projections--both in elevation and in plan--which may cut the space and cause us to feel it, not as one, but several. Thus, in a symmetrical domed church it will depend on the relation of the depth of the transepts to their own width, and to that of the span of the dome, whether we experience it as one space or as five; and a boldly projecting cornice may set the upward limit of space-sensation instead of the actually enclosing roof.

Nothing, therefore, will serve the architect but the fullest power to imagine the space-value resulting from the complex conditions of each particular case; there are no liberties which he may not sometimes take, and no "fixed ratios" which may not fail him. Architecture is not a machinery but an art; and those theories of architecture which provide ready-made tests for the creation or criticism of design are self-condemned. None the less, in the beauty of every building, space-value, addressing itself to our sense of movement, will play a principal part. (Zevi, 27), p. 216.

The capacity to see two things in relation to each other depends on the awareness of a third--the size and shape of the space between them. Intervals of space are as much a part of visual design as the silences between sounds in music are part of the aural design. Spaces have form. In Henry Moore's "Reclining Figure" the artist has worked with the space around the sculpture as well as the material itself. Space even moves through it.

Space according to Webster is:

(1) That which is characterized by extension in all directions, boundlessness, and indefinite divisibility; that in which all physical things are ordered and related at one time (or apart from time). (2) A limited extension in one, two and three dimension; a part marked off or bounded in some way; distance, area or volume. (Webster, 30)

Space-time according to Webster is:

The 4th-dimensional order within which every physical existent may be determined or "located" by specifying its four co-ordinates, three spatial and one temporal; also, the characteristic quality, or set or properties, of such an order. (Webster, 30)

The illusion of space may be created on a flat or two-dimensional surface by (1) Superimposed shapes (Plate I, Fig. 2): although these two squares are the same size, one appears to be in front because its outline overlaps the other and obliterates part of it. (2) Linear perspective (Plate I, Fig. 3): Lines appear to converge and objects grow smaller or larger as they recede or advance. (3) Contrast of light and dark (Plate I, Fig. 4): (value) One of these squares advances by the power of its stronger contrast to the background. (4) Relationship of colors (Plate I, Fig. 5): When several colors are seen together some may appear to advance nearer to the observer than others.

A definition of space which may be taken as a point of departure is found in physics, "space is the relation between the position of bodies." Therefore: spatial creation is the creation of relationships of position of bodies (volumes). On the basis of volume analysis, we can understand bodies, whether large or minute, in their smallest or most grand extensions. The definition of course must be tested by the only means with which space is grasped, that is by sensory experience.

Each of the senses which perceives the position of bodies helps us to grasp space. Space is known first of all by the sense of vision. This experience of the visible relations of bodies may be ascertained by movement--and by the alteration of

one's position. Other means of experiencing space lie in the organs of hearing and balance. Man perceives space through:

(1) The sense of sight in such things as areas formed by surfaces meeting and cutting one another; interpenetrating objects; through the relationship of masses, implemented by light, shadows, transparency and color. If the planes (Plate I, Fig. 1) of a volume are scattered in different directions, spatial relationships originate and become apparent. A "section of space" (area defined by a volume) is cut out of "cosmic" (omni-existing) space by a network of solids, just as if space was a divisible compact object. Planes give surface directions in space. Most surfaces can be seen in terms of planes. A brick wall, which appears as a continuous curve, is actually made up of a multitude of flat surfaces. A house is composed of living spaces defined by planes: the wall, the floor, the ceiling. The eyes automatically connect points in space. If sight were no more than the one-by-one perception of isolated points one would never recognize objects in their entirety. As the eyes move swiftly from point to point they are able to assemble a total image out of a multitude of details.

(2) The sense of hearing by reflected sound, echos and stereophonic sound. In complete darkness one is aware of surrounding surfaces. Their very presence can be "felt." Sounds

describe distances along with direction. Volume as a function of aural preception helps in defining the nearness or farness of surrounding objects. The degree of development of aural preception is dependent on the use of visual preception. The loss or lack of the visual sense tends to magnify and increase the sensitivity of the aural sense. Electronic devices can recreate or produce sound and effects that create aural sensations with positive depth and distinct direction and sound. Sound is a vector quality with both direction and magnitude. A voice speaks, a car passes, a typewriter clicks and sound waves are created which expand to fill their confined area or expend themselves and diminish. Sound waves strike surfaces and are absorbed or reflected or both. In any well designed auditorium the acoustics allow the source of the sound to be ascertained without visual aid. Sound as the stimulant and hearing as the sensation are dependent upon the space within which the vibrations react. Music is the greatest of all sound stimulants, its whole being is used as an aural experience.

(3) The sense of equilibrium by circular motion, curving ramps and spiral stairways. Equilibrium is maintained and direction changes sensed by the movement of the fluid in the inner ear. Without visual or aural perception this sense of equilibrium is maintained to a limit. Motion sickness is caused by

the unaccustomed, sudden, rapid and frequent changes in directions of movements to which the body is not normally exposed. Vertigo is an extreme condition of this type of experience. Yet with intermittent, sudden changes in elevation, direction and altitude can enhance and greatly add to spatial experiences and pleasures. This is the least sensitive of all our space preceptors, dependent upon an association with visual and aural.

(4) The means of movement by different directions in space (horizontal, vertical, diagonal); intersections, repetitions and undulations; movement created by an interplay of design elements. A physical change creating through the visual and aural senses a change by differences in depth, light and dark, shade and shadow, and bright and dull surfaces. Aural excitement by using echoes and reverberations that are soft and loud, and near and far.

(5) The sense of touch through various textures and mixtures of materials. Rough against smooth, slick against abrasive, and soft against hard.

A solid mass is often independent of the space around it. Thus, simple massive forms are among man's greatest visual achievements. One can feel the power and massiveness of the pyramids, the Lincoln and Jefferson Memorials and the Washington Monument.

Volumes are interior spaces. Space can be shaped just as mass is shaped. In cupping the hands one not only forms the outside shell, but also gives size and form to the contained space. A room is a volume. The walls, ceiling and floor describe the limits of the interior space. An exterior court is a volume. The facades, eaves and ground describe the limits of the exterior space.

Transparency is a means to gain lightness and visual or psychological space. A transparent wall allows the outdoors to unite visually with the indoors, without sacrificing protection against the elements. Transparent materials tend to make buildings seem open and more spacious.

The root of architecture lies in the mastery of the problem of space; its practical development lies in technological advances. Architecture will be brought closer to its fullest realization when the deepest knowledge of human life is conceived and manifested in one of its most important components: the consideration of man in space. Space creation is an interweaving of solids and voids in clearly traceable relations extending in all directions as a fluctuating play of forces.

Spatial experience, however, is limited, because any sensual experience is directly proportional to the sensitivity of the receptors. Those receptors which are highly trained will

be more sensitive to subtle stimulants, and those which are least trained will lack the finesse to recognize and appreciate that which has been accomplished.

A man standing free in a limitless desert cannot perceive the huge void in which he is contained (Plate II, Fig. 1). Without a point of reference he is lost. His senses for space recognition cannot function. Space is all and all is space. But let the wind weave a pattern in the sand around him and he can see (and maybe feel) an imaginary barrier that begins to form a definite space (Plate II, Fig. 2). He can now sense containment within the limits of the pattern. On this same limitless desert erect a few vertical posts around him and a definite barrier is suggested (Plate II, Fig. 3). A containing space has been established that is no longer imaginary but strongly suggested. Space can move in and out, but spatial definition is established. Replace these vertical posts with a solid wall and the person at once perceives real confinement by a real barrier (Plate II, Fig. 4). It defines a space that is real, that can be seen, felt and heard, a definite space within an indefinite space, spatial definition recognizable to all the senses of perception.

The experience of space (a characteristic of architecture) has its extension in the city, in the streets, squares, alleys



and parks, in the playgrounds and in the gardens, and on the campuses, wherever man has defined or limited a void and so has created an enclosure. It is doubtful whether the experience of space one has in riding in an automobile along a straight highway through miles of uninhabited flatland can be defined as an architectural experience in the present use of the term, but it is certain that all urban space, wherever the view is screened off, whether by stone walls or rows of trees or embankments, presents the same features found in architectural space. Whenever a complete experience of space is to be realized, man must be included, he must feel himself part and measure of the architectural organism.

All the techniques of representation and all the paths to architecture which do not include direct experience are pedagogically useful, of practical necessity and intellectually fruitful; but their function is no more than allusive and preparatory to the moment in which we, with everything in us that is physical and spiritual and, above all, human, enter and experience the spaces we have been studying. That is the moment of architecture. (Zevi, 27), p. 60.

Isolated forms unrelated to each other become random masses and volumes. These masses diffused on a plane surface create an incoherent pattern. Instinctively one wants to rearrange them until the sense of order and balance is satisfied. Order comes with planning. On any campus, intelligent planning provides ample living space, recreation and working areas, safe

and convenient thoroughfares. Buildings thrown together like leaves scattered by the winds fail to accomplish this purpose. Thus architecture and campus planning become problems of spatial design in terms of human needs.

The present spatial concepts have been developing for many centuries. A close look at the history of architecture will show that man has constantly been plagued by his own efforts to express his feeling for space. First in Europe and later in America he was and is still attempting to conquer and express his ideas of space. What is felt today is probably just one phase in a long succession of spatial concepts. While the western world was developing its ideas and methods of expression, by communication with the cultural centers of Europe (Paris, Florence, Rome, etc.) the Japanese with their "closed-doors" policy, were arriving at spatial concepts in the tenth century that parallels the organic conception that the west "found" around 1900. Although not all designers are in agreement as to the architectural and artistic means of expressing this new-found concept of space, the Japanese, without outside influence, developed their own feeling about the creation, moulding, and use of space.

Since every architectural volume, every structure of walls constitutes a boundary, a pause in the continuity of space, it

is clear that every building functions in the creation of two kinds of space: its internal space, completely defined by the building itself, and its external or urban space, defined by that building and the others around it. While it is incontestable that beautiful decoration will never create beautiful space, it is also true that a satisfactory space, if it is not complemented by an adequate treatment of the walls which enclose it, is not sufficient to create an aesthetic environment. Even if the other arts contribute to architecture, it is space, the space which surrounds and includes man, which is the basis for the judgement of a building, which determines the affirmative or negative of aesthetic pronouncement on architecture. All the rest is important or perhaps one should say can be important, but always in a subordinate relation to the spatial idea. That space should be the protagonist of architecture is after all natural. Architecture is not art alone, it is not merely a reflection of philosophy of life or a portrait of systems of living. Architecture is environment, the stage on which man's life unfolds.

### Orientation

Orientation in psychology means the ability to locate one's self in one's environment with reference to time, place

and people. While this definition may cover the entire field and leave little more to be desired, the specific application here refers to the natural elements. The adaptation of the physical structure must utilize these natural elements to its own advantage and must be protected from those elements that are undesirable and harmful. Since man first climbed down out of the trees and searched out a cave, he has been concerned with orientation. Even then he probably found it more enjoyable to occupy a cave which afforded him some protection from the rain and wind, allowed the warm sunshine to enter, and had enough cracks, crevices and holes to give some form of ventilation. Primitive, yes; basic, yes; and yet as applicable today as in the year one.

The problems and concern then becomes one of determining what factors control orientation, and how to subject the structure to them. While great sums are spent trying to obtain superficial devices as an afterthought, little forethought is given to orientation, partly through sites that are not appropriate, but mostly through a lack of recognition of the basic needs of good orientation. Some designers are ignorant that good planning cannot be obtained without orienting with relation to the sun, the wind, and other natural elements, ignorant that no amount of interior design, planning, and thought can be com-

pletely successful if these elements are ignored or not successfully used, for interior functions are directly related to orientation, are enhanced by it, and are made more desirable by it.

Rules and formulas for proper orientation are of limited use, as the final decision will be a compromise between orientation and other important functions. Sunlight and prevailing winds will be important factors, but orientation will also depend on geographical considerations, climate, the site under consideration, the views, the existing landscaping, and the basic functions of the structure itself.

Of primary consideration in orientation is the amount of sunlight allowed into an area. The provision for sunlight onto a site contributes to better health, provides light and creates heat. The question then is not the possibility of sunlight but rather how much and into what areas.

The earth travels in an elliptical path around the sun and its angle with the earth is dependent on the season and time of day. The inclination of the sun's rays varies in the northern hemisphere from  $75^{\circ}$  at its zenith at 12 noon, June 22nd to  $29^{\circ}$  at 12 noon, December 22nd, and naturally from  $0^{\circ}$  at sunrise to  $0^{\circ}$  at sunset. The azimuth changes from its summer solstice of  $59^{\circ}$  E of N to its winter solstice  $56^{\circ}$  E of S for  $97^{\circ}$  W Longitude

and 38° N. Latitude (Plate III). With these factors, the problem is readily reduced to a decision of which area is best served with sunlight and how much shall be admitted at what seasons.

The amount of radiation received by a certain site is determined by several factors. Among them are:

1. Position of sun according to the time of day.
2. Position of sun according to the season.
3. Clouds and other obstructions.
4. Direction of slope of station.
5. Angle of slope of station.
6. Height of station.
7. Situation with regard to surroundings.  
(Aronin, 1), p. 28. (Plate IV)

"The amount of heat which a slope receives is made up of direct insolation and diffuse sky radiation. Direct insolation varies with the angle of the slope only." (Aronin, 1), p. 57. Therefore diffuse radiation as a heat factor will effect a ten degree north slope the same as a ten degree south slope. For direct insolation the ten degree south slope, being more closely perpendicular to the sun's rays will receive more B T U/hr. than will a ten degree north slope which is more closely parallel to the sun's rays (Plate V, Fig. 1). This leads to a greater difference of exposure on clear days than on cloudy days, since clear days allow for direct insolation while cloudy and overcast days allow for diffuse radiation only. Of course, this is relative to the latitudes, since azimuth, altitude, and declination affect the considerations to be given to the effects of direct

insolation and diffuse radiation. In the tropics, differences due to slopes are negligible, since at mid-day the sun is directly overhead and all directions of equal slope are receiving the same amounts of direct insolation. At the poles the differences due to slopes are also negligible since here one has a greater amount of diffuse radiation. It is only in the temperate zones (United States) that we should give architectural consideration to the effects of B T U gain through direct insolation and diffuse radiation.

From the amounts of radiation for vertical walls we find that in midsummer the east side of a house is most favored. Compared with a horizontal surface, an east or west wall receives less heat throughout the whole year, while a south wall, from September through March, receives more. The highest totals of radiation falling on vertical walls occurs in early spring and late autumn on a south wall. (Aronin, 1), p. 57.

It has been noted that although a thirty degree east slope receives more radiation than a west slope, the morning atmosphere being clearer, ground temperatures are lower in the east because of its shielding effect of moisture. The intensity of the sun on a horizontal surface is greatest at noon, regardless of the latitude, because at that time the rays have a shorter distance to pass through the earth's atmosphere as they are perpendicular or nearly perpendicular to the horizontal surface.

Altitude also affects the amount of radiation. The higher the altitude, the more solar radiation received. High up in

snow covered mountains skiers can keep comfortably warm on any sunny day. This writer has experienced this effect in the mountains around Spokane, Washington. The radiation is so great that parkas, sweaters and other such clothes are discarded in an effort to cool off. Shirt sleeves are sufficient. The insolation received varies because of the presence of snow, and the different reflective qualities of the surrounding surfaces.

The admittance of sunlight into a building or building parts may be desirable or may be a nuisance. This decision for each individual building is up to the architect.

The amounts of radiation received during a day are results of the time of day and the time of year, both of which are functions of the earth's rotation and inclination. During the day as the sun apparently climbs higher and higher (it is here assured that the earth is stationary), the amount of radiation received increases until the sun reaches its highest position. At noon the maximum amount of radiation is being received for that day and this gradually decreases as the sun begins its descent. Thus it is possible from charts and sun angle calculators to determine the sun's altitude and azimuth and determine where this radiation will fall or when an area should be protected. In all cases, it is at noon that the greatest amount of radiation is present.



Direct sunlight is the easiest to control by artificial means. This is most commonly done with overhangs, shades, horizontal and vertical louvers, screens, trees, and other means. All of these devices prevent the sunlight from entering an area. By adjusting the width of the overhang, angle of shades and louvers, location of screens and trees, one can keep the sunrays out of an area part of a season and admit it another part, thus making it possible to bar summer sun and admit winter sun. As well as adding enjoyment to the area, shade devices help reduce the cost of summer cooling by preventing the sun from entering and reduce the cost of winter heating by admitting the winter warmth. Interior areas with roofs can easily be controlled, but exterior areas present a more difficult problem. Here one usually cannot keep out the high overhead noon sun and can only try to exclude the late afternoon and early evening sun by use of screening devices.

Glare is caused by the refraction of the sun's rays in the upper atmosphere and reflected toward the earth. It is present in all directions, but it is from the north (in the northern hemisphere) that glare becomes a major problem. The exclusion of glare means to a certain extent the exclusion of some light rays, although the compromise here is definitely a benefit. Inasmuch as glare is a sky-cast light, the natural means to

prevent this is with wide overhangs that adequately protect the glass areas. A prime example of uncontrolled glare is present in two buildings on the Wichita University Campus. Glass block was used for a wall material in Neff Hall, constructed in 1950. The interior glare was so great that it was white washed and later covered with screens. The offices of the Department of Mathematics, in the Mathematics and Physics Building constructed in 1958, where the windows are painted with "Bon Ami" to reduce the glare, is another example. Both of these cases clearly illustrate the importance of controlling and reducing glare. The presence of trees and landscaping elements and wide adequate overhangs will generally control the glare.

Reflection is caused when light strikes an object and is repelled in another direction. Of this it is known that the angle of incidence will equal the angle of reflection. The unknown here is what will do the reflecting. It could be passing cars, a lake, or windows in the adjacent building. Reflections are seldom a serious problem, only an annoying one, and except for the presence of large bodies of water or large masses of glass areas deserve only minor consideration in orientation.

It is a necessity in building group design for the architect to concern himself with the results and effects of the orientation of his building group. He must pre-determine the

effect of the mass on adjoining structures and on the surrounding open spaces. Le Corbusier remarked that "The materials of town planning are: the sun, the space, the vegetation, steel and concrete, in that precise order and subordination." (Aronin, 1), p. 106.

Inasmuch as schools function primarily during the winter months, (although it is believed this will change to twelve months) these should be our first concern in preference to the summer months. At the summer months the azimuth of the sun and the altitudes are greater.

Plate V, Fig. 2 is based on a simple rectangular plan in which the winter sweep is  $112^{\circ}$ . Here the axes have been orientated parallel with the direction of the sun's rays at sunrise and sunset, and will assure that the ground around the buildings will receive sunshine at some time of the day all year around. This placement will vary with the latitude, and as such the orientation at Wichita University should be either south  $56^{\circ}$  east to south  $56^{\circ}$  west or, north  $56^{\circ}$  east to north  $56^{\circ}$  west, which is figured for the winter solstice. The farther one proceeds toward the equator, the more east-west the buildings can be oriented in order to take advantage of this winter sweep of the sun. However, as one approaches the equator, the problem may be reversed, and it may become desirable to create the greatest shadow rather than to eliminate it.

The shape and extent of the winter shadow is determined by the azimuth and altitude of the sun. If a building is of considerable height in comparison to its width (that is, a multi-storied building of considerable height, probably not to be found on a campus), then the winter shadowed area will take the shape of a triangle, the angles being established by the azimuth (Plate VI, Fig. 1). If the proportions change so that we have a horizontal rather than a vertical building, the shadow shape will be a truncated triangle because the sun's rays (as low as  $15^{\circ}$ ) come over the top of the building (Plate VI, Fig. 2). It becomes apparent that as the building proportions are altered from basically horizontal to basically vertical, the area of the winter shadow is reduced. If the aim is to keep the permanent winter shadowing small then the major axis of general rectangular buildings should not be more east or west than the sun's rays at sunrise and sunset, that is, in a general direction of north-east and south-west or north-west and south-east. Towards the east-west orientations the northerly facade becomes such that winter shadowing is developed to a maximum (Plate VI, Fig. 3).

Buildings of more complicated plan types may be considered as variations of a rectangle. Rectangles may be put together in such a manner as to form the L, the T, the U, the H and the curciform. The L, the T and the U (Plate VII, Fig. 1) are best

oriented in a south-east and north-west or north-east and south-west direction so that they cause no winter shadow. The curciform and the H, (Plate VII, Fig. 2) are not so easily oriented. Any arrangement which involves a recess on the northerly face will result in shadowing, and if the recess is deep enough, this will be an area of permanent shadow.

The British Ministry of Works reports that:

1. It has been observed that the dominantly horizontal types of buildings cast more extensive winter shadows than do taller, more slender units, and it is to be expected. Therefore, that where buildings of this type are grouped together, their shadows will affect one another. The development is representative in general type and density of that which is found in our urban districts, except that the street proportions are rather more favorable than usual to sunlighting. It will be seen that the shole of the ground area between buildings is shadowed and also, most of the lower stories of the buildings, except at street junctions, where the sky-line is broken. Upper rooms are generally insolated.

2. If the hollow square units are replaced by ones which are characteristically taller and more slender, the sunlighting is altogether altered. The 'permanent' winter shadows are small, and the transients narrow, so that shafts of sunshine break between the buildings and move across the ground. The stories of neighboring buildings then receive a sweep of sunlight, even if only for a limited period. The units have the same total bulk or floor space index as before and the same spacing center to center, yet it will be seen that much of the ground between them is sunlighted, and even the most obstructed buildings in the group are in sunshine at the lowest stories.

It might also be recalled here that with buildings at right angles there are narrow limits to the suitable orientation and, if it is necessary to deviate from these, the sunlighting would need more careful consideration. It would probably be useful then to make the units lying at one angle lower than those at the other.

3. In consideration of these factors we have come to the conclusion that as for daylighting, so also for sun-lighting where high densities prevail, the development with the vertical characteristics and adequate spacing of units has advantages which the horizontal development does not possess, and we therefore recommend that they be taken into account as factors in site development and town planning.

The total pattern of shadows tends to close up or clog when the shadows from individual units overlap. The clogging need not occur seriously, however, if the number of units is limited, it follows, then, that for a high overall density, local concentrations of accommodation would often give better results than distribution in many separate units. (Aronin, 1), p. 111.

Aluminum City Terrace by Gropuis and Breuer is a site planned irregularly according to the sun and with complete disregard for formula or geometrical pattern. It is laid out so that each building unit will realize the maximum sun orientation as well as other orientation features.

In building placement, consideration should be given to temperature differences due to the soils or materials surrounding the buildings. Orientation must be considered a design element, and if it is to be effectively used, temperatures of the area must be studied. Heating and cooling loads can be drastically changed and affected by the building's orientation.

It is also useful to know the probable maximum length of heat and cold waves within the area, and for proper landscaping, the first and last dates of killing frosts in the area. In the Wichita area the average date for the first killing frost in the fall is October 20th, and the average date for the

last killing frost in the spring is April 15th. The average depth for frost penetration is about twelve inches.

Facts concerning temperature changes and other phenomena are stated here as obtained from various texts, bulletins, and publications. It is well known that higher altitudes are usually colder than lower ones. According to Hare and Brooks the decrease in temperature is about three degrees F. for each thousand feet increase in altitude along mountain sides. While more fuel may be assumed to be needed, it must be remembered that the amount of solar radiation received during the day time is greater.

Small scale deviation in the climate can play a major role in selecting sites. Proper siting as opposed to haphazard planning may mean a difference of temperature equivalent to a change of several hundred miles north or south in the site.

The freeze-thaw cycle can be a very important consideration when the building is designed. This cycle produces the most extreme damage to natural materials. The roofs which are exposed to southern exposures will, even on days when the temperatures hover at freezing, warm up sufficiently to melt any existing snow or ice. However, this will probably be only a temporary condition, for as the sun sets and temperatures drop, the melting ice would freeze again. The roof should be steep

enough to allow the excess water to run off, yet shallow enough to retain an insulating blanket of snow. A slope of twenty degrees to twenty-five degrees is needed with the low point on the north side.

It is obvious to most as a result of personal experience that on a summer day it is usually much warmer when one walks along the street than through a park. The magnitude of this difference is usually not realized and obviously not considered in the attempt to provide acres of paving surrounding buildings to accommodate the multitude of cars. Temperatures of 120° F. are not uncommon for the surface of asphalt in the summer.

Plate VIII shows how asphalt stores up tremendous heat.

(Aronin, 1), p. 143. Its path of temperature follows very closely that of the sun except that it is still giving off a lot of radiation after the sun has set and continues to do so for several hours. Tables 1 and 2 show temperatures of different materials under the same sun exposure. (Aronin, 1), p. 145.

Table 1. Material temperatures.

---

Air temperature taken under standard meteorological conditions	77° F.
Concrete walk in the sun	95° F.
Dark slate roof in the sun	110° F.
Short grass in the sun	88° F.
Leaves of oak tree	81° F.
Soil in the shade of big oak tree	79° F.



Table 2. Surface temperatures.

Grass in sun	89° F.
Asphalt in sun	106° F.
Concrete in sun	111° F.

Plate IX, Fig. 1 shows the fallacy of locating buildings adjacent to streets and paved parking areas. Here is a seven-teen degree differential within fifteen or twenty feet, and it is radiating this heat right into our air-conditioned buildings.

In selection of the site, consideration must be given to the natural movements of the nocturnal air. As related by Geiger,

On the plateau, sections of which are shown to the right and left, along the valley walls and on its floor, the lower air cools off at night at the same time as the ground surface. If the air behaved like water, there would have to be a circulation like that at the upper left...and the temperature distribution would be arranged in horizontal layers according to the density as shown in the upper right. Such a simple circulation does not develop, however. On the contrary, a series of smaller circulations form on the slopes. In these, the cold air on the slope is mixed with the neighboring warm air, of which there is a great reservoir between the valley walls, as shown at the lower left. On the floor of the valley cold air accumulates. The cold lake which is formed there is deepened by the adjacent circulation on the slope. The intermediate condition depicted on the slopes reaches even to the edges of the plateau. The resultant temperature distribution is shown at the lower right . . . The x plateau is cold and the valley floor, very cold, but the higher part of the side slopes are warm. We speak therefore of a warm slope (thermal belt). It is the safest place in areas and at times where there is a danger of frost. It is often indicated by the vegetation. (Plate IX, Fig. 2 and 3) (Aronin, 1), p. 157.

In campus planning one should use the following methods to help relieve the excessively hot temperatures:

1. Supply an abundance of green areas, pools, lakes, etc.
2. Place buildings so that they shade each other.
3. Provide for narrow streets that are well landscaped to prevent the sun from entering and allow for ventilation.

To retain the warmth the following are suggested:

1. Use massive, heat-retaining materials wherever possible.
2. Utilize heat from artificial and natural sources.
3. Snuggle the buildings against one another. (See spatial concepts.)
4. Prevent heat from escaping into exterior areas or undefined spaces.

Colors as heat absorbers and reflectors should be given due consideration by the planners, architects and decorators. Of course, the allied heat conductivity characteristics of materials must be considered along with their colors.

Generally white or light surfaces tend to reflect heat while black or dark surfaces tend to absorb thermal radiation. Roof and walls of tropical homes are usually white and so is the attire worn by these people. Table 3 shows heat absorption percentages of various colors. (Aronin, 1), p. 163.

Table 3. Relative effects of colored surfaces on temperatures in percent.

Black (assumed as)	100%
Dark blue, brown, green	85-90%
Grey, cement wash, ash, plain metal	75-85%
Khaki, red, light brown, pale blue, aluminum paint	70-75%
Pale colors (straw, cream)	50-55%
White	40-50%

The interest in wind for orientation purposes is with its direction and velocity. Advantages to be achieved from the wind are:

1. The wind is a source of ventilation.
2. It evaporates (a cooling process) moisture and dries surfaces.
3. It cools.
4. It warms, by preventing cold air from sinking at night.

Its disadvantages are:

1. It spreads smoke and odors.
2. It has destructive powers.
3. It cools.
4. It assists in drifting snow and drives moisture.

Advantages and disadvantages must be considered in planning with regard to local and regional winds: frequency of wind by direction for the months, average wind speeds by direction for various months, number of days with strong winds and days with little wind. Deductions for planning purposes may be obtained from this data. Decisions can be made with regard to building locations and directions of major and minor axes.

Local winds are calmer at night and stronger during the daytime heating periods. Different cooling coefficient of adjacent surfaces will produce local winds at night such as on the shore of a large lake or in mountain areas. In the summer during the heating hours the earth heats faster than the water, and so cool air from the lake flows in to replace the uplifted

air over the earth. At night the air over the land cools, the temperature above the water is warmer, and the reverse takes place. A similar condition exists between urban and rural places.

Nocturnal winds in valleys tend to flow down as the higher, cooler air tends to replace the expanding warmer valley air (Plate X, Fig. 1). Again there is a situation of temperature differences similar to water and land, which probably will reverse itself during the heating daytime hours.

Wind velocities are slowed down by the ground. Brooks states that,

The average wind velocity increases with height above the ground. The rate of increase depends on the nature of the surface, being least above water surfaces or smooth grass lands, and greatest above broken irregular ground or surfaces broken up by buildings. It is also greatest at night and in cold weather, and least on hot sunny afternoons. (Aronin, 1), p. 186.

Le Corbusier has probably accomplished more than one purpose with his roof gardens. Consideration should be given here to the design of low horizontal versus tall vertical dormitories and campus buildings occupied at night.

On campuses which have an abundance of trees, careful considerations should be paid to the removal of some of these trees for a building site. In a clearing strong eddies may be created depending, of course, on the size of the surrounding

forest and the size of the clearing. Plate X, Fig. 2 illustrates this. However, there is an advantage of building on the windward side adjacent to the stand of forest (Plate X, Fig. 3), as the prevailing winds will tend to lift over the building; but building on the leeward side (Plate X, Fig. 4), will offer less protection because of severe eddies which are often created on the leeward side; however, some protection may be afforded as these eddies are a function of wind velocity, tree heights and building size. This is not saying that windbreaks are not efficient. C.E.P. Brooks states that "four zones may be distinguished in wind velocity on either side of a windbreak (Plate XI), and that ratios appear to be constant, irrespective of the height of the windbreak and the strength of the wind." (Aronin, 1), p. 190. Thus a belt of trees fifty feet high protects five times as large an area as a hedge ten feet high. In more rural than urban campus locations, windbreaks, as well as being aesthetically pleasant and architecturally desirable, afford a winter protection by reducing wind velocity, reduce soil blowing and snow drifting, reduce fuel bills, and protect students during class changes.

Similar wind effects take place rising over a knoll or small hill as in rising over a forest.

Exactly how the winds react over a campus must be studied on that particular campus. We know that there are many factors which will influence these winds: mountains and valleys, land and water, urban or rural, the terrain and the topography.

Precipitation consists of rain, snow, hail, sleet and fog, all of which introduce moisture into orientation.

Precipitation data for the Wichita, Kansas, area has been taken from maps and charts of the United States Weather Bureau, and a selected few are given here.

Average annual precipitation - 36 inches.

Average warm season precipitation (April to September, inclusive) - 25 inches.

Average winter precipitation (December to February) - 4 inches.

Average spring precipitation (March to May) - 10 inches

Average summer precipitation (June to August) - 12 inches.

Average number of days with precipitation of 0.01 inches or more - 80.

Maximum precipitation in one hour - 3 inches.

Maximum precipitation in 24 hours - 6 inches.

Average annual snowfall - 15 inches.

Average annual number of days with snow cover of 1 inch or more - 30.

Advantages of precipitation can be outlined briefly as:

1. Insulating quality of snow.
2. Moisture as a cooling agent.
3. Psychological and aesthetic effects.
4. Reflection of beneficial radiation.

Disadvantages may be stated as:

1. Drifting of snow.
2. Damage of dampness and annoyances.
3. Flooding.
4. Dangers of sleet and fog.
5. Danger from hail.

Mountains are conducive to the production of precipitation. The windward sides are normally the wettest, the leeward sides normally the driest, and generally precipitation increases with altitude. The highest speeds of the flow of wind occur on the windward side of a hill and the distribution of precipitation is partly controlled by this action. As a complete reverse of mountains, over flat topography and low hills wherever the wind velocity is greatest there is a relatively light precipitation. Therefore, with building siting the windward side will be the driest and the leeward side may cause added consideration in the removal of the moisture from around the building. One of the greatest dangers to hillside locations is not the rainfall but the erosion caused by the flow of surface water.

The placing of windbreaks as previously discussed must be considered with reference to snow. Snow fences are placed to protect an adjacent area from drifting, and this drifting takes place at the snow fence on the leeward side. The principal involved is that the open fence hinders the forward thrust of air, and in the resulting area of relative calm (the leeward side), drifting snow will result. If the foliage of the windbreak is dense, the snow will probably collect on the windward side; otherwise it will be deposited on the lee side. Particular attention must be paid to landscaping locations to insure that

drifts do not occur across drives, walks, and around building entrances. Snow with a high moisture content and driven with strong winds has a tendency to cling to the windward side of obstacles, but this is due to both the strong wind and wetness of the snow.

Orientation with regard to precipitation should be based on the slope of the site, the direction of the prevailing wind, and the sun. Caution must be exercised that the slope of the site is sufficient to drain off water, is not so steep as to cause erosion, and is not adjacent to a site that would tend to feed its water to this area. The choice of the site may mean additional expenses and design considerations to control or dam this surface water such as the earth-dam protecting the Engineering Building and Neff Hall on the Wichita University campus. The wind and sun are mentioned as means of natural evaporation. Either or both will have some influence on the site during the day.

The removal of rain from a campus can pose several engineering and architectural problems. The greatest danger lies in cloudbursts. It is important to know from which direction thunderstorms usually come and which direction the water is shed. Drainage systems should be placed perpendicular to this direction. Parallel with the direction of the storm will allow



the first leaders to become full and incapable of receiving water as fast as it could be transmitted through the system, causing flooding of the area. Perpendicular drainage allows more leaders accessible to the sudden onrush of water. In no case should a university be allowed to discharge the large amounts of water from even a normal rain into the streets of adjacent property, as is done with twenty-one acres of parking at Wichita University. This indicates deficiency in the planning and engineering stages and complete disregard by the university for private and public property. Green areas on a campus help relieve this problem, but as the campus surfaces become more and more space for parking, the problems will become more acute and require adequate engineering to reach a solution.

View and vista are concerned with orienting the buildings and locating the interior and exterior areas so that a visual and possibly physical correlation is established between these areas and the natural topographical elements. This means situating the buildings to take full advantages of the visual beauty of lakes, rivers, streams, hills, mountains and valleys, or on a simpler scale, the trees, bushes, gardens and other developed areas. This is the extension of the interior, interplay of interior and exterior spaces, the bringing of the exterior into the interior, the extension of space.

Orientation for natural lighting will vary with the function of the building. Some building uses require the admission of sunlight while in others direct sunlight must be prevented. In residential units sunlight should be admitted into most areas. Sunshine should be available in the kitchen in the morning, especially in winter, and there should be some sunshine in the living room in the afternoon.

North light is generally recommended for classrooms, although elementary and intermediate grades can benefit from a more enjoyable atmosphere created by a play with sunshine. Under no circumstances, however, should direct sunlight enter a room in such a way as to cause glare on the floor, desks or chalk-boards. In laboratory and drafting classes where an even uniform light is desired, north orientation is best. North light is the most even throughout the day. There is no evidence of sun movement caused by shadows and variations of light intensity due to clouds passing between the observer and the sun.

In the campus hospital sunlight should be admitted into every room. Sunlight is necessary for proper vision, psychological effect, and protection from cross-infection.

In general, where bright light is preferred, orientation to the south is desirable. The south-east quarter will receive

the morning sun and the south-west the afternoon and evening sun. Room function will dictate this orientation. East and west orientations have properties which are similar to those of north and south according to what hour of the day they are used. Thus, orientations to the north may be extended to the east if employed only in the afternoon or evening.

Building shapes and the arrangement of building groups are a function of environment and should assume shapes compatible with their climatic location. A report on environment and building shapes in the U.S. divides the country into four climate zones; 1) cold zone; 2) temperate zone; 3) hot-arid zone; 4) hot-humid zone. (34), p. 105. A study of plant life in these four zones shows how they adapted their shapes to withstand the extremes of these zones. In the cool zone forms are compact and pine needles are slightly flattened cylinders to withstand the unfavorable conditions. In the less severe temperate zone the friendly environment encourages the plant leaves to open to a considerable size. Forms are massive for protection in the hot-arid zone. The strenuous climate causes plants to be bulky and the leaf surfaces to be reduced. The hot-humid zone finds leaves that grow roughly two and one-half times as large as those in the temperate zone because of the wet, warm hothouse climate.

With this as a basis, architects Victor and Aladar Olgyay at Princeton University's architectural laboratory used one city in each of the four zones (Minneapolis, Minnesota; New York City, New York; Phoenix, Arizona; Miami, Florida) to study various plan shapes to determine which shapes are most favorable thermally. (34), p. 106. They found optimum shapes for each locality by determining those shapes that lost the fewest outgoing B.T.U. amounts in the winter and received the fewest incoming B.T.U. amounts in the summer. The building assumed covers ten thousand square feet, is one story high and has insulated frame construction, forty per cent glass on the south wall and twenty per cent glass on the other walls. Plates XII, XIII, XIV and XV shows the results of the B.T.U. gains and losses. This figure indicates that: 1) all the shapes elongated on the north-south axis work both in winter and summer with less efficiency than the square one; 2) the square building is not the optimum form in any region; 3) the optimum lies in every case in a more elongated form somewhere along the east-west direction. Their research indicates further that substantial savings can be made in heating and cooling costs because of the building shapes as shown in the following table: (34), p. 107.

Table 4. Heating and cooling costs.

Zone	City	% Cheaper to heat	% Cheaper to cool	Ratio
Cold zone	Minneapolis	1.4	1.6	1:1.3
Temperate zone	New York	4.6	4.2	1:2.4
Hot-arid zone	Phoenix	26.7	2.5	1:1.6
Hot-humid zone	Miami	16.3	8.1	1:3

As buildings grow upward, the volume effect changes the scale of climatic impacts. The cause is the obvious geometric law that the growth in a linear direction is on the first power, in a surface on the second power, and in volume on the third power. This means that the same form enlarged four times will scale down its proportionate surface and hence the environmental impact to one-fourth. (34), p. 107.

Concluding from this research, campus buildings could take advantage of their grouping and shape to make more effective use of the climatic locations. In the cool zone close compact forms are preferable because of their relatively dense cubature. Elongated unilateral buildings are not favorable. The environmental conditions suggest higher buildings. The layout should provide for shelter against the winds. Larger building units should be grouped closely but spaced to utilize beneficial solar insolation in an isolated, dense layout (Plate XVI). In the temperate zone (Kansas) there is the least stress from any specific direction; therefore, this environment allows considerable freedom in form. However, forms on the east-west axis are preferable. Plans can be open and the buildings can merge

with nature through a freer arrangement (Plate XVII). In the hot-arid zone massive shapes are advantageous. Cubical or slightly elongated forms toward the east-west axis are most adaptable. High buildings are preferable. The layout should protect against the heat with dense shaded areas (Plate XVIII). In the hot-humid zone elongated buildings in the east-west direction are the best. North-south buildings are least desirable in this zone. The buildings should be separated to utilize air movements. Shade trees should be abundant. The general layout should be loose and scattered (Plate XIX).

#### Vehicular Traffic and Parking

The problems created with the admission of cars and car traffic to the campus is one of the most critical and burdensome subjects with which the universities are faced. The rapid acceptance of the motor vehicle as a social necessity has been an innovation to our entire society. It has changed the size and shape of the cities, caused the criss-crossing of the country with roads and highways, redesigned homes, and has had as large an impact on daily lives as any of man's many inventions. Like it or not, it must be admitted that the car is here to stay, and its shiny, "chromated", industrial appearance is now and will continue to be a part of the campus scene. The problem

becomes one of coping with the car, not ignoring it; of finding an adequate solution and assigning the car to its sub-ordinate position as a campus convenience, not a campus necessity. A general statement as to whether cars should be allowed or barred from the campus cannot be made. As with many other campus problems, this becomes one of local nature and must be decided with a specific campus in mind. In an urban university the problem and considerations are different from those of a rural university. A private school will view the problem differently from a public school. A technical institute may use values in judgment different from those of a liberal arts college. Each school with its basic philosophy will view the problem in a different light and with a different sense of values. In no case, however, should the car and its required facilities be allowed to dominate the physical, the social or the economical considerations of the campus. As major a necessity as it has become, it must still be sub-ordinated to the intellectual development of the university and to the physical plant which supplements this development and provides the atmosphere in which learning is obtained. In all considerations the purposes of the college must be maintained, and the conveniences, whether stationary or mobile, must be delegated to a lesser position. Student housing facilities and public transportation are the

two major considerations in evaluating the necessity of campus traffic and parking facilities. In situations where adequate housing is available on campus, be it dormitory or fraternity housing, the provision for student car traffic and parking should be held to a minimum. Provisions must be made of course in all cases where there is evidence of hardship and where the student is physically required to have transportation. If distances permit (a man can walk at the rate of 250 feet per minute), students should not only be discouraged, but prohibited from driving to and from classes. Allowing students to drive from class to class creates traffic problems, both car and pedestrian, and will necessitate the spotting of parking areas and drives in undesirable locations. Where distances become too great, parking should be provided, but on an area basis and not an individual building basis. Periphery parking and area parking will solve these distance problems.

In cases where on campus housing is not adequate, or is a problem particularly noticeable amongst married students and in urban schools, periphery and area parking offers the only solution to adequate control of campus car traffic. Allowing these cars on the campus not only creates this traffic problem, but the directing of cars into and out of the area and periphery parking must recognize the areas through which these cars



must pass. Direct diverting of campus traffic problems into adjacent areas, whether they be residential or commercial, does not solve the problem. The university must recognize its obligation to the adjacent properties and not simply dump its problems into these areas. The periphery parking should have adequate ingress and egress for maximum loads at (various) hours. Exits onto arterial highways and major thoroughfares should be avoided. These parking areas should be placed so as to offer the least resistance to the normal flow of traffic. If need be, secondary roads should be constructed to serve as private parking access or as feeder lanes for this periphery parking.

Area parking must consider three major points: access to the area, academic uses, and public uses. These three points must be fully considered before any final decisions are made. Access should be convenient, should consider other functions and uses for the access road, and should be aesthetically desirable. The convenience must be measured not only in regards to the parking area but to other buildings and areas which it might serve. Consideration should be given to student flow and patterns so as to offer the least hinderance to students as they change buildings. These access roads should not wander aimlessly through the campus, destroying spatial relationships and separating groups, but rather should complement and offer

definition to the areas. Roads can destroy spatial unity. They themselves do not necessarily cause the separation in space, but their use as traffic ways does cause this separation. Roads as horizontal planes do not destroy space; their use by vehicles does. Convenience also includes the topography, construction costs and maintenance costs. Whether to use relatively flat parking areas and roads or to use curving streets that follows the natural terrain will affect the convenience of the access. Weather conditions such as seasons of heavy rain, sleet and snow will determine the practicability of various solutions. Initial versus maintenance cost is a specific problem that will have to be dealt with at each individual location. However, budget-conscious administrators are admonished not to be penny wise and dollar foolish. Black top may be initially cheaper, but without an adequate study of the base or soil, the maintenance costs may soon devour any initial savings. These access roads should serve as design elements, and their location must be judged in relation to the area they serve and how they serve it.

Academic locations should be determined by considering the needs of the group to be served and the relationship between the group and the parking area. Random placing of parking lots in open areas without consideration of the space they occupy

is one of the poorest means to locate these areas. Academic functions and groupings should be studied as to needs and actual relations between the group of buildings and the parking spaces. As a supplement to periphery parking, group parking lots should serve to reduce the walking time between the parking area and building groups, the planner considering not only minimum distance but a reasonable time element. It is felt that not every group needs its own parking, but rather a few strategically located areas which can feed students into the academic groups. This, again, is a specific problem and no definite area or location can be given. The plan must take into account the buildings or groups it will serve.

Public parking, as opposed to academic parking, refers to areas whose size and locations are determined by the use of the general public in attending university functions and taking care of university business. This may vary in size from a few private parking spaces for the president's guests to acres of parking for an athletic event. This parking is determined by the location of buildings that have public functions such as administration, the stadium, the auditorium, and the student union. For these locations there should be sufficient (however limited) easily accessible, well defined, adjacent parking areas. These areas can either be combined with general area

and periphery parking, be separate areas with general parking when not used for public assembly, or private restricted areas. The most suitable arrangement in most cases is a compromise between combination public and student parking and a few restricted areas. For instance, the parking adjacent to the president's office, the general administration and the registrar's office should be restricted to university guests and parents and not open to students, faculty, or service people. Those areas adjacent to the auditorium, the athletic fields, and the student union can be reserved for student parking during normal operations and open to the public during the times when they would be attending such events. Land area is too valuable to allocate too many parking conveniences, and multi-functional areas are the only logical answers.

Except in the cases of hardship and extreme distances, the university should not provide for the parking of the entire resident student body. Adequate parking for public facilities, group parking for general locations, and periphery parking are sufficient. Periphery parking should be utilized to the utmost with a minimum of group parking areas. Not only does periphery parking allow for convenience in location to a specific area on the campus, but it serves in a limited extent as a buffer zone between on-campus and off-campus areas. As a

ring (and it need not be continuous) around the campus it allows for easy pedestrian access to specific areas and consumes a minimum of area in any one location.

At this writing it is believed that no school has given serious thought to multi-story parking areas. In those areas, particularly urban, where land area is at a premium or non-existent, multi-story parking garages will offer a possible solution to parking problems. Such structures (ignoring initial costs) in a downtown area could conceivably serve as both student parking during normal school hours and public parking during after hours. However, under these conditions, there is no actual "campus" involved, as this type of building group is on a more or less commercial basis and does not present a spatial consideration except in the realm of city planning. The problems of this mid-city campus become problems in city planning and are not within the scope of this thesis. Construction of parking garages on rural campuses at this time seems highly improbable. All physical plants are in need of additional classroom buildings and cannot afford expensive luxuries as parking garages. All parking should be removed from the campus and parking prohibited before serious consideration be given to this type of structure. Parking garages or ramps might be considered for areas frequently used by the public (fieldhouse,

stadium, or auditorium), but not for resident student areas. It may, in time, become necessary to consider parking garages, but it is believed that adequate public transportation and shuttle services should be investigated before deciding on a parking garage.

Campus drives and streets should be provided for access to each building but not as a public thoroughfare. As a general rule it can be stated that the fewer the streets the better the campus. Drives that provide straight direct crossing of the campus tend to divide the campus into small, non-related areas. Drives should be maintained to parking areas and to service areas, but scenic drives have no place and no function on the campus. Streets and drives criss-crossing the campus provide short-cuts, speedways and pedestrian traffic barriers. Periphery drives with feeder lanes into a few selected parking areas and building groups are adequate, and there is no need for a multitude of random streets, drives, and lanes.

Fire access to all buildings can be provided by constructing sufficiently wide reinforced concrete walks that will serve a dual purpose, both as fire access and as service drives. The frequency of fire alarms does not necessitate curb and gutter type access to each and every building. Such a need can be adequately provided for with reinforced walks. Service calls

should be limited to before and after class hours so as to offer the least interference with classroom functions.

On a campus that has become surrounded with residential areas and has formed a minor block in street construction between those residential areas, a cross campus street to provide traffic flow into and out of these residential areas should be considered. This may tend to divide the campus into two areas; however, if the campus functions are so located and the relationships between those two areas so organized, then this division will become minor with respect to campus activities and a major convenience with respect to residential traffic. While it is true that sufficient zoning and regulating might have prevented this surrounding residential or commercial district, if it has already grown up then it becomes the responsibility of the college to help alleviate the new problems and provide some means of traffic flow in respect to these areas. It should be the college's role as the community leader to prevent or provide for such conditions, if not prevented, then provided for as a courtesy and obligation to the community. It is much better that the college recognize and provide for these conditions than to be forced at a later date to allow the community to say where and how these access roads are to be located.

## Pedestrian Circulation

Pedestrian flow and movement is the means by which students move from one building to another, one area to another and from one building group to another. It is interior and exterior, horizontal and vertical, and combinations of these. As opposed to vehicular traffic, pedestrian traffic should be provided for with sufficient, well-placed walks and areas, and should be protected. Exterior circulation (interior circulation is a specific building design problem and will not be considered here) of the student body must be observed as to peaks, volume, directions, and distance.

Traffic should be observed so as to determine the density of students at the end of various class periods. When students leave a building they should be easily and quickly disbursed away from the building, and into other buildings and groups. Landings and area ways immediately outside of buildings should be of sufficient size to receive the maximum number of students at any hour. Major walks should lead from group to group and minor walks serve the buildings within these groups. Rather than the random placing of walks or of laying walks over well worn student paths, major walks twelve to fifteen feet wide should be located between major buildings and building groups. These should not necessarily be the shortest and most direct,



but a compromise between functionally convenient and aesthetically pleasing. Criss-crossing the campus with a multitude of walks does not adequately serve the pedestrian flow. The fluctuating of classes, of department locations, of new building locations changes the traffic patterns and flows. Rather than a provision for all these fluctuating conditions which cannot be predicted or maintained, a better solution is to provide arterial walks between the main groups and feeder walks to various buildings from these. Pedestrians will follow these walks if they are reasonably direct and sufficiently attractive. To try and force the use of mis-placed walks with fences and signs is absurd. If the walks were aesthetically pleasing with landscaping, indentations, transitions and articulation, fences would not be needed. With the continual monotony of most existing walks, it is refreshing to walk on the lawn. And what harm does this do? To try and maintain constant uniform areas of greenery is in strong contrast to the facades surrounding this greenery. If the architecture was attractive the grass and walks would complement it, instead they contrast with it. Walks can become a design feature using many different materials and material combinations.

As a supplement to these fair weather walks there should be a sufficient number of well located canopies and covered

walks for inclement weather. To provide mechanical comfort and protection within a building and then not provide for some protection between them seems inconsistent. Students should be able to move over the greater portion of the campus with some protection from rain and wind. By using buildings (over the protests of the janitorial staff) and canopies between buildings it is possible to devise a system of interconnections which will provide this protection. Permanent canopies with removable sides afford protection from the sun, the rain and the winds. It is probably not feasible to connect all buildings and it is not advocated here, but there can most certainly be interconnections between closely related buildings. Such schools as fine arts and engineering, which may have several buildings, should definitely provide for access between them with ample protection.

### Building Groups

The physical arrangement of campus groupings can best be accomplished on a functional basis. An analysis of these functions shows four primary groups; academic, public, service and housing. These four primary groups can contain secondary functions in their relationships and service to each other, such as a primary academic function with secondary public service.

With only minor exceptions all campus building groups can be arranged according to their primary and secondary functions.

Academic groupings are composed of those buildings and structures whose primary purpose is to serve as student and faculty aids in teaching, learning, and research. This group contains classrooms, lecture halls, libraries, laboratories, research facilities and study areas. The specific use (business, fine arts, education, medicine, law or engineering), is incidental since the uses within these fields of study will be similar. These academic groupings should be secluded and well protected from exterior disturbances. Campus zoning should protect them from high noise levels, from vehicular traffic, testing laboratories, practice fields and other distracting activities. These areas should be well landscaped to form an intimate and informal group capable of inspiring all who enter and psychologically aiding teaching and learning.

At any large university there will necessarily be several academic groups. To try and provide but one would require too large an area, and its complexity would destroy the intimate and informal effect of a smaller grouping. The form and shape of a group should conform to design criteria based on function, orientation, and relation to other groups, and the buildings should be interconnected so as to afford protection during

class changes. The group's nearness to a central library is desirable. A radial plan which surrounds the main library with these academic groups would be an ideal arrangement. When a relationship to the library cannot be maintained, then academic groups should be designed with relation to each other.

Public groups are those groupings and arrangements which cater to the general public. These groups contain the administration, the athletic fields and fieldhouses, the auditorium, the extension service, the hospital and the chapel. It is to these areas that the public is most likely to go for concerts, lecture series, graduation and athletic events. Here we have multi-functioning areas that will be used by the student body with the public, or by the students alone or the public alone. These should be easily accessible from both the academic groups of the campus and the drives that feed onto the campus. Parking areas should be reasonably close to the buildings, and the drives to and from the parking should be well marked and adequate to handle large volumes for short periods.

These public buildings need not necessarily be arranged into an actual grouping, but can stand as masses in space, related to each other and to other groups on the campus. From a functional standpoint close proximity between the administration and other business offices is desirable, as is a close

arrangement between areas for intercollegiate sports. Such structures as the auditorium, the hospital and the chapel can be related by walks, landscaping, building shapes and other design elements to either these public groups or to academic groups or left as separate entities. Relationships here can be obtained by viewing the overall campus as a composition and locating the public buildings as a complement of this composition, mindful of zoning, access, orientation and function.

Service groups should, if at all possible, be a composite of all service-type buildings into one group containing the power plant, fire station, maintenance equipment and other such allied services. These should assume a remote location, removed from the general activities of the campus. They do not belong in the center of the campus. Regardless of any initial saving in heating and piping tunnels or convenience of fire lanes, they should be recognized for their function, and not be placed in a central or prominent position. If any single building or group should be assigned a central location, it should be the library, both as a convenience and as the symbolic center of the university. A university is composed of a faculty, a library and a physical plant, in that precise order. It is well to remember that the basic purpose of a university is to promote learning, not provide water and steam to various buildings.

Service buildings centrally located or scattered across the campus disrupt the continuity of the physical design and do not add to the functioning of the other groups.

Housing groups have increased in size within the last decade. Where formerly the campus had dormitories and fraternity and sorority houses, a third group for married students has been added, and now faculty housing should be considered. This large group can be divided into five smaller groups such as men's dormitories, women's dormitories, fraternity and sorority housing, married students' quarters and faculty housing. These five divisions should form their own individual groups on the periphery of the campus. Relationships between groups is not necessary except that they can share common parking areas and sport fields. Adequate playgrounds and parks should be located adjacent to faculty and married students' housing.

#### Building Arrangements

This thesis will now take some examples of building arrangements and with these examples attempt to show how spatial relationships were established. With the aid of a definition for space, it can, with the use of drawings and illustrations, show the relationship and proportion between solid and void. It must be remembered, however, that it is describing

on a two-dimensional plane (the pages of this thesis) what actually is in four dimensions, and that the true measure of architecture can only be obtained by experiencing its presence and being contained within it.

Space relations of a building, between buildings and between groups of buildings can be categorized for purposes of analysis. Generally one finds two types of composition and grouping under which could be listed many variations and combinations.

1. Space walls - Space defined by the assembling of architectural elements to enclose or partially enclose an area. Examples would be the use of such elements as facades and street frontage, optical barriers and enclosed volumes, squares and interrelated squares, groups formed to enclose and suggest enclosure, the focus of radial streets and axial vistas.
2. Mass in space - Space not defined as a measurable area but existing as a complement to a physical penetration of this space. Some examples would be a single or dominant element in space, groups of elements related or interrelated.

Among the multitude of arrangements of groups of buildings for establishing spatial definition, Plates XX, XXI and XXII occur most frequently in gridiron patterns. The allowing of vehicular traffic is probably the greatest cause for their failure as effective spatial volumes.

In this "grouping" (Plate XX) there is a loss of spatial enclosure through the open corners. Methods such as this were not used by ancient builders, who recognized this lack of enclosure. This is simply a superblock left as an open space in which the streets tend to separate the space walls from the floor.

Plate XXI is a slight improvement over the previous grouping. Here the loss of space is reduced by the vanishing of the perspective. The facades of the space wall are brought into relationship with each other instead of only the corners of the buildings.

The arrangement in Plate XXII occurs so often in ancient city squares that Sitte says it is one of the principles of ancient spatial enclosure. From the outside the visual appearance is of the enclosure since from any entrance the view is stopped by the facade of a building.

An arrangement similar to those shown in Plate XXII and Plate XXIII will establish a better enclosure than the previously shown "superblock". When seen from the outside you have the effect of mass and from the inside the feeling of containment. With the addition of a focal point the interior space becomes more definitely the feeling of an enclosed volume.



Plate XXIII is spatially unsatisfactory. It does not enclose or define space because the voids are at the natural focal points. The facades tend to lead the eye to the voids. From the outside one looks straight through the space as there is nothing to close or arrest the view.

The grouping in Plate XXIV is an improvement over Plate XXIII, although from two directions the view continues through the space. If an actual spatial enclosure is being established, the importance of closing the view is to give the effect of volume. From outside the grouping, mass is apparent, but to establish enclosure, volume must be suggested.

Visually Plate XXV is a completely enclosed space although bridged over at each corner. With use of a colonnade the separation usually caused by the streets passing between the walls of the space and the floor of the space is not apparent since the rhythm of the columns and the unbroken roof of the colonnade carry entirely around the area.

We have examined three groupings for organizing volume. Volume (and thus enclosure) is more strongly suggested where there is an unbroken change in planes of the space walls. Figure 3 (Plate XXV) illustrates this as it is a solid at the intersection of the planes. Conversely the weakness of Fig. 1 lies in the void at the intersection of the planes and relies

on an implied intersection rather than a visual one. The need of a focal point in Fig. 3 has been mentioned, and with this focal point it can, because of the solid at the change in planes, become a strong spatial enclosure. Fig. 1 even with additional architectural elements will not develop the feeling of spatial enclosure that can be obtained in Fig. 3, as it lacks the basic suggestion of volume. Figure 2 is an attempt to suggest a solid corner by the changing of the relationship between the planes of the space walls. In effect it lies between Fig. 1 and 3.

Shown in Plate XXVI is a totally enclosed space opened up at the ground level to give spatial expansion. There are roads outside the space onto which the building looks; but there is a fundamental difference between this and the strictly street facade in that here is an enclosed space with the horizontal extension and volume both into and out of the enclosed area. This composition is similar to the medieval cloister groupings in that the buildings are viewed from both inside and from outside space. Spatial extension of contemporary architecture is the result of this type of thinking.

When it is desired to give one particular building more emphasis than the others or to modulate a space, it may be projected into space, or alternatively be moved away from the space in such a way that it can be seen in three dimensions

and yet act as a space wall. This means using projections and recessions for better spatial definition (Plate XXVII, Fig. 1). The building in Plate XXVII, Fig. 2 reveals its three dimensional qualities as it extends into a spatial enclosure. It will tend to separate the space into two different areas.

If buildings in a group are of very different heights then it is almost impossible to establish a recognizable spatial volume without recourse to an optical device. The usual method is to establish common heights around the space by having horizontal architectural features. With the use of canopies with columns, the front edge will draw a line around the space and its soffit will establish a common horizontal plane and put a partial lid on the volume (Plate XXVIII). These columns and the edge of the canopy form an "optical wall" around the space and very exactly define this space to the height of the canopy, and above that lets it dissolve into a loose volume or dissolve completely. This gives visual enclosure yet freedom of horizontal and vertical space. Continuation of the canopy tends to enclose volume.

The common method of relating buildings by controlled view points is a Beaux Arts method of axial vistas (Plate XXIX, Fig. 1). In this system the buildings are designed in a symmetrical composition about a principal line, and they are

arranged to face each other in such a way that their center lines coincide to form an axis. It is important that the line of the axis runs through a clear open space, because the vista from building to building is the objective, not the imaginary axis. The axial system is typical 19th century civic grouping, and even though interest is usually added by establishing a secondary axis, it does not create excitement because it is composed about a few ideal viewpoints, little attempt being made to obtain a complex relationship in space. In Plate XXIX, Fig. 2 one building is shown at some distance from the other and to emphasize the ideal viewpoint, the path of the vista is enclosed by the avenue planting, the building thus becoming the focal point in a framed view. All the buildings may be separated so that they face each other down long avenues, each becoming a focal point or terminal feature in a long vista.

From the axial vista and termination of a vista evolved the use of streets for a more spatial and grand scale. New Delhi and Washington, D.C. are such examples. The more numerous the avenues which converge on the terminal feature, the more numerous are the vistas obtained. This leads to multi-focal radial planning. When many roads meet at a focal point, they join together to form a large space, which has the effect of isolating this space. If the road pattern is a symmetrical

one and each facade of the building designed as a focal point, the building becomes symmetrical. This is the ideal form of the Renaissance town, a dominant building designed as a perfect geometric figure set in the center of the geometric space which reflects its forms and from which the roads radiate out in star formation.

When buildings stand in space, the facades of each one of them meet at external angles, and there is an effect of mass (Plate XXX, Fig. 1). When the process is reversed and they are arranged around the space, the facades of adjacent buildings meet at an internal angle and there is the effect of volume (Plate XXX, Fig. 2). The greater the similarity between the facades of adjacent buildings, and the fewer the openings between them, the greater will be the sense of spatial enclosure, provided always that the relationship between height of buildings and width of space does not become so great that the walls of the space fall apart. The walls (of the buildings) themselves will react on each other, both in their overall pattern and proportion and in the way their horizontal lines come together at the internal angles, and they will influence, and be influenced by the proportion and pattern of the floor plane. When the walls around the space are ranged at about the same level, the cornice or eaves draw a line around the space.

Looking up at the buildings the eye tends to bridge the opening between the common eave line and we have the sense of a lid on the space. This space-ceiling gives us the feeling of an enclosed volume, like a room, and while it cannot be subject to the same exact definition of a room, it is essentially one that is measurable. We should think of it as a space body, the reverse of the plastic body of a building.

When buildings form the walls, to be complete spatial enclosure, the receding lines on either side of the observer, being cut off by the wall of the building in front of him, do not appear to vanish to a distant point, therefore, an irregular spatial layout is not objectionable (it is often pleasing) unless the angle is very acute or obtuse as the wall planes of the adjacent buildings tend to merge together as a single element containing the space. While this space can be compared to the room inside a building, far greater liberties can be taken with the former in departing from the rectangular than with the latter. In an indoor room the eye almost instantaneously sweeps over the planes and the continuous lines of their intersections to make the shape at once apparent, but in the outdoor "room" the walls are so far apart and the lines so broken that irregularities are unnoticed.

No plastic space body can be formed when the floor area is so great that the walls of the surrounding building bear no relationship to it. There is a practical limit on building height, but none on floor area, and it is found that a countless number of campus spaces fail because they are so large that the buildings appear to stand on the edge of the space. The walls and the floor of the space become dissociated and there is no sense of spatial enclosure (Plate XXXI). The large places for military and political ceremonies, which are a characteristic feature of autocratic cities from the eighteenth century onwards, are examples of this. A larger space can be less impressive than a small one; in fact, beyond a certain point, the larger the space, the less impressive it is. It is only in plan (two dimensions) that a large area can be appreciated. In actuality one looks across the space at buildings, and when one does, the greater the space between the observer and the facades, the less impressive they look. Furthermore, the greater the void around the observer, the less the sense of any spatial enclosure. The relation of vertical enclosure to horizontal plan must have a human scale if it is to be effective. There is a purpose for making a large space when it is to be used for demonstrations of military might or

political unity, although it is better to accept it as a two-dimensional floor rather than a volume.

To enclose space and not just occur in it, Sitte says the minimum dimension of a square should be equal to the height of the principal building, and the maximum dimension ought not to exceed twice the height, (depending on the principal building) (Plate XXXII, Fig. 1). Hegemann and Petle say that in order to see a building as a whole the observer should be at a distance equal to twice its height ( $27^\circ$ ) and to see a group as a whole the observer should be at a distance equal to three times its height ( $18^\circ$ ) (Plate XXXII, Fig. 2). Sitte says that the average dimension of the great squares of the old cities are 465 feet by 190 feet. It was mentioned previously that architecture cannot be reduced to a formula, and this is not an attempt in that direction. It is an approximation based on the observers experience and the effective limits of the visual cone. Since there are average dimensions to the squares of the old cities, obviously there is a point where spatial enclosure can be experienced and where it cannot. With the architects' understanding of the surrounding buildings and their effect upon the space, these dimensions should serve only as an indication of what has been done.



So far the study of spatial relationship between groups of buildings has been restricted to arrangements around squares, courts, and actual enclosure of volumes. It is stated in the definition of space that the present conceptions include a temporal element, that architects feel today it is insufficient (of course, there are exceptions) merely to arrange elements without a consideration of time and displacement for the viewing of these elements. The past dealt with civic squares, palaces and monumental architecture, and it was not until the philosophy included the only element justifying architecture, which is the fulfillment of human needs, that one finds an inclusion of time in spatial composition. Architects began to dissolve the complete enclosure which is viewed from within and entered a composition where the buildings are more freely located in space, and the observer is allowed and encouraged to walk around and through the composition to experience its mood. Whether functionally or organically, man is master and architecture servant, and man is no longer contained within a structural volume nor are the buildings necessarily arranged to suggest this volume, but are allowed to stand free in space and free as groups in space.

Buildings setting as a plastic mass in space, with no attempt to enclose space but only to exist within it, should

have a forecourt or visual space in front of their principal facades, across which their plastic qualities may be appreciated. This forecourt may be surrounded by other buildings which will give it significance as a space and will place controls on the views of the principal building, so that it no longer seems to float about in this open space. When the principal building is very large in scale or very individual in design, it is often allowed to dominate the space by being placed in the most prominent position and by keeping out of the space any other building which might compete with it. The space then appears to belong to the principal building; the other buildings form secondary walls and the composition may be regarded rather as a setting for a building than as a space in its own right. Instead of beginning with a space which we define by grouping buildings around it, we begin with one building and form a space in front of it; the building controls the shape and quality of the space, rather than the space controlling the shape and form of the buildings.

It is usual for the building to occupy one complete side of the space, so that the adjacent buildings are at right angles to it instead of on the same plane. The main facade may break forward into the space and the space can (and probably should) have objects in it such as benches, fountains,

trees, etc. to give it scale, but they must be arranged so that the vista toward the principal building is unobstructed. No formula can be set, as the design of the building will control the space in front of it, except that a tall narrow facade seems to suggest a deep space in front of it, and a broad and comparatively low facade a wide space.

The location of a plastic mass in space is not an enclosure defining the space, but rather a penetration of this space (Plate XXX, Fig. 3). The relationship between this space body and the surrounding walls, the scale of the body to the space about it, the space appearing to flow around the body, must be such that we are always conscious of this building mass. When a building of this nature is large in proportion to the space containing it, the latter is absorbed, or if the central building is very small it may appear insignificant in its space.

Buildings may be related so that their horizontal lines vanish to a common point (Plate XXXVIII, Fig. 1). This layout does not define space but does relate the buildings in space. It must have sufficient open area to allow visual room to see the buildings in relation to each other.

The problem is simpler when the viewpoints are controlled, either by grouping the buildings around a space from which they are seen as walls or by relating them by axial lines down which

there are controlled vistas. Formal relationships in space alone are rare in classical design. These buildings stand in space, rather than enclose or form it.

In considering the relationship of group "blocks" to each other we can at the outset dismiss the plan which is built up around enclosed light courts, and that which treats the building as so much street frontage.

A parallel series is one of the most used forms of layout for small schemes, particularly when combined with sensitive landscape design. However, there is a limit to the number of times the block may be repeated without making the environment monotonous. Standing between short blocks one has little sense of spatial enclosure because of the wide open ends, and without any terminal feature, the enclosure may be lost completely. With a tall scheme, the distance between buildings should be sufficient to plant large trees and thus break the view between the buildings and give some scale at the lower levels. With more closely spaced lower blocks, this is not possible, and when the blocks are very long, there is a tendency towards a tunnel effect.

Large schemes based on parallel series are usually too repetitious, and some right angle placing will help the spatial effect. Plate XXXIII, Fig. 2 shows how the short right angle

wing linking the two front blocks together gives definition to the central space.

It is not sufficient just to place the blocks at right angles around a rectangle and to leave it at that; we need to obtain definition to the space by correlating the buildings surrounding it.

In Plate XXXIV, Fig. 1 one block has been blacked in to show some of the different ways in which it acts.

From view (1) it forms the side of a space; but moving to view (2) one sees the end elevation; the block begins to stand in three dimension in the space, and the two adjacent spaces begin to be seen together; from view (3) the block helps to close the view beyond a space. As compared with residential structures, there are no height limitations, there is greater freedom in controlling the volume of the space, and variety can be obtained by contrasting high and low blocks. Thus in view (4) the block has been re-drawn taller than the others to become a dominant element in space.

There are many instances when the appearance would be better if the area between blocks was closed for its full height, by joining the blocks together. Plate XXXIV, Fig. 2 shows how some blocks can be combined into an "L" to close a view and thus enclose the space.

The permutations and combinations to be obtained by joining straight blocks into "L", "T" and "U" and other plan forms are too varied to allow more than a brief explanation of some of the more common types.

When a leg is added to the end of a straight blade and an "L" formed, there is a closed internal corner in one direction. A series of such blocks placed side by side defines rectangular spaces which can be closed on the fourth side by straight blocks or by further "L" blocks (Plate XXXV, Fig. 1). Or the blocks can be staggered so that diagonal views can be obtained between the ends of opposite blocks into the space beyond (Plate XXXV, Fig. 2).

The "T" is a form that does not make a satisfactory spatial enclosure when used in groups that are placed side by side in a single row (Plate XXXV, Fig. 3) as it produces an opening in the center of the space. If the rows are staggered so that the ends of the leg comes in the center of the opening, the defect will usually be overcome (Plate XXXV, Fig. 4).

When another wing is put on the "L" and a "U" is formed we have a favorite plan for use on the edge of an open space. The "U" block tends to turn in on itself and is too complete to combine well with its neighbors; placed in a row it gives the effect of every alternate space being undefined (Plate XXXV,

Fig. 5). The blocks can be staggered and will then form a series of rectangular closes. A row of "U" blocks can be joined together to form one continuous block and form a fret pattern. This fret block arrangement gives a more interesting pattern of contrasting and expanding spaces.

Direct-grouped blocks are usually such complete and complicated forms that they are usually left in three dimension rather than used as walls to a space. Thus, cruciform blocks can be placed quite happily together to form one long block, (Plate XXXVI, Fig. 1), but when another block is placed at right angles to it, the adjacent wings tend to form a partially enclosed dark corner (Plate XXXVI, Fig. 2). When, to counteract this, one building is moved away, it at once tends to dissociate itself (Plate XXXVI, Fig. 3).

Another common form, the three pointed star, can be strung together in a series (Plate XXXVI, Fig. 4) or may be assembled to form a hexagonal space (Plate XXXVI, Fig. 5). The background itself may be used to form a space in which the tower stands; in this way there is both a sense of spatial enclosure and of a plastic composition standing in space.

When it comes to grouping buildings to form a spatial composition, it is found that the arrangements most suitable for flat land are the least satisfactory for a slope. On an even

slope spatial groupings will be most difficult because of the constant change in elevation, but on undulating ground there will be many opportunities for relating the buildings to each other to give a sense of enclosure. With a natural bowl shape, the form of the land itself may be exploited to form a space. An undulating building may follow the contour of the land and form a space wall. The rectangular disposition of the other buildings for spatial enclosures and extension follow generally the slope of the ground also. While volume is not directly defined, nevertheless the sense of spatial enclosure at the lower level is well established when integrated with the landscaping.

The architects of Greece and Rome designed the temple to be the dominant object in an architectural space setting. To underline its importance they raised it on a stylobate above the general floor level. Changes in floor level by means of steps or ramps (thus introducing horizontal planes) will add to the interest of the space and act as a transition as well as define the edges of the spaces in a vertical direction.

The method of defining space at the lower level can be utilized to solve the problem of spatial enclosure with multi-story buildings. Many earlier skyscrapers were developed in pyramidal form and when arranged together produced an overpowering effect of mass, reducing the space between buildings



(across the street) to a dark chasm completely without scale and feeling for space. With the introduction of the vertical slab penetrating the space above and by bringing together the scale, size, and character of the architectural elements of the lower level (always present as stores), a feeling of space enclosure has occurred at the lower level, freedom of space of the upper level, with the plastic bodies in space. This will give visual impressions: the internal spatial enclosure at the ground level--the sense of space body, and the interplay of plastic forms in space above--the sense of masses related in space. This idea is in the Rockefeller grouping around the central plaza, but while one may well be moved by the spatial relationship of the towers, the spatial enclosure at ground level is too restricted and confused by traffic to be really significant.

## AESTHETICS

### Space

In approaching the problem of establishing correct or aesthetically desirable spatial relationships an architect must remember that the space was there before him and will be there after he leaves. What he does with this space and how he forms it may involve great mental activity for the philosophy

of this formation or may simply involve the manipulation of a few architectural elements to create the desired effect.

Either way the emphasis is on the means and the results. The transformation of a huge void to a positive entity for human needs and how it is done is the architect's concern.

Space can extend in all directions with framed views between buildings (Plate XXXVII, Fig. 1). Buildings may be pierced at ground level to allow unexpected vistas, relate one space to another, or allow the eye to scan an adjacent landscaped area (Plate XXXVII, Fig. 2). Space may be designed with a third dimensional object at different levels, (Plate XXXVII, Fig. 3) and upper stories may be lifted up from the ground planes to become free standing volumes related in space (Plate XXXVII, Fig. 4).

The design of groups of buildings is chiefly concerned with the formation of space relations between the buildings. First one must regard the natural landscape itself as a broad open space to which the architectural group is related, a space which provides a setting or foil to the built up areas. If to this space one adds all the areas of open landscape such as landscape ways and parks he has a type of "open space" as opposed to built up areas of buildings and roads. A single building (Plate XXXVII, Fig. 6) standing in an area of open

landscape will appear as a plastic mass in space. If the building has a facade of some width and if in front of that facade is a flat floor plane, the eye will be arrested by the building and brought down to the floor. The floor or horizontal plane and the building begin to bear a relationship to each other, and they begin to define a space related to the larger open area in which the building stands (Plate XXXVII, Fig. 5). This begins to become a space body - the reverse of the plastic body of a building. The significance of this space is not so much that it is an area on which buildings look or an area in which to view the buildings, but that it has an existence in its own right. Although intangible, it is one of the chief raw materials in building group design, one of the elements to be manipulated by the architect in his process of organization.

### Relationships

Aesthetic relationship between buildings and building groups are mentioned here to establish that they must be recognized, utilized and appreciated to complete any physical design. It is not the intention to elaborate on any one element, but rather to establish some definite and basic associations between these design elements and campus planning, to acknowledge that there are certain essentials, necessities and

desirables; that no group of inter-related buildings can be conceived and planned or can properly function without due consideration for the whole, the same considerations that would be given any single building. Not only is there an apparent lack of ability amongst top designers, but also there exists little written material concerning the design of the whole. Disassociation rather than relationships seems to dominate any group design. The parts command great time and effort but no one seems to be concerned with the whole. Part of this difficulty can be attributed to the client. In his desire to divide the work among the many architects who are competing for his favors, he fails or neglects to appoint one to see that the individually designed parts are integrated into the whole. In some extreme cases, such as the University of Mexico, there is a co-ordinator whose function is to see that the entire complexity becomes a unit. But usually there is no co-ordinator, no overseer. Even in those states which maintain state architects to supervise or design state schools, there is no overall plan that merits discussion. Buildings are haphazardly located at the whim and discretion of the department which will use the building. There are many examples of chaotic conditions to support this statement.

There are many ways to relate buildings. As previously said, they will be only mentioned here, as it is felt that each one is important enough to merit a thesis.

Architecture can thus be understood in three ways - three levels, if you like. One, the creative intention of the designer; two, the potential evocativity of the structure itself; and three, the response of the observer. (Raskins, 21), p. 10.

The abstraction 'architecture' tracked down to its referents, becomes a trio of emotions--emotion intended, emotion inherent, and emotion evoked. The common element is emotion, and if one must use a single term to define architecture, that is it. Architecture is emotion. If the emotion is mild, so is the architecture. If the emotion is great, the architecture is great. If there is no emotion, there is no architecture, there is only building. (Raskins, 21), p. 10.

This quotation from Raskin's excellent book establishes the criterion for the judgment of these design elements. Each person can and should judge them to the limit of his abilities, always remembering that his expressed judgment is an exposure of his sensitivity and maybe even of his capability and intellectual development.

Sequence is a function of time and motion and is inseparable from the perception of architecture. The first sight of a building group from a distance will be its silhouette or its mass. As one moves closer to it he will see and be able to distinguish its most important parts, its dominant elements, its initial appeal. Finally, upon arrival he can see its details,

its secondary and subordinate elements. All this took time, involved motion, and was a sequence. The initial impression forms a background upon which anticipation and excitement can be created as one approaches closer and closer and finally arrives at the group. This preparation is the essence of sequential art. It is profoundly used in all art expressions. Respighi's "Pine Trees on the Appian Way" is an excellent example of this. The initial or early sounds establishes a level of volume from which later swells can be judged. What one hears first is the basis for later judgment. So it is with architectural design. The first impressions provide the background for later judgment, and each visual step from first silhouette to final detail is enjoyed and appreciated because of previous sequence of preparation.

Volumes and areas appear in size as a relation to the previous sequence. That is, upon entering an enclosure one immediately compares its size with the larger space of the exterior; thus a large volume will feel small compared with the immediate exterior, and a small volume may feel very small and uncomfortable. It is necessary to recognize that in group design, exterior volume will influence the immediate feeling of the building lobby or vestibule. This exterior enclosed volume should be kept small enough to serve as a reasonable transition

and sequence between the great space of undefined area and the building enclosure.

Sequence must be handled as a chain of progressive design elements leading to a logical climax. All forms of art have a climax and a series of sequences leading directly or indirectly to that climax. Music, dance, painting, drama and literature all have a sequence of events or elements leading to a climax.

Sequence, then, besides being a progression of elements, must be a progression towards an architectural climax. It becomes very important in conditioning the observer for this climax, and the impact or lack of impact may be a result of the sequential conditioning. This becomes a basic consideration in leading the observer into or between building groups. The effect upon entering the group enclosure will be a result of previous conditioning. It must be realized that what is a progression in one direction is a regression in the reverse direction and must be capable of conditioning and stimulating the observer while he is approaching, leaving or circling the designed group.

Scale is a measuring instrument marked off in units which serve as referents of length, weight, force, and time. A scale is also a proportional device capable of being used to enlarge or diminish the pictorial representation of an actual

object. Thus it is possible to show a piece of architecture at various proportions of its actual size. It can be reduced to a third, a fourth, a ninety-sixth, or some other reduced proportions. It can, and occasionally is, enlarged to twice or three times or some other factor of the actual size. Many examples can be found which are "scaled" from their actual size, especially in the realm of hobbies, boats, cars, and many others. Having seen the full-size counterparts of these models, we become aware of the miniature and its relationship to the real object. We recognize this relationship between the scaled model and the real thing and subconsciously make the transition between reduced scale and full size. We may remark upon the exactness, realism, or novelty of the model because we are comparing its scaled size with the size that we associate with the full-size object. This then becomes a problem in association and probably association at a subconscious level.

When one looks at an actual building, he is seeing the image that is cast upon the retina and transferred to the mind for interpretation. He is seeing dimensions that are less than actual full size and that are also reduced to the size of the retina's surface. Distances prevent us from ever seeing an object in true size and shape. Normal vision introduces perspective with its receding and fore-shortening. By the laws of



orthographic projection and descriptive geometry it is impossible for us to ever see any dimension in its full size. To do so would require the use of only one eye and at a distance that would be too close for the focal powers and function of the eye. True, the amount of reduction may become very minute, but it still exists. It follows that the greater the distance between the object and the observer, the greater the reduction. From fifteen thousand feet, a university campus becomes very small and insignificant, hardly distinguishable, and the small rural communities disappear.

Through association, however, we compensate for this reduction. We see the reduced dimensions of the object, but we think the actual size. We mentally reconstruct this image in its actual size and shape and thus become aware of its actual size. Time and distance being two factors that change as we approach, go around, or pass through a building or building group, the relationship between retina or seen size and actual size is constantly changing as the observer's position changes. The eye is constantly flashing a series of images which the mind receives and interprets in order that we may imagine the size through association. An object seen without reference to any size or scale indicator and not previously seen, cannot be correctly interpreted because of a lack of association. Pic-

tures which contain no scale indicators cannot be interpreted. Scale interpretation is an association process, and without the referents with which to associate, we cannot conceive of or determine a given size. Scale indicators and associations are necessary for successful building and building group design. A design that does not provide this causes psychological irritation to the observer. He cannot determine or establish a relationship between his own size and the size of this physical grouping. This may vary from mild dissatisfaction to complete disapproval. In building groups the problem of scale is that of easing the recognition of the observer with regard to the structures. Not only is it a matter of making size and distance discernable, but easily and agreeably so. Indicators with which the observer is already familiar must be conspicuously placed to facilitate the orientation towards scale. Those features with which he has had the closest contact can be architecturally featured and functionally placed. Therefore the designer should use elements which are readily and easily associated in size with the human body: handrails, stairs, seats, shrubbery, walks, trees and other easily recognized elements. Of course it is possible, by the use of exaggerated or reduced scales, to create areas that are intimate that create a sense of ease, a sense of mastery over the area, an intimate scale;

or through monumental scale, in which everything is larger than expected, to create a sense of awe, to impress the observer and to fill him with a sense of pride or humility. As intimate scale tends to swell the ego, monumental scale can shrink the ego and create a sense of oppression or fear. Frank Lloyd Wright's gardens and entrances are excellent examples of intimate scale as is the Lincoln Monument an excellent example of monumental scale. Regarding application and effectiveness of these scales, Raskin states that,

It is worth noting that both intimate and heroic scale depend utterly upon the existence of normal scale in the majority of architectural work. If the eye were not trained to expect certain sizes as normal, the smaller-than-normal of intimate scale and the larger-than-normal of monumental scale would have no meaning at all. In other words, and this is the meat of our scale analysis, a given building has no inherent scale quality of its own. Its scale effectiveness lies entirely in the relationship between its scale and the complex of other existing architectural work. If this is true, and I think I have demonstrated that it is, we can never look at an architectural creation separately. There is no piece of architecture apart from all architecture. It follows also that there is no architect unless there be architects. The solitary genius, creating in inspired isolation, does not exist, except perhaps as a state of mind. (Raskins, 21), p. 50.

One of the primary purposes of a campus is to create atmosphere conducive to learning. Scale, as a basic design element, must be carefully handled to achieve this desired effect. What scale should be used is not important here. The specific circumstances will provide the answer for that. Certainly

planners must not overlook the induction of features into the overall plan that will set an aesthetically desirable scale. Whether intimate, normal, or monumental scale should be used cannot be said. Probably all three with normal scale being complemented and relieved by intimate and monumental. Caution should be exercised, however, in using monumental scale. Monumental treatment of such a standard building as a library is questionable. A more effective use of these buildings and their contents could be achieved by reducing the scale. One does not have to be humbled and awed to show respect. Intimate scale with landscaping and its features can do much to enhance the space and area within and between buildings. Not only would a more effective library design result from the use of intimate or normal scale, but the psychological factor could become important in promoting and continuing those attributes theoretically found within the campus.

The word "unity" means oneness, not oneness as defined by singularity, but oneness that is accomplished by putting together of things, the combining of things into a group to which we can then refer as possessing the quality of oneness. Unity is not an inherent quality that is possessed but rather a quality that is attributed.

To establish unity it is necessary to have a clear understanding of the nature and function of the composition. To accept a composition as having unity one must know and recognize the functions of the parts as they serve and become functions of the whole. Without this understanding and recognition the observer does not see a oneness and in his opinion then the composition lacks unity. Unity, as a man-made factor, exists in any composition only to the extent that he thinks it exists. It becomes a value judgment and valid only to the extent of the ability of the person judging.

Through long association one accepts the car as having unity, yet pictures of the first "horseless carriage" lack unity as it does not have those features generally associated with the carriage and the car; there is no horse and there is no cover. So because of inexperience and inability one sees discord in this mechanical gadget. Existing Georgian style college buildings have unity for some people yet lack it for others. To some people Georgian is the appropriate style for college architecture and if the early campus buildings were built in that style these people feel the tradition should be continued. But to build modern buildings in a historical style is anachronistic. The early cathedrals had the quality of unity for one expected that type of construction with flying

buttresses but to repeat one of those cathedrals today and expect them to have unity is to overlook the newer construction methods and such materials as prestressed concrete. In the twelfth century they had unity; today they would not. The human body is one of the few objects that possesses a continuing unity. Human evolutionary processes are too slow for people to notice any radical changes except over periods of many thousand years. Human use being the purpose of architecture, people in almost any physical containment do not distract from this unity; to the contrary, they add to its unity.

In the case of abstract painting or sculpture, the card index search takes place at a level of subconscious association. Forms, colors, patterns which one does not identify in any representational sense suggest not objects or concepts but the emotions associated with them. To respond readily at this level requires considerable sensitivity, willingness and training. It takes practice to turn off the conscious, verbal faculties deliberately and allow delicate combinations of feelings to float up to the surface of perception. That is why one sees so many bemused faces at exhibitions of modern art. And that is also why those people who have neither the sensitivity, the willingness, nor the training to go through this process are so contemptuous of all modern art and so sure that it consists entirely of charlatantry. (Raskins, 21), p. 28.

With reference to a building our recognition of concepts is tied up closely with the expression of its function. The observer must recognize the building (and subconsciously assign a function) to determine unity. Through long and many times false associations he identifies stylistic forms with certain

functions. Gothic and chapel are as easily associated as the cross and Christianity, and herein lies the difficulty in obtaining unity in contemporary architecture and planning. The "round palace" at Wichita University (by itself) has unity, the Kansas State College fieldhouse has "bigness" yet both, acknowledged as such or not, are primarily for the function of basketball.

Campus unity then becomes a problem of expression through function using devices such as form, color, scale, and harmony. Inasmuch as unity is a visual sensation, only the eye which understands the function and nature of the grouping as a whole is capable of perceiving unity or the lack of it. Unity is limited by the visual senses to an area that can be seen and understood. An entire campus should have good composition, but since one sees only part of it at a time, his judgment of its unity will be on the basis of its individual parts. The planner must conceive of it in its entirety, however, he must mastermind all the parts into the groups as well as the groups into the whole. Unity is achieved in the initial planning stages through functional relationships of architectural devices.

The capacity to respond to rhythm appears to be inborn, where as the response to scale and unity seem to be conditioned responses and associations. Rhythm is a part of the life

process. A man breathes in rhythm which takes place in a larger rhythm of sleeping and waking, which exists within a larger rhythm of the sun and the seasons. These generalizations form a rhythmic procession. One of the conditioned abilities of the mind is that of translating a pattern that is received visually into a rhythm that acts as a stimulus that was received aurally. The elements of the visual pattern, separated by secondary elements of space, act in the nature of beats separated by gaps of time.

The time factor involved in the visual perception of a pattern depends on the distance between the elements. Closely spaced elements can be scanned more quickly than widely spaced ones. Thus the time gaps which establish the tempo of the visual rhythm are determined by the actual spacing of these elements. More closely spaced elements create a fast tempo, whereas widely spaced elements create a slower tempo, and the elements may have secondary elements placed between them which will tend to change the beat and tempo.

Rhythm is essentially repetition. This does not necessarily infer that this repetition must be with the same or equal elements. Columns, window mullions, recesses and projections, light and shadows may be so designed as to establish and carry from one to another the same tempo, yet they are not



the same nor are they necessarily equal elements. There may be a repetition of elements whose differences progress uniformly. The units of the rhythmic pattern may get larger or smaller as they go along, varying either by the same amount or in the same ratio. The tempo is slowing down or speeding up, depending upon the direction from which they are viewed.

Augmenting and diminishing rhythms may be established by the arrangement of the elements whether they be the smaller elements of an individual building or the buildings themselves as elements of the group. Many geometric forms such as the conical helix and the volute are instances of swelling and shrinking rhythms. A diminishing rhythm is a growing rhythm in reverse. Therefore, what seemed an augmenting rhythm during arrival will seem a diminishing rhythm during departure.

Considered with the other elements of design, rhythm can be used effectively in creating the desired atmosphere and mood. Careful consideration should be given to pedestrian ways and the transition between building groups, to the entrances of groups and quadrangles and with the placement of landscaping.

Proportion cannot be discussed except in reality. There is no theoretical quality of proportion except as it is directly applied to specific elements having real dimensions.

With regard to quadrangles and building groups we must consider their functions. To accumulate and hold a large gathering requires a different size (and therefore proportions) than the small intimacy of an informal landscaped area. These two serve different functions and therefore these areas and their space walls or enclosures should have different proportions. To try and apply rules, laws, systems and devices of numerical value are futile and have no value in establishing proportions. Good proportions for a physic laboratory are not necessarily good proportions for a home economics laboratory of similar size.

Scale is a function of proportion. The proportions between the parts that constitute the whole will vary, but in no strict ratio, as we change from intimate to normal to monumental scale. What is pleasing at intimate scale will become irritating and disastrous if the same proportions are maintained in monumental scale. A seven-foot door for a one-story classroom does not become fourteen feet or larger for a gymnasium. The proportions associated with size help to determine the scale, and to violate proportions of easily recognizable objects will destroy the scale and provide undesirable proportions.

Finally proportion is a function of time. Upon entering any area one is never immediately conscious of all the details

and intricacies the area contains nor in their proportional relationships. It takes time to view the area and see these minute details, as in approaching a building group. From a distance the details are not distinguishable and one is conscious only of form and outline and proportions. As the distance diminishes the detail becomes apparent, and one becomes aware of proportions between these parts and the entire composition. Time also changes attitudes toward proportions. As an indication of this observe the female form whose "desirable" proportions have been constantly changing. Sculptures and paintings of this form show the changes that are constantly occurring. Compare Greek statues with today's ideals, the Renaissance with the nineteenth century and 1925 with 1958.

Architectural composition is the putting together of things in such an order as to control the visual experience of the observer, to force the observer to see only those things at that time as the designer wishes. As a musical composer allows the listener to hear only those notes he wants to and in the order he wants them heard, so should the designer of building groups allow the observer to see only those elements he wants and in the order that he wants them observed. The difficulty is in controlling the time and space elements. The designer cannot make the observer look from left to right if

the observer wants to look from right to left, and the designer cannot rigidly control the observer's station point. The best he can do is to arrange the many elements and devices of harmony, sequence, scale, unity, and topography in such an order as to control the maximum visual directions.

Relationships are imperative to composition. The spaces between buildings in the groups and the time element in changing or in constantly changing viewpoints will establish these relationships. It is known (actually it is assumed through association) that in numerical relationship the ascending order is 1, 2, 3, 4, 5, etc., and the relationship of 2 following 1, and 3 between 2 and 4. In music the order the notes are played makes a melody and the relationship of notes makes harmony. So it is in building group composition that the buildings form the melody and the time and space relationships between them create the harmony. Composition becomes a system of logical and aesthetic organization and placement to convey or confirm their relationship and interdependence. Groups can be formed around academic functions, around curriculum bases, around social necessities or many other logical bases.

The total purpose of composition becomes one of leading the observer through a logical sequence of planned experiences during which time he can recognize (consciously or subcon-

sciously) physical, ordinal, and relational qualities which makes the grouping an entity, distinct yet related to other similar groupings and capable of conveying an architectural emotion.

Function refers to the fact that man-made objects take shapes and forms suitable to the function which they are required to perform. Wheels are round so they can roll, steps are small changes within a larger change to facilitate a change in elevations, and buildings have walls, floors and roofs to protect their contents from the elements. The shapes, sizes and forms of buildings should be in accord with the specific needs they are required to perform, recognizing the unpredictability of human behavior. To be completely functional the best building group would probably not be a group at all but one building stacked on top of another building to eliminate unnecessary movement between buildings, to expedite changes between classes, to reduce horizontal circulation (and increasing vertical circulation) and to locate centrally all classrooms, offices, and other facilities. This may be more functional but it overlooks sequence, character and other elements as well as undesirable psychological effects of imprisoning its occupants. Function then becomes a compromise between strict functionalism and functionalism with consideration to other design objectives.

The function of any group can be determined only by the persons studying that group. A group should be shaped and moulded around its function but with consideration for the fact that composition, time, space and other relationships are parts of that function.

Character is a value we attribute to a piece of architecture, which in reality is the designer's opinion of the function and expression of that building. It is accomplished by the accumulation and manipulation of the various elements and devices of design. In the Lincoln Memorial it is the designer's opinion of Abraham Lincoln. By use of monumental scale, rhythm, axis, sequence, the designer has given this memorial a character, as the designer feels one should be awed, humbled and respectful towards this past president. The character of the building is the opinion of the architect. All buildings and groups have character. It may vary from no expression to mediocre to a highly sensitive expression. Where the architect's opinion is most clear and most clearly formed, the character of the building is most definite. Building groups that are uncertain or poorly related, have virtually no character. Areas and enclosures are loosely defined as if the planner was uncertain as to what to say, where to say it, and whether it should be stated at all. The character of the area fails, for one has no

desire to enter it or leave it, there is no definite statement, no character to express an invitation or rejection.

The firmer the opinions and convictions of the designer the more the character of the design will become apparent. Whether the observer agrees with the expressed character is of no real consequence. Right or wrong, the opinion has at least been expressed, the buildings and their group cry aloud with character, with their opinion of the reason for the area, the purpose of the areas and the function of the area.

Honesty is the integrity of the architect in establishing and expressing the architectural character which he feels should be expressed. When the architect lets a board, a committee, or another individual define and establish this character he does so at the expense of his professional integrity and honesty. Honesty is simply the development of character on the premise of "this I believe."

The word 'style' is an abstraction of a particularly high order in that it concerns the manner in which things are done. Manner, in turn, is itself an intangible quantity, depending upon the perception, interpretation and recognition by an observer of the specific items which identify it. Style can exist, therefore, only insofar as our eyes and minds are trained to select and appreciate similarities and differences of manner. (Raskins, 21) p. 15.

The connotation is that style is the manner, and manner is the individual means of interpretation. This being the case,

style becomes the personal expression in our endeavors: our style of handwriting, of talking, of walking, of type and choice of dress. All are mannerisms peculiar to the individual and his personality. This style as a personality expression will identify the individual only to the extent that his personality is individual and different from others. Raskin's further states that it is the greatest men, the ones with the most individual styles who are the loneliest of men. The fact is that this personality, this style, this manner is so far removed from the average of this period that quite frequently he is unrecognized and because of this, unrewarded until long after his death. History books are biographies of these many individuals whose styles rose above the many probably to be rejected by their contemporaries. It is because of this that the mediocre style which persists everywhere around us is only the product of mediocre personalities. A definite individual style can come only from a definite individual personality, which is probably the reason that those few men whose styles are strongly personal are such controversial figures.

Style, in history, refers to those periods of culture in which are recognized similar mannerisms. While the people of a certain period were different individually, the products of their time were alike and akin because of their inter-associa-



tions. Thus similarities, distinguishable from the similarities of other periods, constitutes the historical type of that period. Style in campus planning then is an expression of the abilities and personalities of the persons who plan its physical structures. The created campus style speaks in establishing and defining the very philosophies, ideals, goals and dreams for which the university, in theory, stands. Its well functioning physical plant transforms its ideas into type and styles. This style for any campus is no more and no less than the attributes that can be found within its physical confinement. It is the unique personality of the university. Acres of parking establish this, random-placed buildings establish this, landscaping establishes this, orientation establishes this, the creativity and leadership of the person or committee which performs the planning functions establishes, defines and commends or condemns the style the campus possesses. Campus style, therefore, is a reflection upon those persons directly responsible, those who choose the architect, those who appoint the committees, those who accept present practices, the administration.

All the examples shown in the appendix as blocks (except actual constructions of proposals) are without scale and dimensions. This is not an oversight, but an intentional omission.

Numerical dimensions are of little value alone. Saying that a space should be twenty feet by thirty feet by fifteen feet has only a vague meaning until you know the treatment of that space. The psychological effects created by the use of materials, colors, lights, shadows, textures, can give the same dimensions great variation and can cause the area to seem many times larger or quite small. Size alone is not necessarily the controlling fact in obtaining desirable space relationships; it must depend on many complementary elements of design. Space is the root of architecture. Its creation depends on its use for human needs. This creation and organization of space relationships between building groups or between individual buildings or within the building itself must be concerned with the use of that space by man, how it will affect him and how he will affect that space. Such is the present thinking, if not in professional practice, then at least in education. The failure to recognize a building in its space relations with its urban area will probably result in an architectural failure, not to be buried but kept, maintained, preserved, and published, not as a failure, but as a "piece of architecture," even if it cannot fit the definition.

This contemporary practice of the recognition of the relationship between buildings has caused architects to discard the

past use of rigid plans. Rockefeller Center, the Back Bay Center in Boston, the South Boston Redevelopment, Drake University and many other examples show the constant attempt to find a better solution than the pure use of geometry. Designers seek that something which was lost with the building of the past piazza. This is a period that is beginning to understand that the pleasantness and serenity of the ancient squares was due to their recognition of space, and while it is not necessary to enclose space to recognize it, one must nevertheless realize that the space surrounding a building or existing between any two adjacent buildings is an important design factor which may spell success or failure for the entire architectural composition. This should be evident, as its existence (the lack of space recognition) is prevalent in the majority of building groups.

The architect must acknowledge that space is the essence of building design, that in the design of groups of buildings the relationships between buildings lies in the space they define. The failure, intentional or otherwise, to recognize the function will only add to the misery of the existing cities, which are already beginning to be considered as places to get away from, not to enter or enjoy. This is also true for any situation which includes groups of buildings. When any two

buildings are situated so as to define a space between, some recognition must be given to this space. A relationship, by design, must be established above the function of the buildings if they are to be completely successful.

Such is the trend amongst the most contemporary architects; to develop plastic masses in space, related to one another in space, enclosing the space, penetrating the space, and complemented by the space; using all the other elements of good architectural design to reach this complete recognition, constantly aware that architecture is not art for art's sake, but art for human environment.

#### APPLICATION

Since about 1900, the theory of architectural design began to develop toward a more free and open plan and the design of building groups became more free and open. Civic centers, shopping centers, schools, campuses, became buildings in space or merely suggesting spatial enclosure, rather than the rigid geometrical shapes and forms of earlier periods. This present tendency is partly due to the architects' relating the buildings and building groups to the community and surrounding areas as a part of the community and urban areas. The architects feel that each building must be related to its surrounding features and

must both complement and be complemented by them, rather than remaining a rigid, self-contained unit which fails to recognize and even ignores its related surroundings. The need for future expansion of the physical facilities, the actual alteration of the present plan, can be accomplished more economically with an open and freely designed building than with a rigid geometrical composition. Thus while it retains and recognizes the original arrangements, it is still designed so that future additions can be accomplished without destroying the effect of the original design.

The design of a campus, Kansas State University, 1980, is shown in Plate XXXVIII. This plate, showing the entire campus except for three residential and one public area, is divided into numbered areas which refer to subsequent plates. Plate XXXVIII is included to show general relationships between areas and the overall composition of buildings. Walks, covered areas, building connections and landscaping have been eliminated and only the major buildings and groups shown.

Spatial definition can be seen in the building arrangements. Areas are defined by enclosures, quadrangles, space walls and the position of one building in relation to another building.

A major north-south axis and a minor east-west axis passes through the physical and academic center of the campus, the

library. A secondary axis passes through the auditorium (a public area), the library and the public areas of the student union.

Buildings are grouped according to functions, and areas are designed around these groupings. Compare this Plate with Plate XXXI, which shows a scattering of buildings over a disorganized plot. There is no definition of areas, and space relations between buildings are not defined. Parking occupies large land areas and a functional relationship between colleges and schools does not exist. The center of the campus is occupied, not by a library or academic function, but with a social and public building, the student union. Public, academic and residential areas are so intermixed that the campus serves as a traffic way connecting these elements. Quadrangles, enclosures, groupings, landscaping and space walls cannot be determined. Residential areas are adjacent to academic areas, and public areas are accessible only by streets that divide the campus into many small and indefinite areas. A major north-south street divides the campus into an east-west area, not for function but for convenience. Such divisions not only divide the campus physically but separate its academic functions and faculty relationships. Continuation of such a haphazard scheme cannot provide the physical plant nor create the environment

necessary for the successful accomplishment of the university philosophy as stated by the various curricula.

The symbolic entrance to Kansas State University, 1980, is shown in Plate XXXIX. A four-lane split access is provided for ease in entering the campus and this access leads directly to parking areas adjacent to administrative functions. This allows the public to enter the campus, use the chapel and the offices of the president, the registrar, the director of admissions and other administrative officials without encroaching on academic schedules or interfering with student traffic. Periphery parking is located along the east boundary of the campus. Landscaping has been maintained as a buffer between the city and the campus and as a design element to complement building units. The buildings shown are existing buildings, and the major design changes have been made only with the streets and pedestrian walks.

An academic grouping adjacent to the administrative units is shown in Plate XL. Here the academic grouping has been composed around two enclosures. One enclosure is entirely academic, while the other uses an administrative building as a space wall to define the area. Covered walkways connect the various buildings, and it is possible to move throughout the entire group of buildings with some form of weather protection. The two en-

closed areas are separated by a building and covered walk that defines the two areas and acts as a separation between them. Landscaping must be freely utilized to close the open ends of the enclosure. This grouping is composed of existing buildings, proposed buildings, and suggested buildings. A large parking area is provided to the west of this grouping.

The athletic grouping shown in Plate XLI is composed of existing buildings and their proposed additions. The student union is a part of this public group and serves as both a public and a student facility. With buildings of this size, real spatial concepts are difficult to develop except within the area of the individual building. Landscaping becomes an essential design element in creating harmony and unity and maintaining a human scale in the composition. Parking is provided to the north of the area and ample public parking is provided to the east and west of this grouping.

The composition illustrated in Plate XLII is an academic arrangement for the school of engineering and architecture. This group is composed of several interdependent enclosures separated by visual obstructions. To the existing engineering building there have been added classrooms and laboratories to give a contained area. Although not shown on this two-dimensional plan, buildings have been raised to allow space and view



to flow beneath them. The former street that separated this area has been reduced to a pedestrian way with restricted use for emergency vehicles. Three minor enclosures are distinguishable and a major enclosure is defined. Two minor enclosures are separated by a visual space wall and actually flow into each other. The existing power plant, with adequate landscaping, forms the east side to the major enclosure; the existing engineering building closes the south side; and the suggested buildings complete the enclosure to the north and the west. The buildings are interconnected to protect the students during inclement weather. The military science building has been treated as a mass in space and remains separated from this grouping, left to face the military parade field.

The academic group shown in Plate XLIII contains the center of the campus. The library lies on the intersection of a major, a minor and a diagonal axis. It sets as a mass in space completely surrounded by space walls. Except for the mislocation of the hospital and auditorium-classroom, this entire enclosure shows well defined limits and areas. Because of the size, landscaping in minute detail is employed to give a human scale to the enclosure. Smaller areas, defined by walks and landscaping, are contained within and constitute the larger enclosure. Existing, proposed, and suggested building locations

have been employed as space walls. Covered pedestrian ways provide protection and architectural connections throughout the entire group, except to the library and hospital. This makes it possible to pass from one building to another throughout the entire group with some protection from the natural elements. A major walk passes through this grouping and faeder walks lead from it to the various buildings. Primary and secondary walks are used with major and minor areas and suggested enclosures. Parking is provided to the north of this grouping.

The buildings shown in Plate XLIV are a composition of academic classrooms, a student-public auditorium and residential scholarship homes. It is composed around two smaller enclosures which constitutes a large enclosure. Two buildings forming the space walls are open at ground level to allow views between areas. The auditorium (composed of two theatres) forms the enclosure for one end of the area and faces onto a developed lake and landscaped area. One-way streets which lead directly onto and off of the campus are provided for the public's ease in attending functions in the auditorium. These streets lead to large public parking areas north and north-west of the auditorium.

The existing street, which passed north and south through the area, has been restricted at both ends and now serves as a

major pedestrian way and access for emergency vehicles. Minor walks feed from the major walk into the several buildings. Interconnections are provided between the buildings for weather protection.

The home economics building does not form a part of this enclosure but is an appendage attached to the enclosure. The scholarship houses are separated from the other functions by adequate landscaping that serves as a buffer between non-contiguous functions.

The women's dormitory area of Plate XLV consists of existing and suggested buildings. The existing group displays a formal arrangement with right angle relations and straight walks. The openings at the corners are too wide to allow a visual sense of enclosure and exterior volume. In the suggested arrangement the same general scheme has been repeated, however, the buildings have a closer relationship to each other. A better sense of spatial enclosure has been established by reducing the physical size of the openings between the buildings and overlapping the ends.

The area is separated from adjacent areas by trafficways and an artificial lake. The women's gymnasium and play fields are located adjacent to the living quarters. Periphery parking is provided on the east side.

The academic building of Plate XLVI is an existing structure with little physical relation to adjacent areas and groupings. It is surrounded by streets which tend to set it by itself. Landscaping was employed as a device to develop the area and visually limit the space surrounding the structure.

Plate XLVII is composed of existing and suggested buildings of an academic and public function. The suggested buildings have been arranged to complement the existing structures and to create suggested areas of enclosure and containment. Parking is provided adjacent to existing buildings and in an area south of the group. The buildings are interconnected by covered passage-ways and are fed by minor walks that lead through the area. Landscaping has been used as space walls in an effort to give visual expression to the space and reduce the large area into smaller areas that are recognizable.

The men's dormitory unit of Plate XLVIII is a group of existing buildings that have, through the use of landscaping, fences and other design devices, a relationship that lends itself to a natural defining of areas. Walks passing through the area and interconnections between buildings offer a visual aid in establishing these defined spaces. Additional landscaping was employed to separate this area from academic areas. Resident parking is provided on the north and east sides.

A series of interrelated, similar, existing housing units is shown on Plate XLIX. Small areas are defined by landscaping, walks and building walls, and a large area is defined by building shapes at the extreme edges of the area. The open area is adequate for the building locations, and periphery parking is provided.

The four units on the south side do not work as effectively as the others. Their positioning destroys any exterior volume between them and the parking area tends to make them street facades. Landscaping defines, to a limited extent, surrounding areas, but the natural sense of enclosure has been destroyed by the structure placement.

Additional dormitories are shown in Plate L with the same arrangement as the existing dormitories of Plate XLVIII. Again the location, the shape and the interconnections greatly facilitate the ease in establishing areas of well defined space and space volume. Landscaping, as an aid, screens the general area and closes open segments between building planes of intersection. Similar shapes of buildings in different locations will aid in establishing overall unity for the entire campus. Repeated shapes occurring frequently greatly aid in a subconscious recognition of continuity throughout the entire design. Play areas are with the grouping and parking is provided on the west side.

The suggested amphitheater drawn in Plate LI is located north of the existing campus in a natural bowl. Parking is south of the acoustic shell and separated from the bowl by landscaping. The site is adjacent to a public street and easily accessible for both university and public uses. This area is not physically connected with other campus buildings, but is designed as a separate element. Its function as an outdoor theater dictates the topography required, which should be used in its most natural setting.

The residential grouping of Plate LII is an arrangement for faculty housing. This suggested unit does not need to be directly connected with the other campus facilities or other residential groupings. In this type of composition thought should be given to orientation, view, privacy and other elements necessary to the design of a residential composition. Adequate land area and provision for parks and play areas for children are essential. The design of the group must be approached as individual units adjacent to similar units and not as repetitive plans and elevations on small lots.

#### CONCLUSION

Campus planning is primarily an exercise in space relations. The space arrangement of the physical structures must

satisfy not only the functions of shelter but must create an environment of containment.

The desire for physical definition needs to be satisfied in all structures and physical compositions. The planner of a campus must recognize the aesthetic needs of the individual and provide, through planning, designing and construction, the arrangement that will best provide and fulfill this aesthetic need. Space, as an entity, is one element of architectural design. Space is a primary element in campus design. Through the use of this element the campus can provide part of the necessary qualities that are inherent in all architectural design. Scale, harmony, function, unity, space and the other basic design elements must be acknowledged in the physical plant.

Campus planning must not exclude the purpose of the university. Student needs must be recognized and handled as a basic part of the entire university function. Areas and developments need to stimulate the students' learning desire and be conducive to their learning and understanding.

The final analysis and conclusions need to recognize that a campus is more than the functional arranging of buildings; it is a spatial composition based on physical desires and concluded on aesthetic needs.

**ACKNOWLEDGMENT**

The author wishes to acknowledge the invaluable assistance and counsel of Professor Emil C. Fischer, Head, Department of Architecture and Allied Arts, and Professor Murlin R. Hodgell, Department of Architecture and Allied Arts, during the various stages of this investigation and design.



## REFERENCES

## Books

1. Aronin, Jeffery Ellis.  
Climate and Architecture. New York: Reinhold Publishing Corporation, 1953.
2. Blake, Peter.  
Marcel Breuer - Architect and Designer. New York: Dodd, Meade and Company, 1955.
3. Carver, Norman F., Jr.  
Form and Space of Japanese Architecture. Translated by Ryuichi Hamaguchi. Tuttle: Skokokusha Publishing Company, 1956.
4. Church, Thomas D.  
Gardens Are For People. New York: Reinhold Publishing Corporation, 1955.
5. Eckbo, Garret.  
Landscape For Living. New York: F. W. Dodge Corporation, 1950.
6. Elements of Design. New York: Museum of Modern Art, 1952.
7. Gibberd, Frederick.  
Town Design. New York: Reinhold Publishing Corporation, 1953.
8. Giedion, Siegfried.  
A Decade of New Architecture. Zurich, Switzerland: C.I.A.M. Group, 1951.
9. \_\_\_\_\_.  
Space, Time and Architecture. Cambridge: Harvard University Press, 1952.
10. \_\_\_\_\_.  
Walter Gropius, Work and Teamwork. New York: Reinhold Publishing Corporation, 1954.

11. Gropius, Walter.  
Scope of Total Architecture. New York: Harper, 1955.
12. Haskins, Charles Homer.  
The Rise of Universities. New York: Cornell University Press, 1957.
13. Hitchcock, Henry Russell.  
In The Nature of Materials. New York: Duell, Sloan and Pearce, 1942.
14. Kimball, Sidney Fiske, and George Harold Edgell.  
A History of Architecture. New York: Harper, 1918.
15. Moholy-Nagy, Laszlo  
The New Vision. New York: Wittenborn Inc., 1947.
16. Moholy-Nagy, Sibyl.  
Native Genius in Anonymous Architecture. New York: Horizon Press Inc., 1957.
17. Neutra, Richard.  
Architecture of Social Concern. Sao Paulo, Brazil: Todtmann and Cia., 1948.
18. Papadaki, Stamo.  
Le Corbusier - Architect, Painter, Writer. New York: Reinhold Publishing Corporation, 1950.
19. \_\_\_\_\_.  
The Work of Oscar Niemeyer. New York: Reinhold Publishing Corporation, 1956.
20. Rashdall, Hastings.  
The University of Europe in the Middle Ages. Three volumes. Oxford: 1936, rev. ed.
21. Raskins, Eugene.  
Architecturally Speaking. New York: Reinhold Publishing Corporation, 1954.
22. Saarinen, Eiel.  
The City. New York: Reinhold Publishing Corporation, 1943.

23. Whittick, Arnold.  
Eric Mendelshon. London: Leonard Hill, 1956. 2nd. ed.
24. Wright, Frank Lloyd.  
An American Architecture. New York: Horizon Press,  
1955.
25. \_\_\_\_\_.  
The Future of Architecture. New York: Horizon Press,  
1953.
26. Yoshida, Tetsuro.  
The Japanese House and Garden. Translated by Marcus  
G. Sims. New York: Frederick A. Praeger, 1956.
27. Zevi, Bruno.  
Architecture As Space. New York: Horizon Press, 1957.

#### General Reference Work

28. The American Ephemeris and Nautical Almanac. Washington:  
Government Printing Office, 1958.
29. United States Department of Commerce, Weather Bureau.  
Climatological Data, National Summary, Annual 1957.  
Washington: Government Printing Office, 1958.
30. Webster's International Dictionary. 2nd edition. 1958.

#### Periodicals and Journals

31. Bloomfield, Byron C.  
"College Housing." Amer. Inst. Arch., Bul., July-  
August 1956, 10: 99-110.
32. "Can Patios Make Cities?" Architectural Forum, August  
1953, 99: 124-131.
33. Engelhardt, N. L.  
"Planning the Facilities to Meet the Educational Needs  
of Our Democracy." Amer. Inst. Arch., Journ., Septem-  
ber 1958, 30: 37-41.

34. "Environment and Building Shape." Architectural Forum,  
August 1954, 100: 105-108.
35. "How Should We Plan Our Cities?" Engineering News-Record,  
December 18, 1958, 161: 21-22.
36. Taylor, Harold.  
"The College as Client." Architectural Forum,  
June 1953, 98: 116-145.

#### Government Bulletins

37. Olgyay, Victor, and Aladar Olgyay.  
Application of Climatic Data to House Design. Housing  
and Home Finance Agency. Washington: Government  
Printing Office, 1954.

#### Unpublished Material

38. Durgan, Jack Clyde.  
An Investigation of Procedure and Techniques Involved  
in Graphic Representation. Unpublished Master's The-  
sis, Kansas State College, Manhattan, Kansas, 1958.

**APPENDIX**

PLATE I

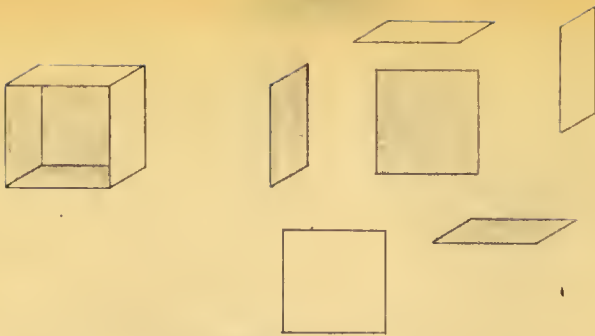


Fig. 1. Volume and scattered planes.

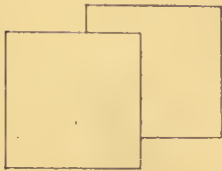


Fig. 2. Superimposed shapes.

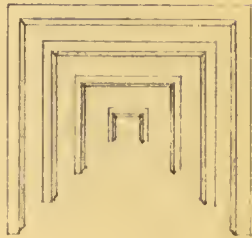


Fig. 3. Linear perspective.



Fig. 4. Light and dark.



Fig. 5. Colors.

PLATE II



Fig. 1. Limitless void.



Fig. 2. Imaginary barrier.



Fig. 3. Definite barrier.



Fig. 4. Confinement.

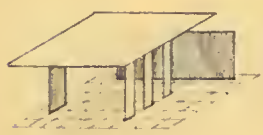
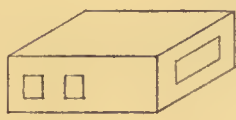
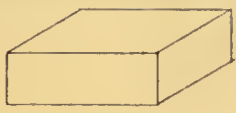


Fig. 5. Destruction of the box.

PLATE III

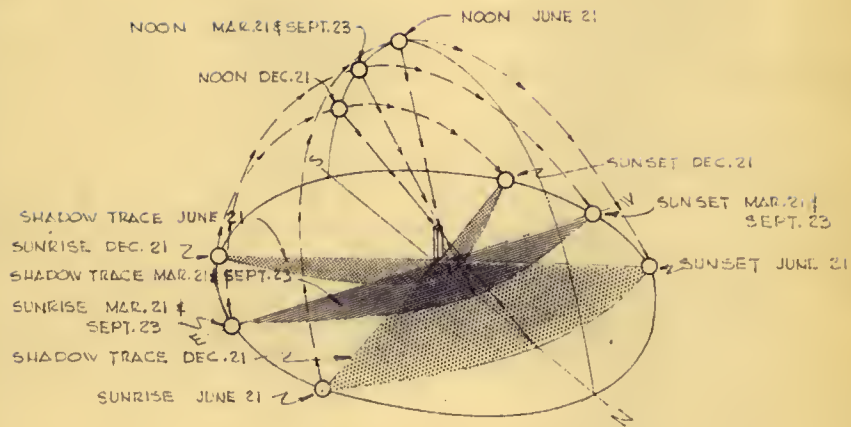




PLATE IV

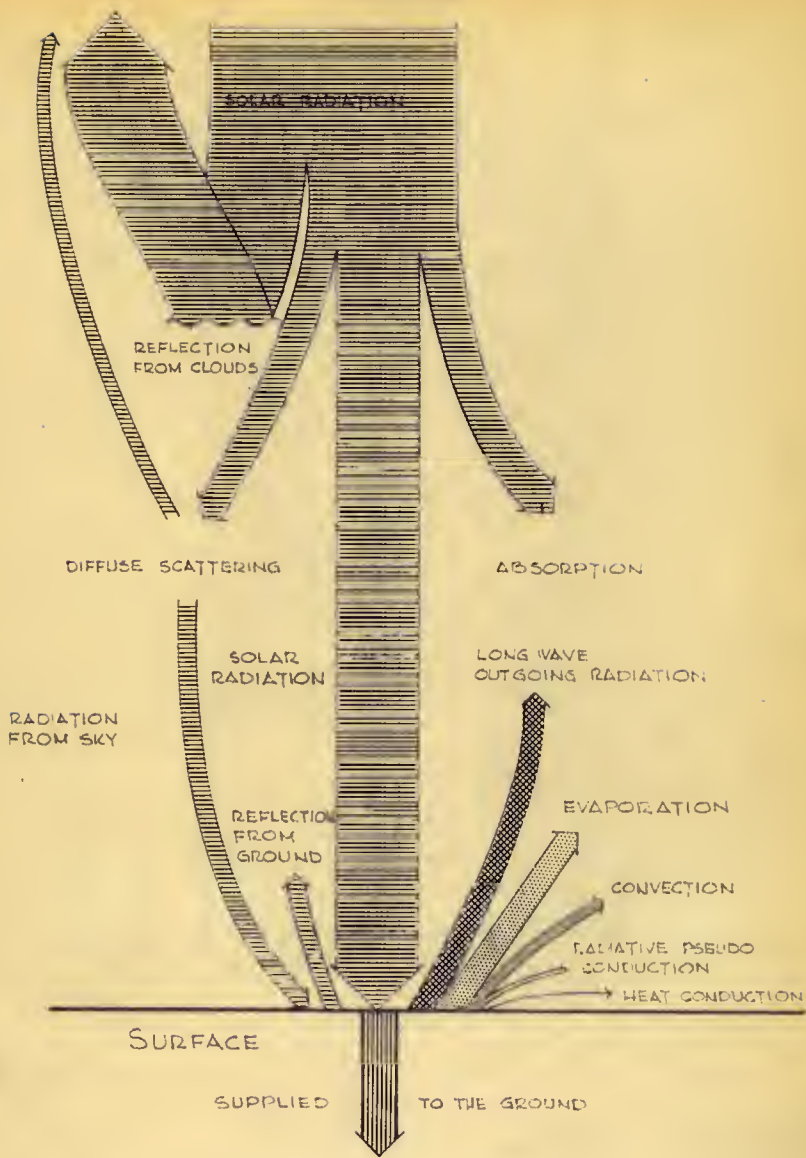


PLATE V

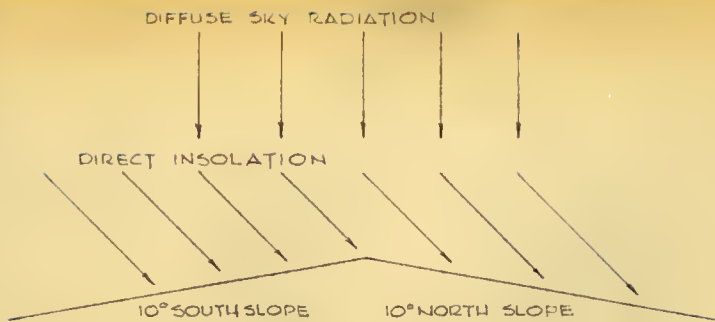


Fig. 1. Radiation and insolation effect on slope.

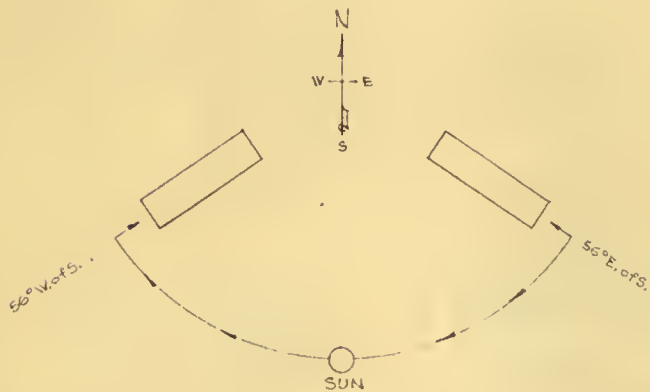


Fig. 2. Winter sweep at Wichita, Kansas.

PLATE VI

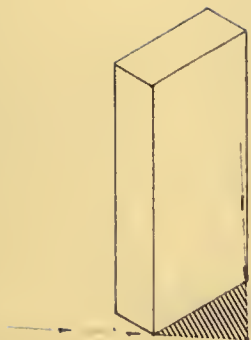


Fig. 1. Shadow triangle.

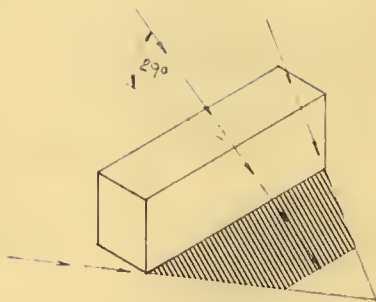


Fig. 2. Truncated triangle.

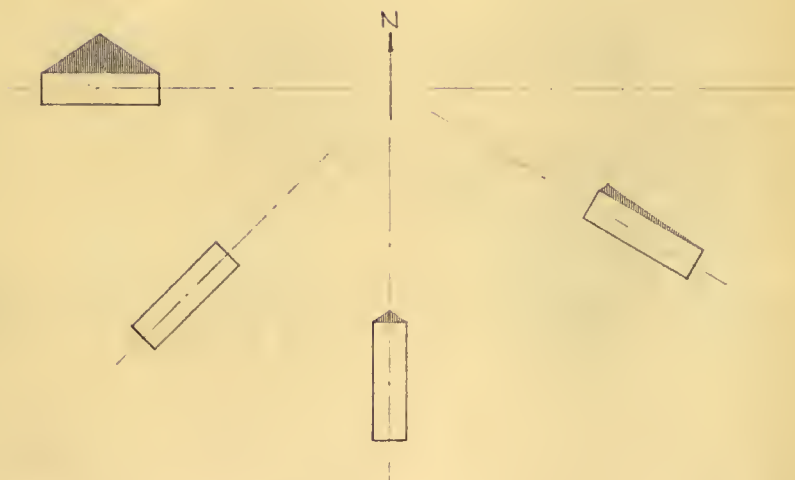


Fig. 3. Winter shadowing.

PLATE VII



Fig. 1. The "L", the "T", and the "U".



Fig. 2. The "H", and the cruciform.

PLATE VIII

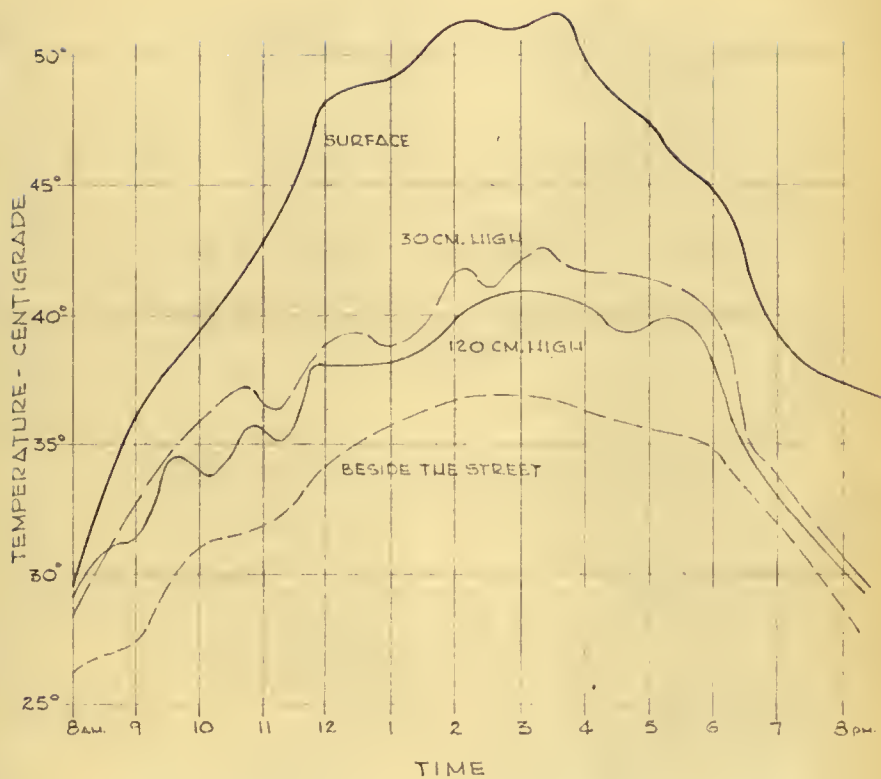


PLATE IX

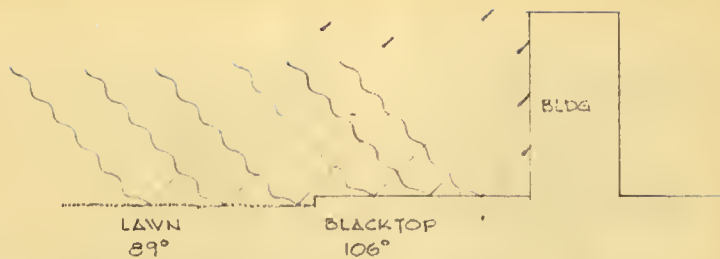


Fig. 1. Radiation of adjacent materials.



Fig. 2. Under the hypothesis that cold air behaves in the same manner as cold water.



Fig. 3. Cold air corresponding to the best observations.

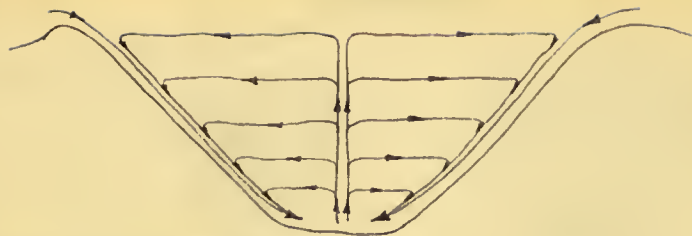


Fig. 1. Nocturnal valley winds.



Fig. 2. Wind action at a clearing.

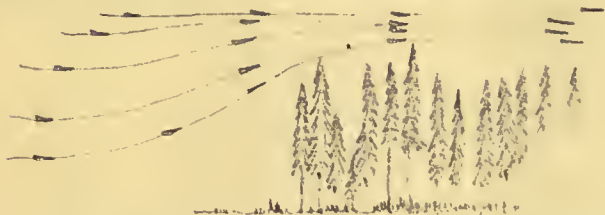


Fig. 3. Wind action at windward side of trees.

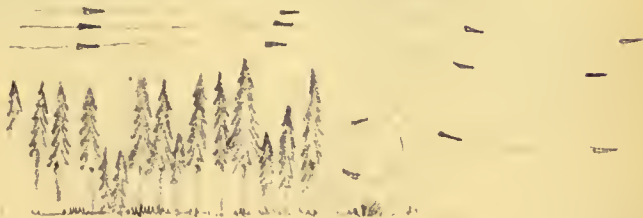


Fig. 4. Wind action at leeward side of trees.

PLATE XI

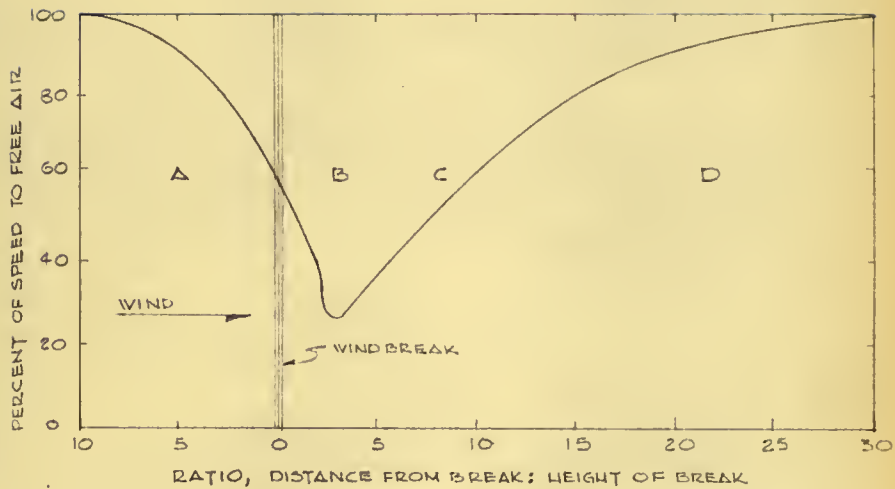




PLATE XII

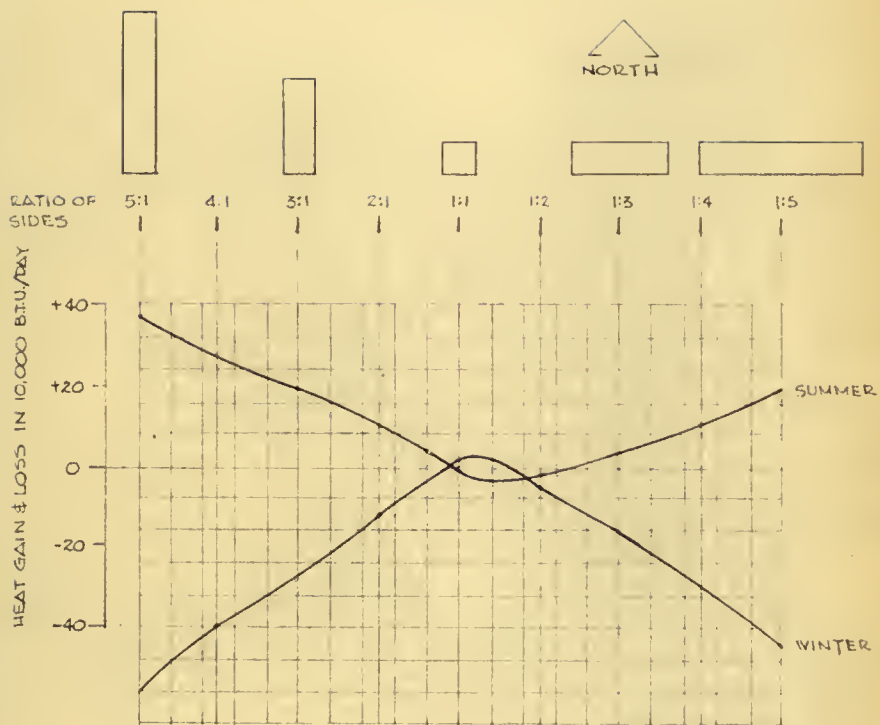


PLATE XIII

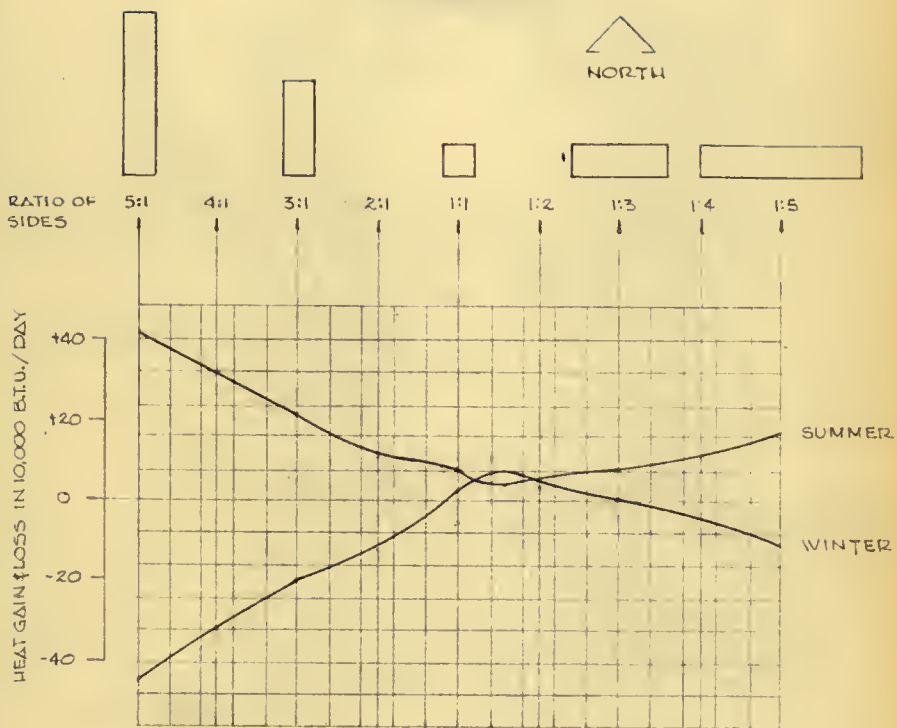


PLATE XIV

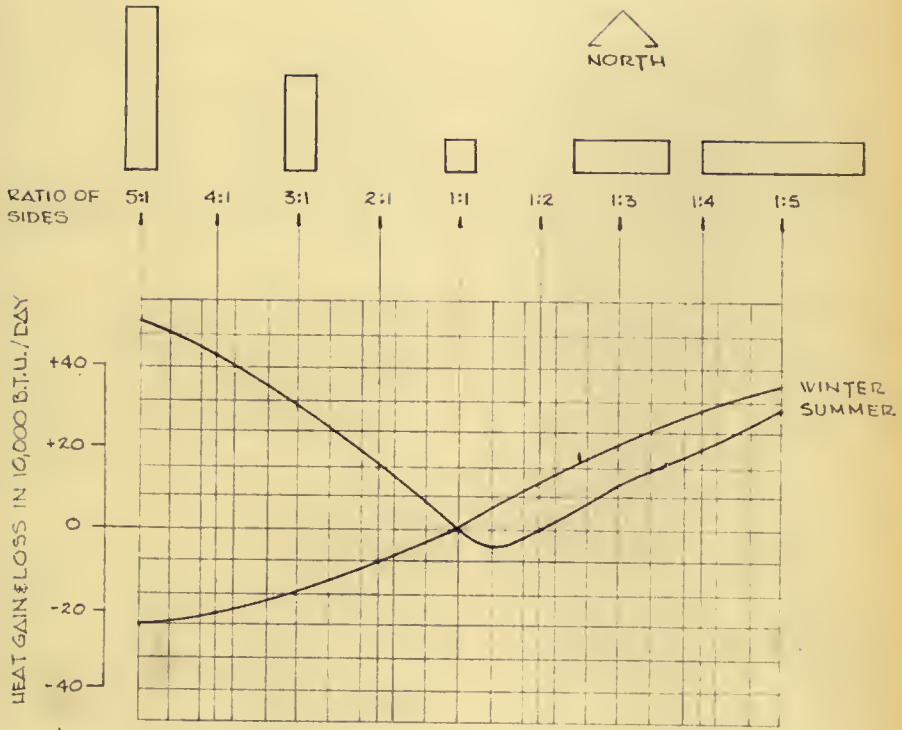


PLATE XV

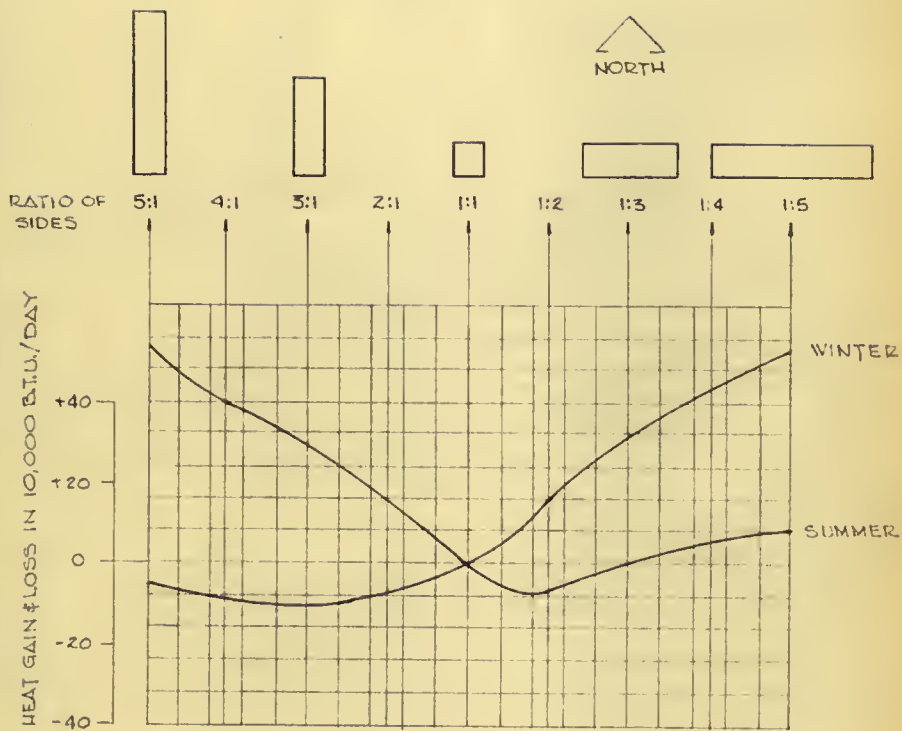
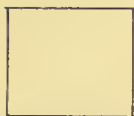
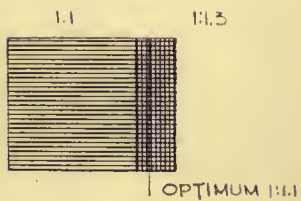
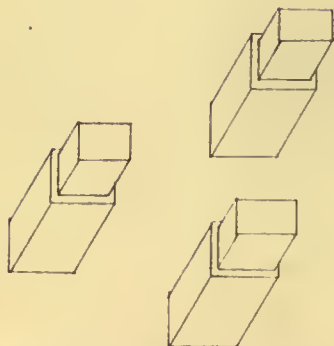


PLATE XVI

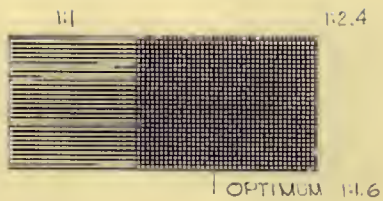


OPTIMUM SHAPE

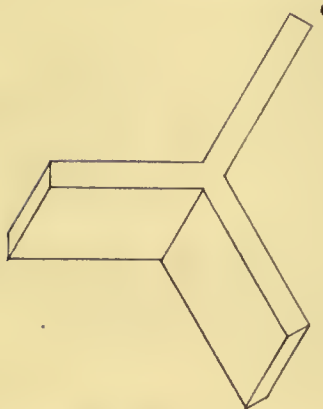


ARCHITECTURAL SHAPE

PLATE XVII

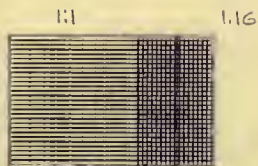


OPTIMUM SHAPE

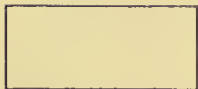


ARCHITECTUAL SHAPE

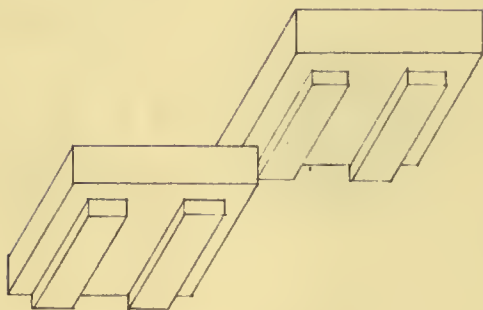
PLATE XVIII



OPTIMUM 1:13

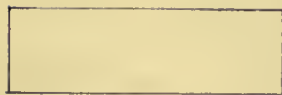
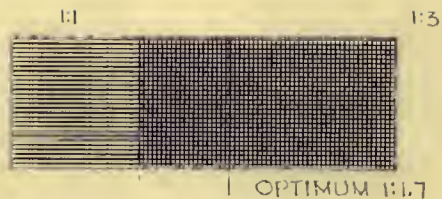


OPTIMUM SHAPE

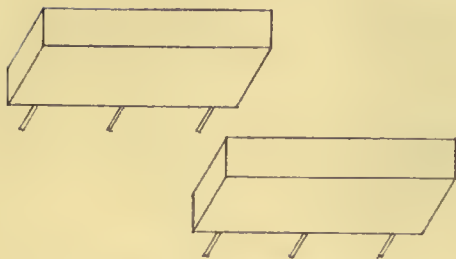


ARCHITECTURAL SHAPE

PLATE XIX



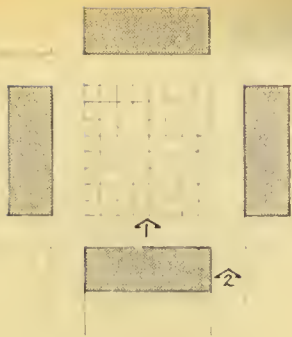
OPTIMUM SHAPE



ARCHITECTURAL SHAPE

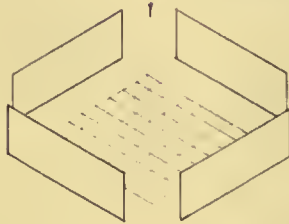


PLATE XX



FLOOR PLANE NOT TIED  
TO WALL PLANE

LOSS OF ENCLOSURE THROUGH  
THE OPEN CORNERS



SPACE BODY

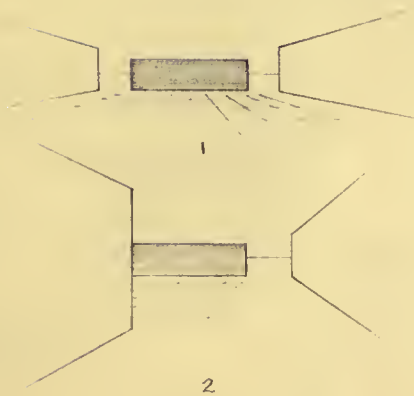
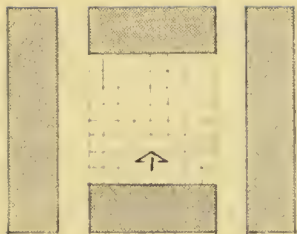
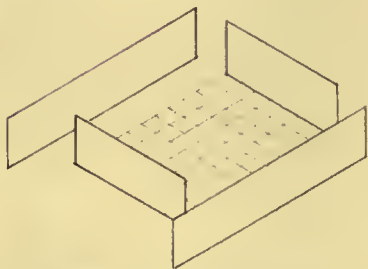


PLATE XXI



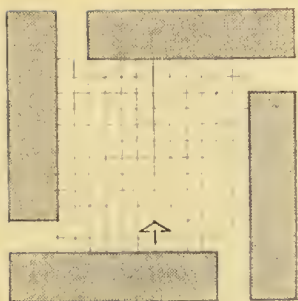
LOSS OF ENCLOSURE REDUCED BY THE  
VANISHING PERSPECTIVE  
FLOOR PLANE TIED TO WALL PLANE  
IN TWO DIRECTIONS



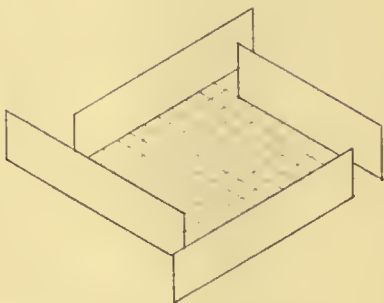
SPACE BODY



PLATE XXII



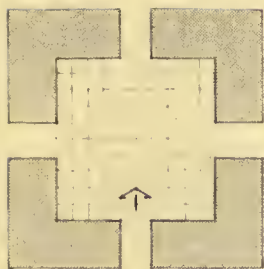
GOOD ENCLOSURE AT CORNER



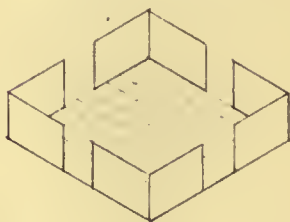
SPACE BODY



1



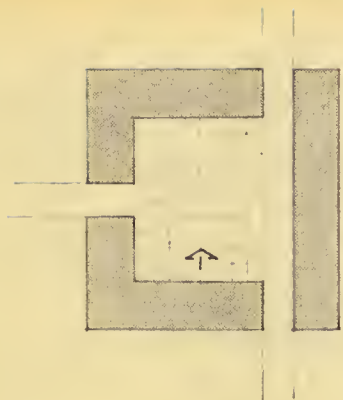
VOIDS AT NATURAL FOCAL POINTS  
NEEDS FOCAL POINT



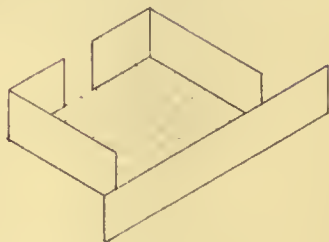
SPACE BODY



PLATE XXIV

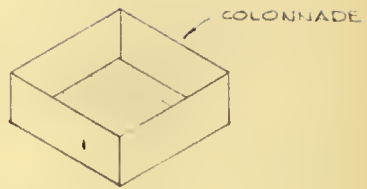
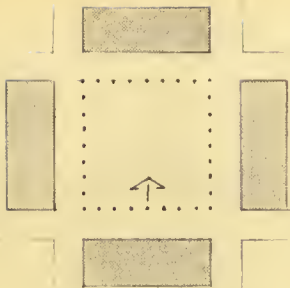


LOSS OF SPACE THROUGH OPENING  
NEEDS FOCAL POINT

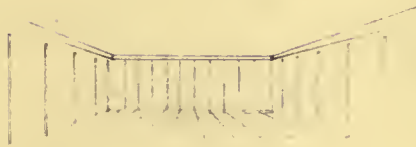


SPACE BODY





SPACE BODY



1

VISUALLY ENCLOSED



Fig. 1.  
Enclosure.

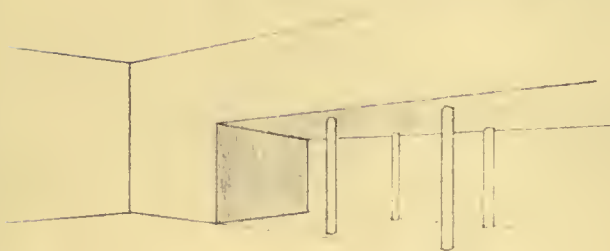
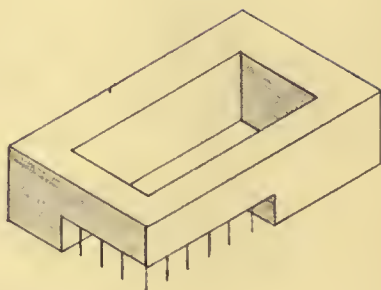
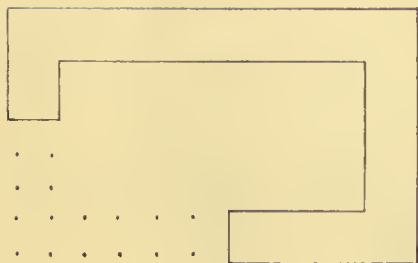


Fig. 2.  
Enclosure.



Fig. 3.  
Enclosure.

PLATE XXVI



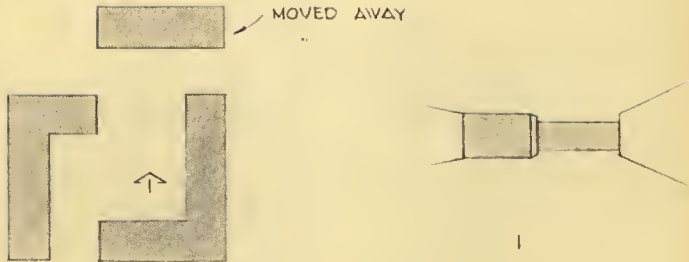


Fig. 1. Space wall.

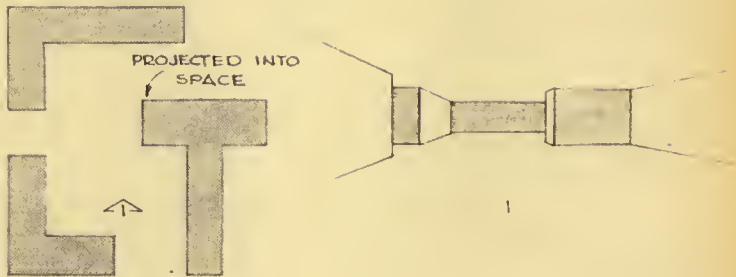


Fig. 2. Space wall.



PLATE XXVIII

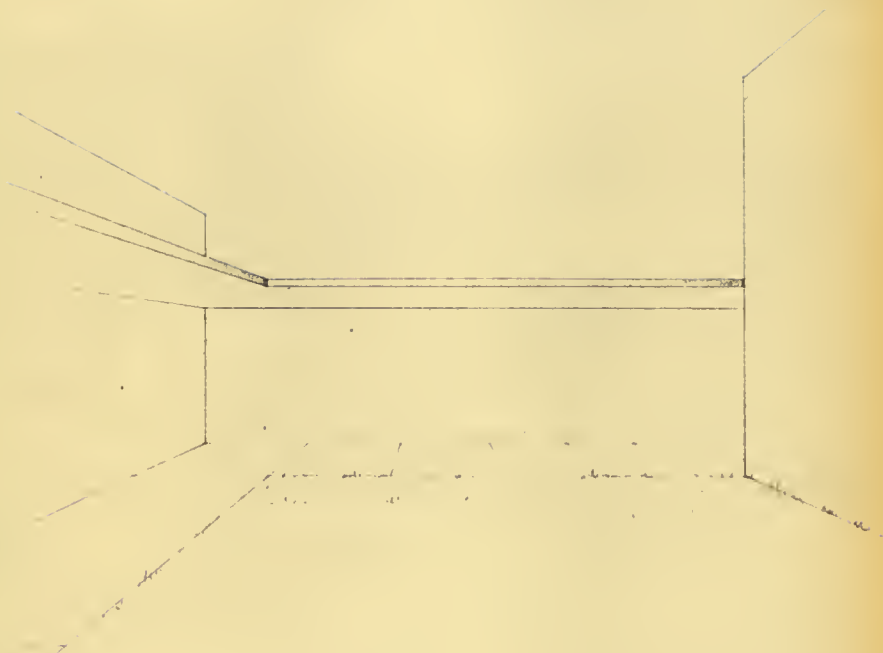


PLATE XXIX



Fig. 1. Axial vista.

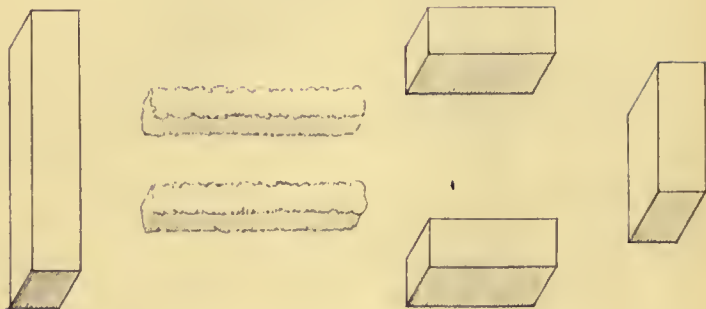


Fig. 2. Axial vista.

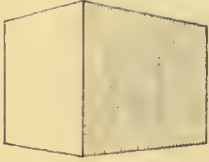


Fig. 1. Mass.

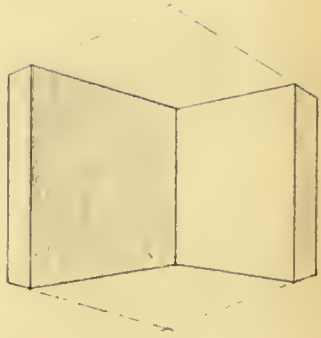


Fig. 2. Volume.

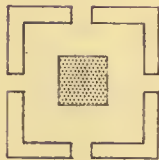


Fig. 3. Plastic mass in space.



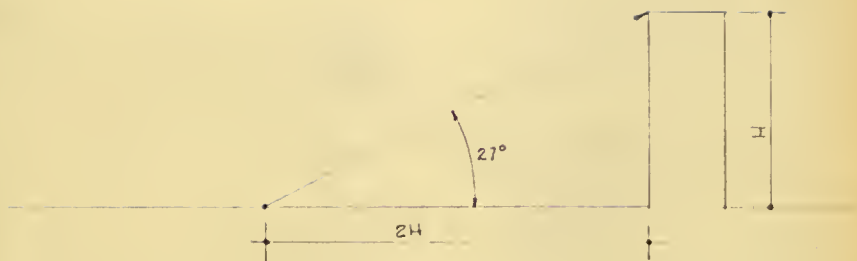


Fig. 1. Distance-height ratio to see an entire building.

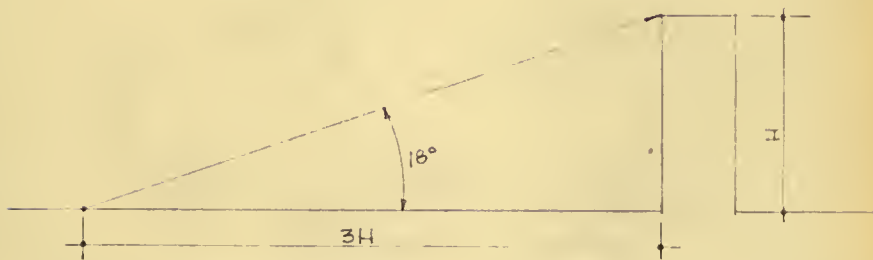


Fig. 2. Distance-height ratio to see an entire group of buildings.

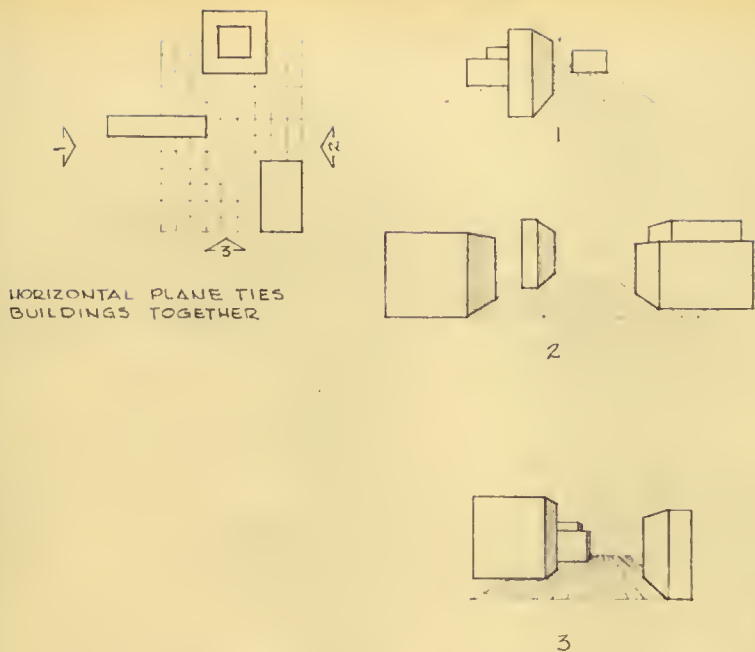


Fig. 1. Related in space.

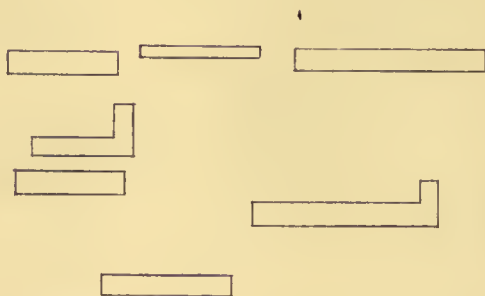


Fig. 2. Parallel with right angles.

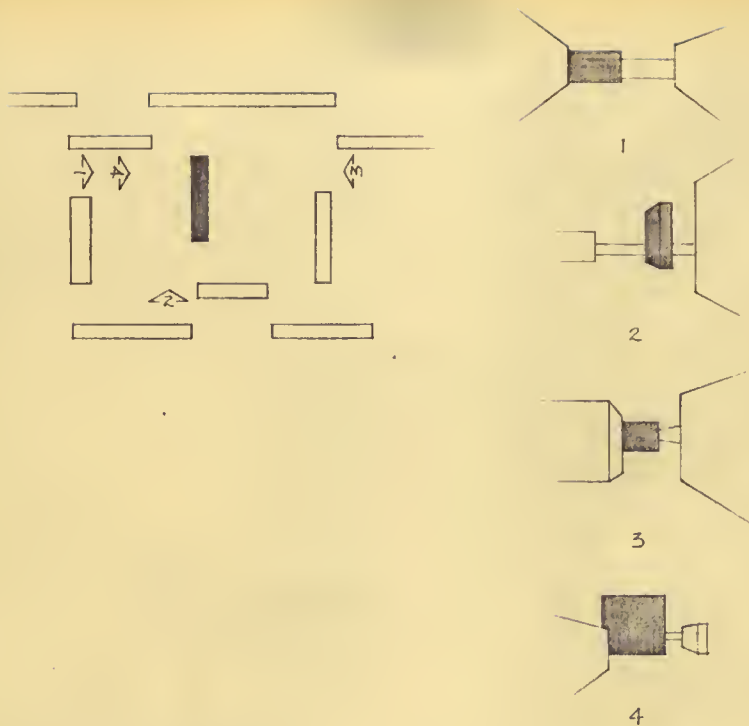


Fig. 1. Correlation.

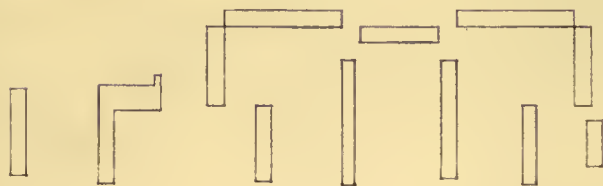


Fig. 2. "L's".

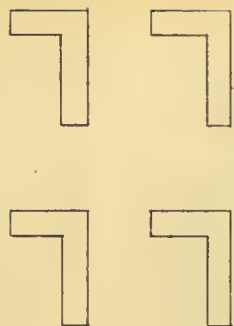


Fig. 1. "L".

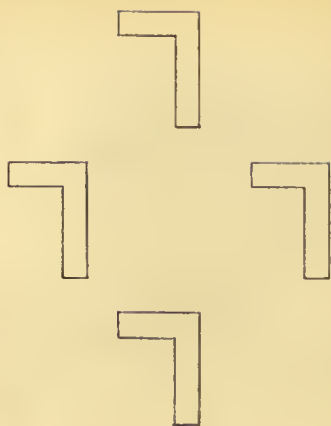


Fig. 2. "L".

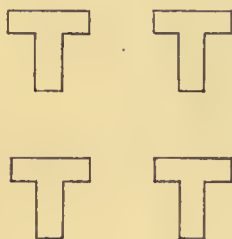


Fig. 3. "T".

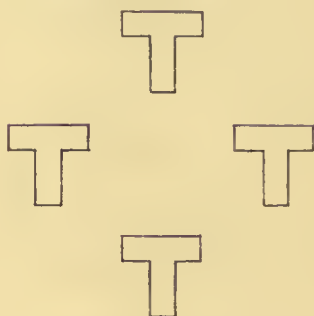


Fig. 4. "T".

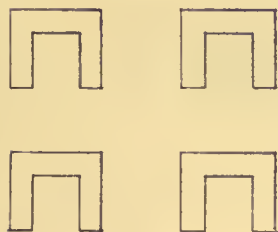


Fig. 5. "U".





Fig. 1. Cruciform.

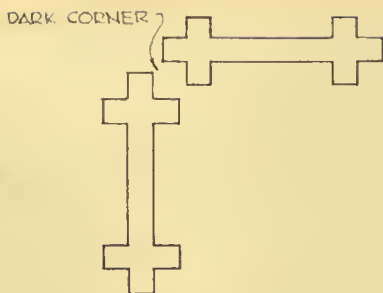


Fig. 2. Cruciform.

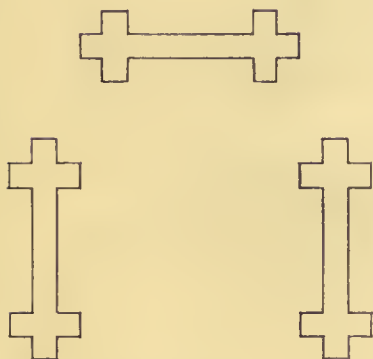


Fig. 3. Dissociated.

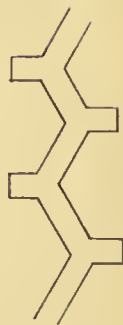


Fig. 4. Space wall.



Fig. 5. Hexagonal.

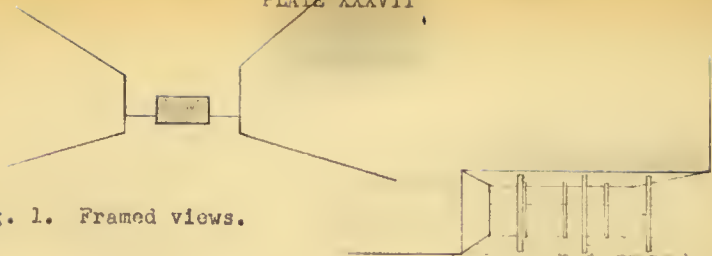


Fig. 1. Framed views.

Fig. 2. Pierced.

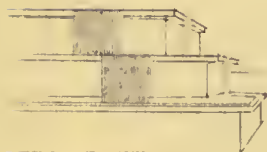


Fig. 3. Varied levels.

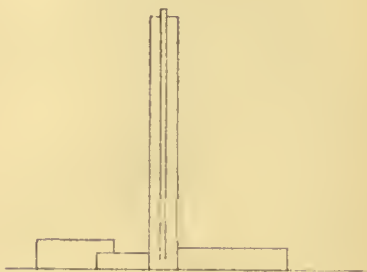


Fig. 4. Plastic body.

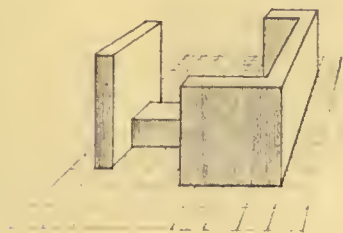


Fig. 5. Space body.



Fig. 6. Plastic mass.



XLIX

XLVII

XLVI

LI

LII

XLVIII

XLII

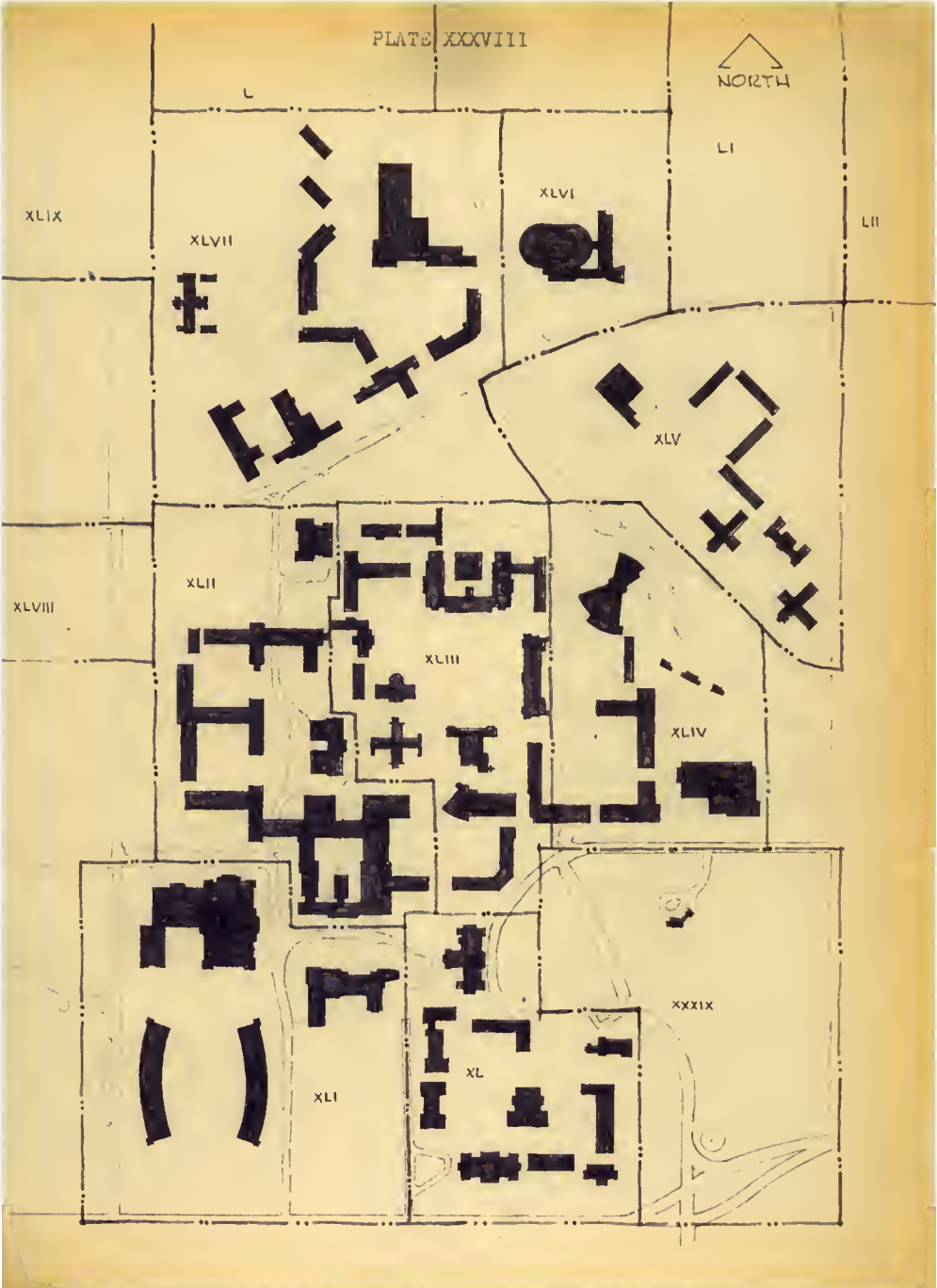
XLIII

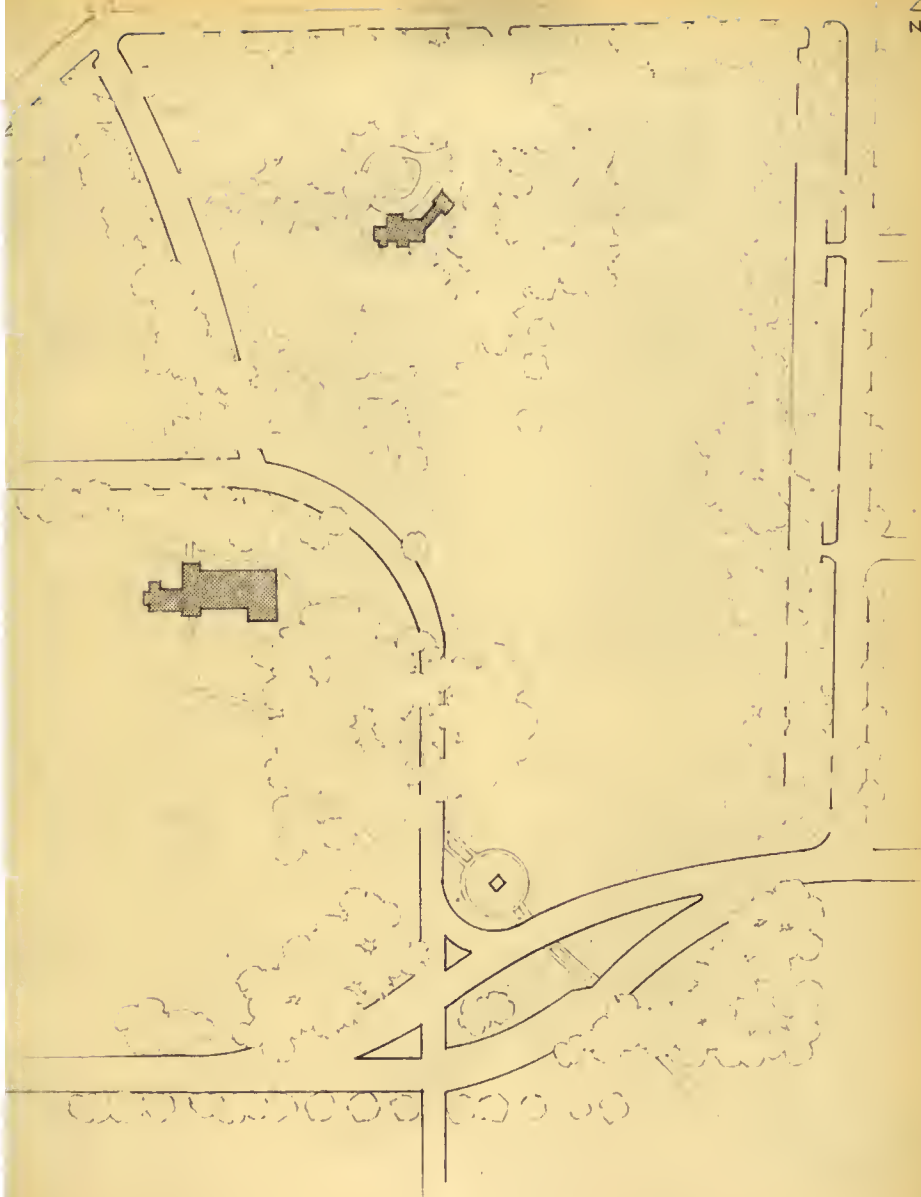
XLIV

XXXIX

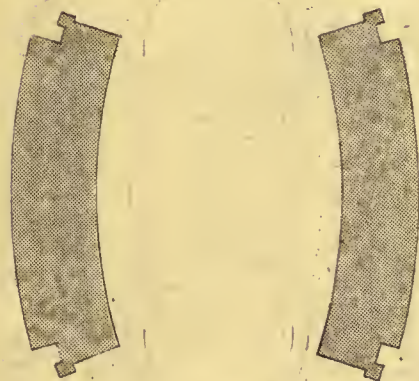
XLI

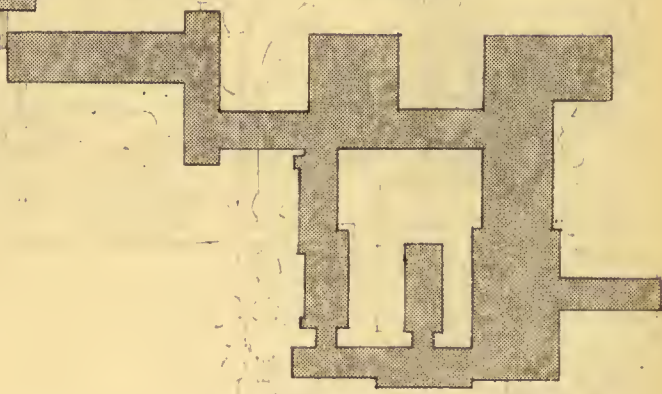
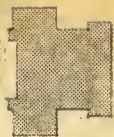
XL

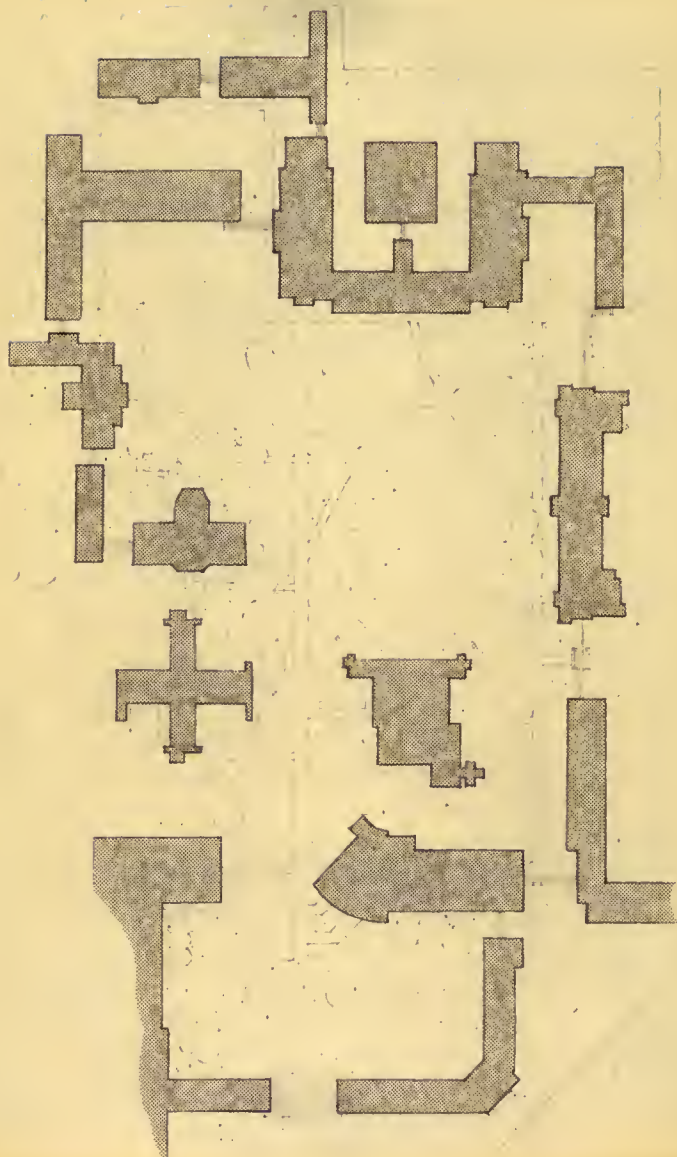




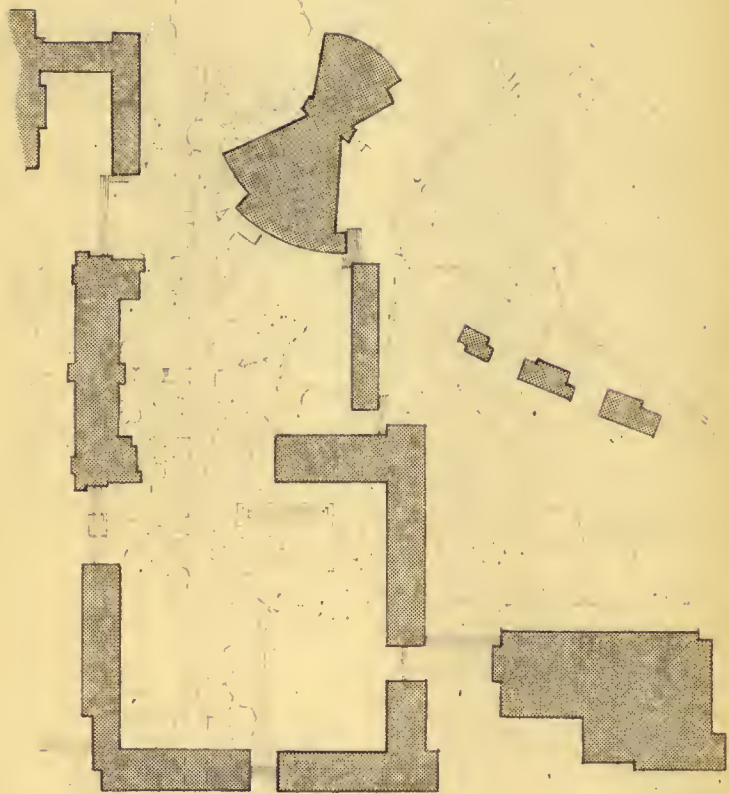




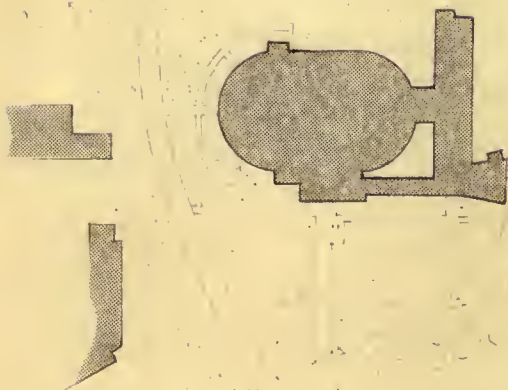


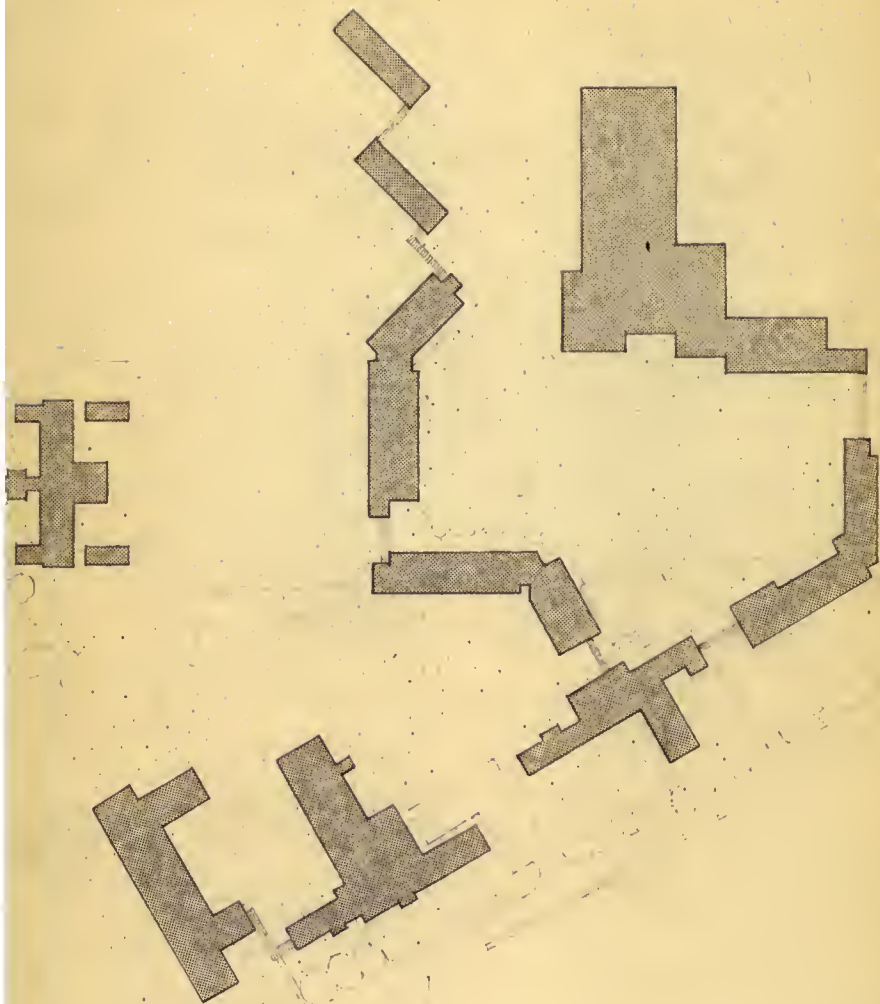




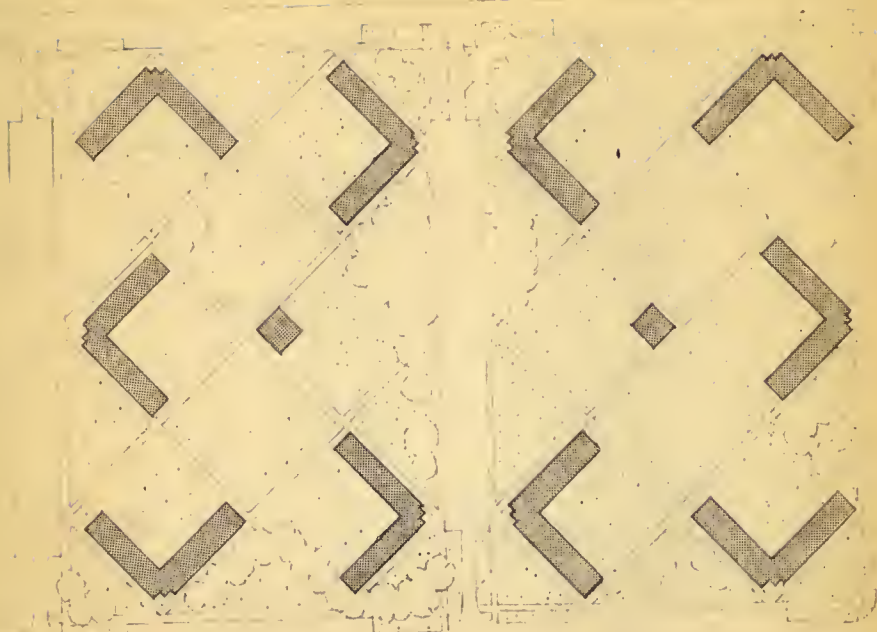




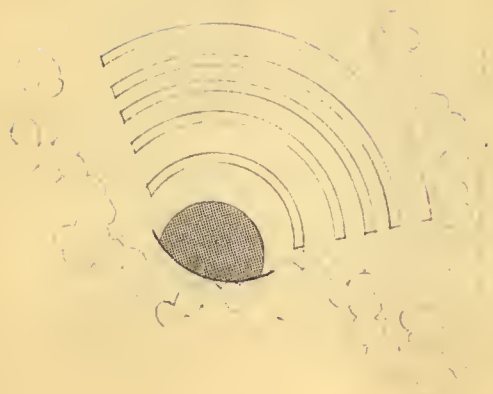
















DESIGN OF A UNIVERSITY CAMPUS

by

HOMER LEROY PUDERBAUGH

B. Arch., Kansas State College of  
Agriculture and Applied Science, 1952

---

AN ABSTRACT OF A THESIS

submitted in partial fulfillment of the

requirements for the degree

MASTER OF SCIENCE

Department of Architecture

KANSAS STATE UNIVERSITY  
OF AGRICULTURE AND APPLIED SCIENCE

1959

The purpose of this thesis is two-fold. First, to establish a basis for space relationships between buildings and building groups as a criteria of design, and second, to show how this criterion is resolved into an actual physical creation based on space recognition and its relations to other design elements.

Building group design and campus planning involve the arrangement of buildings into groups and the composition of groups into a final unity based on complementary and occasionally conflicting factors. While there are many considerations in the final building location, the recognition of function, orientation, and inter-relationships through space-time considerations must be initiated during the preliminary studies and maintained throughout the entire design stages if the final product is to be successful.

Administrative decisions must be made and basic educational philosophies determined. A goal must be established and limits of operation set. Within this framework planners must be free to consider and decide the many aspects and problems which are to be solved. They must use the established administrative policies and goals as the end toward which they are working. They must have available the latest statistics on densities, enrollments, sex ratios, marital status and finances, and

must recognize social pressures and education trends. Such factors as orientation, sequence of construction, building funds, available (present and future) land space, and inter-college functions are to be considered within the wider scope of the end results and the operational policies. Decisions, with alternatives, must be at least ten years ahead, and generalities should be projected twenty years into the future.

Space is the basis for all relationships between buildings in a group and between groups in a composition. While there are many elements and considerations in campus design, the functions of the other elements are related through spatial considerations. It is not denied that all the other elements of good design contribute heavily to the success or failure of the architectural design, but their relations are functions of space and time and as such are subordinated to space-time theories. Space is an integral part of any physical creation, regardless of the value judgment used. Any reference to other design elements, whether it is to scale, harmony, unity, duality, monotony, proportion, repetition, etc., cannot be made without crediting the space between, around, or through the design, for it is this space that gives definition to all the others.

Space, then is the criterion for campus planning. Streets, pedestrian walks and building locations must measure the distances, the widths, the heights and the depths of the enveloping space. Single story or multi-story structures, enclosures, quadrangles, facades and open areas are determined on a statistical-need basis, but are located on a space-time basis. The final analysis and conclusions need to be based on a recognition that a campus is more than the functional arranging of buildings. It is a composition based on physical desires and concluded on aesthetic needs.