

USER PREFERENCE EVALUATIONS  
OF DIFFERENT CONFIGURATIONS OF AN  
ELECTRONIC HORIZONTAL SITUATION INDICATOR

by

Mark D. Reiff

B.S., IOWA STATE UNIVERSITY, 1985

---

A REPORT

submitted in partial fulfillment of the

requirements for the degree

MASTER OF SCIENCE

Psychology

Kansas State University  
Manhattan, Kansas

1988

Approved by:



Major Professor

L.D.  
2668  
R4  
PSYH  
1988  
K44  
c 2

A11207 312116

Work is currently being done at Kansas State University toward the development of an Electronic Horizontal Situation Indicator (EHSI) proposed by Stephen Dyer (1982) for use in general-aviation aircraft. Comprising part of an aircraft's instrumentation, an EHSI is a digital avionics system which utilizes a computer-generated cathode-ray tube (CRT) display. The EHSI depicts to the pilot the aircraft's position relative to known radio navigation fixes using a pictorial representation.

A major goal of the proposed EHSI is to reduce the mental workload of the individual pilot, particularly when operating under instrument-flight-rules (IFR) conditions. Because pilot workload is greatest under IFR conditions (Kershner, 1969), it is important that the EHSI present the necessary flight information in a fashion that can be interpreted quickly and easily with minimum ambiguity, so that the pilot can correct his or her flight path. Exactly how this information should be displayed so that this goal can be met is not clear. The present study was designed to investigate important display characteristics that are necessary in a successful display by evaluating specific displays that

differ in their method of presentation, using the opinions of a sample of experts (i.e., pilots). The resulting data were analyzed and interpreted to provide a summary of the pilots' opinions which can be used by those who are responsible for the continuing development of the EHSI.

Recently developed digital avionics such as the EHSI provide numerous display possibilities. Any information that is available to the EHSI can be displayed to the pilot in a variety of ways.

Although digital avionics systems have already been developed for larger passenger airliners such as the Boeing 757 and the Airbus A310 (Lerner, 1983), no similar system exists for smaller, less expensive aircraft. Although such a system can now be developed, size and cost restrictions impose limitations on the proposed system that prevent patterning it directly after those found on larger aircraft.

In his thesis describing his role in developing the present EHSI, Lagerberg (1987) pointed out that much of the information required in producing the existing digital avionics displays is not available on a small aircraft. An EHSI for small aircraft must be able to acquire the necessary flight information from navigational radios and other available sensors. Thus, the development process for the proposed system has

necessitated the breaking of new ground. Little relevant research is available.

The purpose of the present EHSI, as described by Lagerberg, is to simplify the task of assimilating all the available information that a pilot must use during the course of a flight. Such a system will be particularly well received by pilots having to fly in IFR conditions. IFR conditions are said to exist when weather conditions deteriorate below certain minimums specified by the Federal Aviation Administration (FAA). Under such conditions, usual navigation utilizing prominent landmarks is not possible. When flying under IFR conditions, the pilot must abandon his or her sense of visual flight and navigate solely by the use of available instruments. Flying under IFR conditions results in a much greater workload for the pilot.

The available techniques that allow the IFR pilot to establish his or her position can be classified as radio navigation. A system of ground-based radiowave transmitters with known locations allows a pilot to locate his or her positional "fix" by using any two of the radio facilities in conjunction with the other available instruments. The present EHSI will simplify this task by presenting a pictorial representation of the aircraft's horizontal position relative to the two different radiowave transmitters. A vertical fix above

the ground is obtained using pertinent data gathered from other sensors, such as the altimeter.

The EHSI in present form provides the pilot with three different display pages of information which are displayed on a vector graphics display (VGD).

Robertson (1987) described in his thesis the three different page functions that are available on the EHSI:

- 1) FLIGHT DATA PAGE: This page contains such information as the plane's heading, airspeed, present altitude, assigned altitude, minimum descent altitude (MDA) or decision height (DH), navigational frequencies, communication frequencies, automatic direction finder (ADF) frequency, way points, current time, temperature, etc.
  
- 2) NAVIGATIONAL PAGE: This page provides the pilot with information about the plane's heading in a compass-type format, position information with regard to known navigational fixes such as VHF Omnidirectional Range/Tactical Air

Navigation systems (VORTACs) and non-directional beacons (NDBs), present altitude, airspeed, etc.

3) INSTRUMENT LANDING SYSTEM (ILS) PAGE:

This page provides information about a plane's position on an ILS approach. It contains the plane's position relative to the glideslope and localizer and displays it in a useful format to allow the pilot to do an instrument landing. Heading, altitude, MDA/DH, and marker status will also be displayed.

As of May, 1987, development of prototype displays for the flight data page and the navigational page was essentially complete. The information included in the flight data page is presented in a digital format using alphanumeric characters. It provides simple digital readout values allowing easy reference and interpretation. Unlike the flight data page, the navigational page uses an analog format to present information about the plane's heading and position

relative to navigational fixes. This simple display allows quick interpretation of the plane's horizontal position and heading. The display format is very similar to, and consistent with, comparable instruments offered by the Sperry, King and Rockwell/Collins companies.

Development of the ILS page has not progressed as far as the other two display pages. The ILS page will see continuing development throughout the coming year. As Robertson mentioned, the ILS page will be the most complicated and time-consuming to develop. When completed, the ILS page will offer the most complex display of the three different pages.

Questions to be answered before the ILS display is completed concern how the information should be displayed and what it should look like. Unfortunately, answers to these questions are not readily available, leaving the task of designing the display both difficult and ambiguous. The final pictorial display, however, must present enough information so that the plane's position and trend are communicated without becoming too cluttered and complex. How this will be accomplished is not clear.

The use of visual pictorial codes is not new. The potential advantages gained from the use of pictorial displays in aircraft were the focus of an earlier paper

by Carel (1965). Potential advantages described by Carel include quicker pilot assimilation of qualitative information from pictorial displays, and pilot accumulation of information on more than one parameter per glance. Thus, pictorial displays can selectively display more information with less clutter than is possible with other display formats. Until recently, however, the technology necessary to present flight information pictorially has been lacking. An excellent definition of what is meant by "pictorial," as it applies to visual pictorial codes, is that such codes are ways of showing the relations between a great many variables in a common frame of reference by the topology of the elements displayed (Roscoe, 1968).

When designing pictorial codes for use in aviation, the goal is the creation of the appropriate microcosm in the cockpit. An objective in designing such a code is to represent the environmental events so that little or no misinterpretation of the environment dynamics will be made by the observer. Thus, "pictorial" means a one-to-one correspondence between the display and reference domains with no differential transformations along a given axis. Because such codes are based on highly developed population stereotypes, Carel suggested that pictorial codes are easily learned, provide operational flexibility, and enhance



failure or error detection and diagnosis.

While there is consensus on the potential advantages of pictorial displays, there is little or no agreement as to how the relevant flight data should be displayed. Roscoe (1968) noted that while everyone agrees on what information should be displayed, few agree as to how it should be presented. This is not to say, however, that there are no guidelines or general principles that can be used in designing a pictorial display.

Indeed, relevant human factors research has delineated certain performance parameters that should be maintained for optimal visibility of a CRT display. Research (Kantowitz & Sorkin, 1983) indicates that the minimum refresh rate (rate of screen regeneration) of a CRT generated picture should be 45 hz. The recommended refresh rate is at least 60 hz. Depending on observer viewing conditions, a display flicker may be visible between 45 hz and 60 hz. The picture may appear dimmer than usual or will oscillate visibly in brightness.

Kantowitz & Sorkin's (1983) research also suggests that the vectors that make up a CRT-generated picture should maintain certain approximate width-vs-height ratios for maximum visibility and discrimination. Such ratios should be maintained when generating vectors as well as when generating alphanumeric characters.

The digital display module being used here at KSU for this project is the 1345A, manufactured by Hewlett-Packard. The 1345A is a programmable high-resolution display with a screen diameter measuring 15.24 cm (6 in.) with a maximum capability of 2048 x 2048 addressable points. The 1345A draws vectors at one of four writing speeds, which assures lines of uniform brightness, highlighted areas or light graticules (producing a texture gradient). The 1345A has a built-in set of alphanumeric characters for identification of picture elements. The characters have been prespecified in accordance with previously cited research (Kantowitz & Sorkin, 1983), which has demonstrated the desired optimal width-vs-height ratios to be utilized in such a display.

Kantowitz & Sorkin (1983) noted two necessary properties of an effective display that go beyond the visibility considerations discussed previously. An effective display will generally have the following properties: (1) distinguishability between all parts and symbols of a visual display; and (2) interpretability of all display variations into appropriate actions.

Display distinguishability can be enhanced through the use of differential contrast and texture gradients that provide depth and distance cues. This can be

facilitated further through the use of linear perspective techniques that minimize symbol confusion and maximize symbol motion-detection (Roscoe & Williges, 1975). Display interpretability has been maximized by using numerical codes and broad-range scales where appropriate (Kantowitz & Sorkin, 1983).

Indeed, previous research (Carel, 1965; Johnson & Roscoe, 1972; Roscoe, 1968; Roscoe & Williges, 1975) indicates that certain symbol relationships and display principles should be utilized for optimal pilot performance. Unfortunately, there is a surprising lack of research investigating how the various relationships and principles should be displayed. Research in this area might be stimulated with the recent availability of digital technologies that allow greater flexibility in designing displays.

One purpose of the proposed study was to investigate pilots' preferences among variations of three different pictorial display designs that have been proposed by Dyer (1982), Lagerberg (1987), and Robertson (1987). The three different designs all maintain the same motion relationships and basic symbol representations suggested in previous research.

The designs differ in topology, however, in that various levels of complexity have been used to display the relevant positional and trend information. While

the same information has been displayed, the different levels of complexity used to display the information may lead to increased clutter, which may hinder the ability of the pilot to assimilate the data.

This study attempted to discover which display format is preferred by pilots, and for what reasons. This study also addressed the concern expressed by Lagerberg (1987) that constant evaluation of the prototype and its development be carried out. More specifically, Lagerberg felt that care should be taken not to make the display too complex, which would defeat its purpose of reduced mental workload.

Lagerberg suggested that such evaluation should be carried out through the use of qualified IFR-rated pilots. This use of "experts," or "users," to evaluate the design progress is quite intuitive and forms the industry standard of using pilots in aircraft design. Carel (1965) noted that in actual avionics systems work, the choice of display design characteristics often depends not on formal analysis but on:

- 1) Familiarity with the system. With few exceptions, pilots and ex-pilots make the most significant contributions to the design of aircraft instrument displays.

- 2) Panel space.
  
- 3) Engineering feasibility and available hardware.
  
- 4) User acceptance.

Carel further noted that such design is usually followed up by iterative evaluations in the form of paper simulations, flight simulations, or test flights.

The present study used a sample of both IFR- and visual flight rules (VFR)-rated pilots to evaluate three different simulated display designs. The displays were simulated on paper to closely represent what the pilot would actually see. Each different display was presented as a series of two displays, demonstrating to the pilot how the display will change as the aircraft moves toward the target. Thus, it is felt that a great deal of realism and "feel" was retained in the simulation. Paper simulation was chosen because it is highly feasible. To use a flight simulator, each proposed display must be programmed into the computer. Robertson (1987) indicated (personal communication) that this would consume more time and energy than is available.

The group of VFR-rated pilots was included for two reasons. As Robertson (1987) pointed out, a major potential use of the EHSI system is to train IFR pilots. Thus, it may be important if IFR and VFR pilots evaluate the displays differently. On the other hand, if both pilot groups express the same preferences, that would support the robustness of any such effect.

The involvement of experts or users in system design is accepted as a necessary component when designing or improving any pilot system (Cooper, 1957; McDonnell 1969;) or any other expert system (Hofer, 1985; Newman, 1984; Olson & Ives, 1981). In the process of evaluating the suitability of a pilot system, McDonnell pointed out that it is necessary to solicit pilots' comments and opinions concerning the system's qualities as one facet of the investigation. McDonnell further emphasized that subjective opinion is, in fact, part of the ultimate evaluation of the system, and should therefore be considered seriously and continuously throughout the system design.

Empirical research by Olson and Ives (1981) indicated that user involvement in system design correlates positively with both system usage and user satisfaction with the system. Thus, Olson and Ives strongly suggested that user involvement in system

design become standard practice during the development process. This helps to ensure that the newly developed system will, in fact, meet user needs and desires. Thus, the impetus for using pilots in this study stems from both the documented use of experts in system design and from intuition.

#### METHOD

The data were collected from the pilots using questionnaires and interviews. Because of the potentially confusing nature of the simulated displays, having an interviewer present minimized possible misinterpretations or improper scoring. An interviewer was present to offer any necessary explanations to the subjects, and to ask additional relevant questions that may facilitate the evaluation.

#### Subjects

Subjects for this study were 20 IFR- and 10 VFR-rated male pilots living in the Midwestern United States during October of 1987. The pilots were recruited during personal visits to several airfields in the Midwest.

The subjects were told that their participation was voluntary, that the data would be anonymous, and that they could withdraw at any time. The subjects

were briefed using a written statement of the purpose of the research, followed by a brief oral statement.

### Procedures

Each of the 30 subjects evaluated all three sets of display designs. Each display design was presented as a series of two displays which illustrated how a particular display design would appear as a function of distance, height, and approach-angle changes. Thus, it was expected that the use of a display set would maximize interpretability and minimize ambiguity.

The three display designs differed primarily in the level of complexity and display screen area used to create the pictorial display. The three levels corresponding to low, medium, and high complexity were labelled A, B, and C (Appendices C-1, C-2, and C-3, respectively). The subjects independently compared two designs at one time in a forced-choice paradigm, ultimately comparing all possible pairs. This design has the advantage of lending itself to immediate internal consistency and reliability evaluations due to an expectation of transitivity in the pilots' choices among the various pairs (Nunnally, 1979). The presentation of the display designs was counterbalanced in that "groups" of 10 pilots, consisting of similar proportions of IFR and VFR pilots, received one of



three different presentation orders of the display pairs: A and B, B and C, and A and C. The three different presentation orders used were: AB, BC, AC; BC, AC, AB; and AC, AB, BC. The three presentation orders that were not used were: AB, AC, BC; BC, AB, AC; and AC, AB, BC. When presenting each display pair, both displays were presented at the same time.

The subjects responded using a short, structured questionnaire prepared by this researcher. A short interview followed, directed at determining what factors were used by the subjects to make their decisions.

After a pilot volunteered to participate, the pilot was escorted to a suitable location, usually a vacant room or pilot lounge that was free of observers who might participate at a later time. Thus, all data were collected individually and independently.

The subject was then given the introductory statement which described the purpose of the study, provided general information, and guaranteed anonymity (Appendix A). After the subject read the statement, this interviewer reiterated the basic procedure and clarified any potential existing confusion. Written consent was collected at this time.

The subject was then shown two of the display sets, and allowed time (2-3 minutes) to assimilate and

compare them. Once the subject felt sure that they understood the displays, they were asked to respond to the questionnaire (Appendix B). This was repeated two more times, allowing for all the comparisons to be made. Follow-up questions were asked and comments solicited, when appropriate, to better understand any peculiarities (i.e., intransitivity). Finally, subjects were thanked for their participation.

The introductory statement, the questionnaire, and the display sets are located in the appendix.

### Measures

The questionnaire was designed to determine which display is preferred by which set of pilots (IFR or VFR), and why. The questionnaire asked for pairwise comparisons among each of the three display designs on each of four criteria corresponding to glideslope, localizer, clutter, trend correction, and two personal-use-preference criteria. Depending on the resulting responses to the questionnaire, various additional questions were asked during the interview to more fully understand the decision process. Comments and suggestions were also solicited from the sample to facilitate possible improvement in the display design.

Finally, demographic information was obtained at the conclusion of the interview. That information

included the pilots' (1) total hours flown, (2) number of ratings (pilot qualifications) held, and (3) number of years as a pilot.

The responses to each questionnaire were analyzed using the sign test (Daniel, 1978; Seigel, 1953). This method converts the responses to either a plus or a minus sign rather than a quantitative measure. This test is particularly useful for research in which quantitative measurement is impossible or unfeasible, but where it is possible to rank the two members of each pair with respect to each other.

The only assumptions underlying this test are that the variable of interest is measured on at least an ordinal scale, and that it is continuous in nature. The test does not make any assumptions about the form of the distribution of differences, nor does it assume that all subjects are drawn from the same population. The only requirement is, that within each pair, the experimenter has achieved matching with respect to the relevant extraneous variables. This was accomplished by using each subject as his own control.

Because there was an expectation of transitivity in the pilots' choices among the various pairs, performing a sign test on each pair automatically resulted in a rank-ordering of the different display designs on each dimension. Any responses that were not

transitive were dropped from the analyses.

Responses to any follow-up interview questions were compiled according to their frequencies to help provide insight into the pilots' evaluation process. Such interview questions predominated in the instances where response transitivity was not observed. Any additional comments and suggestions were analyzed in a similar fashion.

This analysis was performed at two levels: (1) responses from all pilots were analyzed together; and (2) separate analyses of the responses given by IFR-pilots versus the responses given by VFR-pilots to determine any possible preference differences.

#### Apparatus

This study utilized a specially constructed dashboard/instrument panel designed to simulate existing instrument panels found in smaller general aviation aircraft. The instrument panel was designed so that two of the display sets could be integrated into the panel and presented at the same time. It was felt that such a simulated environment would increase the "realism" of the evaluation context, and at the same time maintain the fidelity of the display as it will appear when fully developed and incorporated into aircraft (See Appendix D).

## RESULTS

### Demographic Descriptive Statistics

The range of hours flown for the VFR-rated pilots was 43 - 650 hours; the range was 540 - 13000 hours for IFR-rated pilots. The range of years as a pilot was 1 - 44 years for VFR-rated pilots and 2 - 39 years for IFR-rated pilots. Means appear in Table 1.

Table 1

### Mean Number of Hours and Years Flown as a Pilot

	<u>VFR</u>	<u>IFR</u>
Years	8.3	13.50
Hours	316.9	3669.25

An analysis of the types of ratings held by the IFR-rated pilots revealed that the 20 pilots held a combined total of 25 advanced ratings beyond the required minimum IFR rating. Other ratings held included Air Transport Pilot (ATP), Commercial Multi-engine Instrument (CMI), Certified Flight

Instructor (CFI), and Certified Flight  
Instructor-Instrument (CFII) (See Table 2).

Table 2

Ratings Held by IFR-Rated Pilots

<u>Rating</u>	<u>Number of Pilots With Rating*</u>
Air Transport Pilot (ATP)	7
Commercial Multi- Engine Instrument (CMI)	10
Certified Flight Instructor (CFI)	5
Certified Flight Instructor-Instrument (CFII)	3

\* Some pilots possess more than one rating

Criteria Statistics

Overall results summarized across all three display comparisons indicate that display A was perceived to be the least complex (question 3) of the three displays (see Table 3). It was also found that most subjects believed all three displays to be superior to the instrumentation that they were most familiar with (question 6) (see Table 4).

Table 3

Response Preferences of Each Pilot Group For Each Comparison On Questions 1-5

Question	Group					
	a		b		c	
	VFR		IFR		Overall	
	A vs B		A vs B		A vs B	
1 Localizer	4	5	9	9	13	14
2 Glideslope	6	4	8	11	14	15
3 Excessive clutter	4	0*	10	1**	14	1***
4 Position correction	6	4	9	9	15	13
5 Overall preference	5	4	9	11	14	15
	B vs C		B vs C		B vs C	
1 Localizer	7	3	13	5*	20	8*
2 Glideslope	4	6	9	10	13	16
3 Excessive clutter	9	0***	19	0***	28	0***
4 Position correction	6	4	12	8	18	11
5 Overall preference	7	3	12	8	19	11
	A vs C		A vs C		A vs C	
1 Localizer	8	2*	12	8	20	10*
2 Glideslope	6	4	11	8	17	12
3 Excessive clutter	8	0***	17	0***	25	0***
4 Position correction	7	3	13	16	20	9
5 Overall preference	8	2*	12	8	20	10*

\* p&lt;.10

\*\* p&lt;.05

\*\*\* p&lt;.01

a, b, c - samples may not total 10, 20, and 30 respectively due to response intransitivity and pilot indecision

Specifically, it was found that display B was judged to be less complex than display C for all subjects,  $p < .01$  ( $N=28$ ), as well as for IFR- and VFR-rated pilots analyzed separately. Display A was favored over display B by pilots as a whole,  $p < .01$  ( $N=15$  because of pilot response indecision), as well as by IFR-rated pilots,  $p < .05$ , ( $N=11$ ). The results for VFR-rated pilots were significant only at  $p < .10$ , ( $N=4$ ).

As mentioned, all three displays were judged to be superior to the instrumentation which the pilots normally used,  $p < .01$  ( $N=29$ ). Only two pilots felt that their instrumentation was as good as any of the three given displays (See Table 4). It should be noted however, that neither of these pilots were IFR-rated.

Table 4

Response Preferences of Each Pilot Group for New vs Old Display (Question 6)

(Question 6)	Group		
	VFR	IFR	Overall
A vs Old	5 1	8 0	13 1
B vs Old	2 0	7 0	9 0
C vs Old	1 1	5 0	6 1
<u>Total New vs Old</u>	<u>8 2*</u>	<u>20 0**</u>	<u>28 2**</u>

\*  $p < .05$   
 \*\*  $p < .01$



## DISCUSSION

The results indicate that display A was preferred over the other two displays, using excessive clutter as the criterion. Because the purpose of this EHSI is to ease the mental work-load of the pilot by simplifying the task of assimilating all of the relevant flight information, it was important to single out the least complex display that still yielded sufficient necessary information. Although display A was not found to be significantly superior to display B and display C using other criteria, it is important to note that neither display B nor display C was found to be superior to display A on any of the criteria. Thus, display A appears to be the most appropriate for the EHSI using the clutter criterion alone.

It is interesting to note that a majority of respondents preferred display A and display B over display C in most instances. The only exception was found using glideslope trend information (question 2) as the criterion. In this instance, display C was preferred over display B, while display A was preferred over display C, although neither of these response patterns were found to be statistically significant.

One interesting observation is that display A is

the only display which utilizes a moving symbol to represent the aircraft's position relative to the other displayed information. Because display A was preferred most often, it may be that this aspect of the display is relatively critical. Further investigation could determine this potential.

It should be noted that utility considerations will be irrelevant when determining which display should be used. That is, the cost of software programming for each display is approximately equal. Regardless of the display used, the required hardware will be the same.

Comments made by pilots indicate that pictorial displays do have advantages over instruments that are electromechanical or patterned after electromechanical designs. This corresponds to previous research by Carel (1965). The most common response given by the pilots was that the pictorial displays yielded more information by providing a "visual picture" of the approach. Almost all of the pilots felt that the displays would be easily learned and would result in faster flight corrections. These are advantages that Carel suggested could be realized using pictorial codes.

Comments solicited from the subjects also revealed a major concern regarding each of the three displays.

Several pilots believed that display C would be a much improved display if a multichromatic monitor could be used. It was felt that this would reduce the clutter. Display B was perceived by several pilots as being confusing because of the existence of the horizontal line that corresponds to the glideslope indicator. This line appeared ambiguous to some pilots and confusing to others. One pilot felt display B was annoying. Although there were no major complaints regarding display A, one pilot suggested that it could be improved by incorporating pitch and bank information into the center crosshair. Other pilots indicated that raw glideslope data be incorporated, regardless of which display is used.

One cautionary note concerns the way in which question 3 was worded. It is possible that pilots would have responded somewhat differently if the question had asked which display contained "sufficient detail" rather than "excessive clutter." This wording may have presented a demand characteristic, and response patterns might change if the wording were altered. This is a real possibility because the preferences on question 3 did not carry over to overall preferences (question 5), except for the comparison between display A and display C (at a marginal level of significance).

Taken together, these results indicate that display A is most appropriate for use in the EHSI, followed closely by display B; display C placed a distant third. Follow-up research should examine preferences between revised versions of display A and display B. The revisions should incorporate the above-mentioned changes suggested by several of the pilots. An appropriate test of significance for future comparisons could be the Wilcoxon matched-pairs signed-ranks test (Daniel 1978), which offers more power when the sample size is limited, and allows magnitude estimations of given preferences.

Eventually, care should be taken to determine if preferences change in the context of actual flight conditions. It is difficult to say at this time whether preferences might change "in the air" as compared to "on the ground." It is possible that some pilots might eventually favor increasing the complexity of the display once they become familiar with it. If so, the display can probably be customized according to the personal preferences of the individual pilot.

In addition, there is a potential problem if the rate of information update to the display exhibits a lag or delay. In this instance, the display will not react immediately to the actual changing conditions as they exist outside the aircraft. This may cause many

pilots to exhibit anxiety toward the display or even result in pilots not trusting the display. If this is the case, many pilots may choose to ignore the EHSI. To the extent that the rate of update is comparable to the inherent small lag found with typical electromechanical displays, this potential problem should be minimized.

## REFERENCES

- Carel, W.L. (1965). Pictorial displays for flight. Office of Naval Research. (contract NONR 4468 (00)). Research and Development Division. Hughes Aircraft Company, Culver City, California.
- Cooper, G.E. (1957). Understanding and interpreting pilot opinion. Aeronautical Engineering Review, 16, (30), 47-56.
- Daniel, W.W. (1978). Applied Nonparametric Statistics. Boston: Houghton Mifflin.
- Dyer, S.A. (1982). A proposed electronic horizontal situation indicator for use in general aviation aircraft. IEEE Proceedings on navigation and communication. 198-205.
- Hofer, E. (1986). On surveys of expert opinion. Nuclear Engineering and Design, 93, 153-160.
- Johnson, S.J. & Roscoe, S.N. (1972). What moves, the airplane or the world? Human Factors, 14, (2), 107-129.
- Kantowitz, B.H. & Sorkin, R.D. (1983). Human Factors: Understanding people-system relationships. New York: John Wiley & Sons.
- Kershner, W.K. (1969). Instrument Flight Manual. Iowa State University Press.
- Lagerberg, J.D. (1987). An electronic horizontal situation indicator and development system. Unpublished master's thesis.
- Lerner, J.L. (1983). The automated cockpit. IEEE Spectrum, 2, p.54.
- McDonnell, J.D. (1969). An application of measurement methods to improve the quantitative nature of pilot rating scales. IEEE Transactions on Man-Machine Systems, 10, (3), 81-92.
- Nunnally, J.C. (1979). Psychometric Theory (2nd Ed.). New York: McGraw-Hill.
- Olsen, M.H. & Ives, B. (1981). User involvement in system design: An empirical test of alternative approaches. Information and Management, 4, 183-195.

- Robertson, C.H. (1987). Graphical page development of an EHSI. Unpublished Master's Thesis.
- Roscoe, S.N. (1968). Airborne displays for flight and navigation. Human Factors, 10, (4), 321-332.
- Roscoe, S.N. & Williges, R.C. (1975). Motion relationships in aircraft attitude and guidance displays: a flight experiment. Human Factors, 17, (4), 374-387.
- Seigel, S. (1956). Non-Parametric Statistics. New York: McGraw-Hill.

APPENDIX A

STATEMENT TO PILOTS

The purpose of this study is to investigate which of one of three display designs is superior to the other two for use in an Electronic Horizontal Situation Indicator (EHSI). A number of pilots including yourself have been asked to help provide the necessary information through your own opinions given in response to a short questionnaire.

You are asked to respond to the questionnaire after viewing each pair of display designs. To answer each question, you must decide which of the two different displays in each pair is superior to the other based on your opinion. After you have viewed each of the three display pairs and have answered all of the questions, your part in the study will be complete.

Your participation in this study as well as your responses will be anonymous. Feel free however, to ask any questions you may have regarding the study or your participation in it. Your input will be used to help determine which display design may be most appropriate for use in an EHSI being developed at Kansas State University.

While there are no foreseeable risks or discomforts to you inherent in this study, you may withdraw from the study any time you wish.



APPENDIX B

Questionnaire

In choosing between the two display sets labeled \_\_\_\_\_ and \_\_\_\_\_, which display design:

1. Do you believe best presents trend information relative to the localizer?
2. Do you believe best presents trend information relative to the glideslope?
3. Do you find to be the more "cluttered" (excessive representation)?
4. Do you feel is more clear as to what the pilot must do in correcting his/her position?
5. Would you prefer to use in your aircraft?
6. Is the preferred display design an improvement over the display system you currently use? Why? Why not?

APPENDIX C-1

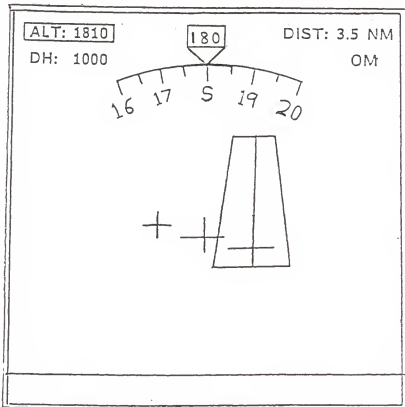
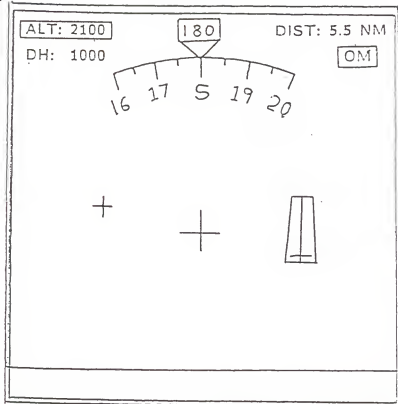

APPENDIX C-2

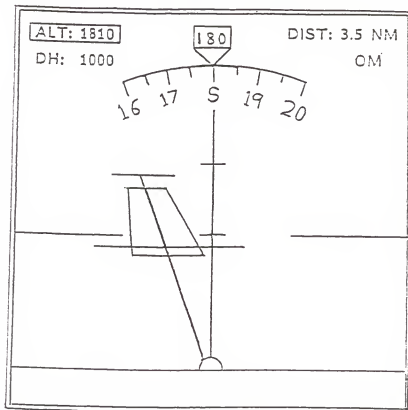
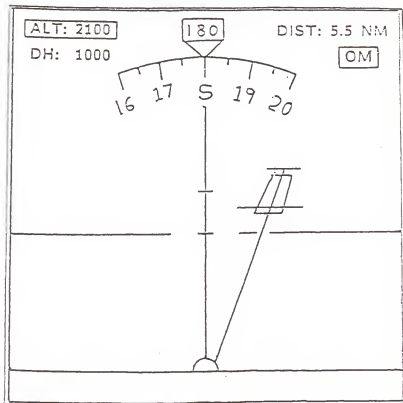

APPENDIX C-3

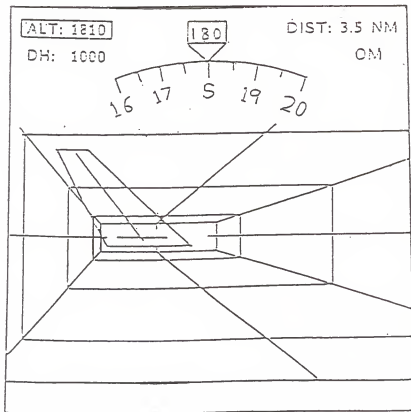
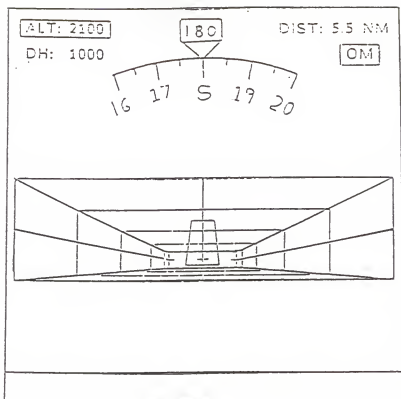

Appendix D

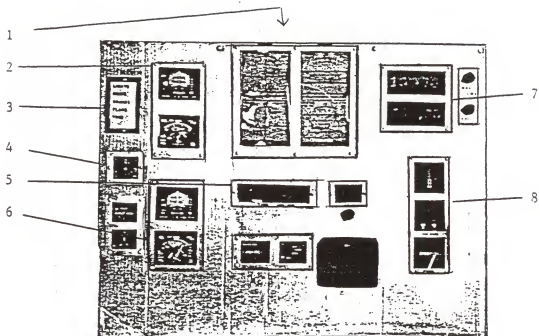

Simulated Cockpit Dashboard

- 1 New display configuration
- 2 Typical navigation displays
- 3 Status indicator displays
- 4 Compass
- 5 Clock
- 6 Automatic direction finder
- 7 Navigational communication representation
- 8 Engine status indicators

USER PREFERENCE EVALUATIONS  
OF DIFFERENT CONFIGURATIONS OF AN  
ELECTRONIC HORIZONTAL SITUATION INDICATOR

by

Mark D. Reiff

B.S., IOWA STATE UNIVERSITY, 1985

AN ABSTRACT OF A REPORT

submitted in partial fulfillment of the  
requirements for the degree

MASTER OF SCIENCE

Psychology

Kansas State University  
Manhattan, Kansas

1988

## ABSTRACT

The development of an Electronic Horizontal Situation Indicator (EHSI) using pictorial displays has become possible with the recent development of digital avionics technology. While pictorial displays possess advantages over non-pictorial displays, little research exists as to how information should be displayed and what it should look like.

Using a sample of 30 male pilots, each pilot compared and evaluated three different displays, two at a time and with respect to each other, according to a questionnaire focusing on information corresponding to the localizer, glideslope, display clutter, position correction, and personal use preferences.

The sign-test was used to analyze the pilot responses for each question for each display pair comparison. The results indicated that pilots as a whole preferred the display that utilized the minimum level of complexity.