

# IRRIGATION MANAGEMENT

S E R I E S

## Irrigation Water Measurement

**Danny H. Rogers**  
Extension Agricultural Engineer

**Richard D. Black**  
Extension Agricultural Engineers

**Cooperative Extension Service**  
**Kansas State University**

Irrigation is the largest water use in Kansas. There are about 3 million irrigated acres, of which nearly 95 percent is supplied by groundwater. Unfortunately, groundwater levels have been declining in most of the major irrigated areas due to overpumping, causing concern over the long term water availability from these aquifers.

Improved irrigation water management is needed, but without water measurements it is impossible to determine current usage and what management must accomplish. Measuring water use is a first step. Several groundwater management districts have installed a mandatory plan or are discussing how to accomplish metering of all irrigation water.

Water measurements provide the data necessary for:

1. Determining irrigation efficiency;
2. Improving water management;
3. Monitoring pumping plant performance;
4. Detecting well problems; and
5. Completing annual water use reports.

Just as there are a number of benefits for measuring irrigation water, there are a number of ways of doing the job. The more common methods are listed below.

### PROPELLER METERS

Propeller meters are one of the most common, convenient and accurate devices available for measuring irrigation water. Propeller meters are in-line devices that relate flow velocity and pipe cross section area to give a flow rate, volume, or both.

Flow velocity is measured with a propeller or impeller mounted on a shaft in the pipe. The meters are normally installed so the propeller is centered in the pipe with its centerline running on or parallel to the pipe axis. The propeller is connected to an indicating head which registers flow rate, volume, or both.

Propeller meters can be installed in any position - vertical, horizontal or at an angle. But, no matter how they are installed, the pipe must always be flowing full for accurate measurement. The meter also must be installed at an adequate distance from valves, elbows or other fittings which may disturb the flow. For more discussion of propeller

water meters, see "Guidelines for the Use of Propeller-type Irrigation Water Meters," Cooperative Extension Service publication L-869.

### PITOT TUBE

A pitot tube can be used to determine the velocity of flow in a pipe. If the velocity is measured at proper points across the pipe diameter an average may be computed and the flow rate computed from the cross-sectional area.

The simplest pitot tubes are small L-shaped tubes (Figure 1). Water rises in the tube when it's placed in a pipe with the open end facing the flow. The height of the water above the open end of the tube is a measure of the velocity of flow at that point, plus the pressure. By attaching another tube to the side wall of the pipe, one can measure the pressure component. The difference is the velocity of the flow.

A pitot tube normally indicates velocity at only one point in the pipe, but velocity in a pipe varies. It is normally highest at the center of the pipe and decreases toward the pipe walls. Because of this, an average velocity is usually computed by taking several readings at different locations in the pipe. A series of readings from near the pipe wall to the center of the pipe is sufficient if the flow is uniform and undisturbed. A series of measurements across the pipe is normally conducted, if possible, to determine if the flow is uniform. Some instruments use this principle but make only a single measurement at the centerline of the pipe. Obviously, if the flow is not uniform such instruments give a faulty reading.

Another popular pitot tube device is the "Collins meter," a probe that is a cylindrical tube with two holes near the center. A hole is drilled through both

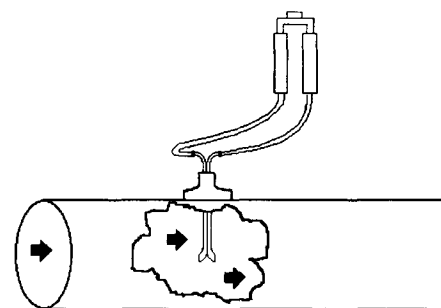

Figure 1. Simple pitot tubes.

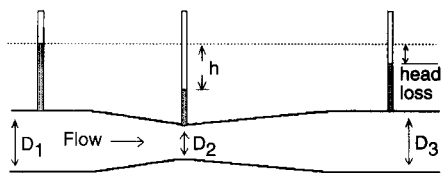

Figure 2. Diagram of a venturi meter.

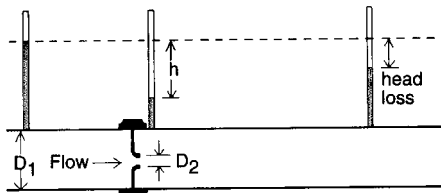
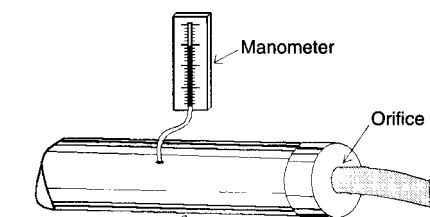

Figure 3. Diagram of flow nozzle.



Pump discharge pipe

Figure 4. Orifice meter.

walls of the pipe, and packing glands are secured into the holes to seal between the probe and the pipe, so no water will leak from the test pipe. With one hole in the probe facing directly upstream and the other facing downstream, a series of velocity measurements are taken as described above and the flow rate determined.

The other common pitot device is the "Anubar," a probe with two openings upstream and one down. It is installed in the pipe through a single hole using a packing gland to seal against leakage, but it is not moved. For each size of pipe there is an appropriate probe which averages the velocity; corrections may be made for slight differences in the pipe diameter. These devices are normally used for measuring flows in sprinkler lines where a sprinkler may be removed to install the meter.

## CONVERGENCE METERS

Convergence meters use differences in pressure or head to measure the flow rate. The flow of water through a constriction in a pipe lowers the pressure at the constriction. How much the head or

pressure drops between the unconfined flow and the constricted flow is a function of the flow rate.

Three common types of convergence meters are the venturi meter (Figure 2), the nozzle (Figure 3), and the orifice plate (Figure 4).

All of these devices work on the same principle. The major difference is the amount of loss that occurs due to flow through the device. The venturi meter has the least pressure loss by far, so it is the preferred method where energy losses are a concern. The nozzle is somewhat better than the orifice plate, but the difference is much smaller than the difference between the venturi meter and the nozzle or orifice plate.

All of these devices convert the pressure in the pipe upstream from an obstruction into increased speed of the water at the obstruction, which lowers the pressure where the speed is increased. Through a given amount of obstruction, this lowering of pressure is a constant for each rate of flow. The flow is determined by measuring the pressure change. The temperature of the water and the shape of the obstruction make a difference, but they are not considered in this discussion. Water temperatures in the field do not vary greatly, and each device generally has a rating table or characteristic curve which is used to determine flow from the pressure measurements.

All of these devices may be used within a pipe flowing full of water or a full pipe discharging freely into the atmosphere, but in the latter case, there is no advantage for a venturi meter or nozzle so orifice plates are used almost exclusively.

With full pipe flow, the difference in pressure is normally not more than a few feet of water if the meter has been properly sized and the range of flows is not great. As a consequence, normal pressure gauges are not suitable for the measurements. A foot of water pressure is less than 0.5 pound per square inch. So manometers, explained below, and other devices are used to measure pressure differences.

Convergence meters normally only measure the rate of flow, but it is possible to measure volumes. One venturi meter which does this uses a shunt line. The two pressure measuring points are connected with a pipe and, because of

the difference in pressure, water will flow through this pipe. In the shunt-line meter, this is measured with a household water meter. A restricting device is inserted into the shunt line, so the flow is proportional to the flow through the venturi. This type of system could be used for either the nozzle or the orifice, but the equipment has not been developed.

Pressure differences usually are measured with a manometer, which is simply a glass or plastic tube in which one can see the level to which water will rise at a given pressure. If the difference in pressure between two points is required, an inverted U-shaped tube may be used to measure the difference with a single reading. Manometer measurements are generally more accurate than pressure gauge readings, because 1 pound per square inch pressure will cause a rise in water level of about 2.31 feet. Thus, even a crude measurement to the nearest inch reveals the pressure to the 0.04 psi, which is much better than most pressure gauges.

Properly installed orifice plates on open pump discharges can provide a fairly inexpensive and accurate way to measure flow rate. For simplicity, the pipe should be horizontal, with no elbows, valves or other fittings closer than 10 pipe diameters upstream from the orifice plate. The ratio of the orifice diameter to the pipe diameter should be great enough to cause an easily measurable pressure rise and the ratio must be known to select the proper discharge coefficient. A restriction of about 0.50 is a common starting point.

Using the manometer readings, the discharge can then be read from a table (see Table 1), or calculated:

$$Q = Ca\sqrt{2gh}$$

where:

Q = discharge, gpm

C = discharge coefficient, see Figure 5.

a = cross-sectional area of the orifice in square inches

g = acceleration due to gravity (32.2 feet per second squared)

h = head on the orifice in inches measured from the center of the opening

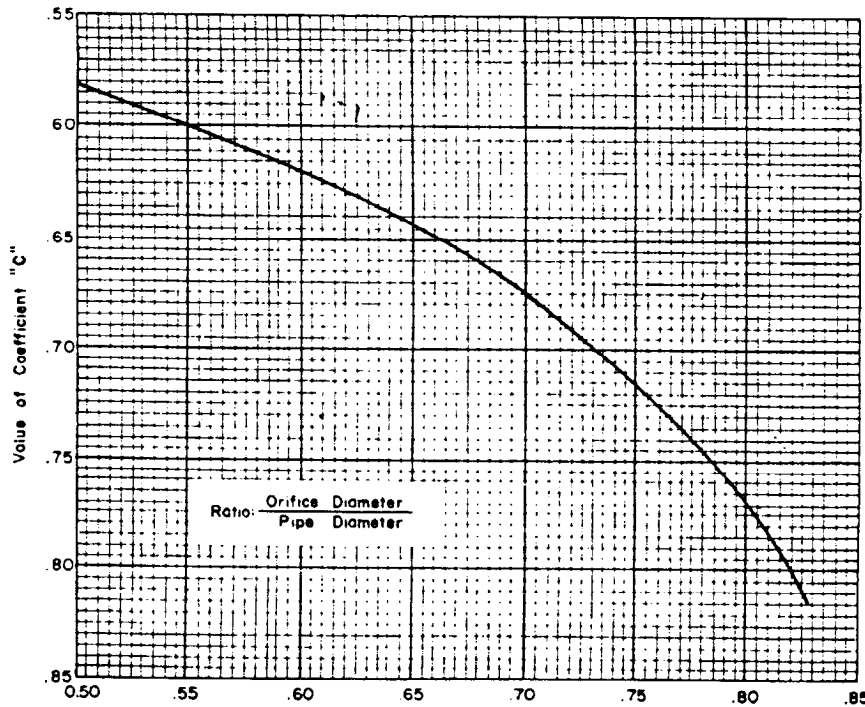

Figure 5. Ratio of orifice coefficients.

## TRAJECTORY MEASUREMENT

The trajectory or Perdue method estimates the flow rate from the end of a horizontal pipe using the horizontal and vertical components of the top of the discharging stream (Figure 6). A straight edge and plumb bob or a carpenter's square can be used for the measurements. The flow rate from a full horizontal pipe can be calculated from the equation:

$$Q = 3.61 AX/Y$$

where:

A = cross sectional area of discharge pipe in square inches.

X = horizontal distance in inches

Y = vertical distance in inches

Tables frequently give the flow from a given size of pipe based on the distance out to a point where the top of the jet has fallen 12 inches or, conversely, based on the amount of fall at some set distance from the end of the pipe.

With some modifications, this method can be used for pipes that are not flowing full and for vertical pipes.

## ULTRASONIC FLOW METERS

A recent development in water measurement devices are ultrasonic meters that are used primarily for survey and field testing of other meters. One major advantage is that they can measure flow

in a non-intrusive manner—the system does not have to be shut down to insert a probe or other equipment—but they are expensive.

Ultrasonic meters use one of three distinctly different principles: the Doppler effect, transit time, and eddy-correlation principle. Various models of meters using these principles are available. They may be important tools for the irrigation industry when used for large scale survey work and in-field meter accuracy verification, but are not likely to be used by individual irrigators.

## OTHER MEASUREMENT METHODS

**Turbine meters** are somewhat like propeller meters. One type uses a small paddle wheel that is inserted into the

side of the pipe and may be extended into the flow by various amounts depending upon the size of the pipe and the manufacturer's recommendations. The other is a simple propeller-type blade, which is mounted in the center of the pipe and rotates through a substantial portion of the pipe area.

The problem with the first type is that it essentially measures the velocity at a single point within the flow. If the measuring section is within a long straight length of pipe, it may work well with a standard rating. But, if anything disturbs the normal velocity distribution within the pipe, it must be calibrated in place, using another measuring device; if the flow is variable, it may need a calibration for each flow rate.

The second type is essentially a propeller meter with the same restrictions and benefits listed for propeller meters.

The other methods listed below are not commonly used in Kansas. However, there may be occasions when they can be used.

**Injection-Velocity Methods.** Salt velocity, color velocity and radioisotope methods are based on the injection of a solution or material into the stream flow. Time measurements taken from sensing elements downstream are then used to estimate the average time of travel, which should be closely related to the average velocity of flow. The amount of dilution can also be measured to obtain a volume-time relationship.

**Magnetic Flow Meters.** Their operation relies on the principle that a voltage is induced in an electrical conductor moving through a magnetic field. In this case, the conductor is the flowing water being measured. For a given field strength, the magnitude of the induced voltage is proportional to the velocity of the conductor.

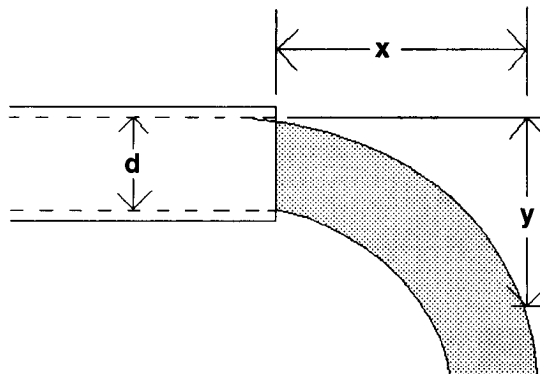

Figure 6. Required measurements to obtain flow from horizontal pipes.

**Proportional meters.** Proportional meters divert and measure a small, known percentage of the total flow, usually with a propeller-type sensor or positive displacement type of meter. (See the section on venturi meters).

**Deflection meters.** Flow rate also can be determined by measuring the force that moving water exerts on objects placed in the flow. Vanes or plates with sensing elements are placed in the stream to measure the deflection caused by the flowing water. The deflection is calibrated with flow rate to give a flow rate reading.

## SUMMARY

Increasing energy costs and decreasing water supplies point out the need for better water management, which requires knowing flow rates and volumes. Water measurement is one of the first steps in a total water management program.

In most cases, metering devices will pay for themselves in water savings, optimum yields and lowered energy costs.

The most common water measurement device is the propeller meter which can give both flow rate and flow volume. Other methods include pitot tubes, orifice plates, nozzles, venturi meters, and trajectory methods.

Additional information on flow measurement methods is available through Extension irrigation engineers, your county Extension agricultural agent, the Soil Conservation Service and irrigation equipment dealers.

## UNITS OF WATER MEASUREMENT

The units below are common water measurement terms, conversions and relationships.

### VOLUME:

Acre-inch (ac.in.): The volume of water required to cover an acre 1 inch deep.

Acre-foot (ac.ft): The volume of water required to cover an acre 1 foot deep.

1 cubic foot = 7.48 gallons = 62.4 pounds

1 acre-inch = 3,630 cubic feet = 27,154 gallons

1 acre-foot = 12 acre inches = 43,560 cubic feet = 325,851 gallons

1 cubic meter = 1,000 liters = 264.18 gallons

### FLOW RATE:

1 cubic foot per second (cfs) = approximately 450 gallons per minute (gpm)

1 acre-inch/hour = approximately 450 gpm = 1 cfs

Head (inches)	3-in. orifice		4-in. orifice		5-in. orifice		6-in. orifice		7-in. orifice	8-in. orifice
	4-in. Pipe	6-in. Pipe	6-in. Pipe	8-in. Pipe	6-in. Pipe	8-in. Pipe	8-in. Pipe	10-in. Pipe	10-in. Pipe	10-in. Pipe
	G.p.m.	G.p.m.	G.p.m.	G.p.m.	G.p.m.	G.p.m.	G.p.m.	G.p.m.	G.p.m.	G.p.m.
6	108	82	160	150	305	240	408	345		
8	122	94	185	170	350	280	458	395	600	935
10	133	104	205	190	393	316	508	445	666	1040
12	146	114	225	208	430	346	556	490	728	1120
14	157	123	243	224	465	376	599	530	785	1194
16	167	132	257	238	495	402	636	568	838	1266
18	178	140	271	252	524	426	672	604	887	1336
20	187	148	285	266	548	449	708	636	933	1404
22	197	156	299	279	572	470	744	664	979	1471
24	205	164	310	291	596	488	776	692	1022	1529
26	214	171	323	303	620	504	805	720	1064	1585
28	222	177	335	314	644	520	831	747	1104	1641
30	230	183	346	325	668	536	857	773	1143	1697
32	239	189	357	335	692	552	882	799	1181	1753
34	246	195	369	345	715	568	907	824	1218	1809
36	254	200	380	354	737	584	931	847	1251	1865
38	260	205	390	363	759	600	955	867	1281	
40	266	210	401	371	781	616	979	887	1311	
42	272	214	411	380	800	631	1001	906	1341	
44	278	219	420	388	820	645	1023	925	1371	
46	284	224	429	396	837	659	1045	944	1401	
48	290	229	440	405	855	672	1067	963	1431	
50	296	234	448	413	872	686	1089	982	1461	
52	302	238	457	421	888	700	1110	1000	1491	
54	307	243	465	429	904	714	1130	1018	1520	
56	313	248	472	437	919	727	1150	1036	1548	
58	317	252	480	445	934	739	1170	1052	1574	
60	323	257	489	453	948	751	1190	1068	1598	
62	328	262	496	461	961	763	1209	1084		
64	333	266	504	469	974	775	1227	1099		
66	338	271	513	475	988	787	1245	1113		
68	343	275	520	483	1002	799	1263	1127		
70	349	280	525	491	1016	811	1280	1140		

Table 1. Discharge from circular pipe orifices with free discharge.



## COOPERATIVE EXTENSION SERVICE, MANHATTAN, KANSAS

L-877

June 1993

Issued in furtherance of Cooperative Extension Work, acts of May 8 and June 30, 1914, as amended. Kansas State University, County Extension Councils, and United States Department of Agriculture Cooperating, Richard D. Wootton, Associate Director. All educational programs and materials available without discrimination on the basis of race, color, national origin, sex, age, or disability.

6-93-3M