

A STUDY OF GAS ABSORPTION WITH CHEMICAL REACTION
IN VARIOUS TYPES OF COLUMNS

by

MIN-SHUEY LIN

B. S., National Taiwan University, China, 1951

A THESIS

submitted in partial fulfillment of the

requirements for the degree

MASTER OF SCIENCE

Department of Chemical Engineering

KANSAS STATE COLLEGE
OF AGRICULTURE AND APPLIED SCIENCE

1956

TABLE OF CONTENTS

INTRODUCTION	1
THEORY	3
EXPERIMENTAL	11
Equipment:	11
Operating Procedures	24
Materials	26
Chemical Analysis	26
RESULTS AND DISCUSSION	28
Summary of Data	28
Discussion	29
CONCLUSIONS	44
ACKNOWLEDGMENTS	46
BIBLIOGRAPHY	47
APPENDIX	49

INTRODUCTION

In recent years, the application of gas absorption in chemical engineering practice has reached such a point that more kinetic studies are needed if this unit operation is to advance further. It is desirable to have a clear understanding and accurate description of the mechanism of the mass transfer process. It is even more immediately useful to have some scheme by which design specifications could be made on the basis of a minimum amount of laboratory data. Such a scheme would be especially valuable in the case where chemical reactions occur in the liquid phase either as an incidental phenomenon or as a part of the process itself.

The overall objective of the present investigation has been directed towards the formulation of a design scheme so that the performance data of "physical absorption" can be extrapolated to "chemical absorption". The experimental work dealt with the following:

- (1) Absorption of oxygen in water in a disc column.
- (2) Absorption of oxygen in sodium sulfite solution in a disc column -- the effect of catalyst.
- (3) Comparison of the characteristics of three representative types of columns for physical absorption -- wetted-wall, disc and packed columns.
- (4) The evaluation of the oxygen-sulfite system -- to see whether it would make a convenient test system for the comparison of chemical absorption in various types of columns.

The disc column was constructed by Hwu (12), in this laboratory. Its gas film characteristics were tested with the Ammonia-water system; the liquid film characteristics were tested with the CO_2 - water system. Tien (19) re-studied the gas film correlation by absorbing ammonia into phosphoric acid

solutions. He also extended the study to the absorption of Cl_2 in water, a typical case where physical absorption is followed by incidental chemical reaction, namely, the hydrolysis of dissolved molecular chlorine.

The disc column is a special laboratory device for measuring liquid film coefficient in physical and chemical absorption. Because of its resemblance to industrial packed column with respect to the flow pattern, it was postulated that the same relationship between k_L and k_L' observed in this column, should also hold in the packed column. (k_L is the liquid film coefficient for physical absorption as defined in equation (1) and k_L' is for the case where chemical reagent has been added to the liquid). The most direct way to test this postulation would be to repeat, in the laboratory, the absorption runs for which the industrial performance data are already available. However, except for a few instances such as the absorption of CO_2 into water with and without the addition of NaOH , the data are insufficient for this purpose.

The regularity of the flow pattern in the disc column actually lies somewhere between the two extremes of the wetted-wall column and the packed column. Therefore, it was deemed necessary to investigate the variations in flow pattern and their influence on absorption coefficients. One short wetted wall column and one glass Raschig ring packed column have been constructed and operated in parallel with the disc column for this purpose. The oxygen-water system was chosen as a typical case of physical absorption. There remained, then, the choice of the companion chemical absorption system.

The absorption of oxygen in sulfite solution has been used as a test system in the evaluation of mixing equipment (10)(3). According to Gallagher (10) the advantages of this system are as follows:

- (1) The rate of oxidation is proportional to the oxygen absorbed.
- (2) The rate of oxidation is independent of the sulfite concentration over a wide range of sulfite concentration.

(Gallagher also added that this system lends itself to simple laboratory investigation. This is a misstatement, however.)

In addition to these reasons, this system was chosen because of the possibility of controlling the reaction rate with catalyst. This would provide a way to detect the effect of reaction velocity constant on liquid film coefficient k_L' .

The direct comparison of observed rates of "physical absorption" to those of "chemical absorption" gives no information on the individual effect of such physico-chemical factors as diffusivity, solubility, etc. These factors are functions of temperature and concentration levels, which can not be closely controlled in the laboratory. However, method of correcting k_L values from one temperature to another is available (16) at least for physical absorptions. Therefore, the liquid film coefficients, not the rates, are compared in this work.

THEORY

A perfect theory which will give a rigorous expression for gas absorption, especially for those cases where they are accompanied by chemical reactions, has not yet been established. Most of the theories concerning gas absorption with chemical reaction are merely extensions of the physical absorption theories. Among the latter, the so-called two-film theory is regarded as the classical one. Since its first appearance in 1923, it has served the design engineers well. It offers an easily visualized model for

the inter-phase mass transfer mechanism; it also serves as a simple basis for design calculations. However, a more realistic model is needed in order to describe the behavior in such industrial equipment as a packed column. Also it has become apparent that in order to develop a workable design procedure to include the effect of chemical reactions, the classical two-film theory is not entirely satisfactory.

Notable contributions have been made recently in the re-evaluation of the theory, although none has emerged as a general method of correlation applicable to design calculations. Experimental data for various chemical systems, equipment and operating conditions continue to appear in the literature. Eventually this accumulation of experimental data may contribute to the formulation of a more general theory. On the other hand, there is a tendency for the author to rush to a generalized conclusion on the basis of his own particular set of data. Thus one finds in the literature a myriad of empirical equations, each being applicable only to a set of highly restricted conditions. Often these empirical correlations tend to obscure the basic assumptions involved instead of clarifying them. Therefore, it ^{was} necessary to review the major theories that have been the underlying foundation of the current work. The basic concept of each theory and the limitations in its application are described briefly. Also some of the mathematical relationships are derived here for clarity.

The Two-film Theory: Lewis and Whitman (13) proposed that there exist, at the interface, two thin layers of liquid and gas which remain stagnant no matter how turbulent the flow in the bulk of the gas and the liquid phases may be. These very thin, stagnant layers of liquid and gas are the so-called 'films'. It is assumed that the main part of the liquid and the gas phases

are sufficiently well mixed that the concentration gradient is restricted to the stagnant films, and that there is no accumulation of material in the films. The mathematical expression of this theory is

$$N = k_L (C_i - C_L) = k_G (p_G - p_i) \quad (1)$$

where N = lb-moles of gas absorbed per hour per square foot interfacial area.

C = Liquid concentration in lb-moles per cu. ft.

p = partial pressure in atmosphere.

Subscripts G , i and L denote the gas phase, interface, and the liquid phase respectively.

k = mass transfer film coefficient.

The diagrams on Plate X in the Appendix would help to visualize the postulated model.

The mass-transfer equation states that

$$N = -D \left(\frac{\partial C}{\partial x} \right) \quad (2)$$

$$\text{or } N = D \frac{C_i - C_L}{X_L} \quad (3)$$

where D = diffusivity in sq. ft. per hour and X_L = thickness of the hypothesized liquid film in feet. The comparison of equations (1) and (3) shows that

$$k_L = \frac{D}{X_L}$$

which means that k_L is proportioned to D . However, the experimental data shows that k_L is proportional to \sqrt{D} (16). Danckwerts and Kennedy concluded that X_L must also be proportional to \sqrt{D} (6).

Higbie's Penetration Theory: Higbie (11) suggested that the mechanism of physical gas absorption resembles an unsteady state diffusion of a gas through a stagnant liquid of a homogeneous initial concentration C_0 . Since the rate of diffusion (or penetration) in most cases is so slow and the time of contact is so short that it is reasonable to consider the depth of the

liquid layer to be infinite. It is also assumed that equilibrium is always attained at the interface. A differential equation resulting from these concepts is as follows:

$$\frac{\partial C}{\partial \theta} = D \frac{\partial^2 C}{\partial x^2} \quad (5)$$

The boundary conditions are:

$$\begin{array}{llll} C = C_0 & \text{at} & \theta = 0 & x > 0 \\ C = C_1 & \text{at} & \theta > 0 & x = 0 \\ C = C_0 & \text{at} & \theta > 0 & x = \infty \\ C = C_1 & \text{at} & \theta = \infty & x > 0 \end{array}$$

where C_0 = initial liquid concentration, homogeneous throughout the liquid phase.

C_1 = liquid concentration at the interface, independent of time.

θ = time of exposure or contact.

x = distance in liquid phase, measured from the interface.

Eq. (5) can be solved with the aid of Laplace Transformation (Appendix). The solution is:

$$C = C_0 + \frac{C_1 - C_0}{\sqrt{\pi D \theta}} \int_x^{\infty} e^{-\frac{x^2}{4D\theta}} dx \quad (6)$$

which expresses the liquid concentration in terms of the distance from the interface and the time of contact.

Fick's or Graham's law expresses the diffusion of a dissolved gas through a liquid by the following equation:

$$dq = -DA \left(\frac{\partial C}{\partial x} \right) d\theta \quad (7)$$

where dq = moles of gas absorbed during time $d\theta$

A = interfacial area.

Note that this is the same as equation (2) above. To evaluate $\left(\frac{\partial C}{\partial x} \right)$, differentiate equation (6) with respect to x ,

$$\frac{\partial C}{\partial x} = \frac{C_1 - C_0}{\sqrt{\pi D \theta}} \frac{d}{dx} \left(\int_x^{\infty} e^{-\frac{x^2}{4D\theta}} dx \right) = \frac{C_1 - C_0}{\sqrt{\pi D \theta}} \left(-e^{-\frac{x^2}{4D\theta}} \right) \quad (8)$$

Then the cumulative amount of the gas absorbed up to time θ is:

$$q' = -DA \int_0^\theta \left(\frac{\partial c}{\partial x} \right)_{x=0} d\theta = (C_i - C_o) A \sqrt{\frac{D}{\pi}} \int_0^\theta \frac{d\theta}{\sqrt{\theta}} = 2A(C_i - C_o) \sqrt{\frac{D\theta}{\pi}} \quad (9)$$

The average rate of absorption per unit area up to time θ is:

$$N' = \frac{q'}{A\theta} = 2(C_i - C_o) \sqrt{\frac{D}{\pi\theta}} \quad (10)$$

Here k_L varies with \sqrt{D} and $\frac{1}{\sqrt{\theta}}$. The latter is consistent with the fact that agitation (shortening the period of exposure) increases the mass transfer coefficient k_L .

Danckwerts' Penetration Theory: (5) In this theory, it is supposed that the fresher liquid patches from the interior of the liquid body are constantly coming up to the surface and replacing the old ones. Between its first exposure and its ultimate replacement, the liquid surface patch absorbs gas at a rate approximately equal to the rate of absorption into a stagnant liquid of infinite depth exposed for the same length of time. At a given moment the surface of a stirred liquid is a combination of patches, or elements, of different 'ages' which are absorbing at different rates. Therefore, the average rate of absorption depends on the distribution of the elements of the surface among the various 'age-groups'. It is assumed that the mean rate of production of fresh surface is constant and equal to 'S', and the chance of each element to be replaced is independent of its age.

Let the area of the surface comprising those elements having ages between θ and $(\theta + d\theta)$ be $\phi(\theta)d\theta$. At steady state this quantity does not vary with time. In a short time interval 'd θ ' the area entering the age group " θ to $(\theta + d\theta)$ " from the age group " $(\theta - d\theta)$ to θ " will be $\phi(\theta)d\theta$. This is also equal to the area in age group " $(\theta - d\theta)$ to θ " less that which is replaced

by fresh surfaces during the same time interval $d\theta$. Thus,

$$\phi(\theta)d\theta = \phi(\theta - d\theta) d\theta (1 - Sd\theta) \quad (11)$$

where constant 'S' is the mean rate of production of fresh surfaces, expressed as fraction of the existing surface per unit time.

Before going any further with the mathematical development, note that the foregoing analysis can be applied to an analagous but more familiar situation such as the age distribution among the human inhabitants in the state of Kansas. This analogy is illustrated in the Appendix.

Since

$$\phi(\theta - d\theta) \approx \phi(\theta) - \frac{d\phi(\theta)}{d\theta} d\theta \quad (12)$$

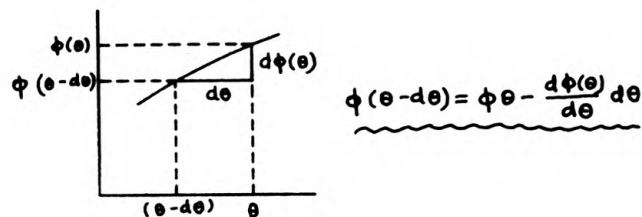

substituting Eq. (12) into Eq. (11), and dividing by $d\theta$,

$$\phi(\theta) = \phi(\theta) - \frac{d\phi(\theta)}{d\theta} d\theta - S\phi(\theta)d\theta + Sd\phi(\theta)d\theta \quad (13)$$

neglecting the $Sd\phi(\theta)d\theta$ term,

$$\frac{d\phi(\theta)}{d\theta} = -S\phi(\theta) \quad (14)$$

For a unit area,

$$\int_0^{\infty} \phi(\theta)d\theta = 1 = - \int_0^{\infty} \frac{d\phi(\theta)}{S} \quad (15)$$

therefore,

$$\phi(\theta) = S e^{-S\theta} \quad (16)$$

The rate of absorption into those surface elements having age ' θ ' and an area of $\phi(\theta)d\theta = S e^{-S\theta}d\theta$ is equal to the absorption rate of a stagnant liquid under the same conditions. Thus from Eqs. (7) and (8)

$$\frac{dq}{d\theta} = -DA \left(\frac{\partial C}{\partial x} \right)_{x=0} = DA \frac{C_i - C_o}{\sqrt{\pi D \theta}} = (C_i - C_o) (S e^{-S\theta}) \sqrt{\frac{D}{\pi \theta}} \quad (17)$$

and the average absorption rate of a unit surface area having ages from 0 to ∞ is

$$N = \left[(C_i - C_o) \sqrt{\frac{D_S}{\pi}} \int_0^{\infty} \frac{s e^{-s\theta}}{\sqrt{s\theta}} d\theta \right] / \int_0^{\infty} s e^{-s\theta} d\theta = (C_i - C_o) \sqrt{\frac{D_S}{\pi}} \sqrt{\pi} = (C_i - C_o) \sqrt{D_S} \quad (18)$$

where $\sqrt{D_S}$ is corresponding to k_L in the film theory.

All these theories are subject to certain limitations when applied to column operation. Higbie's theory, which is based on a stagnant liquid, requires the following conditions: First, the time of exposure must be very short in comparison to the time required to bring the liquid to its equilibrium concentration so that the liquid layer, which is actually thin, may be considered as if it were of infinite depth; second, the liquid flow must be laminar (no intermixing effect).

In laboratory studies, the second condition may be closely approached with the addition of surface active agent in the liquid (7)(14). The time of exposure of the liquid passing through a column may be estimated by the falling liquid equation (14)(8) with various simplifying assumptions, such as constant velocity distribution (14), parabolic velocity distribution across the liquid layer (7), etc.

These physical absorption equations, as derived above on the basis of three different models, has been extended to the cases where chemical reactions take place in the liquid phase and are shown in (6). The types of reactions considered include very fast irreversible, first order irreversible and first order reversible reactions. Expressions for the ratio of the absorption rate with chemical reactions to that without chemical reactions were developed from each model. It has been shown that the three models lead to closely similar predictions about the effect of chemical reaction and other physico-chemical factors

(solubility, diffusivity, reaction rate, etc.) on absorption rates. This means that it would not be feasible to find out which model is the correct one by experimental studies of the effect of such factors on absorption rates. On the other hand, this means that it would be possible to use either one of the three models as a basis for correlation, whichever is more convenient to apply according to the available design data. Danckwerts claimed that, whether with or without chemical reactions, if the absorption rate of gas into a stagnant liquid has been measured experimentally, then it should be possible to use either his or Highbie's penetration theory to predict absorption rates in a packed column without the necessity of knowing explicitly the order of reaction, diffusivity, etc. In other words, he maintained that in order to extrapolate the "physical absorption" data to "chemical absorption" it would not be necessary to perform a pair of physical and chemical absorptions in a laboratory column which resembles the flow pattern in the industrial column. To verify this claim, Dankwerts and Kennedy designed a so-called "rotating drum" (6) with which to expose a film of liquid to a gas for some controlled short periods. However, his experimental results with CO_2 showed that neither the Highbie's nor Danckwerts' penetration theory could be used to predict the required absorption rate satisfactorily.

The failure of Danckwerts' and Kennedy's first try at an experimental proof led to the conclusion that hydrodynamic consideration is important in transposing the data obtained from one type of column to another. It follows then that two ways of further investigation should be taken. One is to revise Dankwert's theoretical development. Probably, the expression for the surface age distribution and renewal rate can be modified to take into account the hydrodynamic characteristics of different column. The other way is to

compare, experimentally, the performance data of several representative types of columns. The latter approach has been adopted for the present work. Three types of columns of varying complexity have been constructed for this purpose. They are: short wetted-wall column, disc column, and packed column.

EXPERIMENTAL

Equipments

The equipments used in this experiment were a short wetted wall column, a disc column and a packed column with glass Raschig rings. The arrangement of these columns along with the auxiliary equipments are shown on Plates I and II. The wetted wall column is also shown on Plates I and IV. The Pyrex glass section was fabricated by the Dow Corning Glass Works on special order. The stainless steel end pieces and supporting plates were machined in the College power plant shops. Tygon sheet was used as the gasket material. The dimensions and the top and side views of the column proper are shown on Plate III. The whole assembly was mounted on three threaded iron rods.

The dimensions of the disc column are shown in the Appendix. It consists of a Pyrex glass column of $1 \frac{1}{8}$ inches inside diameter, 34 inches in height and $\frac{1}{16}$ inches in wall thickness. A string of 35 unglazed ceramic discs of 1.5 cm. diameter and 0.48 cm. thickness was placed along the axis of the column. The discs were so mounted on a 1.5 mm. Fiberglas cord that each disc was at right angle to the neighboring ones.

The packed column, as shown on Plate VI, consisted of a Pyrex glass pipe of 2-inch inside diameter and 24-inch length. The $\frac{1}{4}$ -inch glass Raschig rings were supported by a perforated stainless plate. The clearance between

EXPLANATION OF PLATE I

Experimental Layout

A: Liquid tank	O: Inlet liquid sampling valve
B: Liquid pump	P: Sampling bottle
C: Liquid rate regulating valve	a: Cylinder gas
D: Liquid flowmeter	b: Pressure regulator
E: Liquid inlet temperature measuring thermometer	c: Gas rate regulating valve
F: Liquid inlet valve	d: Gas flowmeter
G: Disc column	e: Gas saturator
H: Wetted-wall column	f: Gas inlet temperature measuring thermometer
I: Packed column	g: Gas inlet valve
J: Liquid outlet valve	h: Gas inlet pressure measuring manometer
K: Drain valve	i: Gas outlet valve
L: Liquid level regulator	j: Gas outlet pressure measuring manometer
M: Liquid outlet temperature measuring thermometer	k: Column pressure regulating valve
N: Outlet liquid sampling valve	l: Gas outlet temperature measuring thermometer

PLATE I

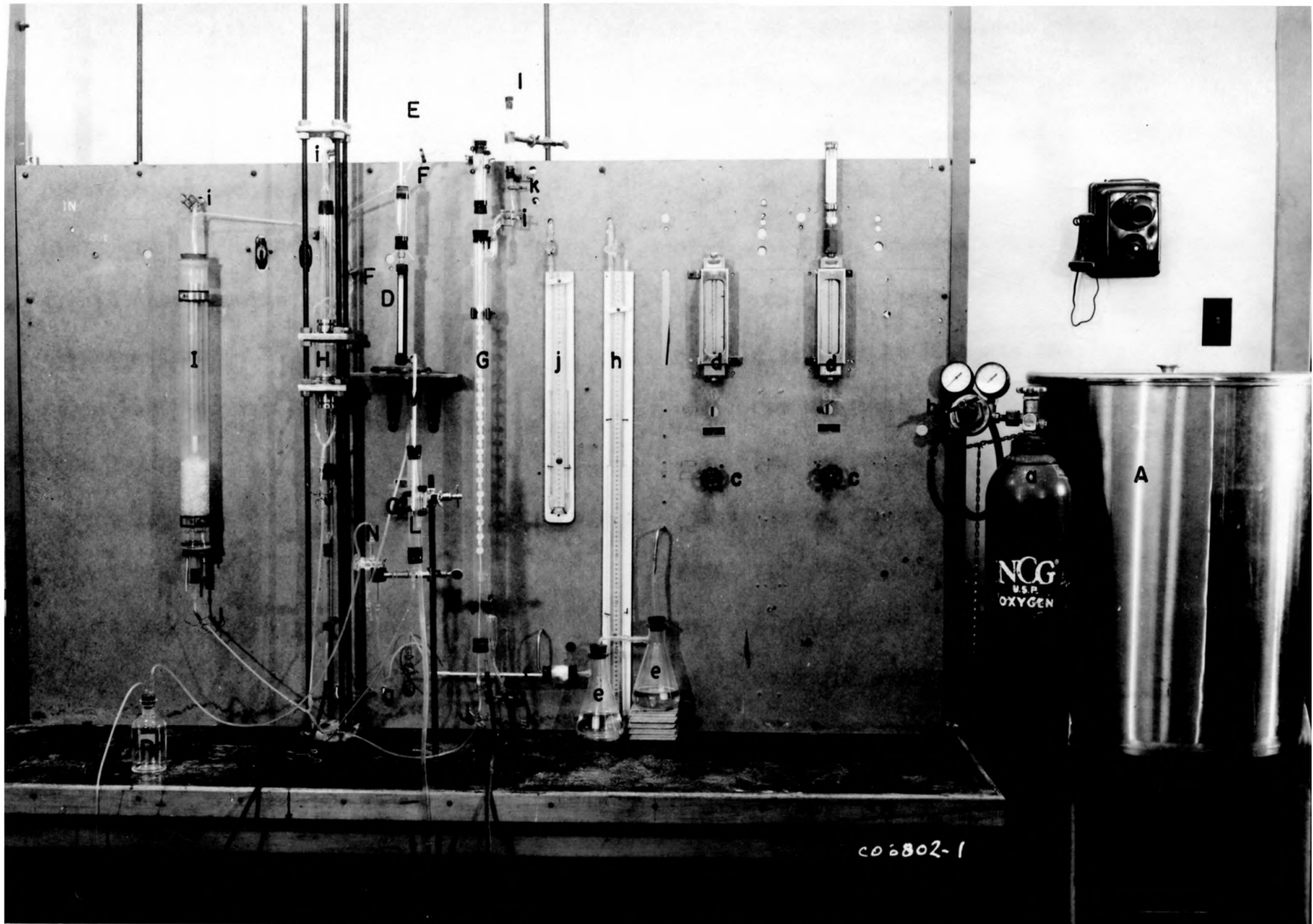

EXPLANATION OF PLATE II

Schematic Diagram of Experimental Layout

L:	Liquid Tank	ISV:	Inlet liquid sampling valve
P:	Liquid pump	S:	Sampling bottle
LRRV:	Liquid rate regulating valve	G:	Cylinder gas
LF:	Liquid flowmeter	PR:	Pressure regulator
LIT:	Liquid inlet temperature measuring thermometer	GRRV:	Gas rate regulating valve
DC:	Disc Column	GF:	Gas flowmeter
WWC:	Wetted-wall column	GS:	Gas saturator
PC:	Packed column	GIT:	Gas inlet temperature measuring thermometer
LOV:	Liquid outlet valve	GIV:	Gas inlet valve
DV:	Drain valve	GIM:	Gas inlet pressure measuring manometer
LLR:	Liquid level regulator	GOV:	Gas outlet valve
LOT:	Liquid outlet temperature measuring thermometer	GOM:	Gas outlet pressure measuring manometer
OSV:	Outlet liquid sampling valve	CPRV:	Column pressure regulating valve
LIV:	Liquid inlet valve	GOT:	Gas outlet temperature measuring thermometer

PLATE II

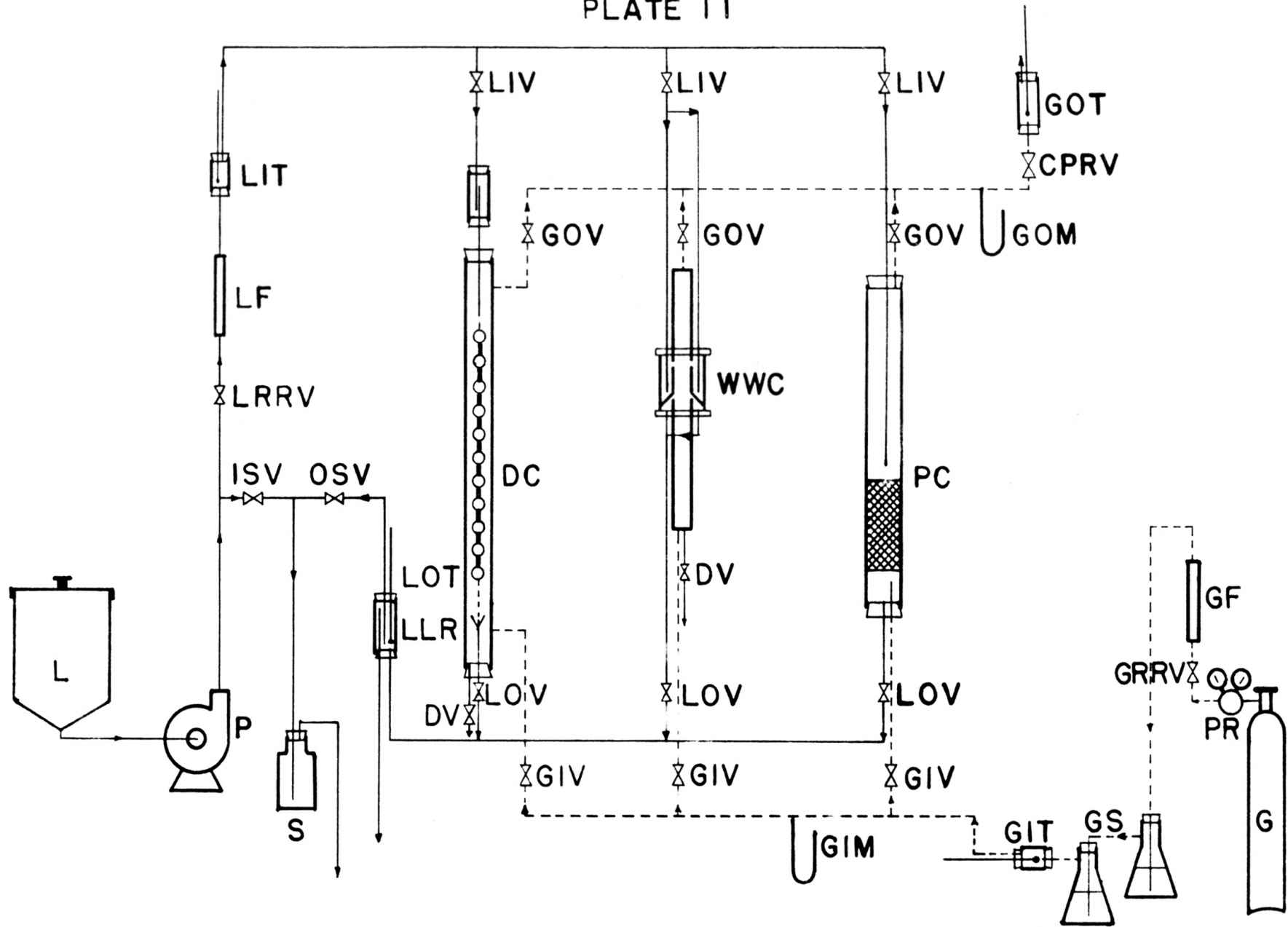

EXPLANATION OF PLATE III

Dimension of the Wetted-Wall Column

Upper: Top view

Lower: Side sectional view

PLATE III

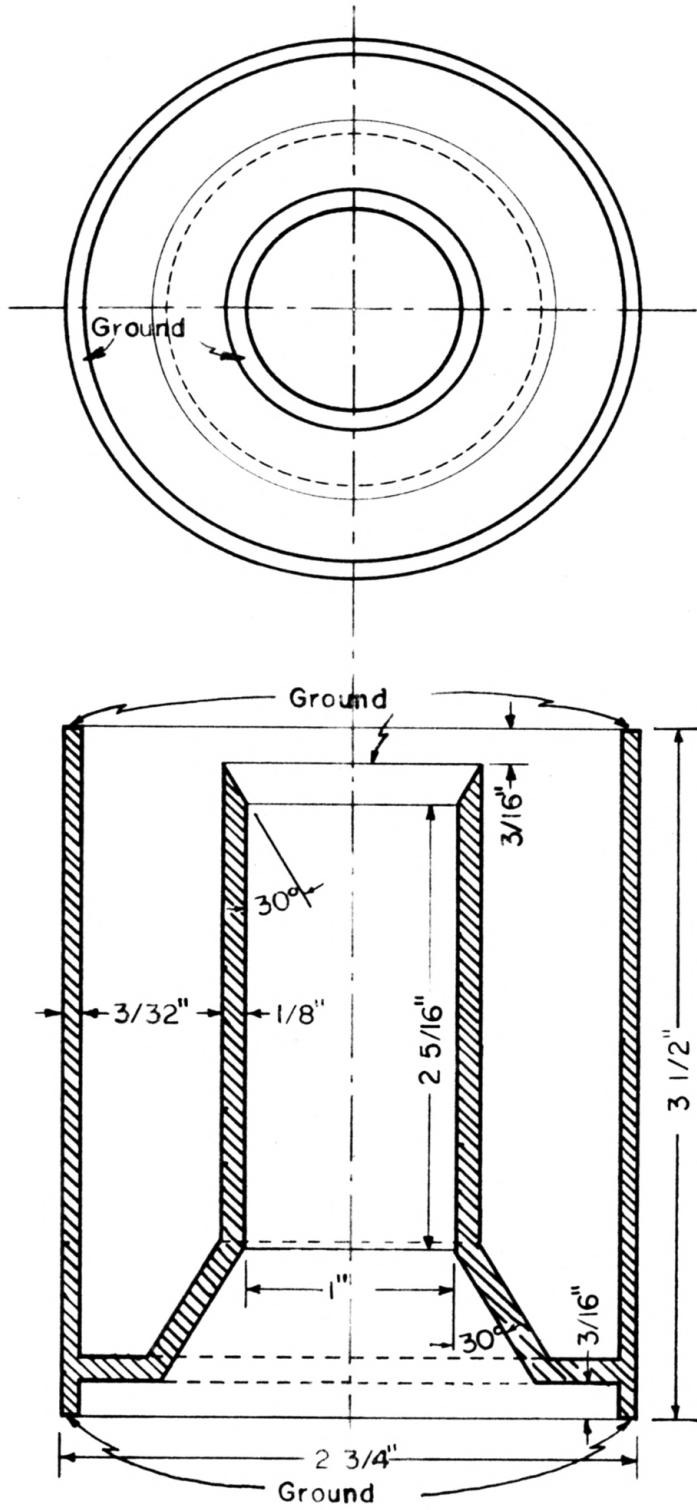

EXPLANATION OF PLATE IV

Close-up View of the Wetted-Wall Column

- A. Column proper
- B. Liquid inlet
- C. Liquid outlet
- D. End piece
- E. Supporting plate
- F. Supporting rod
- G. Gas inlet line
- H. Gas outlet line
- I. Tygon sheet gasket
- J. Locking nut

PLATE IV

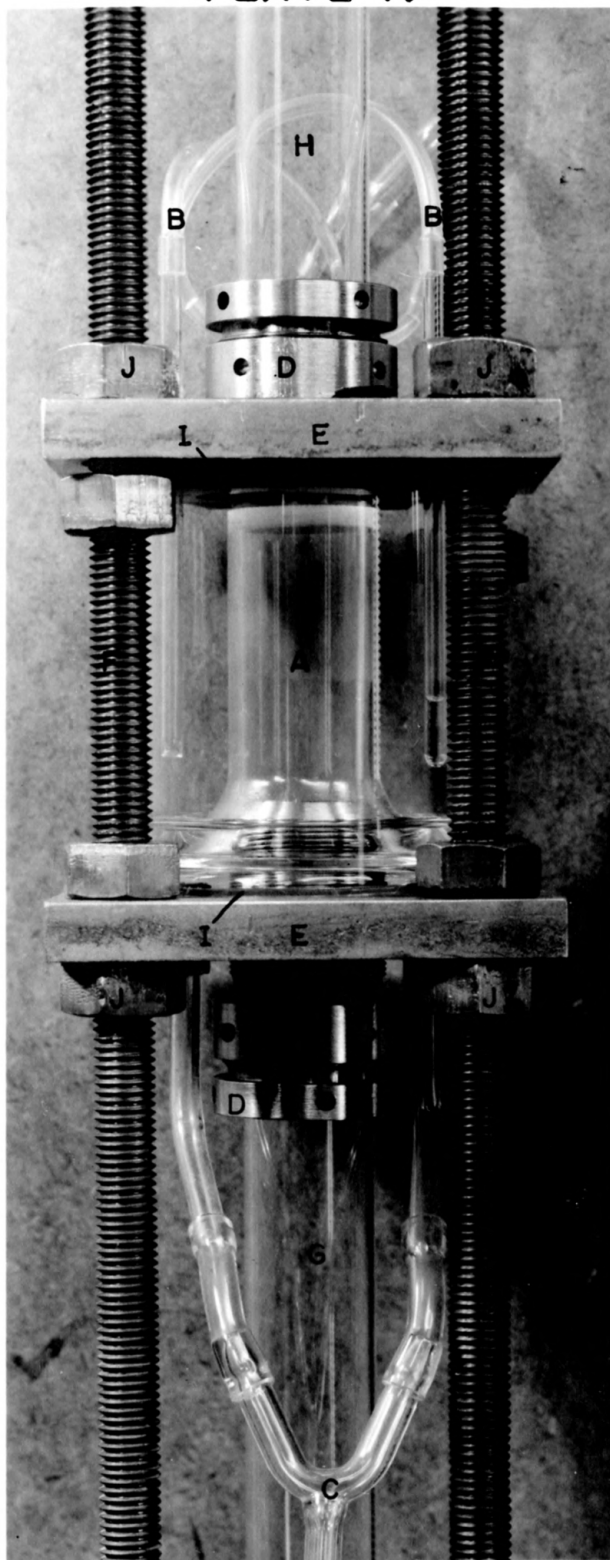

EXPLANATION OF PLATE V

Close-up view of the Disc Column

- A. Pyrex tube
- B. Ceramic disc
- C. Supporting Fiberglas cord
- D. Liquid feed jet
- E. Long stem funnel
- F. Gas inlet
- G. Gas outlet
- H. Liquid feed cylinder
- I. Liquid outlet
- J. Drain for splashed liquid

PLATE V

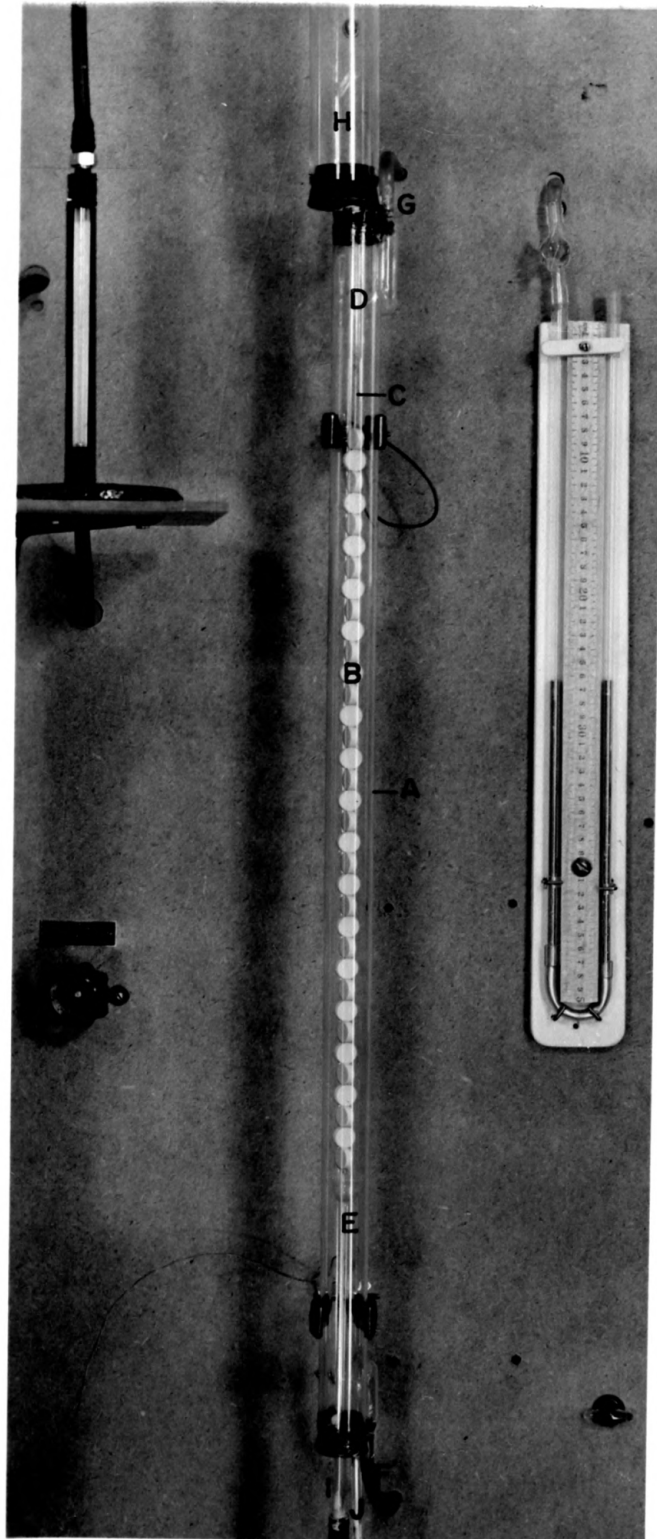

EXPLANATION OF PLATE VI

Close-up view of the Packed Column

- A: 2" glass pipe
- B: Glass Raschig rings
- C: Perforated stainless steel plate,
rings support
- D: Stainless steel tube, stainless
steel plate support
- E: Tygon inlet liquid distributor
- F: Liquid outlet

PLATE VI

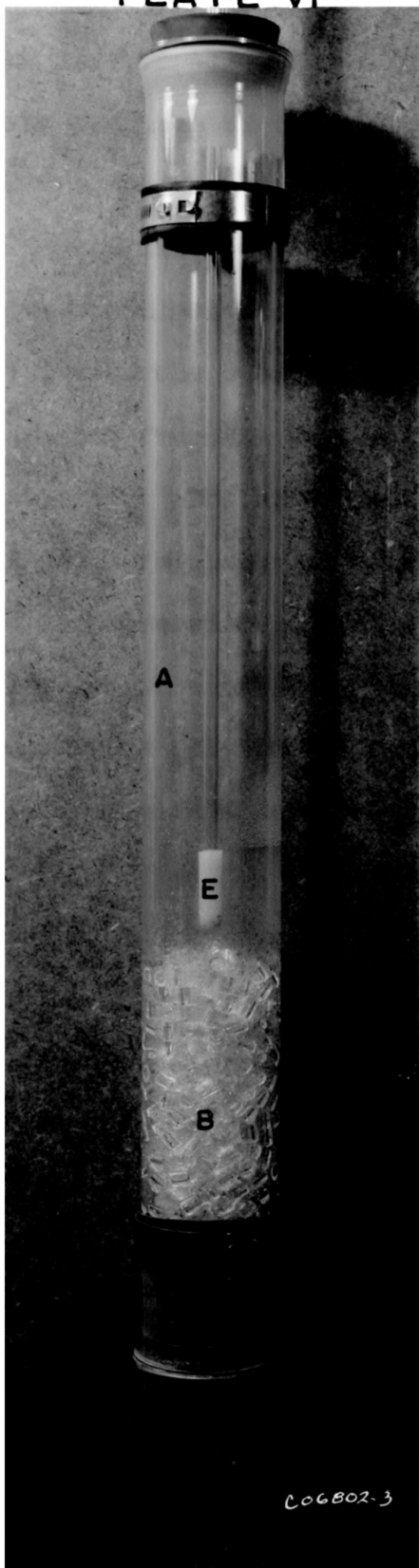

the plate and the bottom of the column was one inch. The total height of the packed section was 6 inches. The entering liquid was sprinkled over the top of the packed portion through a short piece of Tygon tubing which had small holes bored through the side and the end.

In all runs the liquid was stored in a 50-gallon stainless steel tank. It was pumped by a 1/30 horsepower stainless steel centrifugal pump through a Fisher and Porter C-Clamp Florator into the operating column. In each column, liquid entered at the top and came out from the bottom, while the gas entered at the bottom and came out from the top. The effluent liquid was conducted through a Tygon tube to a liquid level regulator as shown on Plates I and II. Liquid sample was drawn from the level regulator into a 300-ml. B.O.D. (Biological Oxygen Demand) bottle (1). The entering liquid used was distilled water or dilute (0.075 N) sodium sulfite solution. In the latter case, the liquid surface in the tank was covered with a layer of paraffin oil to keep it from the atmospheric oxygen.

Cylinder oxygen was metered with a Brooks rotameter. It was saturated with water before entering the column. It exhausted into open atmosphere.

Pressure and temperature measurements were made by means of water filled manometers and mercury thermometers respectively, as shown on Plates I and II.

Operating Procedure

The usual procedure was as follows:

1. The walls in the wetted wall column, the discs in the disc column and the Raschig rings in the packed column were carefully wetted. Dry spots in the wetted wall column could be removed by tapping or shaking the supporting rods. In case of the disc and packed columns, the columns were flooded and drained before introducing the gas.

2. Liquid and gas rates were adjusted to the desired levels by means of the needle valve and the cylinder top regulator, respectively.

3. The liquid level inside the column was adjusted by lowering or raising the liquid level regulator so that: a) the liquid would fill the receiving funnel as high as possible without causing an overflow in case of the disc column. b) the liquid would fill out all the free space at the bottom of the column to displace all oxygen bubbles, in the case of the wetted wall column. Of course, the liquid level must never be so high as to overflow into the gas line. c) the liquid in the packed column should be just above the bottom of the column.

4. It was sometimes desired to adjust the partial pressure of the oxygen inside the column to approach a predetermined value in order to make the driving force of different runs nearly equal. This was best done before fixing the liquid level by regulating the outlet gas opening until the desired manometer reading was reached. The proper manometer reading was calculated as follows:

$$M = \left[p_{O_2} - (P - p_{H_2O}) \right] \times 13.6$$

where:

M = the desired manometer reading (mm. H₂O)

p_{O₂} = the desired partial pressure of oxygen (mm Hg)

P = Barometer reading (mm Hg)

p_{H₂O} = Saturated vapor pressure of water corresponding to the inlet gas temperature (at the outlet of the saturator) mm Hg.

5. The thermometers and the manometers readings were recorded each time the sample was taken. The average of these, if there were any slight variations, was used in the calculation.

6. The liquid outlet sample was drawn from the liquid level regulator and collected in the B.O.D. sampling bottle. During the sampling the quantity drawn should not effect the liquid level within the level regulator. The sampling was done after the content in the bottle had been replaced at least two or three times. There must not be any entrainments of air or gas bubbles. Then the sampling line was closed and the sampling bottle stoppered. A similar precaution was required for the sampling of the inlet liquid; in addition, it was necessary to readjust the liquid flow-rate before and after opening the inlet liquid sampling stopcock.

Materials

Preparation of Na_2SO_3 solution: Fisher Certified Reagent Sodium Sulfite was used to prepare the required solution. A concentrated solution (180 g/liter) was prepared first and then diluted to about 0.075N in a storage tank. A layer of paraffin oil was used as a floating cover to prevent the oxidation of the solution by the atmospheric oxygen. After thorough mixing, the solution was ready for use.

Oxygen: U.S.P. Oxygen produced by National Cylinder Gas Co. was used.

Distilled water: City water was distilled in a Stokes still.

Chemical Analysis

Oxygen in water: The oxygen in the liquid was determined by the Winkler method (1). The principle of this method is that mangalous sulfate will absorb oxygen in the presence of concentrated sodium hydroxide solution to form manganese hydroxide. When this mixture is acidified with concentrated sulfuric acid in the presence of excess iodide, free iodine is liberated and

the amount of iodine liberated is proportional to the oxygen absorbed by the manganous sulfate. The iodine is then titrated by sodium thiosulfate using starch solution as an indicator. The reactions involved are as follows:

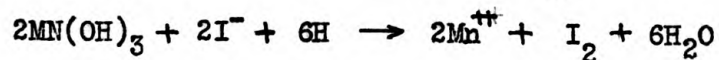
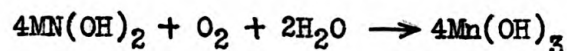
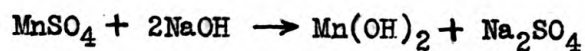

The reagents used are as follows:

1. MnSO_4 Solution: 480-g $\text{MnSO}_4 \cdot 4\text{H}_2\text{O}$ was dissolved in distilled water and diluted to 1 liter. The solution should liberate no more than traces of iodine when added to an acidified solution of potassium iodide. This would indicate the absence of manganic and ferric salts.

2. Alkaline-potassium iodide solution: 500-g NaOH and 150-g KI was dissolved in 1 liter of distilled water. The reagent should be practically free from carbonates. It should not give any color with starch when diluted and acidified.

3. Concentrated sulfuric acid: Specific gravity 1.83 to 1.84, about 36 N.

Laboratory procedure. 1. Upon removing the glass stopper from the sampling bottle, first 2-ml of MnSO_4 solution and then 2-ml of alkaline-iodide solution were added at once well below the surface of the liquid. The bottle was stoppered as promptly as possible even at the sacrifice of displacing some water (about 4 ml) by the glass stopper in the process. In order to expel all of the air in the bottle this technique was found necessary.

2. The stoppered sample was agitated by a magnetic stirrer. The mag-

netic stirring bar was placed in the bottle and remained there during the calibration and sampling.

3. After complete mixing, about one minute, and settling, 2-ml of concentrated H_2SO_4 were added along the edge of the bottle-neck, and the sample was mixed again.

4. 25-ml of the well mixed sample were transferred into a 250-ml Erlenmeyer flask, and titrated with 0.1 N sodium thiosulfate solution through a micro burette.

Oxygen Absorbed in Sulfite Solution. The amount of oxygen absorbed in the sulfite solution was calculated by taking the difference between the sulfite content of the liquid samples taken at the inlet and the outlet of the column, respectively. The sample was added into a 250-ml Erlenmeyer flask which contained 25-ml of 0.1 N iodine solution, and the excess iodine was titrated by 0.1 N sodium thiosulfate solution. Both 0.1 N standard solutions were prepared and standardized according to the procedures in "A Text Book of Quantitative Inorganic Analysis Theory and Practice" by Arthur I. Vogel (23).

RESULTS AND DISCUSSION

Summary of Data

The absorption of oxygen into water was studied in a total of nine runs with the three different columns. Each column was operated at three different liquid rates: 13.2 lb./hr., 23.5 lb./hr., and 36.2 lb./hr. The gas (oxygen) rate was kept constant at 4.57 cu. ft./hr. in all nine runs.

Another 12 runs were made for the absorption of oxygen into sulfite solution in the three columns operating at the same flow rates as in the O_2 -

water runs.

The liquid temperature range was from 21.0°C to 29.7°C. The gas temperature range was from 21.7°C to 31.0°C. The partial pressures of oxygen were adjusted to about 742.5 mm Hg. The data obtained are shown in Tables 1 and 2.

Prior to these runs with the three columns in parallel, 42 runs of oxygen-sulfite system had been made in the disc column alone to investigate the effects of the amount of catalyst, liquid rate, gas rate and liquid concentration.

Discussion

The results of these experiments are shown on Plates VII, VIII, and IX. On these plates, k_L , with and without chemical reaction, are plotted against liquid flow rate. For the absorption of oxygen in water, k_L increases with the increasing liquid rate. The explanation is that in this system, the liquid film resistance is predominant in controlling the absorption rate. As the liquid rate is increased, the liquid stream becomes more turbulent and offers less resistance to mass transfer, hence higher absorption rate results.

In the absorption of oxygen into sulfite solution, the results of the disc column show that k_L increases with the increasing liquid rate, and it is always greater than k_L of the physical absorption of oxygen into water. However, the present data are inconclusive for the wetted wall and packed columns. The reproducibility of the repeated runs is shown in Table 3. In this table, the k_L values have not been corrected for temperature variations. The effects of the variations in partial pressure of oxygen (p_{O_2}), in liquid feed composition (C'_{in}), and in temperature, respectively, are considered in tern as follows:

Table 1. Liquid Film coefficient, absorption of oxygen in water and in sulfite solution, wetted wall and disc column.

Run No.:	Liquid Rate lb./hr.:	Liquid Temp. °C inlet : outlet:	C^i , (lb. of O_2 /cu.ft.) $\times 10^4$ inlet : outlet:	O_2 absorbed (lb. of O_2 /hr.) $\times 10^5$	Partial pressure of oxygen in column (atm.)	C^o (lb. of O_2 /cu.ft.) $\times 10^2$ inlet : outlet:	$(\Delta C^i)_{l.m.}$ $\times 10^2$	k_L	k_L corrected to 20°C
WW-5	13.2	25.0 : 24.2	5.30 : 9.54	8.99	0.9568	2.417 : 2.452	2.41	0.69	0.62
WW-7	23.5	21.0 : 21.0	5.69 : 8.95	12.3	0.9531	2.575 : 2.575	2.48	0.92	0.90
WW-10	36.2	21.4 : 21.0	5.69 : 8.21	14.6	0.9527	2.561 : 2.574	2.50	1.08	1.05
DW-5	13.2	24.5 : 24.0	5.68 : 16.46	22.8	0.9543	2.434 : 2.451	2.33	0.45	0.40
DW-7	23.5	22.7 : 22.6	5.69 : 15.05	35.3	0.9564	2.516 : 2.516	2.42	0.66	0.62
DW-10	36.2	22.9 : 22.9	5.69 : 15.33	56.0	0.9520	2.498 : 2.498	2.39	1.07	0.99
			(lb. of SO_3 =/cu.ft.) $\times 10$				$(\Delta C^i)_{avg.}$	k_L^i	k_L^i corrected to 20°C
WS-5-1	13.2	26.8 : 26.0	2.041 : 2.014	11.5	0.9489	2.333 : 2.359	2.35	0.91	0.78
WS-5-2	13.2	26.6 : 26.1	2.037 : 2.006	13.1	0.9499	2.341 : 2.356	2.35	1.03	0.90
WS-7	23.5	26.6 : 26.1	2.037 : 2.020	12.9	0.9499	2.341 : 2.356	2.35	1.02	0.88
WS-10	36.2	25.0 : 24.9	2.037 : 2.027	11.6	0.9545	2.411 : 2.442	2.43	0.89	0.79
DS-5	13.2	26.9 : 26.6	2.116 : 2.034	35.2	0.9520	2.335 : 2.345	2.35	0.68	0.59
DS-7	23.5	26.2 : 26.2	2.116 : 2.048	51.4	0.9520	2.362 : 2.362	2.36	0.99	0.86
DS-10-1	36.2	24.5 : 24.5	2.273 : 2.193	93.0	0.9516	2.427 : 2.427	2.43	1.74	1.58
DS-10-2	36.2	24.9 : 24.7	2.115 : 2.049	76.8	0.9443	2.391 : 2.403	2.39	1.46	1.30

Table 2. Liquid film coefficient, absorption of oxygen in water and sulfite solution, packed column.

Run No.	Liquid Rate		Liquid temp. °C		C', (lb. of O ₂ /cu.ft.)x10 ⁴		O ₂ Absorbed (lb. of O ₂ /hr)x10 ⁵	Partial pressure: C' _e , (lb. of O ₂ /cu.ft.)x10 ²		G	L	(1 - $\frac{L}{mG}$)h	L x ln $\frac{(C'_{e0} - C'_1)}{(C'_{e1} - C'_0)}$	k _L a	k _L a corrected to 20°C	
	lb./hr.	inlet	outlet	inlet	outlet	inlet		outlet	Column (atm.)							inlet
PW-5	13.2	25.8	25.5	5.30	16.44	23.6	0.9541	0.9535	2.383	2.387	17.7	605	0.494	30.3	0.99	0.87
PW-7	23.5	24.5	24.3	5.30	15.46	38.4	0.9578	0.9566	2.443	2.450	17.7	1077	0.488	50.1	1.65	1.49
PW-10	36.2	22.0	22.0	5.69	14.42	52.2	0.9523	0.9515	2.535	2.533	17.7	1659	0.481	57.9	1.93	1.84
				(lb. of SO ₃ ²⁻ /cu.ft.) x10									hA(C' _e) _{avg} x 10 ³		k _L a	k _L a corrected to 20°C
PS-5-1	13.2	29.6	29.7	2.117	1.915	86.1	0.9521	0.9514	2.239	2.223			2.437		3.53	2.83
PS-5-2	13.2	26.3	25.9	2.040	1.815	80.6	0.9494	0.9480	2.350	2.362			2.568		3.14	2.73
PS-7	23.5	25.5	25.1	2.349	2.263	65.0	0.9570	0.9559	2.396	2.343			2.582		2.52	2.24
PS-10	36.2	26.0	25.8	2.351	2.269	95.5	0.9559	0.9553	2.376	2.385			2.595		3.68	3.20

EXPLANATION OF PLATE VII

Effect of Liquid Rate on Liquid Film Coefficient in the Wetted-wall column

Ordinate: Liquid film coefficient, k_L , lb./hr.(sq.ft.)(lb./cu.ft.)

Abscissa: Liquid rate, lb./hr.

Legend: ○ : Absorption of oxygen in water.

⊙ : Absorption of oxygen in sulfite solution.

PLATE VII

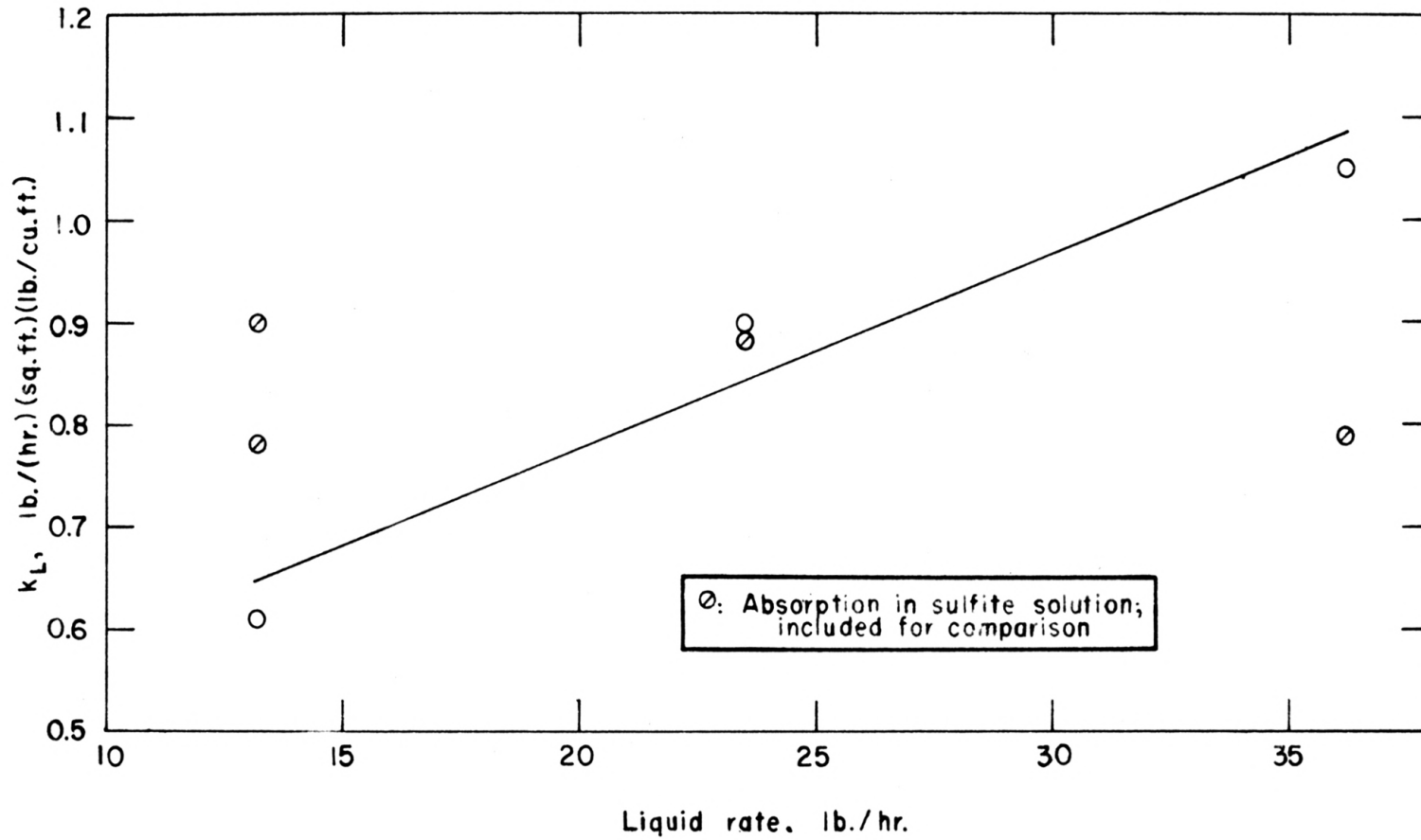

EXPLANATION OF PLATE VIII

Effect of Liquid Rate on Liquid Film Coefficient in the Disc Column

Ordinate: Liquid film coefficient, k_L lb./hr.)(sq. ft.)(lb./cu.ft.)

Abscissa: Liquid rate lb./hr.

Legend: ○ : Absorption of oxygen in water

⊙ : Absorption of oxygen in sulfite solution

PLATE VIII

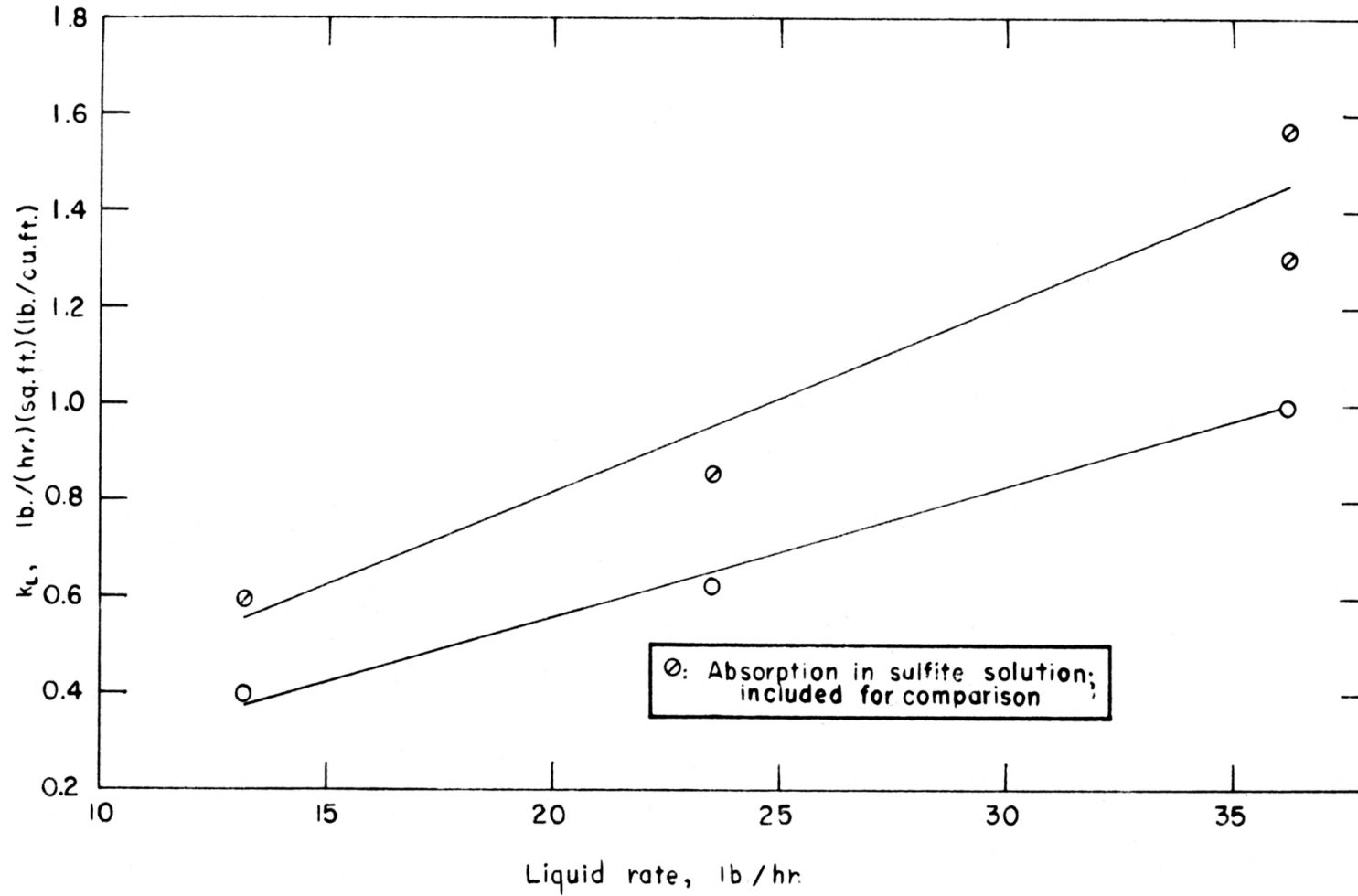

EXPLANATION OF PLATE IX

Effect of Liquid Rate on Liquid Film Coefficient in the Packed Column

Ordinate: Liquid film coefficient, $k_L A$, lb./hr. (cu.ft.)

Abscissa: Liquid rate, lb./hr.

Legend: ○ : Absorption of oxygen in water.

⊙ : Absorption of oxygen in sulfite solution.

PLATE IX

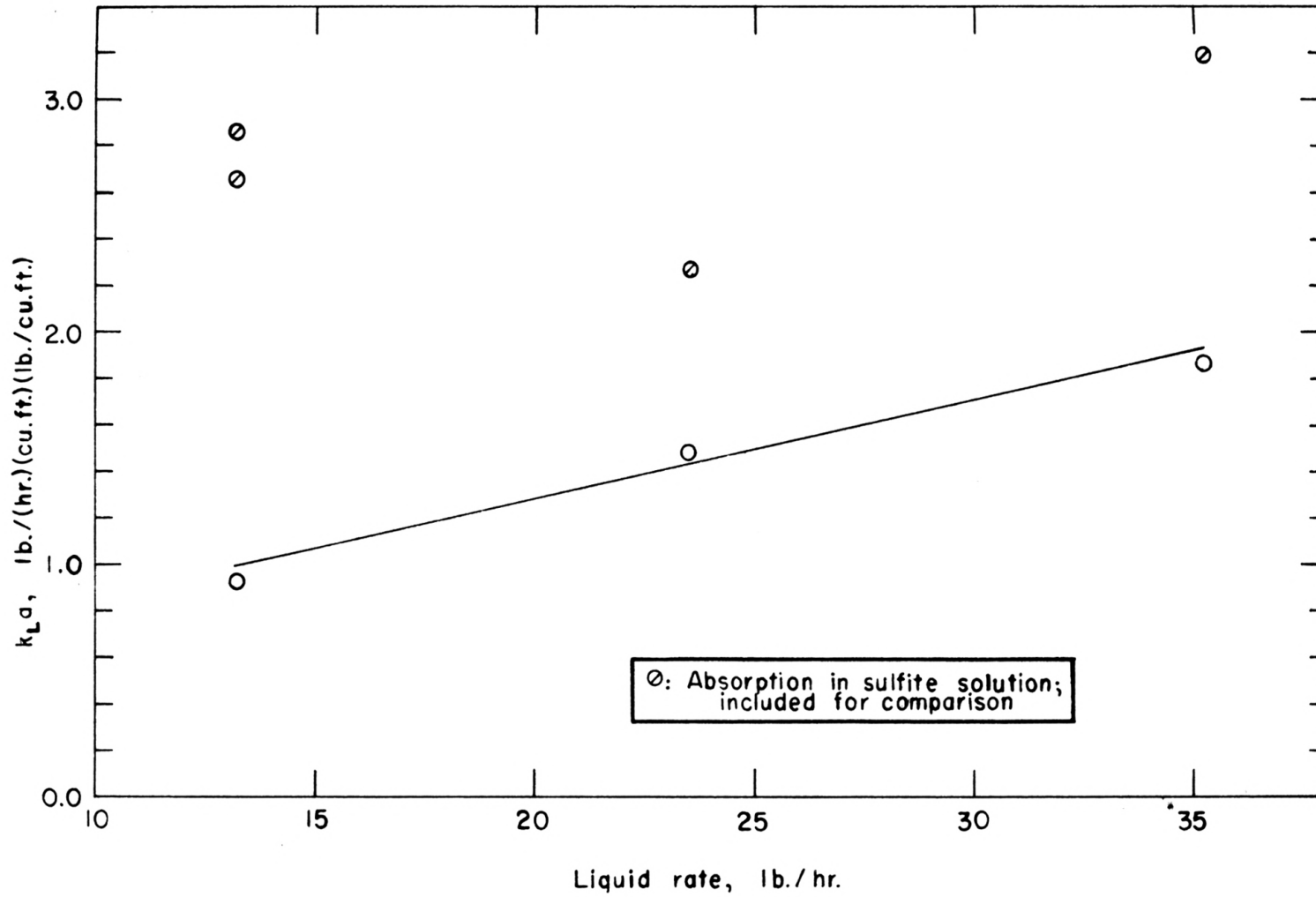

Table 3. Average Deviations in the Repeated Runs, Absorption of O₂ in Sulfite Solution.

Run	Liquid Temp. °C		Δt(°C)		P _{O₂}		ΔP _{O₂}		C _{in} ⁱ	ΔC _{in} ⁱ	k _L ⁱ	Δk _L ⁱ
No.	inlet	outlet	inlet	outlet	inlet	outlet	inlet	outlet	:	:	or	or
	:	:	:	:	:	:	:	:	:	:	k _L ⁱ _a	Δk _L ⁱ _a
WS-5-1	26.8	26.0			0.9489				0.2041		1.033	
			0.2	0.1			± 0.1%			± 0.2%		±12.9%
WS-5-2	26.6	26.1			0.9499				0.2037		0.908	
DS-10-1	24.5	24.5			0.9516				0.2273		1.742	
			0.4	0.2			± 0.8%			± 7.2%		±17.9%
DS-10-2	24.9	24.7			0.9443				0.2115		1.456	
PS-5-1	29.6	29.7			0.9521	0.9514			0.2117		3.53	
			3.3	3.8			± 0.3% ± 0.4%			± 3.7%		±11.7%
PS-5-2	26.3	25.9			0.9494	0.9480			0.2040		2.14	

C_{in}ⁱ = liquid feed composition, lb./cu. ft.

Partial Pressure of Oxygen: In the mass transfer rate equation, the partial pressure of oxygen appears in the driving force term. Therefore, P_{O_2} should have no effect on the computed values of k_L in Table 3. Then the deviations as shown in Table 3 are probably the combined effect of liquid feed composition and the temperature.

Liquid Feed Composition: Fuller and Crist (9) showed that if the chemical is pure or the amount of the positive and negative catalyst were fixed, the reaction rate, and consequently the liquid film coefficient, would be independent of the sulfite concentration in the solution. They also showed that reaction rate increased with the increasing amount of catalyst. If the combined effect of the impurities in the sulfite used was that of a positive catalyst, then the reaction rate and the film coefficient would be higher for the more concentrated feed composition.

Temperature: The effect of temperature depends upon whether there is unreacted dissolved oxygen in the liquid. If there is no unreacted dissolved oxygen, k_L would increase with temperature since the reaction rate increases with temperature (3).

If there is also unreacted dissolved oxygen present then another factor should be considered, that is, the Henry's law constant, H , in atmosphere per concentration unit. Higher the temperature is, the more equilibrium back pressure the solution exerts, hence H would become larger and the computed value of k_L would become smaller at the higher temperature. Therefore, the observed effect would be a composite of two opposing effects; one tends to increase k_L , the other tends to reduce it. The data in Table 3 indicate that such could have been the case. The result of a subsequent test shown on the next pages gave further evidence of the presence of dissolved but unreacted

oxygen.

The magnitude of the deviations of the present data, large as it is, is within the range of similar work reported in the literature: Cooper, et al, (3) up to 45 per cent; Stephens and Morris, up to 25 per cent (18). This merely points out the difficult nature of this type of experiment. The immediate objective in the future work would be to improve the precision of measurements.

Two extreme cases were found in the literature in regard to the purity of the chemicals used in the oxygen-sulfite system. Fuller and Crist (9) showed that this system was so sensitive to the positive and the negative catalysts that the use of rubber stoppers would introduce uncertainty in the results. Not only the sulfite used should be carefully refined, the water should also be double distilled and stored in a special container and should not be kept longer than three hours. With these precautions, the observed reaction velocity did not change even though the sulfite concentration changed five fold. On the other hand, tap water, "cleaned" laboratory compressed air, "c.p." sodium sulfite, and "c.p." cupric sulfate were used by Cooper, et al. (3), resulting in a maximum deviation of about 45 per cent.

For further investigation, the question whether the effluent solution from a column contains unreacted molecular oxygen or not, should be resolved first. The method of chemical analysis used in the published work (3)(9) can not answer this question.

A test has been made to check the assumption that all the dissolved molecular oxygen would have reacted completely with the sulfite by the time the effluent liquid samples were collected and analyzed. The test was carried out in two parts. First, a quantity of oxygen enriched water was prepared by

bubbling oxygen slowly through distilled water. It was then poured into a 2-liter Erlenmeyer flask to mix with a known excess amount of sulfite solution by means of a magnetic stirrer. A layer of paraffin oil was used to seal the liquid from atmospheric oxygen during mixing and storage.

Then, 25-ml samples were siphoned off, at various time intervals, into a flask containing 25-ml 0.1 N iodine solution. The excess iodine was then back titrated with 0.1 N sodium thiosulfate solution to determine the sulfite content present in the sample. The result is plotted on the following graph.

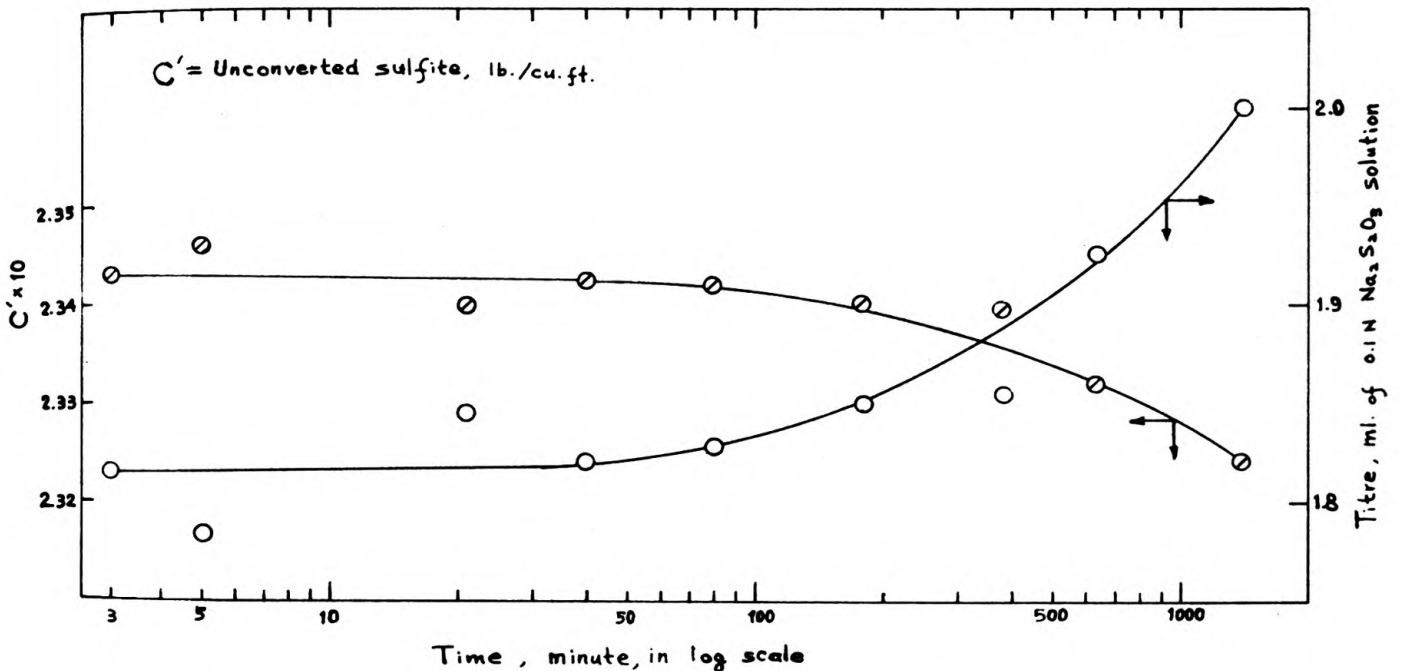

It shows that the sulfite content in the oil-sealed solution decreased gradually with time. However, the test period was much longer than the time involved in the regular absorption runs. Therefore, this time factor could not have affected the chemical analysis data seriously.

In the second part of the test the oxygen enriched water was prepared as

before. Three identical samples were drawn and stored in the B.O.D. (Biological Oxygen Demand) sampling bottles. Sample No. 1 was analyzed by Winkler's method directly for its total oxygen content. 25-ml of sample No. 2 and 3 were transferred with a pipette into the Erlenmeyer flasks containing weighed excess amount of sodium sulfite powder. The flasks were swirled gently and as soon as the sulfite had been completely dissolved, 25-ml of 0.1 N iodine solution were added to each flask. The excess iodine was then back titrated with 0.1 N sodium thiosulfate solution to determine the amount of unconverted sulfite present. The difference between the initial sulfite content and the unconverted sulfite should be equivalent to the oxygen consumed. The following results were obtained:

Total oxygen content by Winkler's Method: 28.9 ppm.

Oxygen consumed by Iodine back titration: 12.4 ppm.

In other words, the iodine method of analysis reported only about 50 per cent of the total amount of oxygen absorbed. This would explain why the k_L value for the oxygen-sulfite system was lower than that of the oxygen-water system in some cases.

The systematic error arising from the method of analysis itself requires further confirmation. Then the k_L values should be corrected accordingly.

Table 4 shows the effect of catalyst in the absorption of oxygen in sulfite solution at two sulfite concentration levels. It should be noted that although the absorption rate is reported as lb. of oxygen/hr., actually the chemical analysis procedure used only indicate the amount of absorbed oxygen that has been consumed in oxidizing sulfite to sulfate. Therefore, the data represent the effect of catalyst on reaction rate and not the overall absorption rate of molecular oxygen.

Table 4. Effect of catalyst concentration on the rate of absorption of oxygen in sulfite solution.

Run No.	Catalyst concentration x10 ⁴ m of CuSO ₄	O ₂ Absorbed (lb./hr.)x10 ⁵	Liq. conctn. lb./hr.	Liquid rate lb./hr.	Gas Rate cu.ft./hr.
D-1	No	51.5	0.185	4.24	5.62
B-1N	10	24.7	0.178	"	"
D-2	No	55.8	0.184	6.85	"
B-2N	10	27.3	0.178	"	"
B-0	No	51.9	0.189	9.82	"
B-0 ¹	No	55.0	0.174	"	"
B-5	1	34.7	0.165	"	"
B-4	5	39.5	0.177	"	"
B-3N	10	29.1	0.180	"	"
D-3	No	46.1	0.115	16.9	"
B-4N	10	50.0	0.178	"	"
D-4	No	141.8	0.115	24.8	"
B-5N	10	59.8	0.178	"	"
C-C _a	No	56.3	0.188	9.82	16.31
C-0 _a ¹	No	139.0	0.184	"	"
C-4 _a	0.5	40.1	0.177	"	"
C-5 _a	1	42.9	0.165	"	"
F-1	No	50.5	0.978	4.24	5.62
E-1	10	51.7	1.087	4.24	5.62
F-2	No	43.3	1.132	9.82	5.62
E-2	10	54.9	1.087	9.82	5.62
F-3	No	71.8	1.131	38.6	5.62
E-3	10	118.0	0.839	38.6	5.62

At the lower level, (0.115 to 0.189 lb. of $\text{SO}_2^-/\text{cu. ft.}$), the presence of catalyst (cupric sulfate) reduced the absorption rate by about 50 per cent. At the higher level (0.839 to 1.132 lb. of $\text{SO}_2^-/\text{cu. ft.}$), the presence of catalyst increased the rate slightly. This anomaly may be attributed to the composite catalytic effect of the impurities present in the cupric sulfate, sodium sulfite and water. The positive and negative catalytic effect of various possible impurities were also observed and discussed by Fuller and Crist (9) and others (15). However, further study of the reaction kinetics itself without the complication of the absorption mechanism is needed in order to arrive at a more rational explanation.

CONCLUSIONS

The results of the present work are summarized as follows:

1. A short wetted-wall column and a glass Raschig ring column have been constructed. The operating procedure has been established. Together with the disc column, these three constitute a series of gas absorption apparatus of progressing complexity in flow pattern.
2. The absorption of oxygen in water has been studied in the three columns as a test system for physical absorption. The results are in agreement with the theoretical prediction in that the absorption rate and the mass transfer coefficient are independent of gas flow rate but increase with the liquid flow rate. (Plates VII, VIII, and IX).
3. The absorption of oxygen in aqueous solution of sodium sulfite was studied in the disc column. The ratio of k_L' , the liquid film co-

efficient in this case, and k_L , the liquid film coefficient of the oxygen-water data, appears to be constant. (Plate VIII).

4. The absorption data obtained from the wetted-wall column and the packed column do not reveal any simple relationship between k_L' and k_L . The uncertainty of the data is attributed to the method of chemical analysis used. Preliminary tests showed that only a part of the total oxygen dissolved had reacted with sulfite and was accounted for by the analysis.
5. The catalytic effect of cupric sulfate upon the absorption rate of oxygen in sulfite solution has been studied in the disc column at various sulfite concentrations. At the higher concentration level, the rate is increased by the catalyst. However, a reversal of this trend takes place at the lower concentration (Table 4).
6. It is believed that on the basis of a critical review of the current theories on the kinetics of gas absorption, the experimental procedure established in the present work offers the most direct approach to the problem of finding a correlation useful for design purposes. The present data are insufficient for general correlation mainly because of the complexity in the chemical reaction kinetics of the test system. In the next stage of the investigation, the catalytic effect of possible impurities present in the system should be reexamined and the method of chemical analysis refined.

ACKNOWLEDGMENTS

The author wishes to express his gratitude to the Kansas State College Engineering Experiment Station for the financial assistance which made this research possible, and to:

Drs. S. L. Wang and Henry T. Ward for their advice and encouragement during the course of this work.

BIBLIOGRAPHY

- (1) American Public Health Association.
Standard method for examination of water and sewage, p. 107, 124-128.
- (2) Churchill, R. V.
Modern operational mathematics in engineering, pp. 85, 294-302, New York: McGraw-Hill Co., 1944.
- (3) Cooper, C. M., G. A. Fernstrom and S. A. Miller.
Performance of agitated gas-liquid contactors. Ind. Eng. Chem. 36: 504, 1944.
- (4) Danckwerts, P. V.
Gas absorption accompanied by chemical reaction. Am. Inst. of Chem. Eng. Journal, Vol. 7, No. 4, pp. 456-462, 1955.
- (5) Danckwerts, P. V.
Significance of liquid-film coefficients in gas absorption. Ind. Eng. Chem. 43: 1462, 1951.
- (6) Danckwerts, P. V. and A. M. Kennedy.
Kinetics of liquid-film process in gas absorption. Trans. of the Inst. of Chem. Engineers. Symposium on gas absorption. 32: supplement No. 1, S50, 1954.
- (7) Emmert, R. E. and R. L. Pigford.
Absorption and desorption of slightly soluble gases in falling liquid films. Chem. Eng. Progr. 50: 87, 1954.
- (8) Friedman, S. J. and C. O. Miller.
Liquid films in the viscous flow region. Ind. Eng. Chem. 33: 885, 1941.
- (9) Fuller, E. C. and R. H. Crist.
The rate of oxidation of sulfite ions by oxygen. Am. Chem. Soc. Journal 63: 1644, 1941.
- (10) Gallagher, J. B.
Effect of mixing on the air oxidation of sodium sulfite solution. Unpublished M.S. thesis, Illinois Institute of Technology, 1954.
- (11) Higbie, R.
The rate of absorption of pure gas into a still liquid during short periods of exposure. Trans. Am. Inst. Chem. Engr. 31: 365, 1935.
- (12) Hwu, C. K.
Absorption with chemical reaction. M. S. thesis, Kansas State College, 1954.

- (13) Lewis, W. K. and W. G. Whiteman.
Principles of gas absorption. Ind. Eng. Chem. 16: 1215-20, 1924.
- (14) Lynn, S., Straatemeier, and H. Kramers.
Absorption studies in the light of the penetration theory. Chem. Eng. Science, Vol. 4, No. 2, April, pp. 49-67, 1955.
- (15) Mellor, J. W.
A comprehensive treatise on inorganic and theoretical chemistry. Vol. X, pp. 263-265, New York, Longmans, Green and Co., 1930.
- (16) Sherwood, T. K. and F. A. L. Holloway.
Performance of packed towers--liquid film data for several packings. Trans. Am. Inst. Chem. Eng. 36: 39, 1940.
- (17) Sherwood, T. K. and R. L. Pigford.
Absorption and extraction. P. 129, New York: McGraw-Hill Co., 1952.
- (18) Stephens, E. J. and G. A. Morris.
Determination of liquid-film absorption coefficients. Chem. Eng. Prog. 47: 235, Fig. 3, 1951.
- (19) Tien, C.
Absorption with chemical reaction. M. S. thesis, Kansas State College, 1954.
- (20) Vogel, Arthur I.
A text book of quantitative inorganic analysis theory and practice. PP. 334, 339-340, 343, 2nd ed. New York: Longmans, Green, 1951.

APPENDIX

Differential Equations in the Penetration Theory

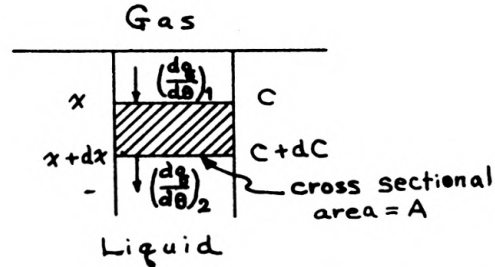

Consider a differential element of thickness dx and cross sectional area

A in the liquid layer as shown above where

$$\left(\frac{dg}{d\theta}\right)_1 = -DA \left(\frac{\partial C}{\partial x}\right) \quad (a)$$

$$\left(\frac{dg}{d\theta}\right)_2 = -DA \left[\left(\frac{\partial C}{\partial x}\right) + \frac{\partial}{\partial x} \left(\frac{\partial C}{\partial x}\right) dx \right] \quad (b)$$

During the time interval $d\theta$, the change in the amount of diffusing material

is $\left(\frac{\partial C}{\partial \theta}\right) A dx$. A material balance over the element during $d\theta$ shows that

$$\left(\frac{dg}{d\theta}\right)_1 d\theta - \left(\frac{dg}{d\theta}\right)_2 d\theta = A \left(\frac{\partial C}{\partial \theta}\right) dx d\theta \quad (c)$$

or

$$-DA \left(\frac{\partial C}{\partial x}\right) + DA \left[\left(\frac{\partial C}{\partial x}\right) + \left(\frac{\partial^2 C}{\partial x^2}\right) dx \right] = A \left(\frac{\partial C}{\partial \theta}\right) dx \quad (d)$$

i.e.

$$\left(\frac{\partial C}{\partial \theta}\right) = D \left(\frac{\partial^2 C}{\partial x^2}\right) \quad (e)$$

Boundary conditions:

$$C = C_0 \quad \text{at } \theta = 0 \quad x > 0$$

$$C = C_i \quad \text{at } \theta > 0 \quad x = 0$$

$$C = C_0 \quad \text{at } \theta > 0 \quad x = \infty$$

$$C = C_i \quad \text{at } \theta = \infty \quad x > 0$$

Let $C = F(x, \theta)$ $C_0 = F(x, 0)$

$$\frac{\partial C}{\partial \theta} = F_\theta(x, \theta)$$

$$\frac{\partial^2 C}{\partial x^2} = F_{xx}(x, \theta)$$

Also Let $L\{F(x, \theta)\} = f(x, s)$

from the Laplace transform table (2),

$$L\{F_\theta(x, \theta)\} = sf(x, s) - F(x, 0) = sf(x, s) - C_0$$

and $L\{F_{xx}(x, \theta)\} = f_{xx}(x, s)$

The transform of (e) is:

$$sf(x, s) - C_0 = Df_{xx}(x, s)$$

or $f_{xx}(x, s) - \frac{s}{D}f(x, s) = -\frac{C_0}{D}$

i.e. $\frac{d^2}{dx^2}f(x, s) - \frac{s}{D}f(x, s) = -\frac{C_0}{D}$ (f)

Now, equation (f) is in the form of an ordinary differential equation of second order and with constant coefficients. It is solved as follows:

(1) The complementary solution:

$$\frac{d^2}{dx^2}f(x, s) - \frac{s}{D}f(x, s) = 0 \quad (m = \pm\sqrt{\frac{s}{D}})$$

$$f(x, s) = k_1 e^{-\sqrt{\frac{s}{D}}x} + k_2 e^{+\sqrt{\frac{s}{D}}x}$$

(2) The particular solution:

let $f(x, s) = K$ (g)

then $\frac{d}{dx}f(x, s) = \frac{d^2}{dx^2}f(x, s) = 0$ (h)

Substituting (g) and (h) into (f) get:

$$-\frac{s}{D}K = -\frac{C_0}{D} \quad \text{or} \quad K = \frac{C_0}{s}$$

(3) The general solution:

$$f(x, s) = k_1 e^{-\sqrt{\frac{s}{D}}x} + k_2 e^{+\sqrt{\frac{s}{D}}x} + \frac{C_0}{s} \quad (i)$$

(4) Evaluation of arbitrary constants, k_1 and k_2 :

At $x = \infty$ $C = C_0$ and $f(x, s) = \frac{C_0}{s}$

k_2 in (i) must be zero and (i) becomes,

$$f(x,s) = k_1 e^{-\sqrt{\frac{s}{D}}x} + \frac{C_0}{s} \quad (j)$$

At $x = 0$ $C = C_i$ and $f(x,s) = \frac{C_i}{s}$

therefore, $\frac{C_i}{s} = k_1 + \frac{C_0}{s}$

i.e. $k_1 = \frac{C_i - C_0}{s}$

therefore, $f(x,s) = \frac{C_0}{s} + \frac{C_i - C_0}{s} e^{-\sqrt{\frac{s}{D}}x}$ (k)

The inverse transform of (k) is found to be (2)

$$F(x,\theta) = C = C_0 + (C_i - C_0) \operatorname{erfc} \left(\frac{x}{2\sqrt{D\theta}} \right)$$

$$C = C_0 + \frac{C_i - C_0}{\sqrt{D\theta\pi}} \int_x^\infty e^{-\frac{x^2}{4D\theta}} dx \quad (1)$$

Note that all the present theories assume that the gas-liquid equilibrium is maintained at the interface. Therefore, $C_i = C_e$ where C_e is the equilibrium concentration corresponding to the partial pressure in the bulk of the gas phase.

The Age Distribution Concept

For illustration, an analogy can be drawn between an absorbing surface and the human population. Let us consider the age distribution among the residents in the state of Kansas. The following observations can be made:

1. The number of persons between the age of 20 to 25 would certainly be different from the number between 90 and 91. Thus the size of any age group depends on the age level $\phi(\theta)$ (whether it is in the 20's or 90's) and the breadth of the interval $d\theta$ (whether it is 5 years or 1 year). Mathematically, one writes

[The size of age group between θ to $(\theta + d\theta)$] = $\phi(\theta) d\theta$

2. Assuming that during a relatively short period, say, one year, the age distribution and the total number of the population remain unchanged: Consider two adjacent age groups, say (1), $(\theta - d\theta)$ to θ , or, 28 to 30 and (2), θ to $(\theta + d\theta)$, or, 30 to 32. Then, during this one year the number of persons growing out of group (1) and into group (2) must be the same as the number in group (2), or, 30 to 32 years old, existing at any time, which is, $\phi(30) d\theta$.

3. But how many are growing out of group (1)? This must be equal to the existing number in group (1) less those who have died during the mean time. Mathematically, this number would be $\phi(28) d\theta - [\phi(28)d\theta] S d\theta$ where "S" is the mean fractional rate of production, or, the birth rate, expressed as fraction of existing population per year. "S" must be also the same as death rate, since the total population remains unchanged.

4. Combining 2 and 3 above, we have, $\phi(30) d\theta = \phi(28) d\theta (1 - S d\theta)$ or, in general, $\phi(\theta) d\theta = \phi(\theta - d\theta) d\theta (1 - S d\theta)$
This is equation (11).

5. The only unrealistic thing about this analogy is the assumption that "S" has equal value for all age groups. Naturally, people in their 20's just do not pass away at the same rate as those in their 90's. However, it is reasonable to assume that all the elements of a liquid surface do have the same chance of being renewed.

Principal Constants of Disc Column

number of discs	35
Diameter of the disc	1.5 cm (0.594 inches)

Thickness of the disc	0.48 cm (0.188 inches)
Diameter of the Pyrex column	1 1/8 inches
Mean perimeter for liquid flow	0.127 ft.
Equivalent diameter for gas flow	0.059 ft.
Absorption surface (dry)	0.22 sq. ft.

Constants of Wetted-wall Column

Liquid inlet opening gap = 1/16"
 Liquid outlet opening gap = 7/64"
 Absorption area (dry) = 0.054 sq. ft.

Sample Calculation of Liquid-film Coefficient:

(A) Absorption of oxygen by water in the wetted-wall column.

Data: (Run No. WW - 5)

Liquid rate = 13.2 lb./hr.

Liquid inlet temperature = 25.0°C

Liquid outlet temperature = 24.2°C

H_{in} , Henry's law constant corresponding to liquid inlet temperature
 (interpolated from Perry's "Chem. Eng. Handbook") = 4380

H_{out} = 4320 atmosphere/mole fraction of oxygen in solution

Atmospheric pressure = 747.1 mm Hg.

Manometer reading (both inlet and outlet) = 11 mm H₂O = 0.8 MM Hg.

Gas inlet temperature (outlet of water saturator) = 22.7°C

Saturated vapor pressure corresponding to inlet gas temp. = 20.7 mm Hg

$f_{\text{solution}} \approx f_{H_2O} = 62.254 \text{ lb./cu.ft.}$

$C'_{in} = 5.30 \times 10^{-4}$, lb. O₂/cu.ft. = 8.52×10^{-6} lb.O₂/lb.H₂O

$C'_{out} = 9.54 \times 10^{-4}$, lb. O₂/cu.ft. = 15.33×10^{-6} lb. O₂/lb. H₂O

Calculation:

$$P_{O_2} = (747.1 + 0.8 - 20.7)/760 = 0.9568 \text{ atm.}$$

$$(C'_e)_{in} = 32 \int_{H_2O} P_{O_2} / 18 H = 32 \times 62.254 \times 0.9568 / 18 \times 4380 \\ = 0.02417 \text{ lb. } O_2/\text{cu. ft.}$$

$$(C'_e)_{out} = 32 \times 62.254 \times 0.9568 / 18 \times 4320 = 0.02452 \text{ lb. } O_2/\text{cu. ft.}$$

$$\text{Oxygen absorbed} = (C'_{out} - C'_{in}) \times L' = (15.33 - 8.52) \times 13.2 \times 10^{-6} \\ = 8.99 \times 10^{-5} \text{ lb. } O_2/\text{hr.}$$

$$(\Delta C')_{l.m.} = \frac{[(C'_e)_{out} - C'_{in}] - [(C'_e)_{in} - C'_{out}]}{\ln \frac{(C'_e)_{out} - C'_{in}}{(C'_e)_{in} - C'_{out}}} = 0.0241$$

where $(\Delta C')_{l.m.}$ = log mean driving force, counter current flow.

$(C'_e)_{out}$ = Concentration in equilibrium with the outgoing gas stream.

$(C'_e)_{in}$ = Concentration in equilibrium with the incoming gas stream.

$$k_L = \frac{O_2 \text{ absorbed}}{A(\Delta C')_{l.m.}} = \frac{8.99 \times 10^{-5}}{0.054 \times 0.0241} = 0.69$$

where A = interfacial area of wetted-wall column = 0.054 sq. ft.

Correction of k_L to 20°C according to the empirical equation of Sherwood and Holloway (16).

$$k_L \text{ at } 20^\circ\text{C} = k_L \times e^{0.023 \times 20 / e^{0.023 \times t}} \\ = 0.69 \times 1.5841 / 1.7683 = 0.62$$

(B) Absorption of oxygen by water in the disc column: The calculation is carried out in the same way as in (A), except the interfacial area, $A = 0.22$ sq. ft.

(C) Absorption of oxygen by water in the packed column:

The equation used in the calculation of the film coefficient, $k_L a$, is derived as follows:

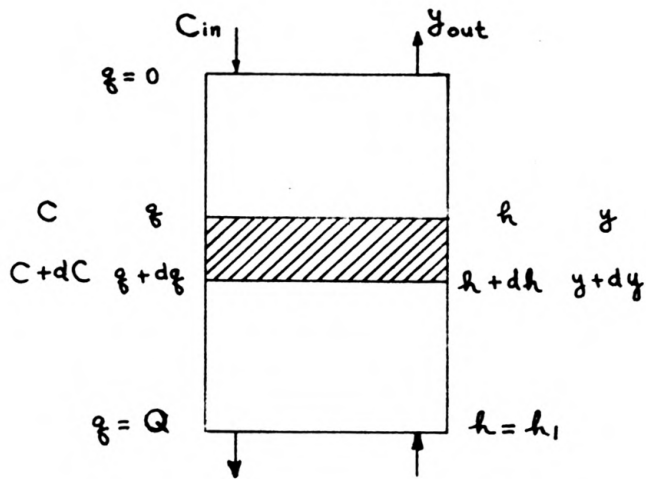

Consider a differential section of height "dh" and cross sectional area "A" in a packed column as shown above where $y =$ gas concentration lb. mole per cu. ft. Assuming equilibrium is maintained at the interface, the mass transfer rate in lb-moles per hour in this section is

$$dq = k_L a (C_e - C) A dh. \quad (m)$$

A material balance over the differential section leads to:

$$dq = \frac{AL}{\rho_L} dC = \frac{AG}{\rho_G} dy \quad (n)$$

where L and G are the liquid and gas flow rates per unit area, respectively.

Combining (m) and (n) and rearranging:

$$dh = \frac{L}{\rho_L k_L a} \frac{dC}{C_e - C}$$

Integrating,
$$h_1 = \frac{L}{\rho_L k_L a} \int_{C_{in}}^{C_{out}} \frac{dC}{C_e - C} \quad (o)$$

Applying the logarithmic-mean driving force concept over the entire column (17)

(o) becomes:

$$h_1 = \frac{L}{\rho_L k_L a} \frac{C_{out} - C_{in}}{(C_e - C)_{l.m.}} = \frac{L}{\rho_L k_L a} \frac{(C_{out} - C_{in})}{(C_e - C)_{out} - (C_e - C)_{in}} \ln \frac{(C_e - C)_{out}}{(C_e - C)_{in}} = \frac{L}{\rho_L k_L a} \frac{\ln \frac{(C_e - C)_{out}}{(C_e - C)_{in}}}{\left(\frac{L}{mG} - 1\right)} \quad (p)$$

where

$$\frac{L}{mG} = \frac{(C_e)_{out} - (C_e)_{in}}{(C_{out} - C_{in})}$$

$$m = \frac{y}{C_e}$$

therefore,

$$k_L a = \frac{L}{R_L h} \ln \frac{(C_e - C)_{in}}{(C_e - C)_{out}} \left/ \left(1 - \frac{L}{mG} \right) \right. \quad (q)$$

The calculation of $k_L a$ is similar to that in (A)

(D) Absorption of oxygen by sulfite solution in the wetted-wall or disc column:

In this calculation it was assumed that all of the absorbed oxygen had reacted with the sulfite solution and therefore no oxygen back pressure is exerted by the liquid. All computational steps were the same as in (A) and (B).

(E) Absorption of oxygen by sulfite solution in the packed column:

In this case, since $C_{in} = C_{out} = 0$ therefore equation (m) may be integrated directly if the variation in C_e is small:

$$k_L a = \frac{Q}{h A (C_e)_{avg.}} \quad (r)$$

Table 5. Effect of oxygen concentration on the rate of absorption of oxygen in sulfite solution.

Run No.	Oxygen concentration : % O ₂	O ₂ absorbed : (lb./hr.) : x 10 ⁵	Liquid concentration : lb. of SO ₃ ²⁻ / cu. ft.	Liquid rate : lb./hr.	Catalyst concentration : x 10 ⁴ m of CuSO ₄	Gas Rate : cu.ft./hr.
A-1	21.1	15.5	0.219	9.82	1	12.3
A-2	37.6	18.3	0.216	9.82	1	11.9
A-3	58.2	32.2	0.216	9.82	1	12.7
A-4	74.9	38.2	0.215	9.82	1	13.2
A-5	100.	49.9	0.215	9.82	1	13.0

Table 6. Effect of gas rate on the rate of absorption of oxygen in sulfite solution.

Run No.	Gas Rate : cu.ft. /hr.	O ₂ absorbed : (lb./hr.)x10 ⁵	Liquid concentration : lb. of SO ₂ ⁺ / : cu.ft.	Liquid rate : lb./hr.	Catalyst concentration : x 10 ⁴ m of : CuSO ₄ .
B-0	5.62	51.9	0.189	9.82	0
B-0 ⁱ	5.62	55.0	0.186	9.82	0
C-0	9.52	51.2	0.188	9.82	0
C-0 ⁱ	9.52	55.1	0.186	9.82	0
C-0 _a	16.31	56.3	0.188	9.82	0
C-0 _a ⁱ	16.31	139.0	0.184	9.82	0
B-5	5.62	34.7	0.165	9.82	1
C-5	9.52	35.0	0.165	9.82	1
C-5 _a	16.31	42.9	0.165	9.82	1
B-4	5.62	39.5	0.177	9.82	5
C-4	9.52	40.4	0.177	9.82	5

Table 7. Effect of liquid rate on the rate of absorption of oxygen in sulfite solution.

Run No.	Liquid Rate: lb./hr.	O ₂ absorbed :(lb./hr.)x 10 ⁵	Liquid concentration lb. of SO ₃ ²⁻ /cu. ft.	Catalyst concentration x 10 ⁴ m of CuSO ₄
D-1	4.24	51.5	0.185	0
D-2	6.85	55.8	0.184	0
B-0	9.82	51.9	0.189	0
B-0'	9.82	55.0	0.186	0
D-3	16.9	46.1	0.115	0
D-4	24.8	141.8	0.115	0
D-5	38.6	433.5	0.168	0
D-6	55.2	616.5	0.168	0
B-1N	4.24	24.7	0.178	10
B-2N	6.85	27.3	0.178	10
B-3N	9.82	29.1	0.180	10
B-4N	16.9	50.0	0.180	10
B-5N	24.8	59.8	0.180	10
B-6N	38.6	81.9	0.170	10
B-7N	55.2	105.3	0.170	10

Table 8. Liquid film coefficients for absorption of carbon dioxide in water.

Run No.	Liquid rate :lb./hr.	CO ₂ absorbed :(lb./hr.)x10 ³	Log mean driving force x 100	k _L 20°C lb./(hr.) (sq.ft.) (lb./cu.ft.)	Gas rate cu.ft./hr.
A1	9.85	8.73	5.69	0.607	10
A2	11.5	9.41	5.71	0.658	"
A3	13.3	10.71	5.12	0.836	"
A4	15.1	12.30	6.30	0.782	"
A5	24.8	18.12	6.42	1.161	"
A6	31.4	25.31	6.22	1.691	"
A7	36.2	28.14	6.45	1.812	"
A8	49.1	37.30	6.40	2.421	"
A9	51.9	39.02	6.29	2.455	"
A10	55.3	43.3	6.50	2.750	"
B1	9.85	9.57	5.93	0.670	18
B2	11.5	10.36	6.23	0.691	"
B3	13.3	10.98	6.21	0.728	"
B4	15.1	11.65	5.90	0.780	"
B5	24.8	18.73	6.20	1.218	"
B6	31.4	25.62	6.50	1.581	"
B7	36.2	29.94	6.50	1.847	"
B8	49.1	39.35	6.67	2.366	"
B9	51.9	41.75	6.91	2.588	"
B10	55.3	44.71	6.90	2.744	"
C1	9.85	8.74	4.90	0.677	6.3
C2	11.5	9.78	5.17	0.726	"
C3	13.3	10.80	5.46	0.766	"
C4	15.1	12.13	5.56	0.861	"
C5	24.8	18.33	5.91	1.224	"
C6	31.4	24.47	5.92	1.667	"
C7	36.2	28.38	5.79	1.956	"
C8	49.1	37.63	5.97	2.542	"
C9	51.9	39.02	6.09	2.609	"
C10	55.3	40.65	6.35	2.634	"

EXPLANATION OF PLATE X

Two-film Theory, Three Possible Cases, Assuming Gas-liquid Equilibrium
Is Attained At the Interface

- (A) Both gas-and liquid-film resistance are appreciable.
- (B) Liquid-film resistance predominate.
- (C) Gas-film resistance predominate.

PLATE X

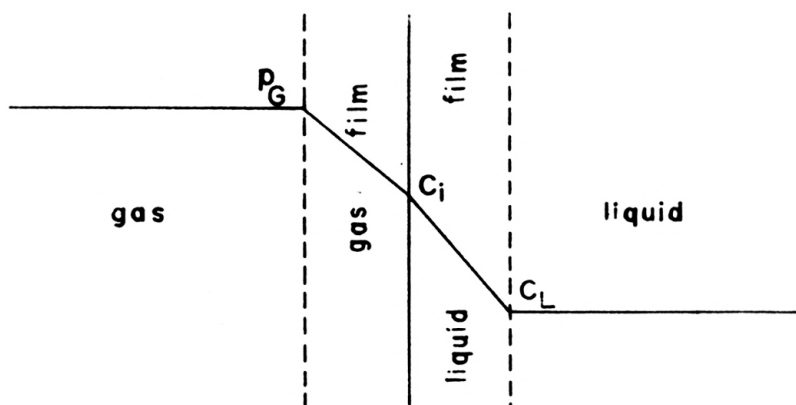

(A)

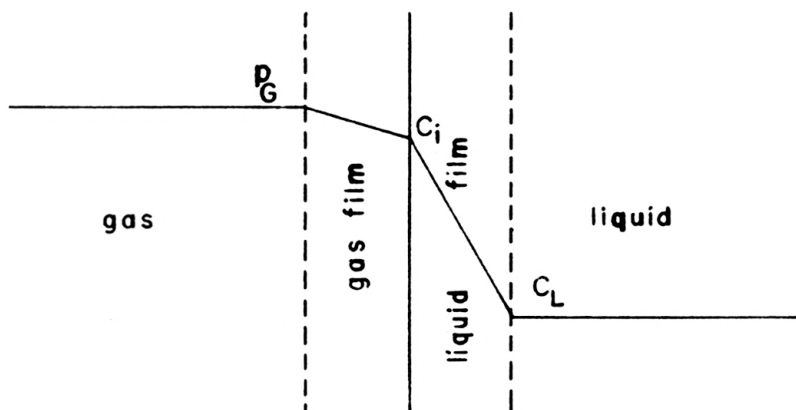

(B)

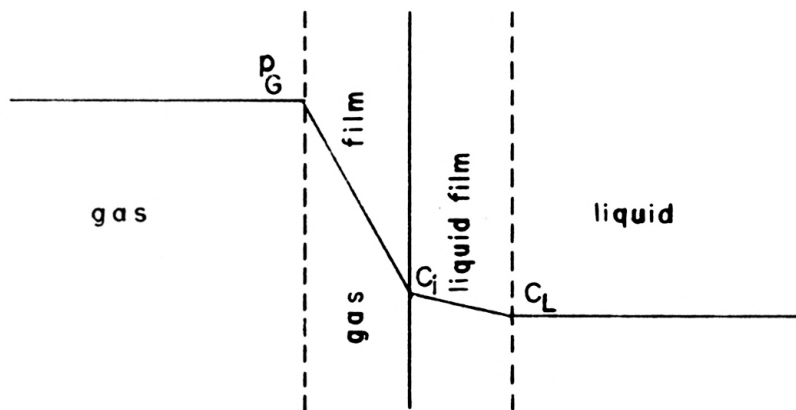

(C)

Nomenclature

- A = Interfacial area, sq. ft.
- a = Effective area in a packed column, sq. ft./cu. ft.
- C = Liquid concentration, lb.-mole/cu. ft.
- C' = Liquid concentration, lb./cu. ft.
- D = Diffusivity, sq. ft./hr.
- G = Gas rate, lb./(sq. ft.)(hr.)
- H. = Henry's law constant, atm./mole fraction of solute in solution.
- h = Height of column, ft.
- k = Mass transfer film coefficient for physical absorption, lb.-mole/(hr.)(sq. ft.)(lb.-mole/cu. ft.) or lb./(hr.)(sq. ft.)(lb./cu. ft.)
- k' = Mass transfer film coefficient for chemical absorption, lb.-mole/(hr.)(sq. ft.)(lb.-mole/cu. ft.) or lb./(hr.)(sq. ft.)(lb./cu. ft.)
- L = Liquid rate, lb./(sq. ft.)(hr.)
- L' = Liquid rate, lb./hr.
- m = Slope of equilibrium curve
- N = Mass transfer rate, lb.-mole/(hr.)(sq. ft.)
- N' = Average mass transfer rate up to time θ , lb.-mole/(hr.)(sq. ft.)
- P = Barometer reading (mm Hg)
- p = Partial pressure, atmosphere.
- Q = Quantity of mass transferred, lb.-mole.
- q = Quantity of mass transferred, lb. mole.
- q' = Quantity of mass transferred, lb.
- S = The mean rate of production of fresh surface in Danckwerts penetration theory, fraction of total surface area renewed per unit time.
- s = Parameter of Laplace transform
- X = Thickness of the hypothesized film, ft.

x = Distance in the liquid phase, measured from the interface, ft.

y = Gas concentration, lb./cu. ft.

Greek Letters

Δ = Difference

δ = Deviation

θ = Time, hr.

π = 3.141592.....

ρ = Density, lb./cu. ft.

Subscripts

avg. = average

e = equilibrium

G = Gas phase

i = Interface

in = Inlet

L = Liquid phase

o = Initial condition, at θ

out = Outlet

A STUDY OF GAS ABSORPTION WITH CHEMICAL REACTION
IN VARIOUS TYPES OF COLUMNS

by

MIN-SHUEY LIN

B. S., National Taiwan University, China, 1951

AN ABSTRACT OF A THESIS

submitted in partial fulfillment of the

requirements for the degree

MASTER OF SCIENCE

Department of Chemical Engineering

KANSAS STATE COLLEGE
OF AGRICULTURE AND APPLIED SCIENCE

1956

The application of gas absorption in chemical engineering practice has reached such a point that further significant advances would probably come in two ways: (1) the formulation of a more rigorous expression to describe the kinetics of the processes and (2) the formulation of some scheme by which design specifications can be made on the basis of a minimum amount of laboratory data, especially for the case where the physical absorption is accompanied by chemical reactions. The overall objective of the present investigation has been oriented towards the latter.

Two schools of thought prevail concerning the hydrodynamic factors in gas absorption: (1) the fluid flow mechanism does not affect the reaction rate, consequently the ratio between the "physical absorption" and "chemical absorption" rates should be independent of the flow mechanism and (2) the flow mechanism does affect the reaction rate, therefore the relationships between the two kinds of absorption do change with the different types of column used. The first assumption has been supported by theoretical argument, but available data do not bear it out. The second assumption introduces difficulties in theoretical formulation because of the lack of knowledge about the hydrodynamics itself in the industrial equipment, such as a packed column.

A direct experimental approach has been adopted in the present work. A short, wetted-wall column and a glass Raschig ring column were constructed. Together with the disc column, these three constituted a series of absorption apparatus of varying degree of complexity in flow pattern. The absorption of oxygen into water was chosen as the typical physical absorption system with the main resistance to mass transfer on the liquid side. There remained then the choice of a corresponding system which involves chemical reactions.

The absorption of oxygen into a sulfite solution was studied to determine whether it would make a convenient test system. The experimental procedure was developed so that a pair of physical and chemical absorption rates were obtained in each of the three representative types of columns. The absorption rates and the liquid film coefficient would then provide a basis for qualitative comparison and quantitative correlation of the effect of the flow pattern between different types of columns. The experimental results are summarized as follows:

1. In all three columns, absorption rate data of oxygen in water were in agreement with the theoretical prediction. The liquid film coefficient, k_L , was found to be independent of the gas flow rate, but it increased when the liquid flow rate was increased.

2. For the disc column, there is a constant ratio between k_L and k_L' , the liquid film coefficients of the oxygen-water system and the oxygen-sulfite system, respectively.

3. The data of the wetted-wall column and the packed column, however, are limited and do not show any simple relationship between k_L and k_L' .

4. The effect of catalyst in the oxidation of sulfite was studied in the disc column at various sulfite concentrations. Reagent grade cupric sulfate was introduced in the liquid feed solution as the catalyst. At the higher sulfite concentrations (0.839 - 1.132N), the absorption rate increased slightly; but at lower sulfite concentrations (0.115 - 0.189N), the catalytic effect became negative and reduced the absorption rate by about 50 per cent. At the present, this anomaly can only be attributed to the composite catalytic actions of the impurities present in the reagents.

Further study of the chemical kinetics itself, without the complication of the absorption step, is necessary in order to resolve the uncertainties

in the oxygen-sulfite absorption data. However, it is believed that the experimental scheme developed in the present work offers the most direct and practical approach to the problem of extrapolating physical absorption data to chemical absorption.