

INVESTIGATION AND DESIGN OF A TORQUEMETER
USING SR-4 STRAIN GAGES

by

CARROLL KENT REECE

B. S., Kansas State College of
Agriculture and Applied Science, 1952

A THESIS

submitted in partial fulfillment of the
requirements for the degree

MASTER OF SCIENCE

Department of Agricultural Engineering

KANSAS STATE COLLEGE
OF AGRICULTURE AND APPLIED SCIENCE

1957

TABLE OF CONTENTS

INTRODUCTION	1
PURPOSE OF INVESTIGATION	2
REVIEW OF LITERATURE	3
Use of SR-4 Strain Gages for Measuring Torque	3
Selection of Strain Gages	4
Selection of Slip Ring Materials	5
Applying SR-4 Strain Gages	6
STRAIN GAGE THEORY	6
Bonded Wire Gage Characteristics	6
Basic Instrumentation	8
The Balanced Bridge	8
The Unbalanced Bridge	11
THE INVESTIGATION	13
Materials and Methods	13
The Initial Torquemeter Design	14
Applying the Strain Gages	26
Installing the Slip Rings	34
A Design Modification	42
Calculation of Torque	50
Discussion of Instruments	52
The Brush Amplifier	53
The SR-4 Strain Indicator	57
TESTING THE TORQUEMETER	60
Static Test	60

Comparison between Values Obtained from a Dynamometer and the Torquemeter	63
An Application of the Torquemeter	66
RECOMMENDATIONS FOR FURTHER STUDY	70
CONCLUSIONS	79
ACKNOWLEDGMENTS	81
REFERENCES	82

INTRODUCTION

Measurement of power passing through a rotating shaft has been a subject of considerable interest for many years. It is well known that power is a function of the speed at which the shaft rotates per unit of time and the torque applied to the shaft. The measurement of shaft speed is a relatively simple matter as compared to the measurement of torque.

The measurement of torque in round rotating shafts has been of interest to engineers throughout many years. Many devices have been devised to measure the torque output of power units and prime movers. Of these devices, a notable one is the "Prony brake" which makes use of a brake band that is restrained by a lever resting upon a pair of platform scales a given distance from the axis of rotation. The torque is the simple product of the force on the scales times the length of the lever arm. The main disadvantage of this type of torque measuring device is that the power is entirely consumed and dissipated in the device itself, and therefore is not available to operate any type of machine. The brake-type measuring device is entirely unsatisfactory for measuring, for example, the torque passing from an engine to an irrigation pump, or from a tractor to an ensilage cutter through the power take-off shaft.

Numerous devices have been devised to measure torque in the shafting of an operating machine. One such device is an optical arrangement which measures the angle of twist of a torque sensitive member.

A hydraulic torquemeter has been developed by Dr. Wesley F. Buchele, of the Agricultural Engineering Department of Michigan State University.

There has been a definite need for a compact torque sensitive device which can be inserted into a power train between the power source and the power requirement. The use of electrical resistance wire strain gages properly oriented on a rotating shaft, and a suitable means of transferring an electrical signal from the rotating strain gages to a stationary recording instrument, has made such a device possible.

These wire gages have commonly been called SR-4 strain gages, named after two men who simultaneously and independently developed them. These two men were Simmons, of the California Institute of Technology, and Ruge, of the Massachusetts Institute of Technology.

The advantages of using these gages for torque measurement are:

- (a) small physical dimensions
- (b) light weight
- (c) ease of installation

The disadvantages include the necessity for slip rings and brushes, and the necessity for adequate temperature compensation.

PURPOSE OF INVESTIGATION

There is a need to make tests on irrigation pump installations to determine the efficiency of the pumps and power units

separately. To do this it is necessary to know the power output of the power unit and the power input to the pump.

The purpose of this investigation was to design, build, and test a compact torquemeter to be used specifically for measuring the torque in the power couplings between irrigation pumps and their power supplies. With this torque known, it is possible to calculate the engine efficiency and the pump efficiency separately.

The same torquemeter was also to be easily adapted to the measurement of torque in tractor power take-off shafts.

REVIEW OF LITERATURE

Use of SR-4 Strain Gages for Measuring Torque

The use of SR-4 strain gages for measuring torque in various machine elements has been practiced by several companies. Jensen (5) stated that the John Deere Waterloo Tractor Works had designed a torquemeter utilizing SR-4 gages to be used in measuring torque in tractor power take-off shafts. Schoenleber (10) also stated that the J. I. Case Co. had used SR-4 gages in the measurement of torque in tractor power take-off shafts and in the measurement of tractor steering torque.

Ruge, et al. (8) stated that bending stresses, stresses attributed to an axial load on the shaft, and effects attributed to temperature changes in the shaft could be canceled by placing the complete bridge circuit in a certain pattern on the torque

sensitive member. This permits the measurement of pure torque.

The Baldwin Lima Hamilton Corporation (13) has manufactured several models of commercial torquemeters which make extensive use of SR-4 strain gages.

Selection of Strain Gages

Schoenleber (10) stated that SR-4 strain gages were classified according to filament material and mounting material. SR-4 gages utilize only two different types of filament materials.

Type A gages are made of advance wire containing 45 per cent nickel and 55 per cent copper.

Type C gages are made of "iso-elastic" wire containing 36 per cent nickel, 8 per cent chromium, and 0.5 per cent molybdenum. The remaining percentage is made up of iron and other constituents. The two general types of mounting materials are paper impregnated with nitrocellulose cement and paper impregnated with bakelite cement.

Iso-elastic wire is from 50 to 100 times more sensitive to temperature than advance wire. The gage factor for iso-elastic wire is almost twice that of advance wire. Gage factors for iso-elastic wire gages range from 2.7 to 3.5, while advance wire gage factors range from 1.5 to 2.0. Iso-elastic strain gages were recommended by the Baldwin Lima Hamilton Corporation (12) for the measurement of dynamic strains because of their larger gage factor. The gage factor is defined as the ratio of the unit change in resistance of the gage to the unit change in

length of the gage. It was pointed out that their larger temperature sensitivity was a factor to be considered.

Jensen (5) stated that 500-ohm bakelite gages were used in the John Deere torquemeter.

Selection of Slip Ring Materials

Signals from the strain gages mounted on the rotating shaft must be transmitted to stationary recording equipment. This must be done with the aid of some type of collector ring mounted on the shaft. Schoenleber (10) named two different types used by the J. I. Case Company. Silver-graphite brushes working on coin silver slip rings were used as one type, and copper discs rotating in mercury pools were used in other applications.

Perry and Lissner (7) have given data on many different brush and slip ring materials. They stated that the most widely used material combination consists of silver or silver-plated rings and silver-graphite brushes.

Lee (6) stated that the brush contact area and contact pressure must be kept large so that the variation in contact resistance is kept small.

Perry and Lissner (7) indicated that the most practical method of minimizing variation in contact resistance is to place the entire bridge circuit on the rotating shaft.

Applying SR-4 Strain Gages

Important information on the best methods of applying SR-4 gages to the test specimen was obtained from Baldwin bulletin 279-B (3). Paper gages should have a clamping force not to exceed one pound. According to the Baldwin Lima Hamilton Corporation (3), bakelite gages must be applied with a clamping pressure of not less than 25 pounds per square inch. A clamping pressure of 100 to 200 pounds per square inch is desirable. Perry and Lissner (7) stated that the clamping pressure for bakelite gages must be at least 30 pounds per square inch.

STRAIN GAGE THEORY

Bonded Wire Gage Characteristics

The wire resistance strain gage consists essentially of a short length of .001-inch diameter wire which is insulated and cemented to the piece being subjected to strain. If the bond between the wire and the piece being tested is sufficiently strong to prevent slippage, the wire will be strained by an amount which is equal to the strain in the specimen under test. The wire used is arranged in a grid and is cemented between two thin pieces of paper for insulation. The wire has the property of linear variation of electrical resistance and strain. Most bonded wire gages are about the size of a postage stamp.

In using bonded wire gages, the two physical quantities

which are of interest are the change in gage resistance and the change in gage length. The dimensionless relationship between these two quantities is termed the "gage factor" and may be expressed as

$$F = \frac{\Delta R/R}{\Delta L/L}$$

where F is the gage factor

R is the resistance of the gage in ohms

ΔR is the small change in gage resistance in ohms

L is the length of the wire in inches

ΔL is the change in length of wire in inches

The gage factor is a measure of the sensitivity of the gage and is supplied by the manufacturer. The resistance of the gage is also supplied by the manufacturer and if the change in resistance (ΔR) can be measured with sufficient accuracy, the only unknown in the equation is $\Delta L/L$. $\Delta L/L$ is defined as the unit strain (ϵ) in inches per inch. The equation then becomes

$$F = \frac{\Delta R/R}{\epsilon}$$

or

$$\epsilon = \frac{\Delta R/R}{F}$$

which is to say that the unit strain in a test specimen is equal to the unit change in resistance ($\Delta R/R$) of the strain gage divided by the gage factor. As the change in resistance is measured, it may be substituted into the equation and the unit strain solved for directly.

Basic Instrumentation

Since the value of ΔR is only a few thousandths of an ohm, it is not possible to measure this quantity with a standard ohmmeter. It is therefore necessary to use a Wheatstone bridge-type circuit to measure ΔR with sufficient accuracy.

The Wheatstone bridge circuit is composed of four resistors connected in a definite pattern, as illustrated in Fig. 1.

The Balanced Bridge

There are two methods of measuring the value of ΔR with the Wheatstone bridge. One method is the balanced bridge method and the other is the unbalanced bridge method.

In Fig. 1, R_1 is considered to be the strain gage, and R_2 , R_3 , and R_4 calibrated resistances. R_g is the galvanometer resistance and I_g is the galvanometer current. The battery, E , is the voltage source for the bridge circuit. I_1 , I_2 , I_3 , and I_4 are the currents through the respective resistances.

If the bridge circuit in Fig. 1 is balanced, there is no current flow through the galvanometer ($I_g = 0$). From Ohm's law ($E = IR$), when the galvanometer current is zero, the voltage drop across the galvanometer is zero. Since the voltage drop across the galvanometer is zero, the voltage at B must be equal to the voltage at C. It then follows that the voltage drop from A to B must equal the voltage drop from A to C. Similarly, the voltage drop from B to D must equal the voltage drop from C to D. It is

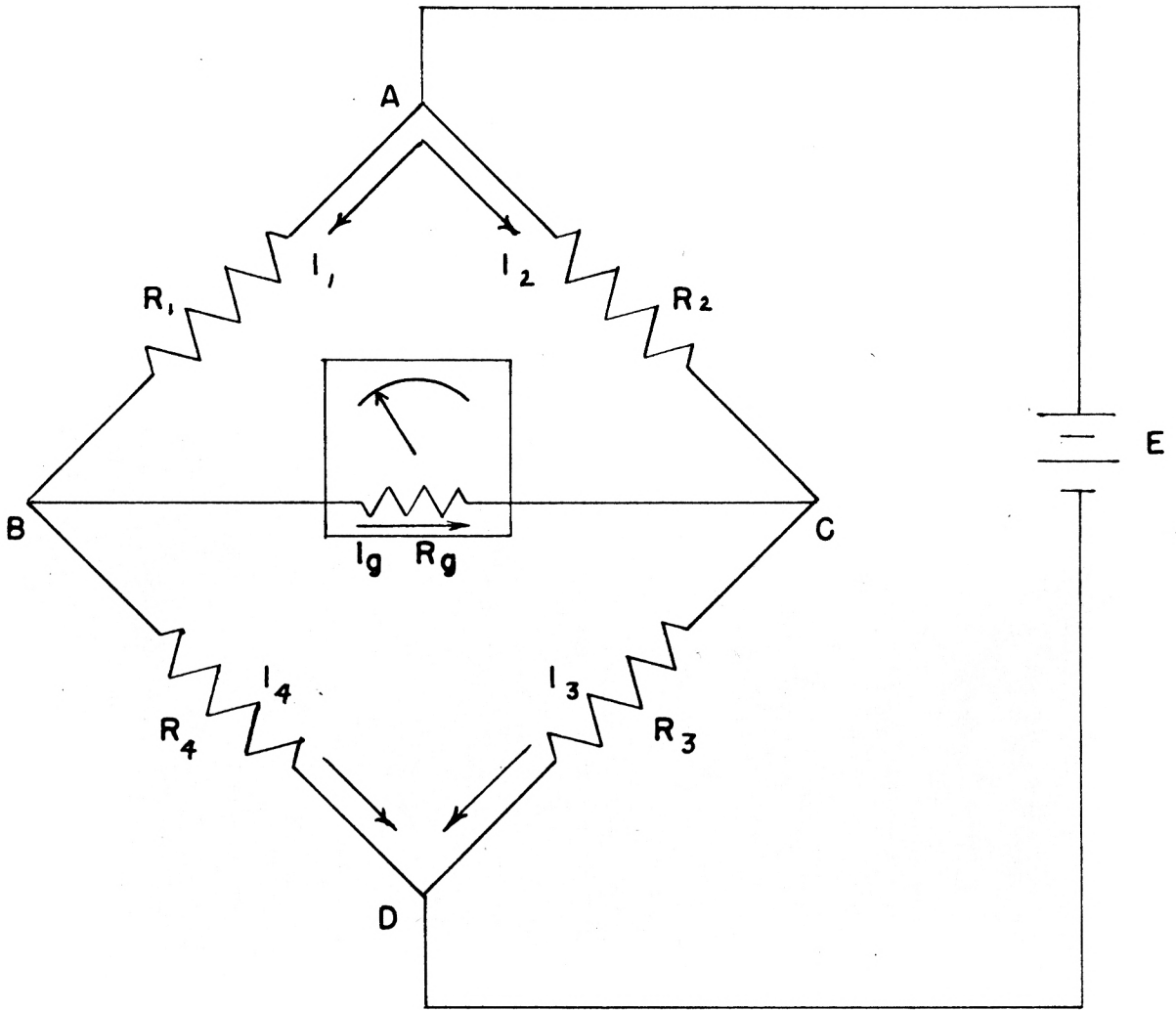

Fig. 1. Basic wheatstone bridge circuit.

also apparent that if no current flows through the galvanometer, the current I_1 must equal I_4 and the current I_2 must equal I_3 . From these observations the following relationships can be written:

$$E_A - B = E_A - C$$

or
$$I_1 R_1 = I_2 R_2$$

and
$$E_B - D = E_C - D$$

or
$$I_4 R_4 = I_3 R_3$$

and since
$$I_1 = I_4 \text{ and } I_2 = I_3$$

then
$$I_1 R_4 = I_2 R_3$$

I_1 and I_2 may now be eliminated by dividing one equation by the other. This gives

$$\frac{I_1 R_1}{I_1 R_4} = \frac{I_2 R_2}{I_2 R_3}$$

or
$$\frac{R_1}{R_4} = \frac{R_2}{R_3}$$

It is now possible to solve for R_1 , which gives

$$R_1 = \frac{R_2}{R_3} R_4$$

R_1 is a strain gage mounted on a test specimen, R_2 and R_3 are known value resistances, and R_4 is a variable resistance of known resistive value no matter what the point of adjustment. The value of R_1 can be determined before and after straining the test specimen by adjusting R_4 . The difference in R_4 caused by the straining process can be substituted into the equation

$$\epsilon = \frac{\Delta R/R}{F}$$

to obtain the unit strain in the test specimen.

Instruments have been developed which have the variable resistance R_4 calibrated in micro-inches per inch of strain. The unit strain can be read directly by balancing the bridge before straining the specimen and noting the reading of R_4 , and balancing the bridge after straining the specimen and noting the reading of R_4 . The difference in the two readings is the unit strain

The instrument used for the balanced bridge method in this study was the SR-4 strain indicator, type M, manufactured by the Baldwin Lima Hamilton Corporation, of Philadelphia, Pennsylvania.

The Unbalanced Bridge

In studying the unbalanced bridge, it is first necessary to state two rules about the currents and voltages in electrical networks.

- (1) The sum of the currents entering a junction of several branches is equal to the sum of the currents leaving the junction.
- (2) The sum of the voltages around any one closed circuit in the network is equal to zero.

For the unbalanced bridge the current through each resistance in Fig. 1 can be expressed from the first rule as:

R_1 current -- I_1

R_2 current -- I_2

R_g current -- I_g

R_4 current -- I_4 -- $I_1 - I_g$

R_3 current -- I_3 -- $I_2 + I_g$

The voltage equations for three different paths can be written using the second rule as stated above.

If the battery is considered as a voltage source E , the voltage equation through path R_1 and R_4 is

$$R_1 I_1 + R_4 (I_1 - I_g) - E = 0$$

For the path through R_1 , R_2 , and R_g , the equation is

$$R_1 I_1 + R_g I_g - R_2 I_2 = 0$$

For the path through R_g , R_3 , and R_4 , the equation is

$$R_g I_g + R_3 (I_2 + I_g) - R_4 (I_1 - I_g) = 0$$

It is necessary to solve these three equations for I_g .

By rearranging, the equations may be written as:

$$R_1 I_1 + R_4 I_1 - R_4 I_g = E$$

$$I_1 (R_1 + R_4) - R_4 I_g = E \quad (1)$$

$$I_1 R_1 + R_g I_g = I_2 R_2 \quad (2)$$

$$-I_1 R_4 + (R_g + R_3 + R_4) I_g = -I_2 R_3 \quad (3)$$

It is possible to eliminate I_2 between equations (2) and (3) by multiplying equation (3) by R_2 and equation (2) by R_3 and adding the two equations.

$$I_1 R_1 R_3 + R_3 R_g I_g = I_2 R_2 R_3$$

$$\underline{-I_1 R_4 R_2 + (R_2 R_g + R_3 R_2 + R_4 R_2) I_g = -I_2 R_3 R_2}$$

$$I_1 (R_1 R_3 - R_4 R_2) + I_g (R_3 R_g + R_2 R_g + R_3 R_2 + R_4 R_2) = 0 \quad (4)$$

By determinants it is possible to solve for I_g from equations (1) and (4).

$$I_g = \frac{\begin{vmatrix} R_1 R_3 - R_4 R_2 & 0 \\ R_1 + R_4 & E \end{vmatrix}}{\begin{vmatrix} R_1 R_3 - R_4 R_2 & R_3 R_g + R_2 R_g + R_3 R_2 + R_4 R_2 \\ R_1 + R_4 & -R_4 \end{vmatrix}}$$

$$I_g = \frac{E(R_1R_3 - R_4R_2)}{-R_1R_3R_4 + R_4^2R_2 - (R_1 + R_4)(R_3R_g + R_2R_g + R_3R_2 + R_4R_2)}$$

$$I_g = \frac{E(R_1R_3 - R_4R_2)}{-R_2(R_1 + R_4)(R_g + R_3 + R_4) - R_1R_3R_4 + R_4^2R_2 - R_3R_g(R_1 + R_4)}$$

In this discussion the strain gage is considered to be R_1 , the galvanometer resistance R_g , and the galvanometer current I_g . R_2 , R_3 , and R_4 are calibrated resistances in the bridge circuit.

It can be shown that the relationship between R_1 and I_g is not quite linear, but for the small changes encountered in R_1 it can be considered to be so. It is then possible to plot the value of I_g in microamperes against the resistance R_1 in ohms over a small range of R_1 . Then for a measured change in I_g the corresponding value of ΔR can be found and the unit strain computed as before. This, however, is not necessary and has not been shown here because instruments have been designed to give the change in I_g directly in terms of unit strain.

THE INVESTIGATION

Materials and Methods

Material for the Torque Sensitive Member. A high grade alloy steel was machined to specifications and used for the torque sensitive member.

Slip Rings and Brushes. A commercial slip ring kit was used to make the slip rings and brush contacts.

Strain Measuring Instruments. Commercially manufactured

strain measuring instruments which give the unit strain directly were used in this study. Both the balanced and the unbalanced bridge methods were used.

Strain Gages. SR-4 strain gages purchased from the Baldwin Lima Hamilton Corporation were used to measure the strain in the torque sensitive member.

Testing. Both static and dynamic tests were run to determine the accuracy of the torquemeter. The static tests were conducted with a lever arrangement and a Tinius Olsen testing machine. The dynamic tests were conducted by checking the torquemeter against a hydraulic-type dynamometer.

The Initial Torquemeter Design

It was decided that the torque sensitive member was to be a round shaft upon which SR-4 strain gages and suitable slip rings were to be mounted. The torquemeter was to be as small and compact as possible and yet have a torque capacity of at least 15,000 inch-pounds.

The best material available for the shaft was alloy steel SAE 4340.

Specifications from a steel handbook indicate the yield point strength of this steel at 96,000 pounds per square inch in tension. Since the maximum shearing stress theory of failure was considered to be valid in this case, the yield point in shear of this material is 48,000 pounds per square inch.

It was tentatively decided that the diameter of the section

of the shaft upon which the strain gages were to be mounted would be 1.50 inches.

Since the maximum torque to which the torquemeter was to be subjected was set at 15,000 inch-pounds, the shear stress in the 1.50-inch diameter shaft would be:

$$S_s = \frac{Tc}{J}$$

where T is torque in inch-pounds, c is the radius of the shaft in inches, and J is the polar moment of inertia of the shaft in inches to the fourth power.

$$S_s = \frac{(15,000)(2)}{\pi(0.75)^3}$$

$$S_s = 22,600 \text{ psi}$$

Since the yield point in shear for the material used is 48,000 psi, the factor of safety would be:

$$\text{F.S.} = \frac{(0.5) S_{yp}}{S_s(\text{max})}$$

where S_{yp} is the yield point of the steel in tension.

$$\text{F.S.} = \frac{48,000}{22,600}$$

$$\text{F.S.} = 2.14$$

It was decided that 1.50 inches would be a satisfactory diameter for the torque measuring portion of the shaft if the maximum permissible torque was set at 15,000 inch-pounds.

With this information available, the torquemeter was initially designed as set forth by the detailed plans in Plates I, II, III, IV, and V.

EXPLANATION OF PLATE I

Drawing of the initial torquemeter design. Wiring and brushes are not shown.

PLATE I

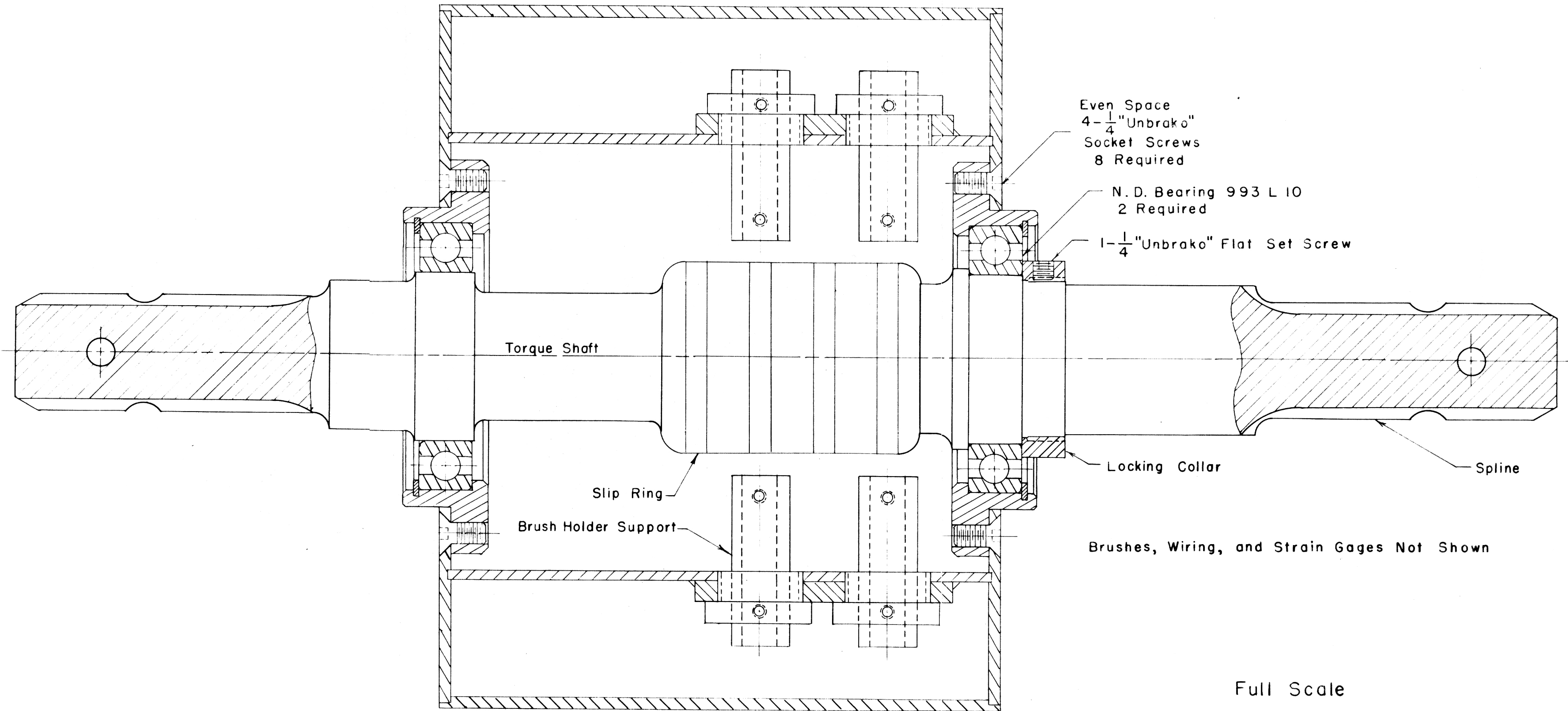

Even Space
4- $\frac{1}{4}$ "Unbrako"
Socket Screws
8 Required

N. D. Bearing 993 L 10
2 Required

1- $\frac{1}{4}$ "Unbrako" Flat Set Screw

Torque Shaft

Slip Ring

Brush Holder Support

Locking Collar

Spline

Brushes, Wiring, and Strain Gages Not Shown

Full Scale

EXPLANATION OF PLATE II

Detailed drawing of the torque shaft. Slip rings
are not shown.

PLATE II

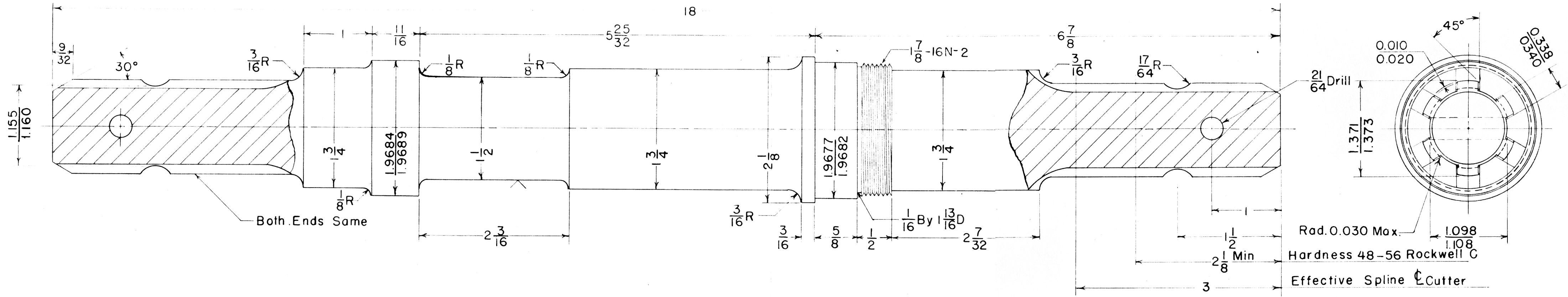

Shaft
Full Scale

Tolerance .010 Unless Noted

EXPLANATION OF PLATE III

Detailed drawings of the bearing hub and the
end plate.

PLATE III

Bearing Hub
Steel - 2 Required

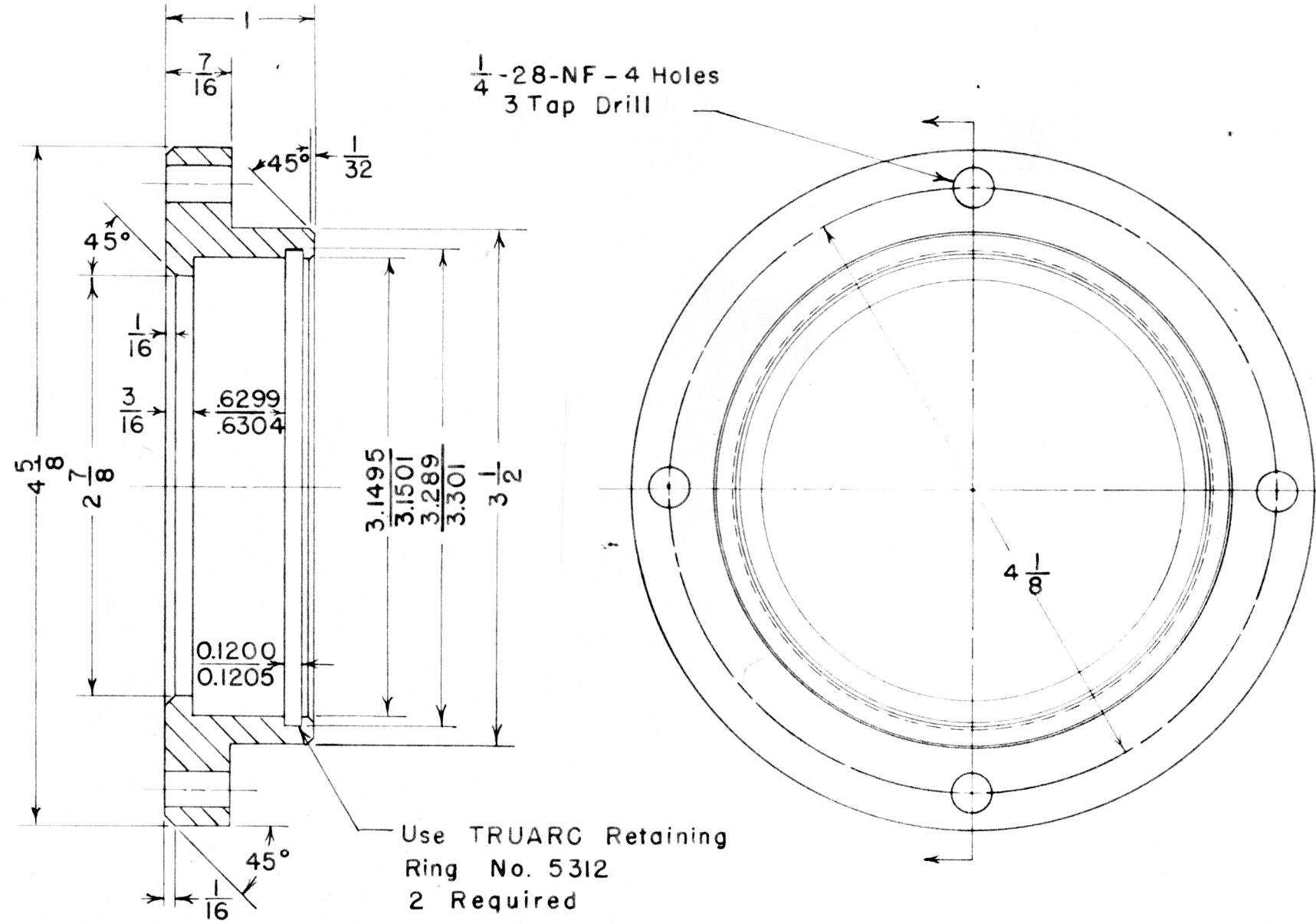

Full Scale
Tolerance .010 Unless Noted

End Plate
Steel - 2 Required

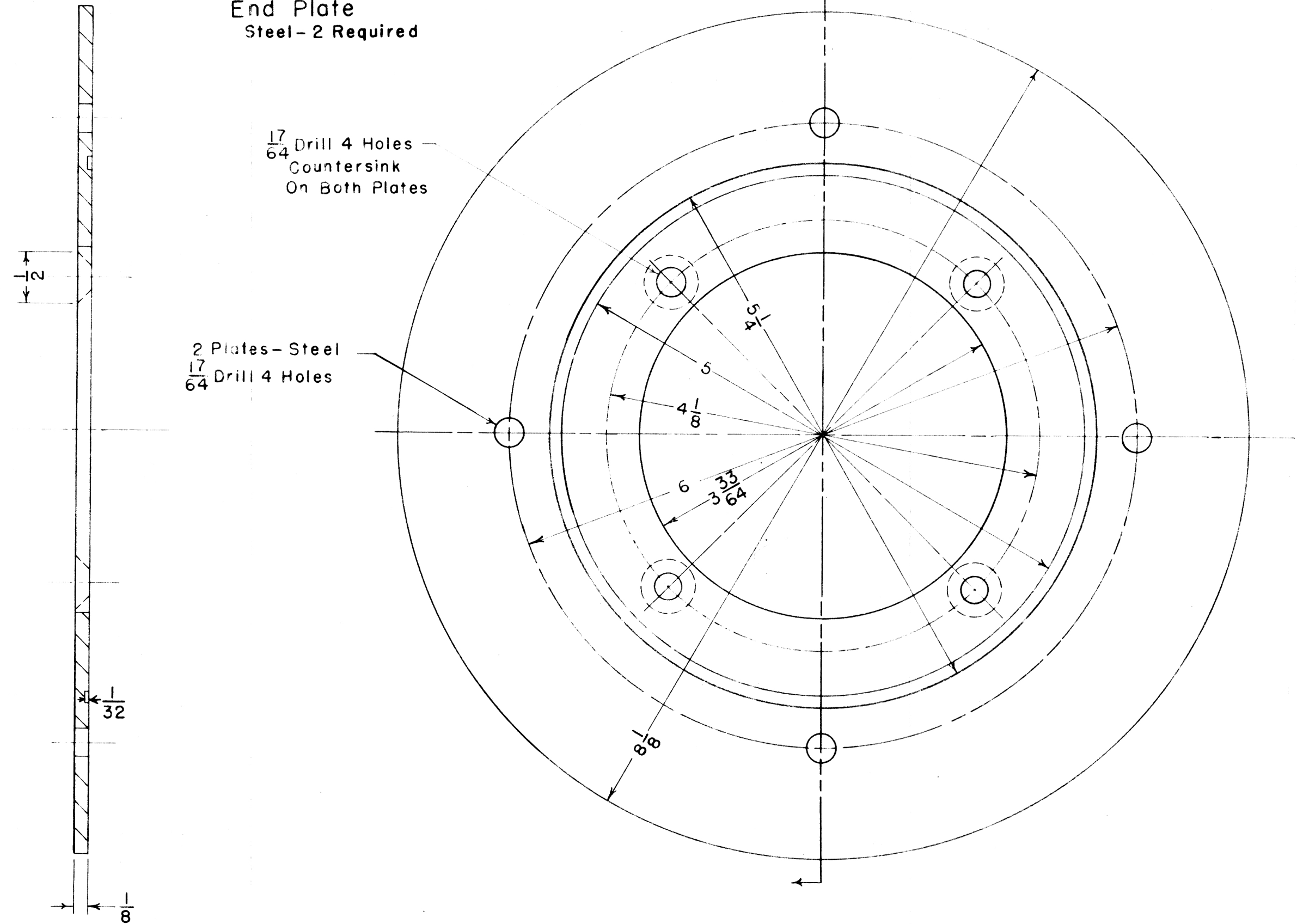

EXPLANATION OF PLATE IV

Detailed drawings of the torquemeter cover and the bearing locking collar.

PLATE IV

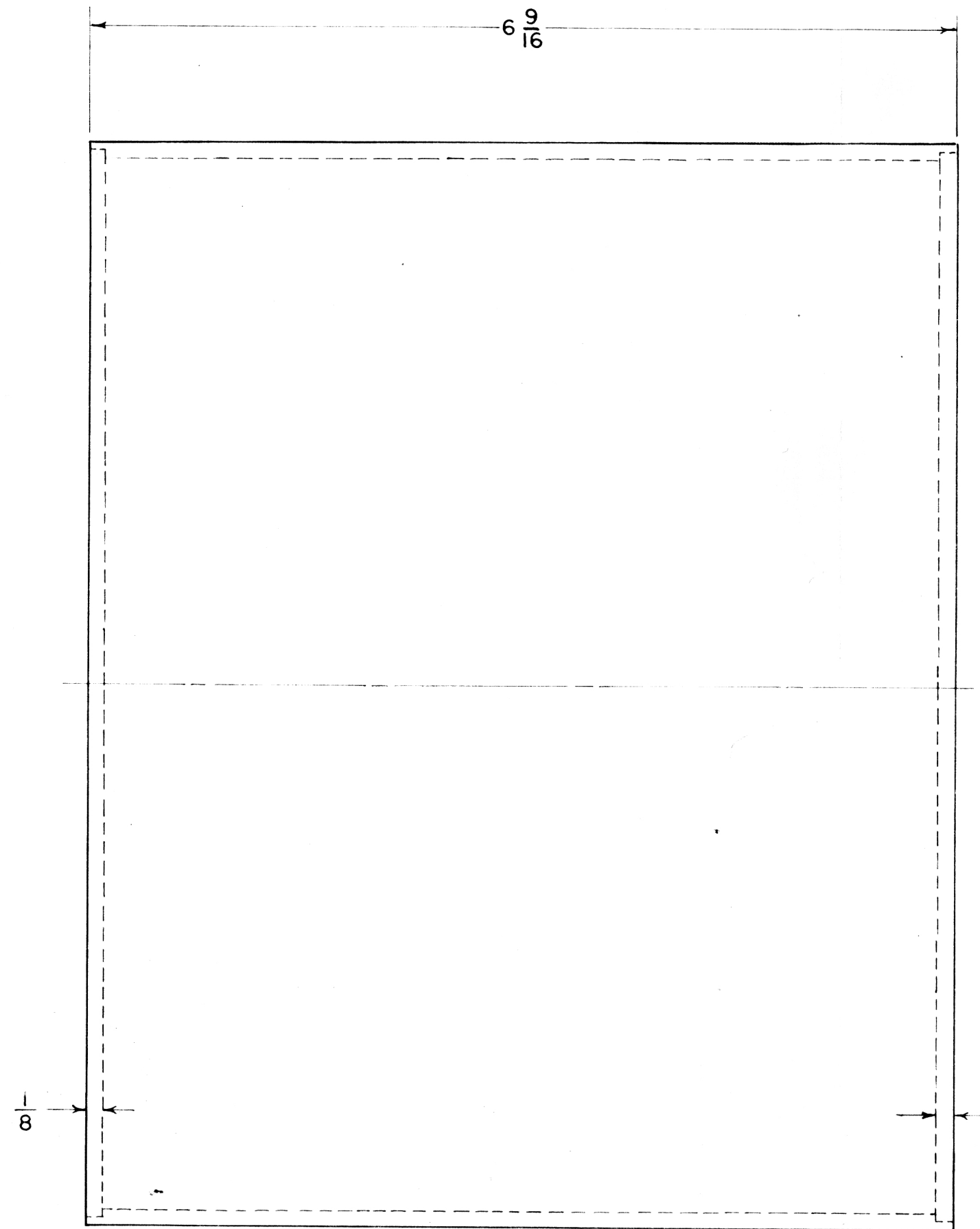

Cover
Steel—1 Req'd

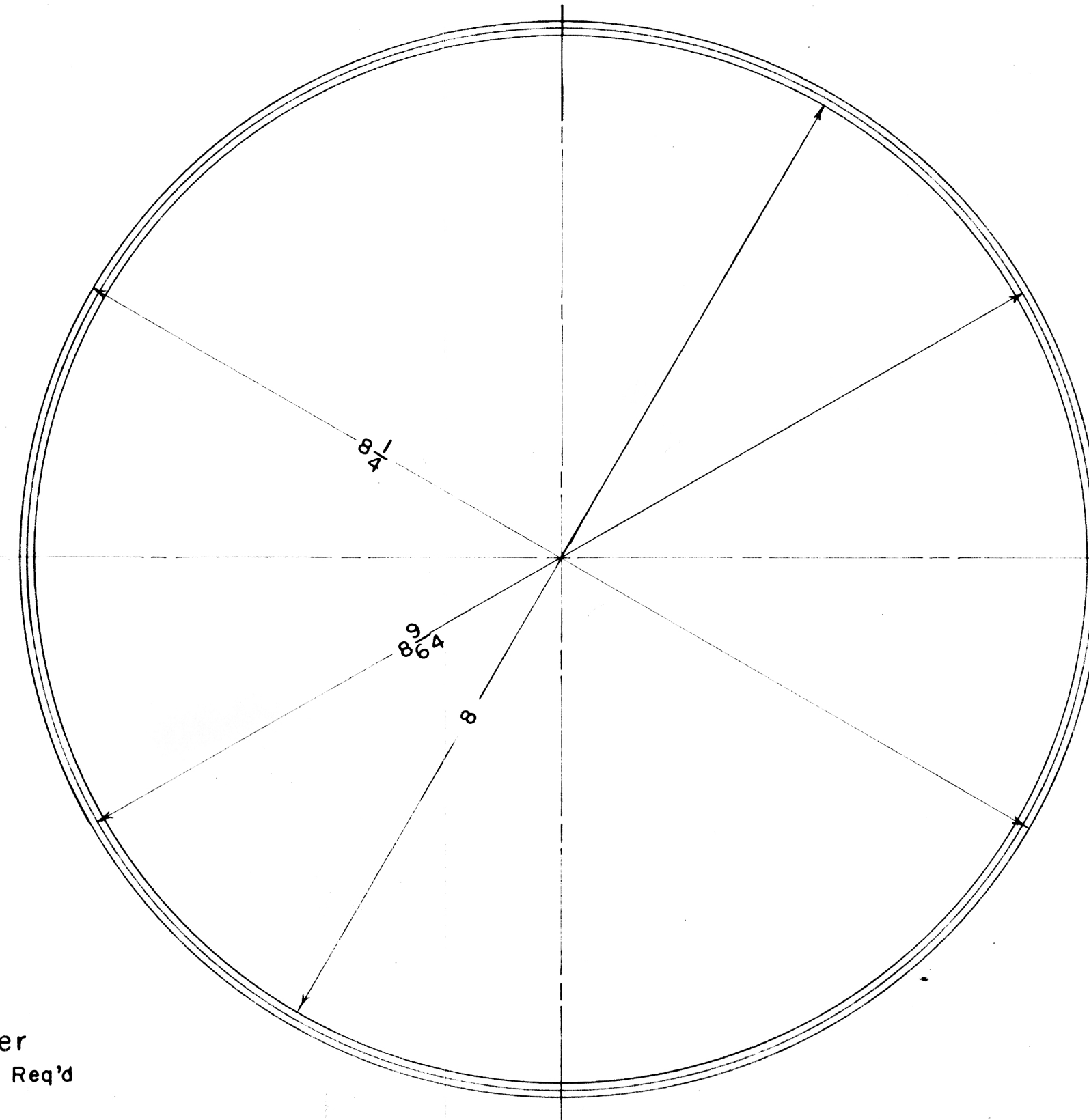

Full Scale

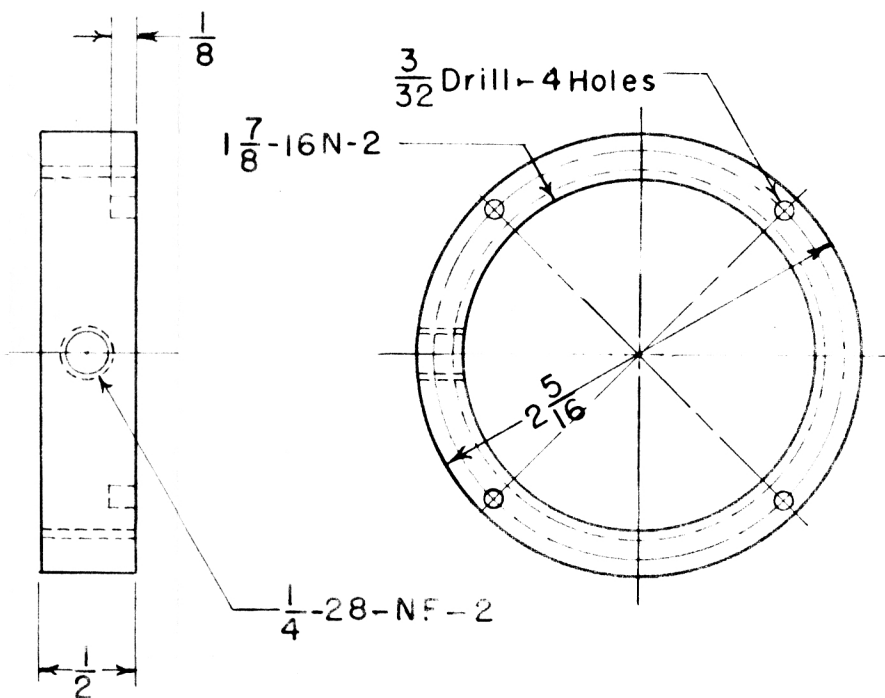

Locking Collar
Steel—1 Req'd

Tolerance .010 Unless Noted

EXPLANATION OF PLATE V

Detailed drawings of the brush holder support assembly.

PLATE V

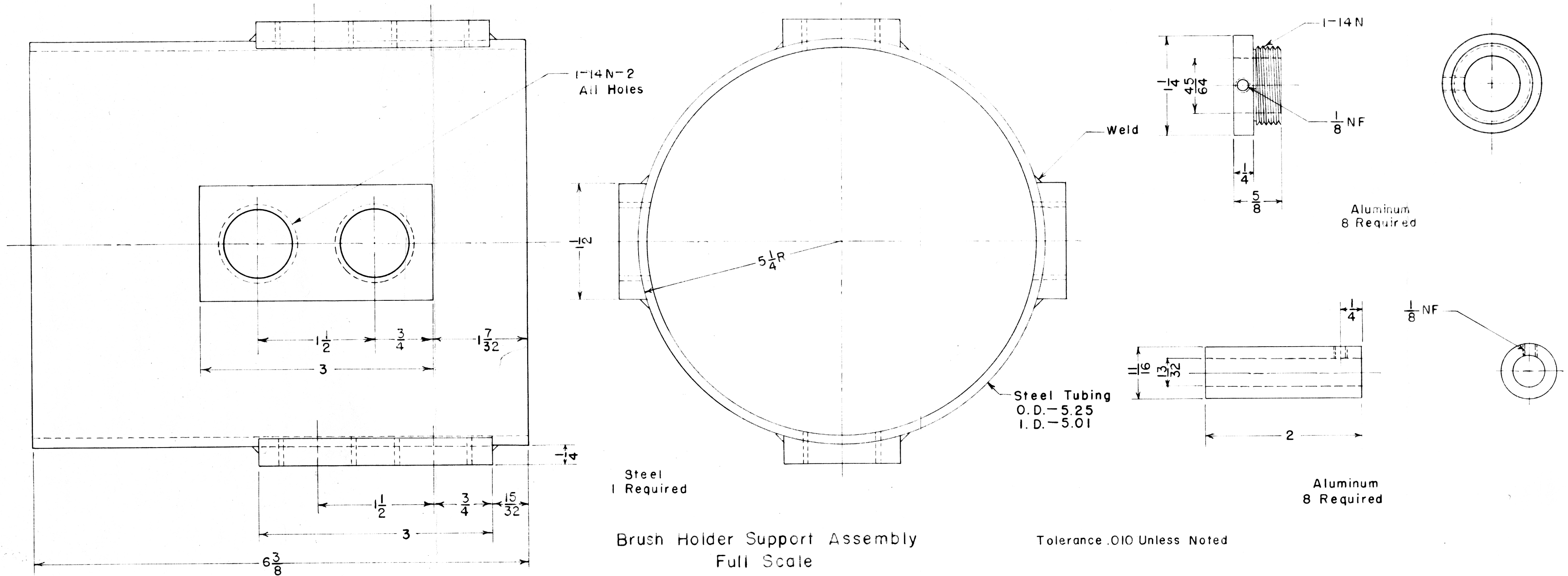

After provisions were made for a support bearing, slip rings, and a splined end on each end of the shaft, the minimum length that the shaft could be with the proposed design was 18 inches.

The shaft was designed with a 1 3/8-inch standard 6B tractor power take-off spline on each end so the torquemeter could be readily adapted to power take-off operation.

The bearings used were of a size that would make it possible to easily remove the shaft and replace it with a shaft which had a 1.75-inch diameter torque measuring section and 1.75-inch standard splines. This would raise the capacity of the torquemeter from 15,000 to approximately 23,800 inch-pounds of torque. The shaft which was actually made and tested was the smaller of the two.

The cover for the torquemeter had a maximum diameter of 8 1/4 inches, and a length of 6 9/16 inches. The torquemeter as initially designed had an overall length of 18 inches and an overall diameter of 8 1/4 inches.

Applying the Strain Gages

The strain gages used in the first test were type CB-7 gages which had a resistance of 495 ± 3 ohms, and a gage factor of 3.43. The CB-7 gages were bakelite bonded gages made of iso-elastic wire. Their length was 1/4 inch.

The gages were placed on the shaft with their center lines on lines which made angles of 45 degrees with the axis of the

shaft. This was done because a shaft subjected to pure torque is under a stress condition of pure shear. From Mohr's Circle for pure shear stress illustrated in Plate VI, Fig. 1, it can be seen that equal stresses in tension and compression act at 45 degrees from the direction of the shear stress. Stresses acting at a point in the shaft are illustrated in Plate VI, Fig. 2.

In order to cancel the effects of stress attributed to bending and axial tension or compression loads on the shaft, it was necessary to place the complete bridge circuit on the shaft as shown in Fig. 2. It was necessary to construct a template of paper as shown in Plate VII, Fig. 1, to accurately place the gages so that R_1 was diametrically opposite R_3 , and R_2 was diametrically opposite R_4 . Holes were cut in the template at the gage positions so that the gages were cemented directly to the shaft. It was necessary to wrap the template around the shaft so that the ends of the center line of the template matched exactly. This insured that the angle that the gages made with the axis of the shaft was 45 degrees.

It is obvious from the arrangement of the gages that a load of axial tension or compression on the shaft would not upset the balance of the bridge since all gages would be stretched or compressed equally.

If a bending moment were applied, gages R_1 and R_4 would be alternately stretched and compressed as the shaft rotated; R_2 and R_3 would be simultaneously subjected to an equal condition, but exactly opposite in sign to the condition of R_1 and R_4 . It is again obvious that the balance of the bridge will not be upset

EXPLANATION OF PLATE VI

Fig. 1. Mohr's Circle for stress.

Fig. 2. Stresses at a point on a shaft subjected to torque.

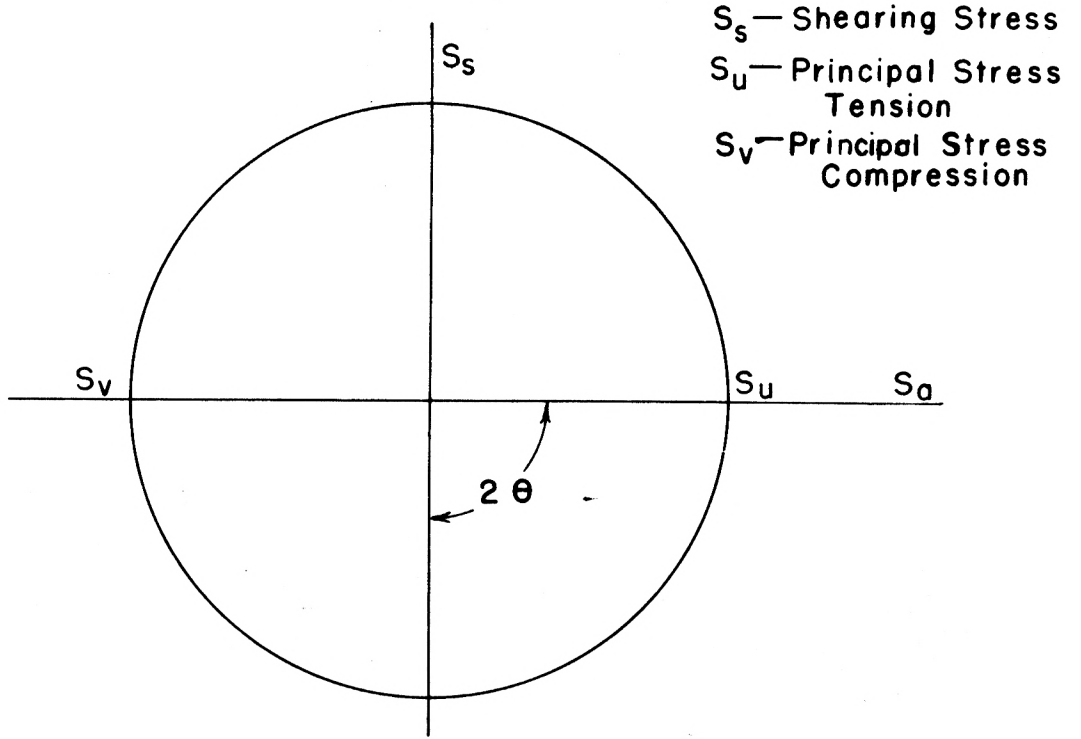

Fig. 1.

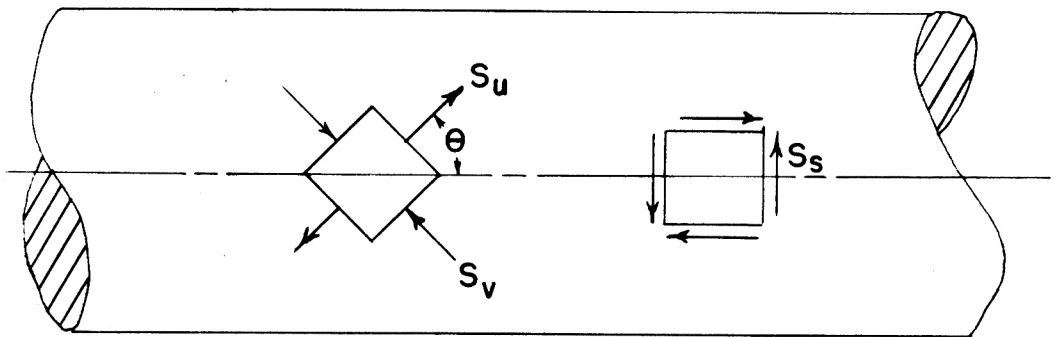

Fig. 2.

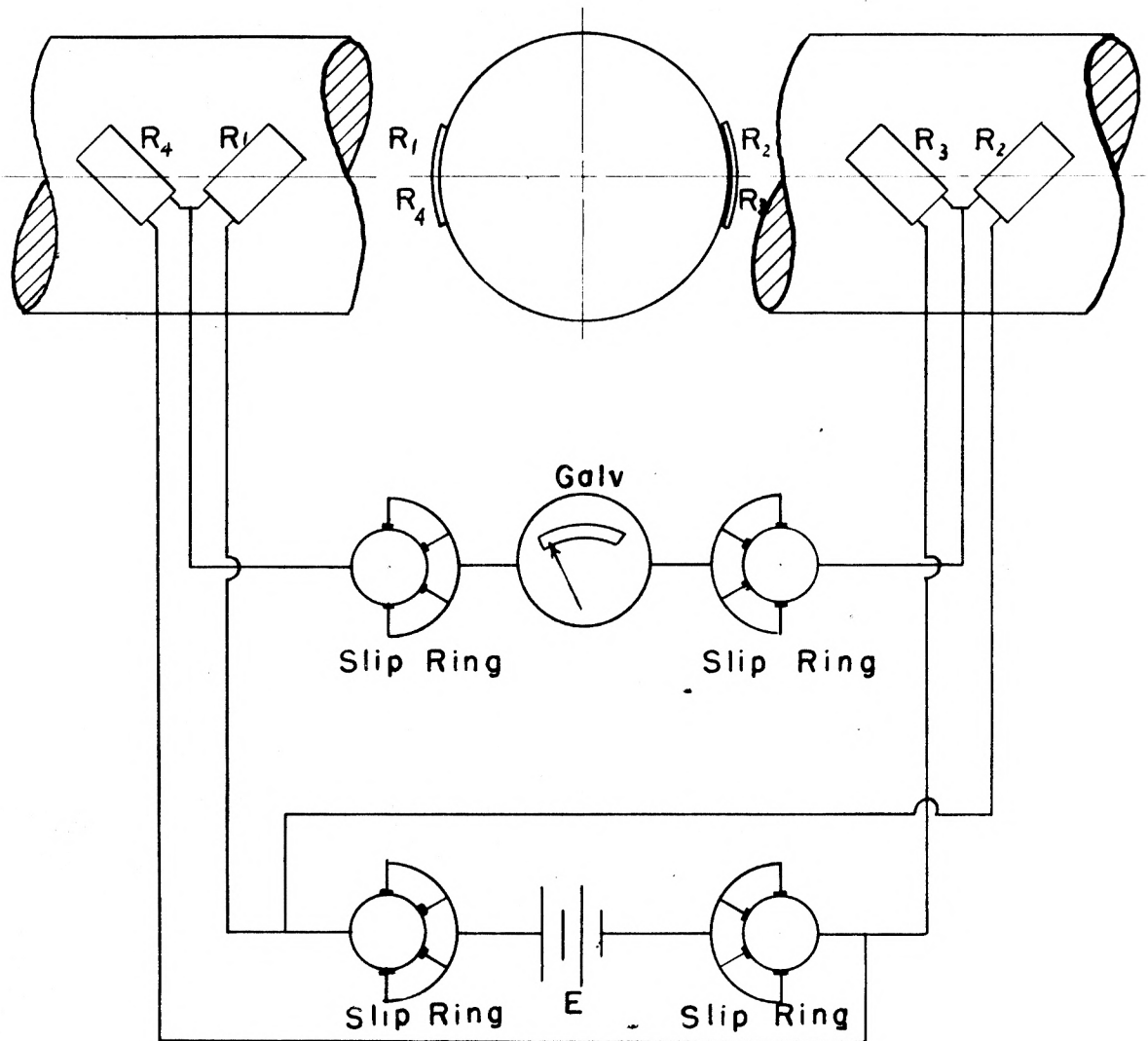

Fig. 2. Schematic wiring diagram of the bridge circuit.

EXPLANATION OF PLATE VII

Fig. 1. First paper template used to mount gages on the shaft.

Fig. 2. Illustration of how the template was applied to the shaft.

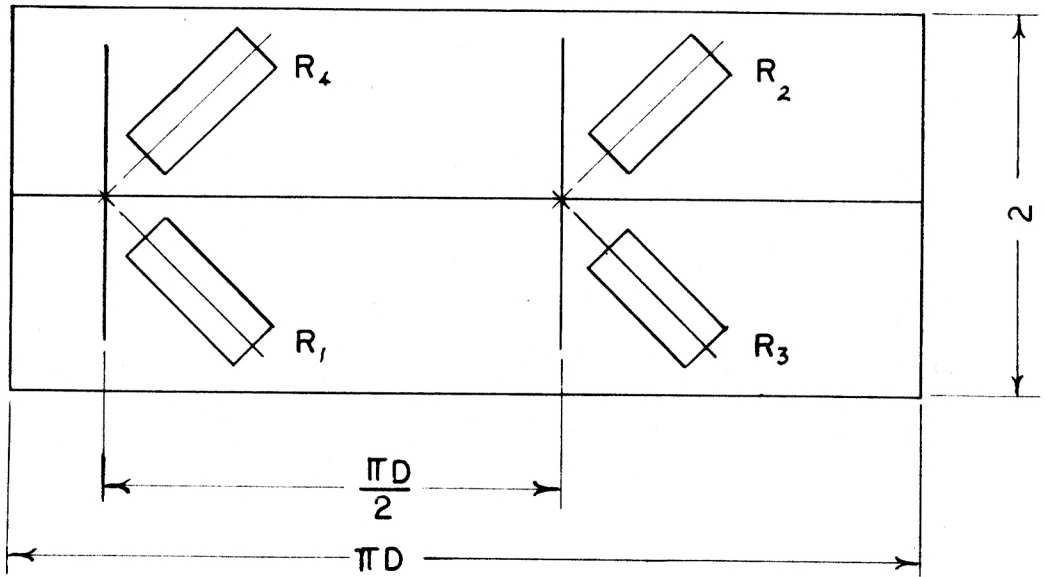

Fig. 1.

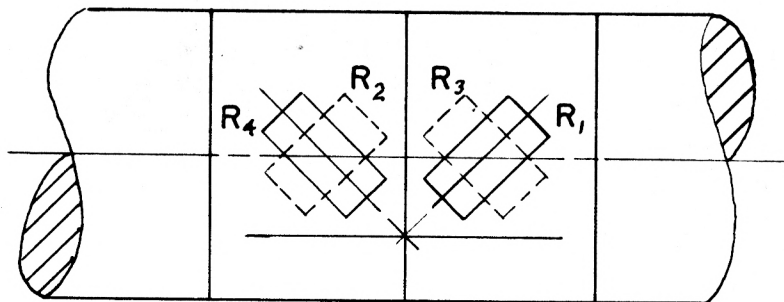

Fig. 2.

by a bending moment because the resistance through path R_1 and R_4 increases the same amount that the resistance through path R_2 and R_3 decreases at any given instant.

This pattern was satisfactory to compensate for bending moments and tensile or compressive loads applied to the shaft. However, it was not satisfactory to compensate for a temperature gradient along the shaft.

In Plate VII, Fig. 2, the solid lines represent the gages on the near side of the shaft and the dashed lines represent the gages on the far side of the shaft. Let R_1 and R_3 be in tension and R_2 and R_4 be in compression. If R_2 and R_4 are at a different temperature than R_1 and R_3 , the bridge will be unbalanced and the amount of unbalance attributed to temperature will be doubled instead of compensated. This is true since R_1 is opposite R_3 , and R_2 is opposite R_4 in the bridge circuit.

The above condition was proved by balancing the bridge and submerging one end of the shaft in a bucket of boiling water, and observing that the bridge did not remain balanced.

It was necessary to correct this source of error since it was not practical to attempt to keep both ends of the shaft at the same temperature. The gages were removed from the shaft and replaced with two CX-1 rosettes.

The CX-1 rosette consists of two iso-elastic gages crossed at the center at an angle of 90 degrees to each other and on the same paper base. The CX-1 gage has a resistance value of 500 ± 3 ohms and a gage factor of 3.43. The rosettes were accurately placed by the use of another paper template as illustrated in

Fig. 3. This arrangement compensated for bending moments, tensile or compressive loads, and temperature gradients as well.

The strain gages were sealed against moisture by placing a piece of aluminum foil over each rosette and then applying a layer of Armstrong's A-1 cement.

Installing the Slip Rings

Since the complete bridge circuit was mounted on the rotating shaft, it was necessary to install four slip rings on the rotating shaft as indicated by the schematic wiring diagram in Fig. 2.

The slip rings were constructed with a commercial kit sold by William T. Bean, of Detroit, Michigan. The kit consists of 1/16-inch silver wire and Armstrong's A-1 adhesive cement which is used for bonding and insulation.

The area on the shaft to which the slip rings were to be applied was first knurled with an ordinary lathe knurling tool. The surface was then thoroughly cleaned with acetone. Four 3-inch lengths of plastic insulating spaghetti were cut and threaded with 1/16-inch diameter wire. These wires were spaced evenly around the shaft and held firmly in place with string, as illustrated in Plate VIII, Fig. 1. A thick layer of Armstrong's A-1 cement was smoothed over the spaghetti covered wires, and the assembly placed in an oven to cure for one hour at 170 degrees F. The shaft was then placed in a lathe and the surface of the adhesive turned down flat, as illustrated in Plate VIII, Fig. 2.

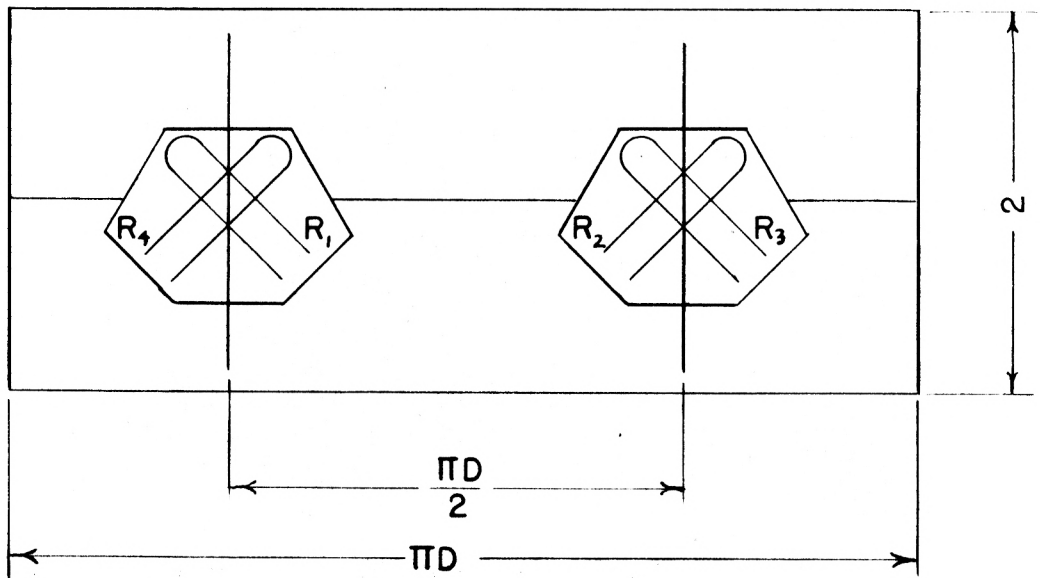

Fig. 3. Paper template for CX-1 rosettes

EXPLANATION OF PLATE VIII

Fig. 1. Drawing of how spaghetti covered wires are fastened to the shaft with string before applying Armstrong's A-1 cement.

Fig. 2. Illustration showing how first layer of cement is turned smooth before winding on silver wire slip rings.

PLATE VIII

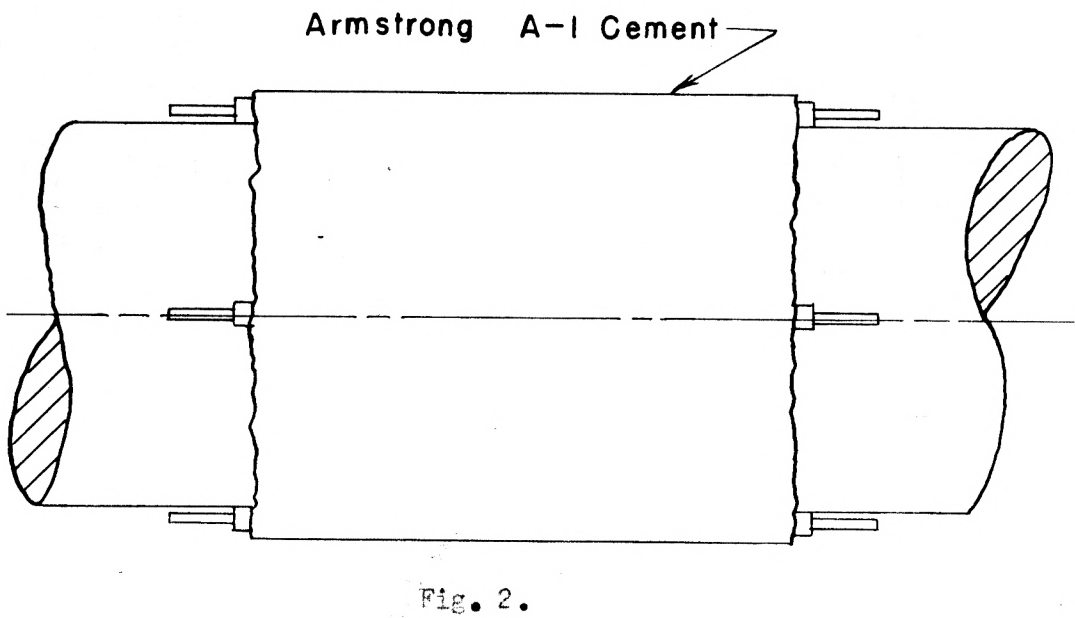
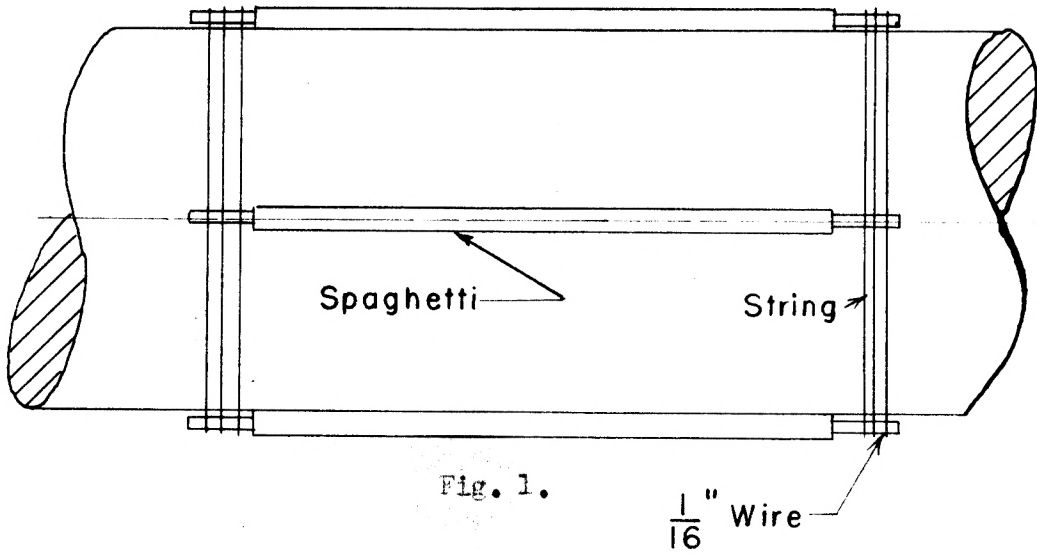

It was necessary to use a carbide-tipped cutting tool since the adhesive is very abrasive. The wire was removed from the spaghetti and slots were filed in the adhesive to intersect the holes in the spaghetti. The slots were filed from the side of the adhesive which was farthest from the strain gages. Each slot was made just long enough to intersect a slip ring position. A sharp 90-degree bend was made in the silver wire far enough from the end so that the silver wire would protrude past the edge of the adhesive. The silver wire was inserted into the spaghetti and at least five turns wrapped around the shaft, as shown in Plate IX, Fig. 1. The silver wire was soft soldered all around the shaft to hold it in place. This process was repeated for each slip ring. After all slip rings were soldered in place they were covered with another thick layer of Armstrong's A-1 cement, and the curing process was repeated. The shaft was again placed in a lathe and the surfaces of the slip rings turned down until they were flat and smooth, as illustrated in Plate IX, Fig. 2. The slip rings were polished with 400 and 600 grit pumice powder and burnished with chrome finish leather.

The strain gage leads were soldered to the protruding ends of the silver wire. It was difficult to solder the leads without melting the solder which held the slip rings in place since silver is an excellent conductor of heat. The soldering operation had to be done very quickly. The completed shaft with slip rings in place is shown in Fig. 4.

The brushes which were furnished with the slip ring kit were silver graphite and had a rubbing surface area of $1/64$ square

EXPLANATION OF PLATE IX

Fig. 1. Cross section showing how wire is wound on the shaft to form the slip ring.

Fig. 2. Cross section showing how the slip rings are turned smooth.

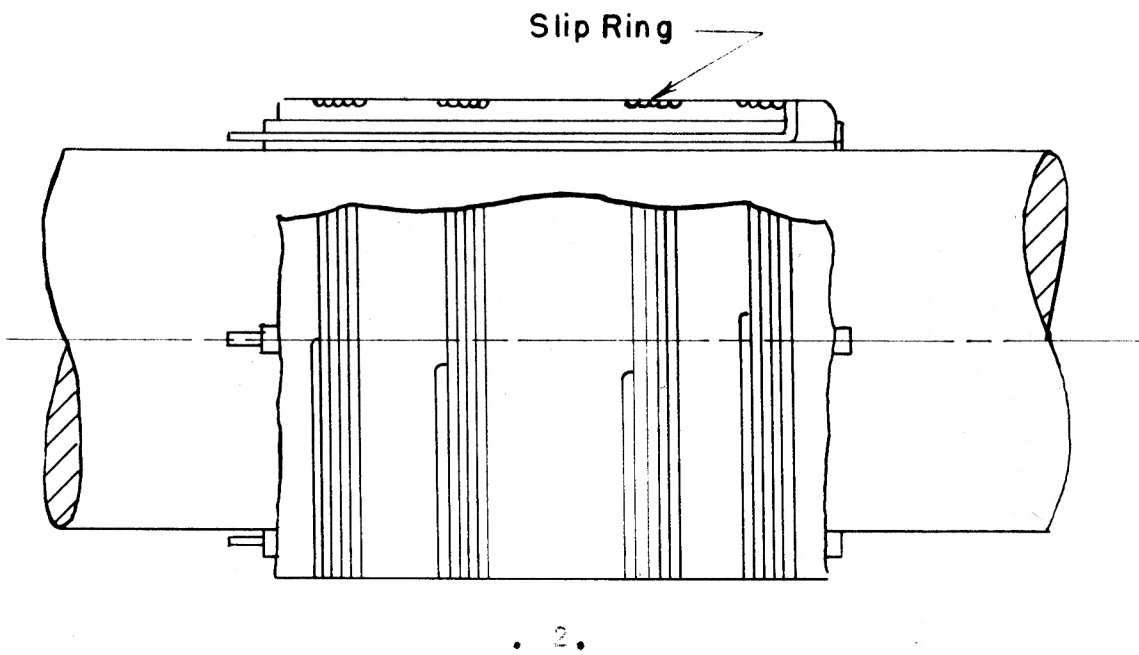
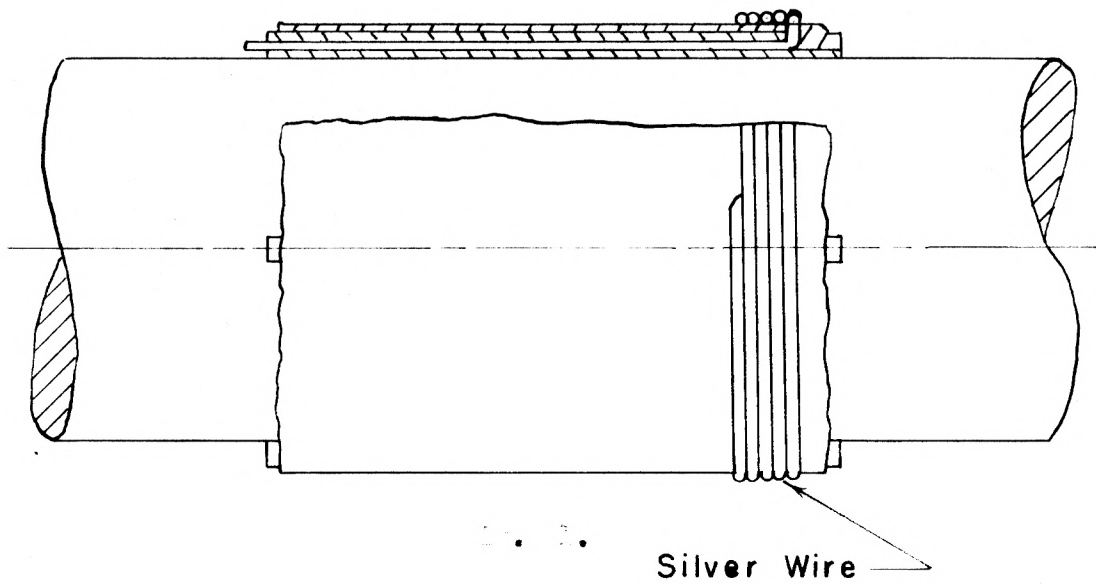

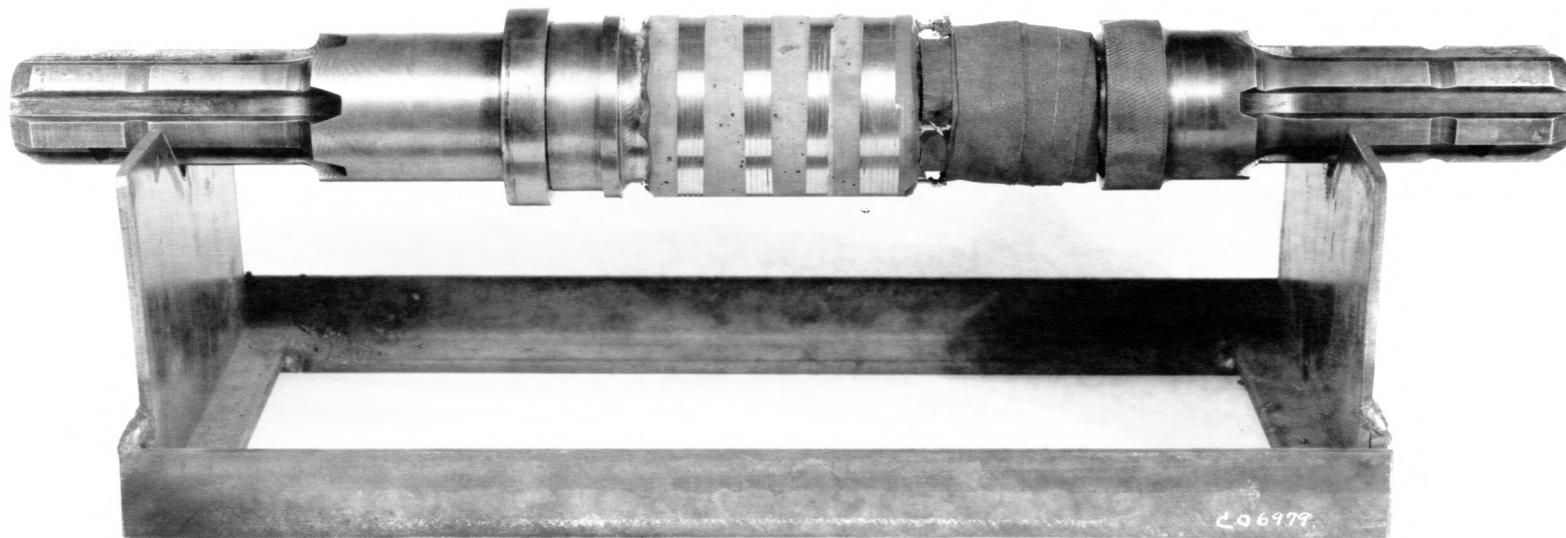

Fig. 4. The completed torquemeter shaft with slip rings in place.

inch. When the end of the brush holder was $1/16$ inch from the slip ring, the force exerted by the brush spring was $3/8$ to $7/16$ of a pound. This gave a brush pressure of 24 to 28 pounds per square inch.

The brush holding device and silver-graphite brush with spring are shown in Fig. 5.

A Design Modification

Before testing was started it was decided that it would be advantageous if the torquemeter could be made smaller. The assembly which supported the brush holders was redesigned. All parts except the bearing hubs, bearings, and shaft were discarded. Another support assembly for the brush holders was designed around the parts which were retained from the initial design. The second support assembly and protective cover are shown in Plates X and XI.

This modification in design made it possible to put four brushes on each slip ring instead of the two which were originally planned. Four brushes instead of two per slip ring were used to lessen the possibility of the brush contact with the slip ring being broken as the shaft rotated.

The maximum diameter of the torquemeter as set forth in the second design was $6\frac{1}{2}$ inches. This was $1\frac{3}{4}$ inches less than the initial design.

Figures 6 and 7 show the torquemeter with and without the protective cover.

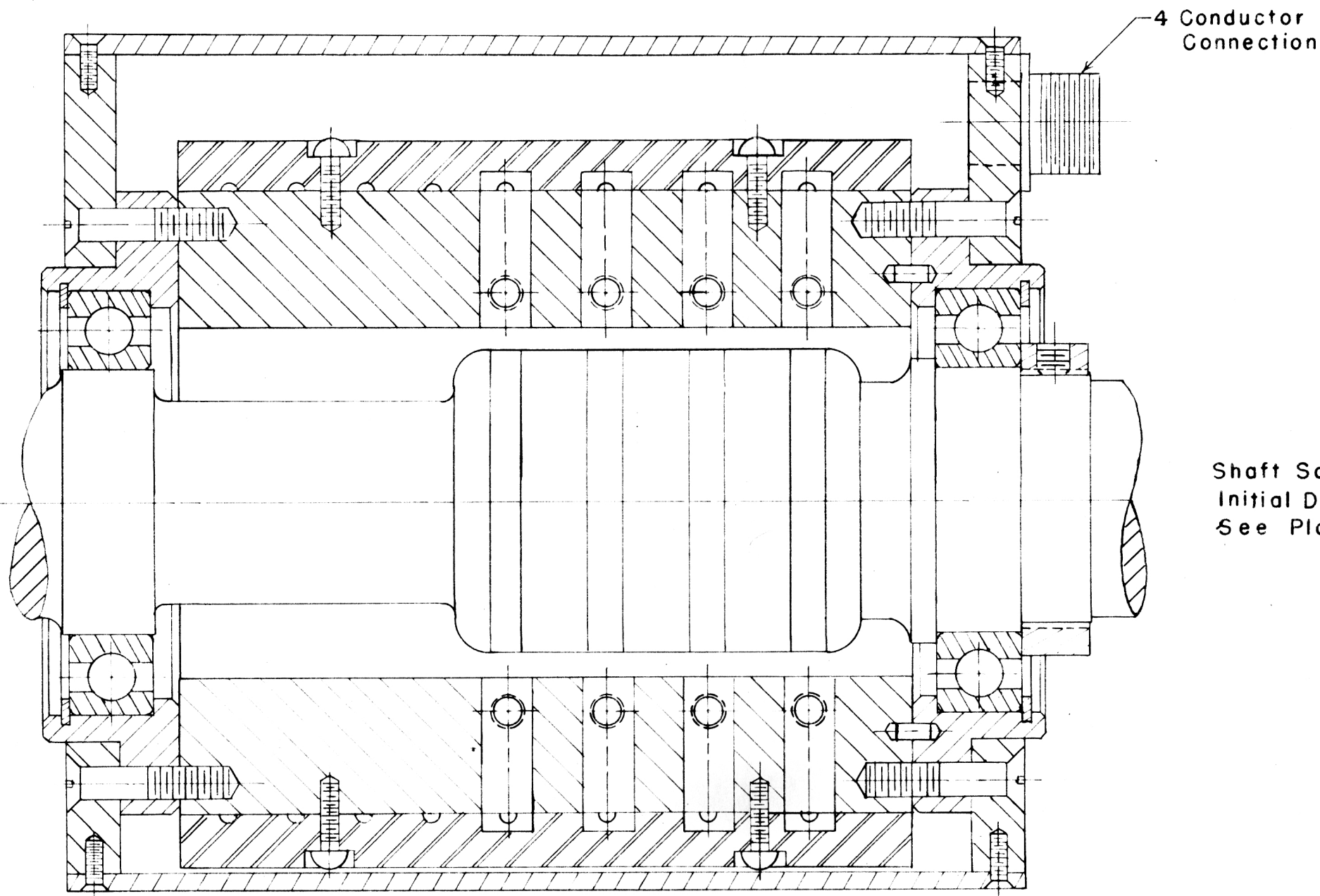

Fig. 5. Full size view of the brush holding device and silver graphite brush and spring.

EXPLANATION OF PLATE X

Cross section of the torquemeter after the design modification and detailed drawing of the brush holder support assembly.

PLATE X



Full Scale

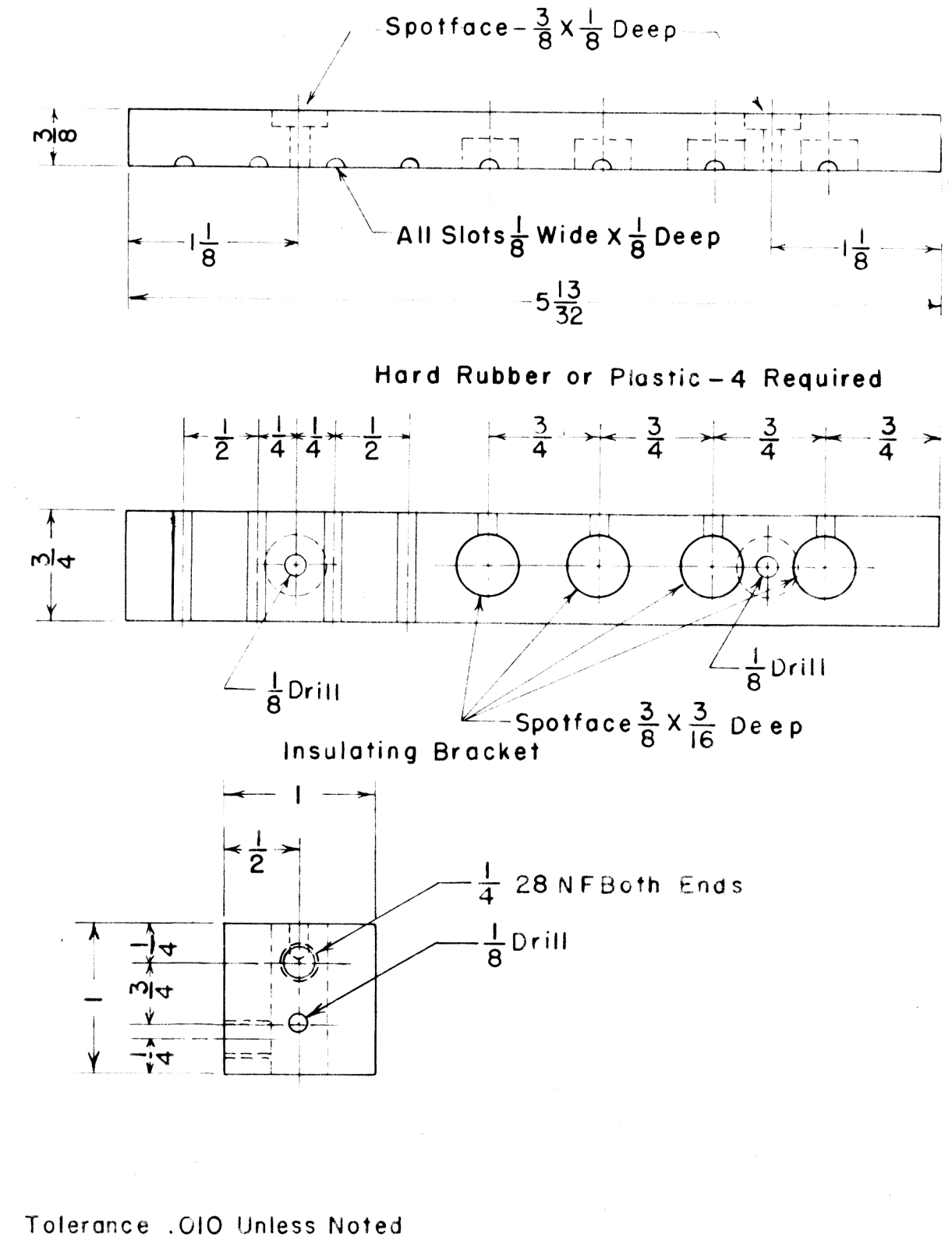
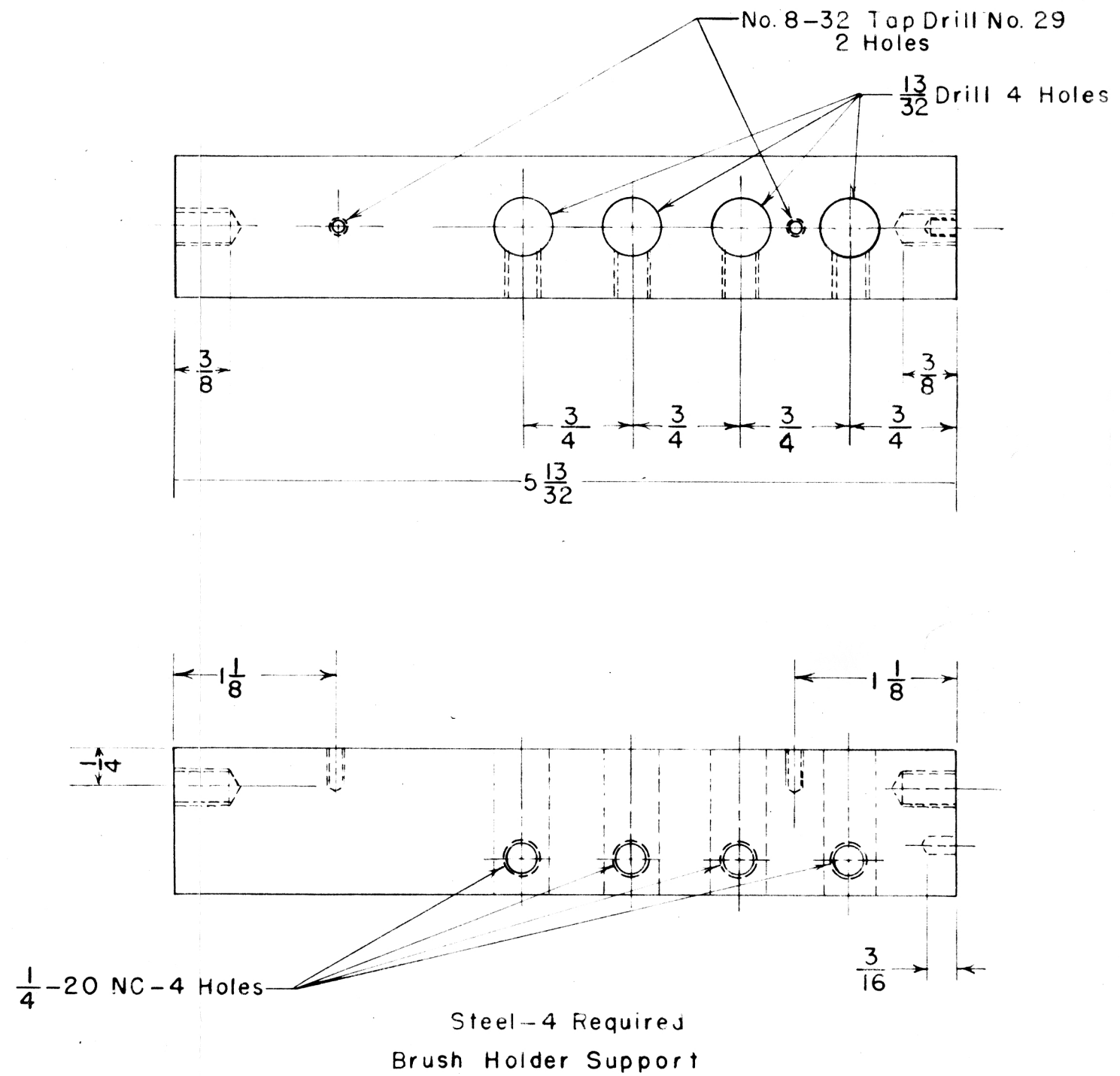

EXPLANATION OF PLATE XI

Detailed drawing of end plate and protective
cover.

PLATE XI

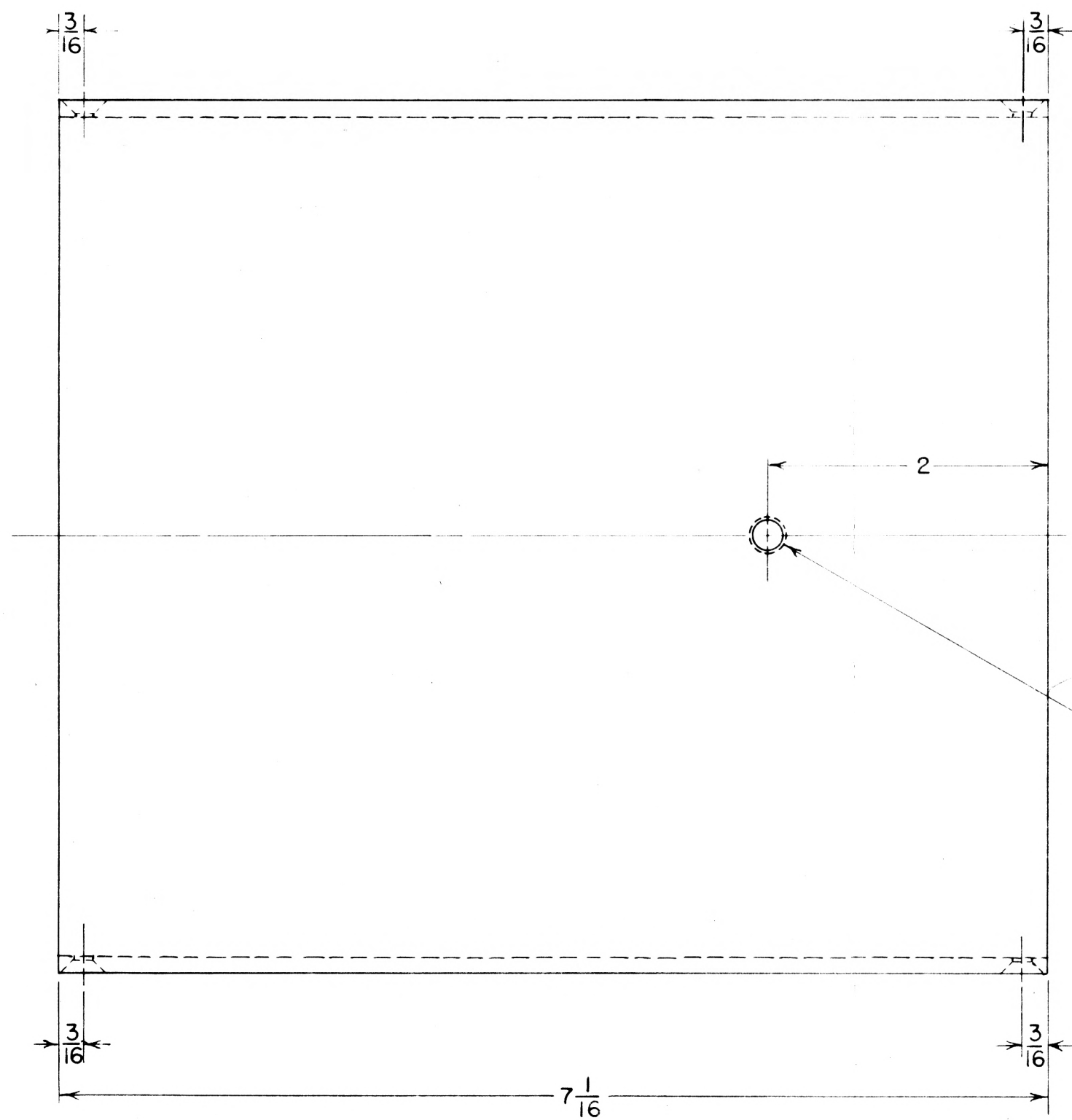

Protective Cover
Steel
1 Required

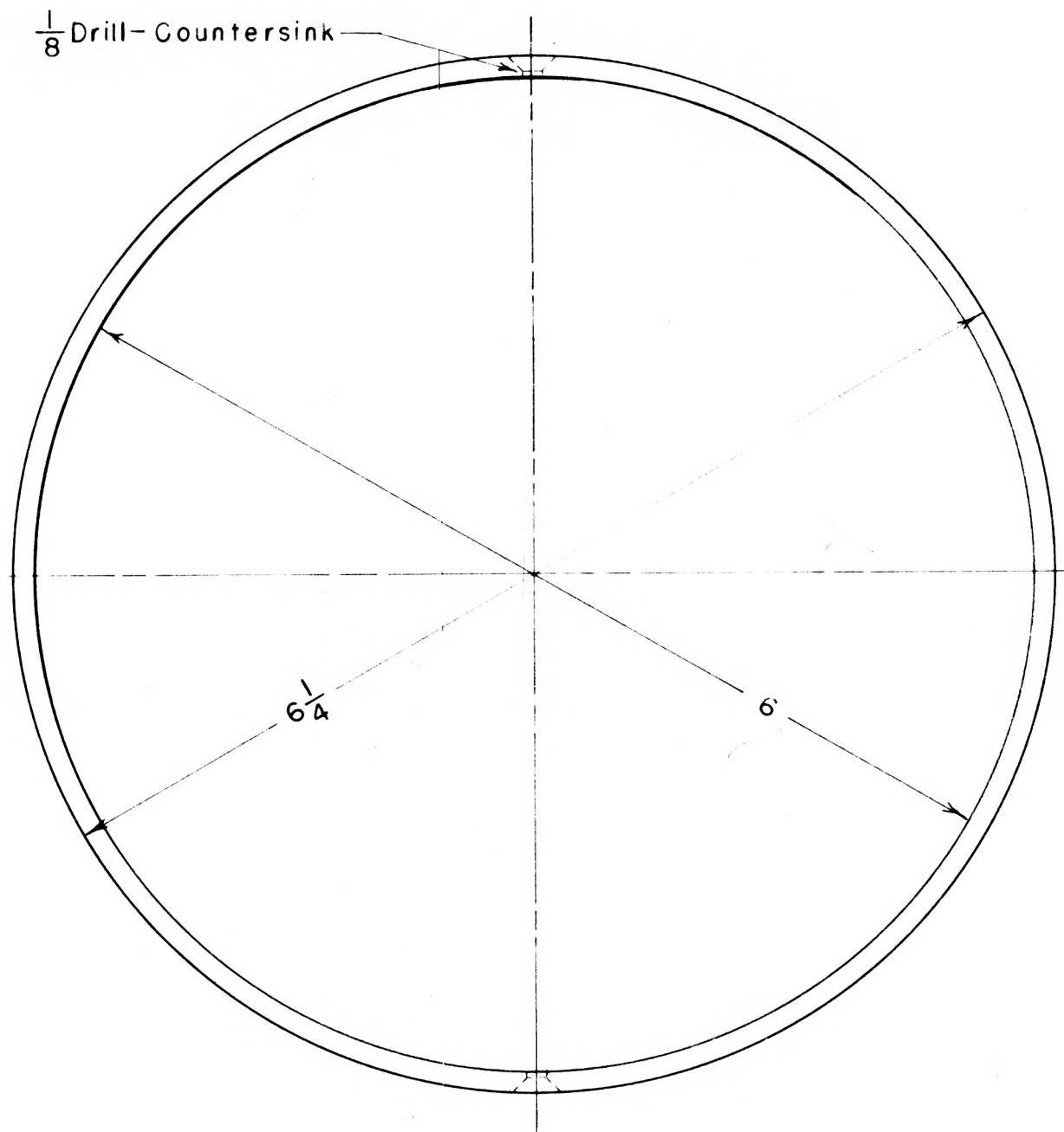

Full Scale

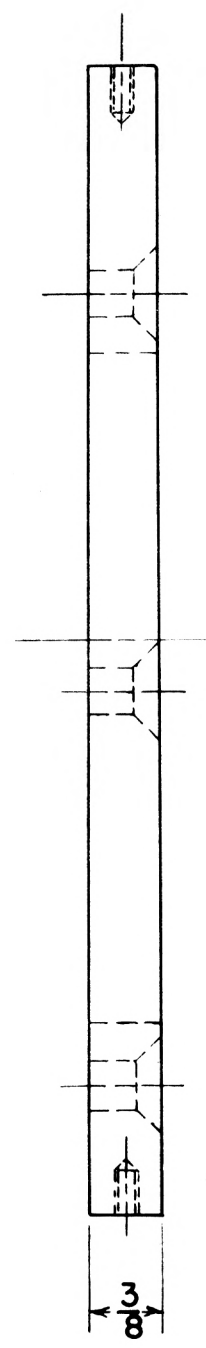

Tolerance .010 Unless Noted

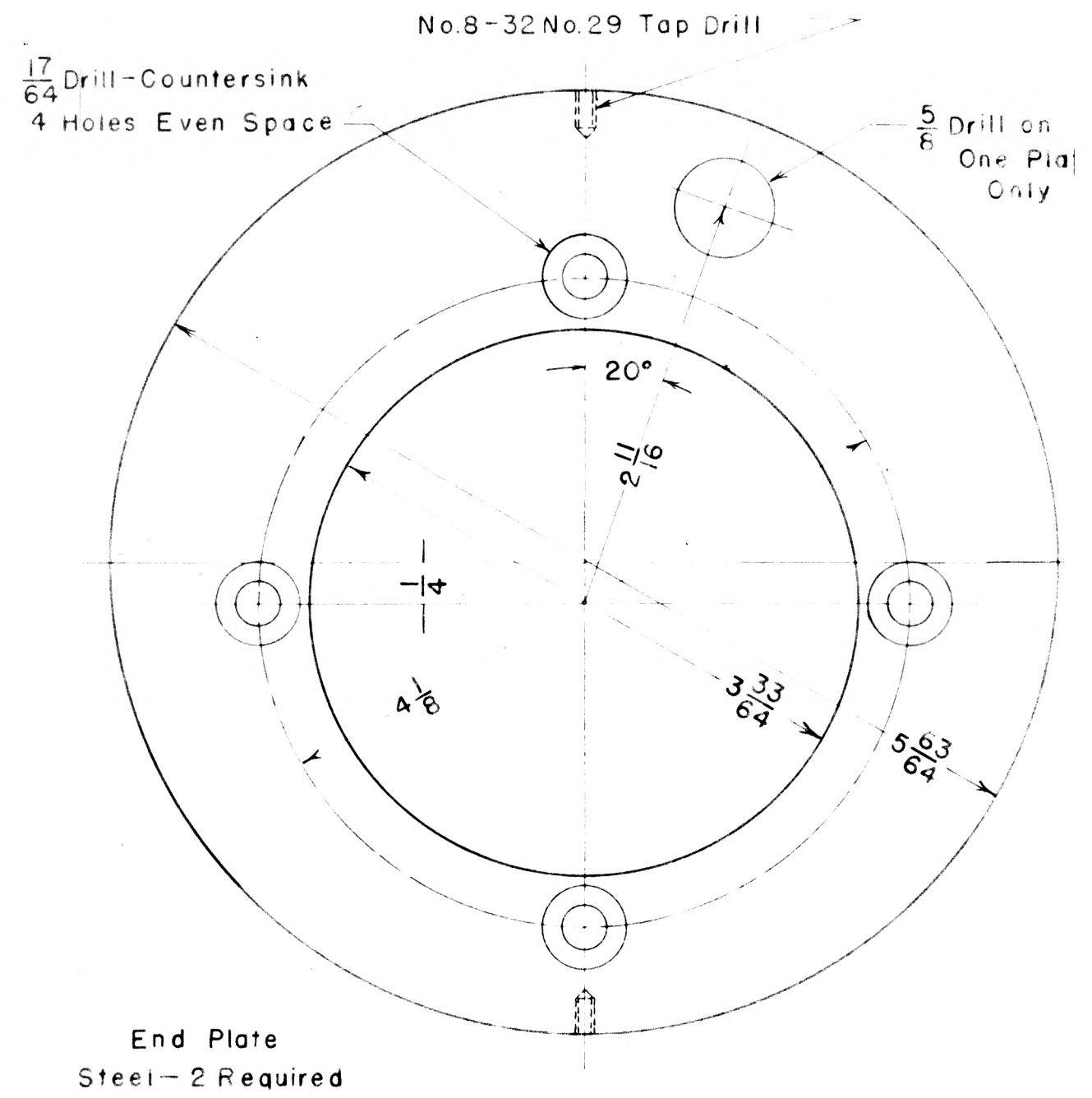

End Plate
Steel - 2 Required

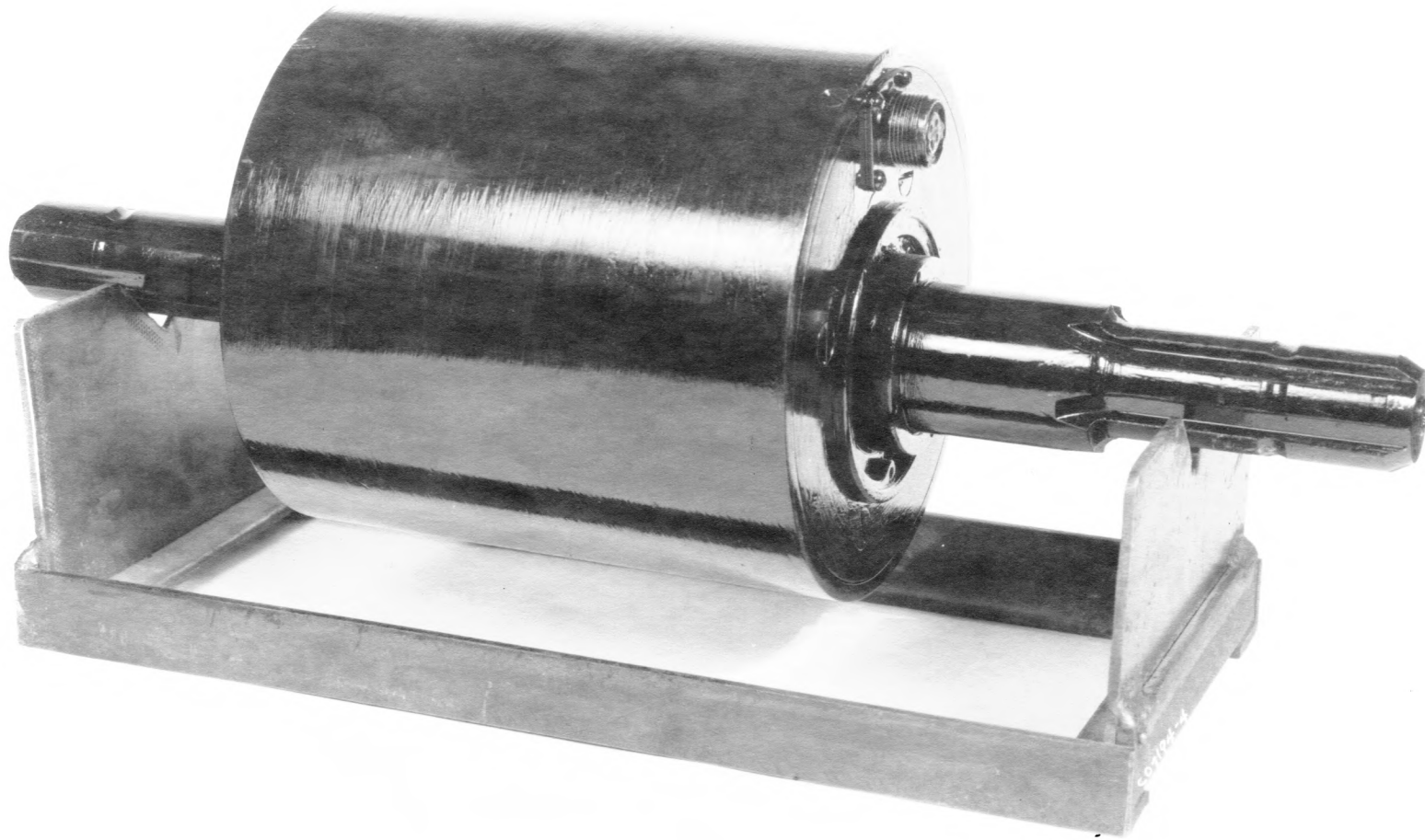

Fig. 6. The completed torquemeter with protective cover in place.

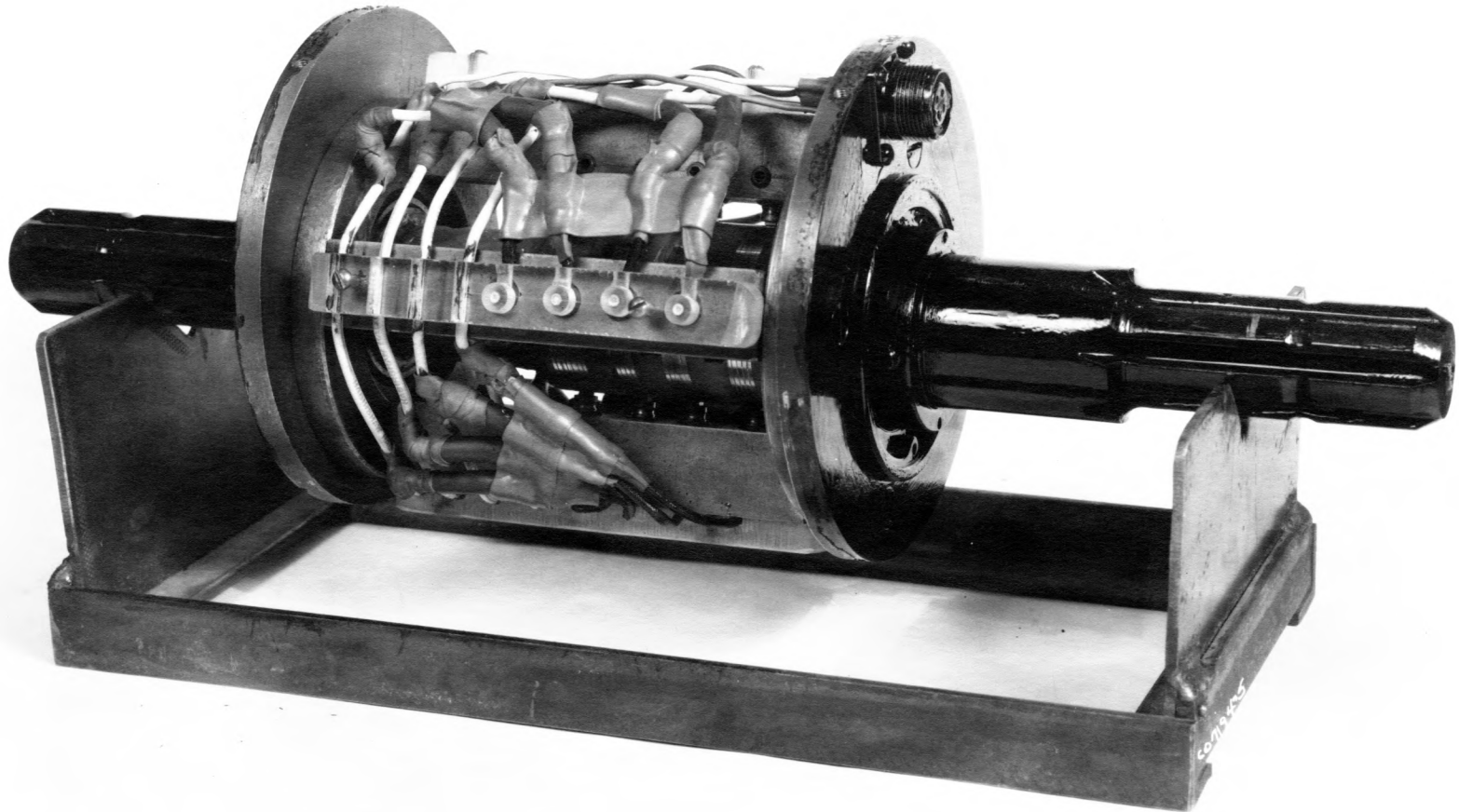

Fig. 7. The completed torquemeter without the protective cover.

Calculation of Torque

It has previously been stated that a round shaft subjected to pure torque is under a stress condition of pure shear. It has also been shown from Mohr's Circle for stress that equal tension and compression stresses act at an angle of 45 degrees in either direction from the direction of the shear stress. From this observation the following relationship can be written:

$$S_u = S_s = -S_v$$

where S_u is the principal stress in tension, S_s is the shear stress, and S_v is the principal stress in compression.

From Hooke's Law the following relationship can be written:

$$E \epsilon_u = S_u - \mu S_v$$

$$E \epsilon_v = -\mu S_u + S_v$$

where ϵ_u and ϵ_v are principal strains, and μ is Poisson's Ratio.

By the method of determinants the principal stresses can be obtained as:

$$S_u = \frac{\begin{vmatrix} E \epsilon_u & -\mu \\ E \epsilon_v & 1 \end{vmatrix}}{\begin{vmatrix} 1 & -\mu \\ -\mu & 1 \end{vmatrix}} = \frac{E \epsilon_u + \mu E \epsilon_v}{1 - \mu^2}$$

$$S_v = \frac{\begin{vmatrix} 1 & E \epsilon_u \\ -\mu & E \epsilon_v \end{vmatrix}}{\begin{vmatrix} 1 & -\mu \\ -\mu & 1 \end{vmatrix}} = \frac{E \epsilon_v + \mu E \epsilon_u}{1 - \mu^2}$$

Since $S_u = S_s = -S_v$, the following relationship can be written:

$$\frac{E \epsilon_u + \mu E \epsilon_v}{1 - \mu^2} = \frac{-(E \epsilon_v + \mu E \epsilon_u)}{1 - \mu^2}$$

$$\frac{E}{1 - \mu^2} (\epsilon_u + \mu \epsilon_v) = \frac{E}{1 - \mu^2} (-\epsilon_v - \mu \epsilon_u)$$

$$\epsilon_u + \mu \epsilon_v = -\epsilon_v - \mu \epsilon_u$$

$$\epsilon_u + \mu \epsilon_u = -(\epsilon_v + \mu \epsilon_v)$$

$$\epsilon_u (1 + \mu) = -\epsilon_v (1 + \mu)$$

$$\epsilon_u = -\epsilon_v$$

Since the strain gages were mounted on the shaft parallel to the lines along which the principal strains act, the strain in each gage is equal to one of the principal strains caused by the torque to which the shaft is subjected.

Since $\epsilon_u = -\epsilon_v$ and $S_u = S_s = -S_v$, it can be written that:

$$S_s = \frac{E \epsilon_u - \mu E \epsilon_u}{1 - \mu^2} = \frac{E \epsilon_u (1 - \mu)}{(1 - \mu)(1 + \mu)}$$

$$S_s = \frac{\epsilon E}{1 + \mu}$$

where ϵ is the strain in one gage.

It is also true that:

$$S_s = \frac{Tc}{J}$$

where T is the torque in inch-pounds, c is the radius of the shaft in inches, and J is the polar moment of inertia of the shaft in inches to the fourth power.

$$S_s = \frac{Tr}{\pi r^4} = \frac{2T}{\pi r^3}$$

By equating the two equations for shear stress, the following relationship can be written:

$$\frac{2T}{\pi r^3} = \frac{\epsilon E}{1 + \mu}$$

$$T = \frac{\epsilon E \pi r^3}{2(1 + \mu)}$$

For this torquemeter the following values can be written:

$$E \text{ for steel} = 30 \times 10^6 \text{ psi}$$

$$r = 0.75 \text{ inch}$$

$$\mu = 0.28$$

By substituting these values into the above equation, the value of the torque is found to be:

$$T = 15.5 \epsilon$$

where ϵ is in micro-inches per inch and T is in inch-pounds of torque.

Discussion of Instruments

It has been stated that the two instruments used to test the torquemeter were the Universal Brush amplifier BL 520 with input box BL 350 in conjunction with the BL 274 recording instrument, and the Baldwin SR-4 strain indicator.

The Brush Amplifier

The Brush oscillograph was used to record the strain indications from fluctuating loads. The instruments were set up according to operating instructions furnished by the manufacturer of the instruments.

The torquemeter has four lead wires. The red wire is the input voltage to the bridge circuit. The blue wire is the ground and is grounded directly to the rotating shaft to carry off any static charge which might build up on the slip rings. The green and white wires are the bridge output voltage and provide the oscillator drive voltage.

The torquemeter lead wires are connected to the input box terminal, as illustrated in Fig. 8.

1. The red wire is connected to terminal No. 2 which is the input to the carrier amplifier.
2. The blue wire is connected to terminal No. 3 which is the ground.
3. The white and green wires are connected to terminals 1 and 4 respectively.

If it is desirable to have the recording pen deflect in the opposite direction, it is necessary to interchange the white and green lead wires on terminals 1 and 4.

The system is balanced according to instructions given in Operating Instructions ED 31207 furnished with input box BL 350.

After balancing the system it is necessary to calibrate the instrument for the particular resistance and gage factor being used.

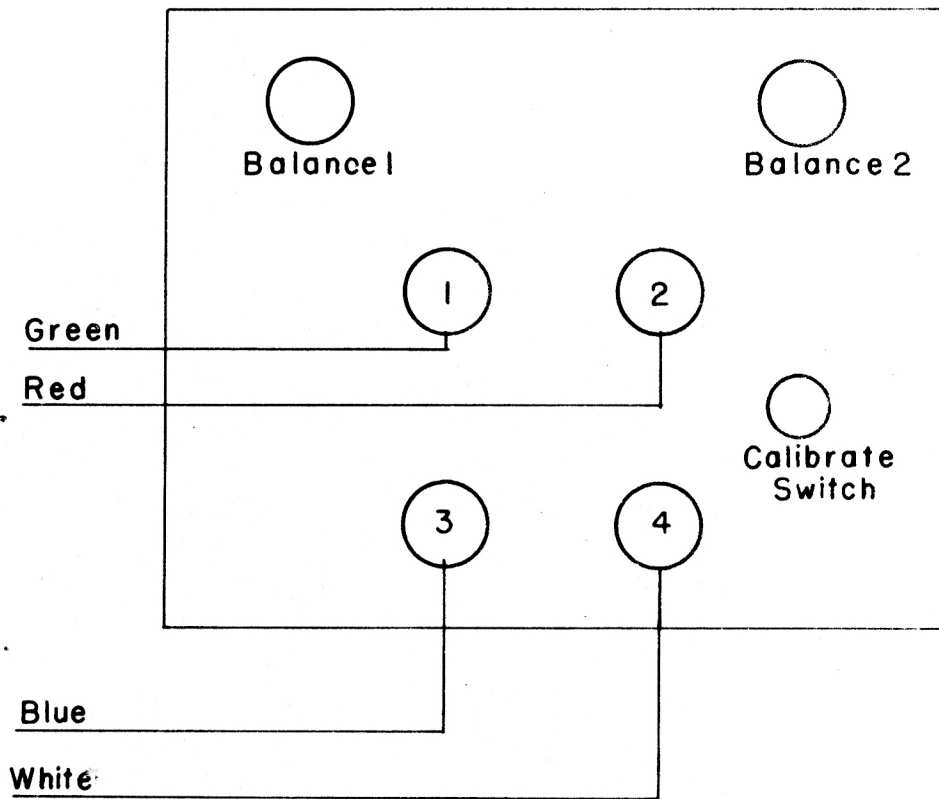

Fig. 8. Diagram of how torquemeter lead wires are connected to the input box of the Brush amplifier.

The system is calibrated using a calibration constant of 372 attenuator lines. This value is in disagreement with the calibration constant as computed by equation (2) on page 5 of Operating Instructions ED 31207 which were furnished by the instrument manufacturer.

The equation mentioned above appears as follows:

$$K_c = \frac{N \times R}{(S) F_m (R_c + R)}$$

where K_c is the calibration constant in attenuator lines

S is the strain sensitivity per attenuator line

N is the number of active gages

R is resistance of the strain gage

F_m is the gage factor

R_c is the calibration resistance (390K ohms)

The calibration constant is obtained by substituting into the equation the following values:

$N = 4$ active gages

$S = 1 \times 10^{-6}$ inch per inch of strain per attenuator line

$R = 500$ ohms

$F_m = 3.43$

$R_c = 390,000$ ohms

$$K_c = \frac{4 \times 500}{1 \times 10^{-6} \times 3.43(390.5 \times 10^3)}$$

$K_c = 1,490$ attenuator lines

When this value was used for calibration, the torque as measured by the torquemeter was greater than the torque applied by a factor of four.

It is believed that the equation for the calibration constant should be as follows:

$$K_c = \frac{l \times R}{S F_m(R_c + R)}$$

$$K_c = \frac{500}{1 \times 10^{-6} \times 3.43(390.5 \times 10^3)}$$

$$K_c = 372 \text{ attenuator lines}$$

When this value was used for the calibration constant, the torque as measured was equal to the torque applied.

The value of the strain measured by this instrument is equal to the number of lines of pen deflection times the attenuator lines.

This torquemeter has the complete bridge circuit mounted on the rotating shaft for reasons already stated.

All four gages are active and are arranged so that the tension gages are opposite each other in the bridge and the compression gages are also opposite each other in the bridge. This arrangement causes the instrument to read a strain which is four times the actual strain in one gage.

The strain in one gage is therefore:

$$\epsilon = \frac{\text{attenuator lines}}{4}$$

where ϵ is in micro-inches per inch.

The indicated torque is:

$$T = \frac{\text{attenuator lines}}{4} \times 15.5$$

where T is in inch-pounds of torque.

The brush amplifier, input box, and recording oscillograph are shown in Fig. 9.

The SR-4 Strain Indicator

The SR-4 strain indicator was used on the static test of the torque meter and also on dynamic loads which were steady enough to allow the instrument to be balanced.

The torque meter leads are connected to the SR-4 indicator as shown in Fig. 10. The white and green wires may be interchanged if desired.

Since the gage factor dial on the SR-4 indicator does not include a gage factor of 3.43, it was necessary to calculate a new gage factor. The new gage factor was taken from Fig. 3, page 5, of the operating instructions for the instrument as 1.976. The strain indicated by the instrument must be multiplied by two divided by the original gage factor.

Strain readings were taken as outlined in the operating instructions for the instrument. The strain indicated by the SR-4 indicator is again four times the strain in one gage, for reasons previously stated.

The indicated torque is calculated by the following formula:

$$T = \epsilon \times 15.5$$

$$\epsilon = \frac{(D_1 - D_2)}{4} \times \frac{2}{3.43}$$

$$T = \frac{(D_1 - D_2)}{4} \times \frac{2}{3.43} \times 15.5$$

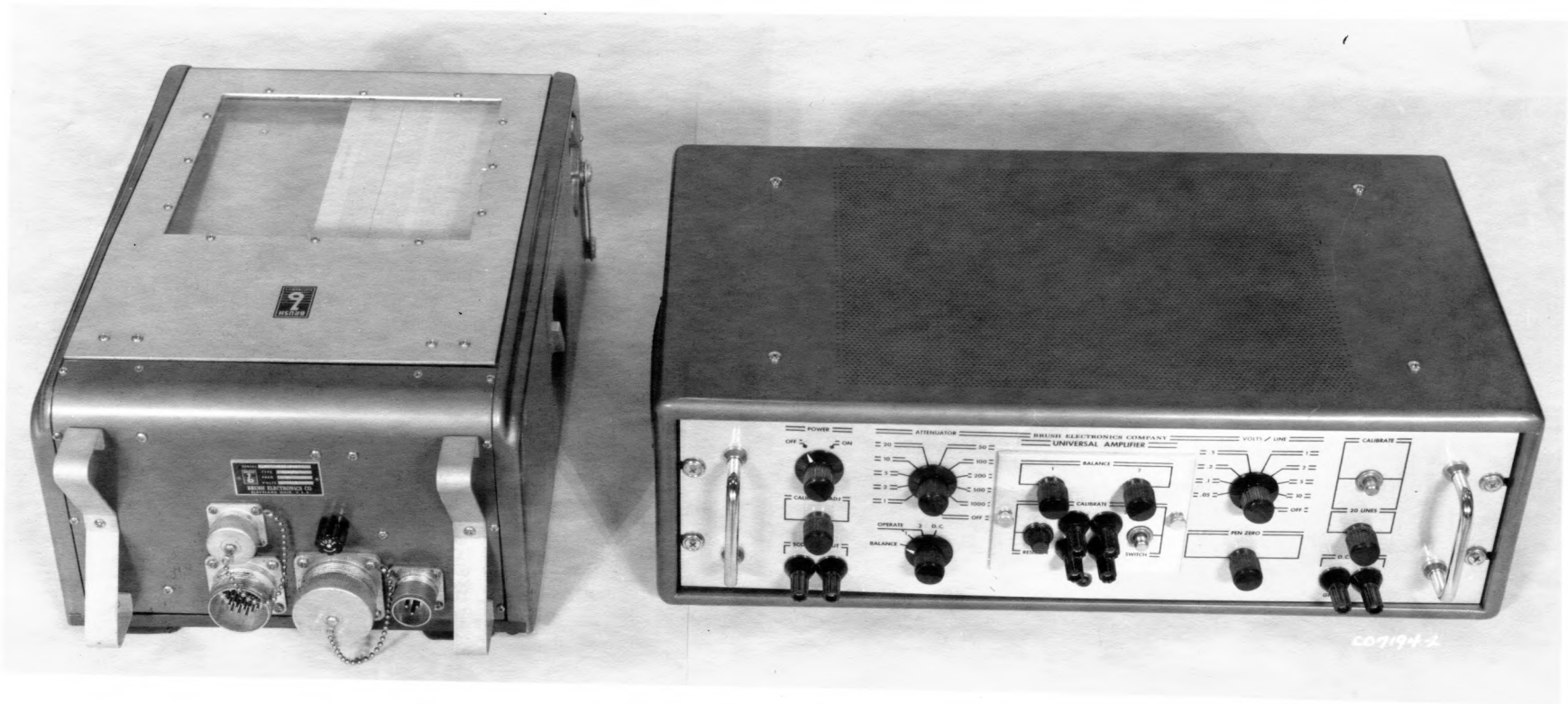

Fig. 9. Brush oscillograph on the left, and Brush amplifier and input box on the right.

Page 59 is missing in the original thesis.

$$T = (D_1 - D_2) \times 2.26$$

where $D_1 - D_2$ represents the difference in the dial readings taken before and after loading.

The SR-4 indicator is shown in Fig. 11.

TESTING THE TORQUEMETER

Static Test

The torquemeter was tested under a static load to determine its accuracy. Both the Brush amplifier and the SR-4 strain indicator were used in these tests.

A measured torque was applied to the torquemeter with the shaft in a stationary position. Readings were taken from the instruments, and the torque was calculated from the observed readings. The calculated torque was compared with the measured torque applied and the per cent of error was calculated. Average values of the per cent of error were plotted against the amount of torque applied. The curve obtained is shown in Fig. 12.

From this curve it can be seen that the torque indicated by the torquemeter may be in error by an amount of 5 per cent or more if the torque is 800 inch-pounds or less.

Two methods of applying the measured torque were employed. In the first method, one end of the torquemeter shaft was clamped in a vise. A 40-inch lever was fastened to the other end of the shaft, and varying weights were applied to the lever at ten-inch length intervals. It was possible to vary the amount of torque



Fig. 11. The Baldwin SR-4 strain indicator.

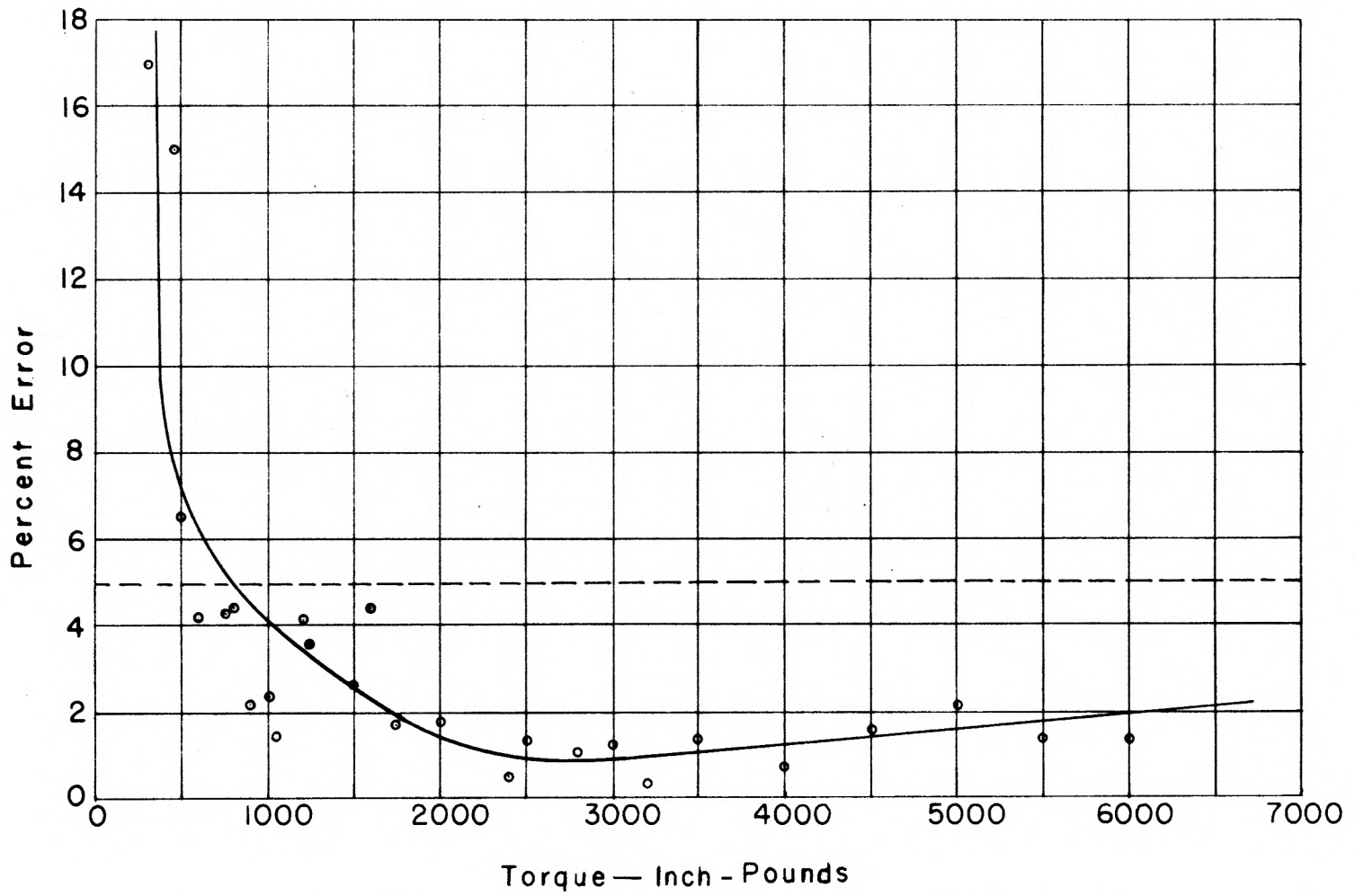

Fig. 12. A curve showing the per cent of error obtained from the static test plotted against the applied torque.

applied from 300 inch-pounds to 3,200 inch-pounds. The Brush amplifier was used in this test. Figure 13 shows a comparison between the torque applied and the torque indicated by the torque-meter. It is again apparent that the values are more in disagreement at lower torques.

The torquemeter was tested to make sure all bending moments were canceled by applying a bending moment to the shaft with no torque applied, and observing that the balance of the bridge circuit was not disturbed.

Torque was applied in the second method by placing the torquemeter in a Tinius Olsen torque machine. Torques were applied with this machine which varied from 500 to 6,000 inch-pounds. It was difficult to keep the clamping jaws of the machine from slipping on the torquemeter shaft at the higher torque values. It was for this reason that torque values greater than 6,000 inch-pounds were not applied. The SR-4 strain indicator was used in this test. Figure 14 shows a comparison between the torque applied by the Tinius Olsen machine and the torque indicated by the torquemeter.

Comparison between Values Obtained from a Dynamometer and the Torquemeter

The torquemeter was placed in the power shaft between an engine and a hydraulic dynamometer, and the torque values indicated by the torquemeter were compared to the values indicated by the dynamometer.

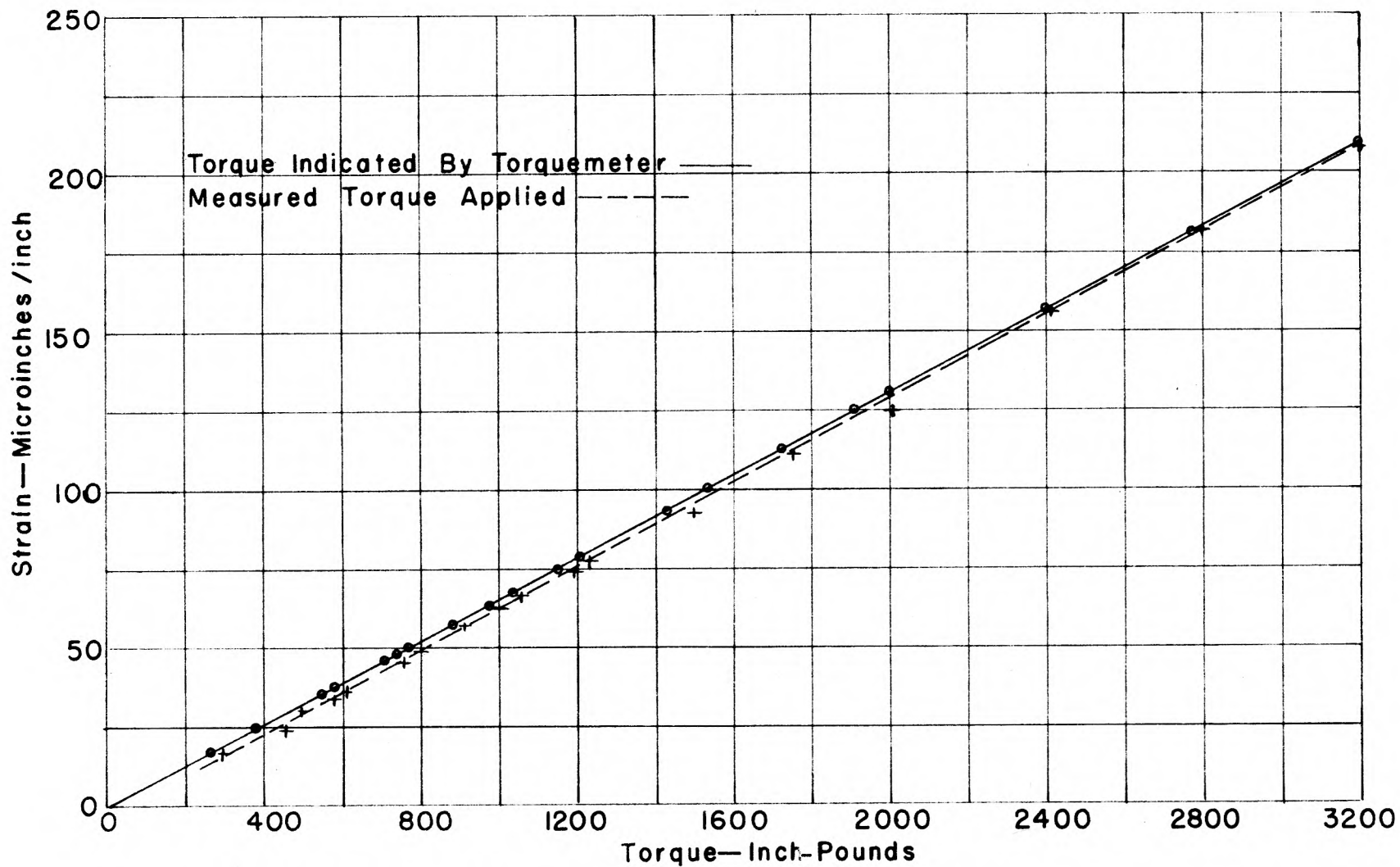

Fig. 13. A comparison between the torque indicated by the torquemeter and the measured torque applied in the static test. The Brush amplifier was used to measure strain.

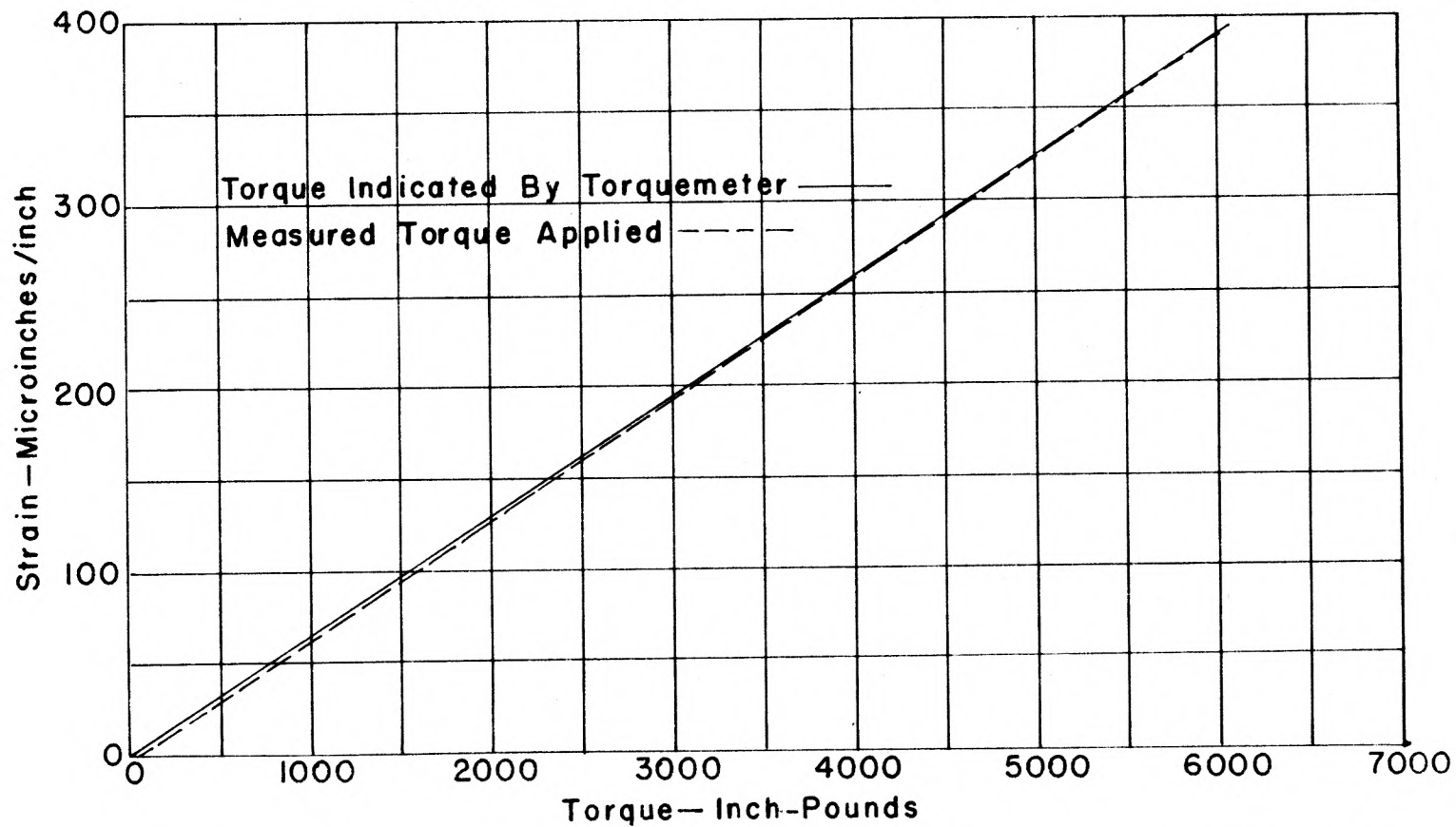

Fig. 14. A comparison between the torque indicated by the torquemeter and the measured torque applied in the static test. The SR-4 strain indicator was used to measure strain.

Figure 15 shows a comparison between the values of torque indicated by the torquemeter and the dynamometer when the Brush amplifier was used to record torque indications from the torquemeter.

The per cent of error was not computed because the degree of accuracy of the dynamometer was not known.

Plate XII shows typical data taken while the engine was running at various speeds.

Figure 1 shows data taken at a chart speed of 250 millimeters per second and an engine speed of 1,050 revolutions per minute.

Figure 2 shows the same engine speed at a chart speed of 125 millimeters per second.

Figure 3 shows the same engine speed at a chart speed of 50 millimeters per second.

At certain engine speeds the data were smoother than at other speeds. Figure 4 shows data taken at 1,450 revolutions per minute and a chart speed of 2 millimeters per second.

It is believed that the difference in the data can be attributed to the torsional vibration characteristics of the system at different speeds.

An Application of the Torquemeter

The torquemeter was used to determine the efficiency of an irrigation pump and of the pump engine. The torquemeter was installed in the power shaft between the engine and the pump,

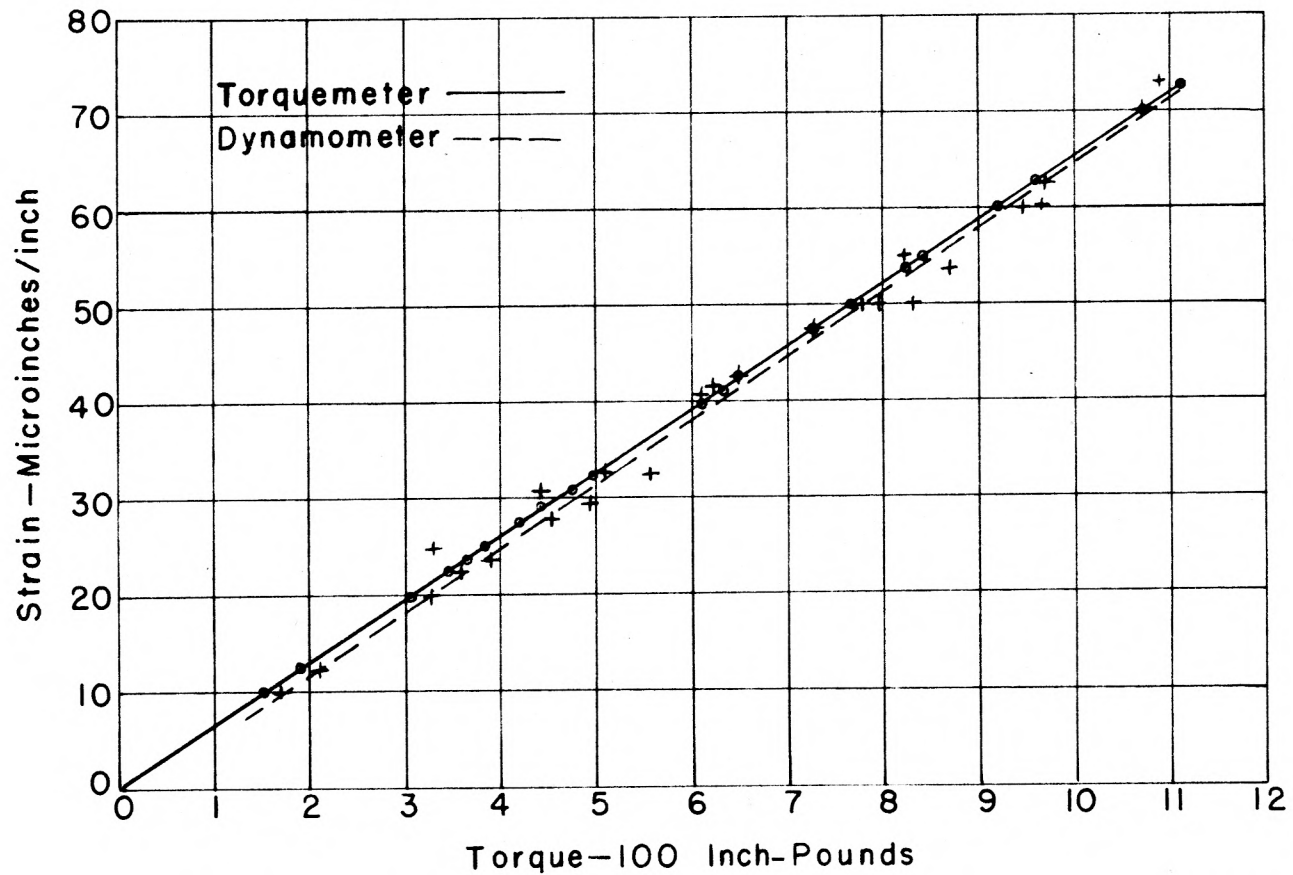

Fig. 15. A comparison between the torque indicated by the torque-meter and the torque indicated by a dynamometer. The Brush amplifier was used to measure strain.

EXPLANATION OF PLATE XII

Fig. 1. Data taken at a chart speed of 250 mm per second and an engine speed of 1,050 rpm.

Fig. 2. Data taken at same engine speed as in Fig. 1 but at a chart speed of 125 mm per second.

Fig. 3. Data taken at same engine speed as in Fig. 1, but at a chart speed of 50 mm per second.

Fig. 4. Data taken at an engine speed of 1,450 rpm and a chart speed of 2 mm per second.

PLATE XII

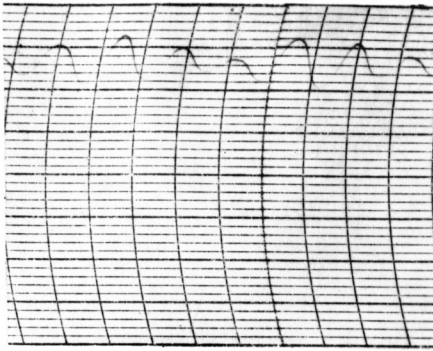

Fig. 1.

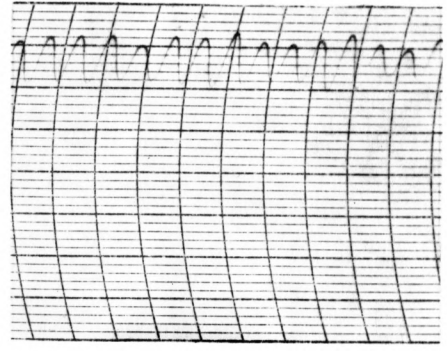

Fig. 2.

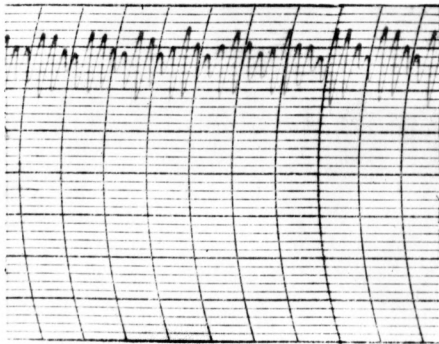

Fig. 3.

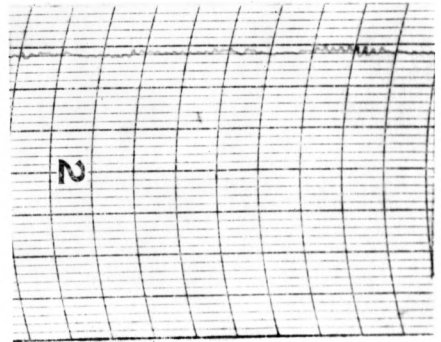

Fig. 4.

as illustrated in Fig. 16.

During the test the engine speed was varied from 1,775 rpm to 2,230 rpm, and the torque varied from 1,007 inch-pounds to 1,920 inch-pounds.

Fuel consumption was measured and horsepower input was determined from the heat content of the fuel. The engine efficiency varied from 13.9 per cent at the lowest speed to 21.1 per cent at the highest speed.

The quantity of water pumped and the pumping head were measured. The water horsepower output of the pump was then calculated. The pump varied in efficiency from 54.3 per cent at the lowest speed to 43.8 per cent at the highest speed.

It was observed that the pump efficiency was highest when the engine efficiency was lowest.

The purpose of this test was to establish a procedure for using the torquemeter in tests of this kind.

RECOMMENDATIONS FOR FURTHER STUDY

The torquemeter which was designed and built for this study has several faults. It is believed that these faults, which are a matter of design, are important enough to warrant further study.

These faults are:

1. Excessive weight
2. Excessive length
3. Difficulty of removing the shaft



Fig. 16. The torquemeter installed between an irrigation pump and its power source.

4. Tendency for the wire-wound slip rings to unwind from the shaft.

An improved design is suggested in the detailed drawings in Plates XIII, XIV, and XV.

The proposed torquemeter will correct several of the faults of the one which was built and tested.

1. The proposed torquemeter is to be nearly six inches shorter than the original. The overall diameters are approximately the same.

2. The proposed torquemeter will be much lighter in weight since most of the parts are to be made of aluminum.

3. It will be much easier to remove the shaft from the proposed torquemeter. This will make it possible to change the capacity more easily. The capacity of the torquemeter may be changed by making shafts which have different diameters in the torque measuring section.

4. Silver bands butt soldered with silver solder are specified for the slip rings instead of the soft soldered silver wire-wound rings. This is to eliminate the danger of the wire coming loose from the binding material on the shaft. The slip rings may be installed in much the same manner as were the wire-wound rings.

It will be necessary to mount terminal strips on the shaft so the strain gage leads may be disconnected from the slip rings easily. These terminal strips may be secured to the shaft with Armstrong's A-1 cement.

The tube upon which the slip rings are to be mounted must be

EXPLANATION OF PLATE XIII

Cross section of the proposed torquemeter design
and silver slip ring details.

PLATE XIII

Circular Collector Wires Supported By Plastic Rings

Brush Holders—See Fig. 5.

Use Armstrong's A-1 Cement. Apply As in Plates VIII And IX
Turn First Layer To Exact I.D. Of Silver Rings

Use Armstrong's A-1 Cement To Fasten Terminal Strips To Shaft
One Strip On Each Side—2 Conductor Per Strip

4 $\frac{5}{16}$ Allen Set Screws With Full Dog Point

See Detailed Drawing For Position Of External
Electrical Connection

Use Sheet Metal For Cover

Use FAFNIR Bearing No. 9112PP

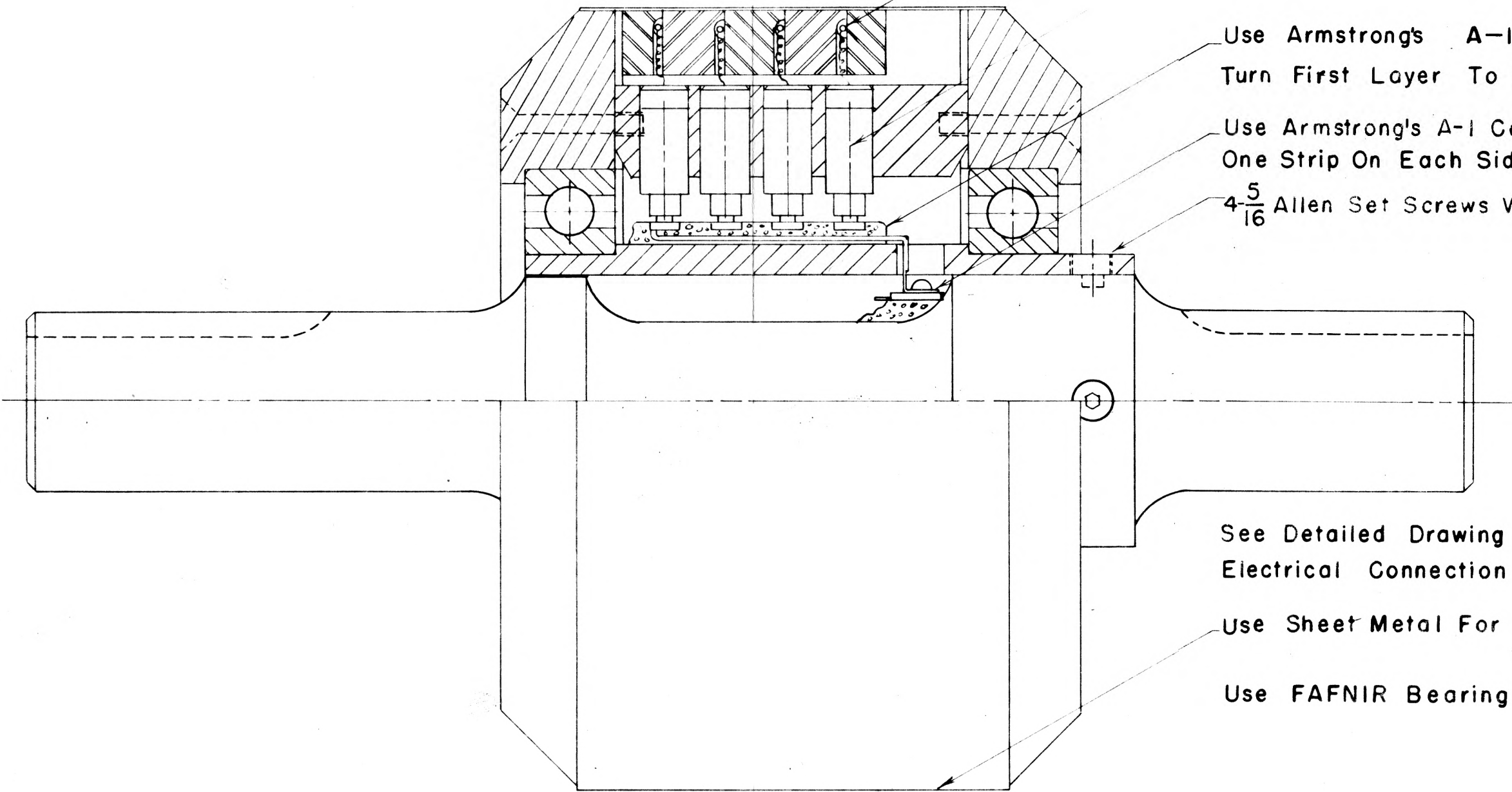

Silver Solder

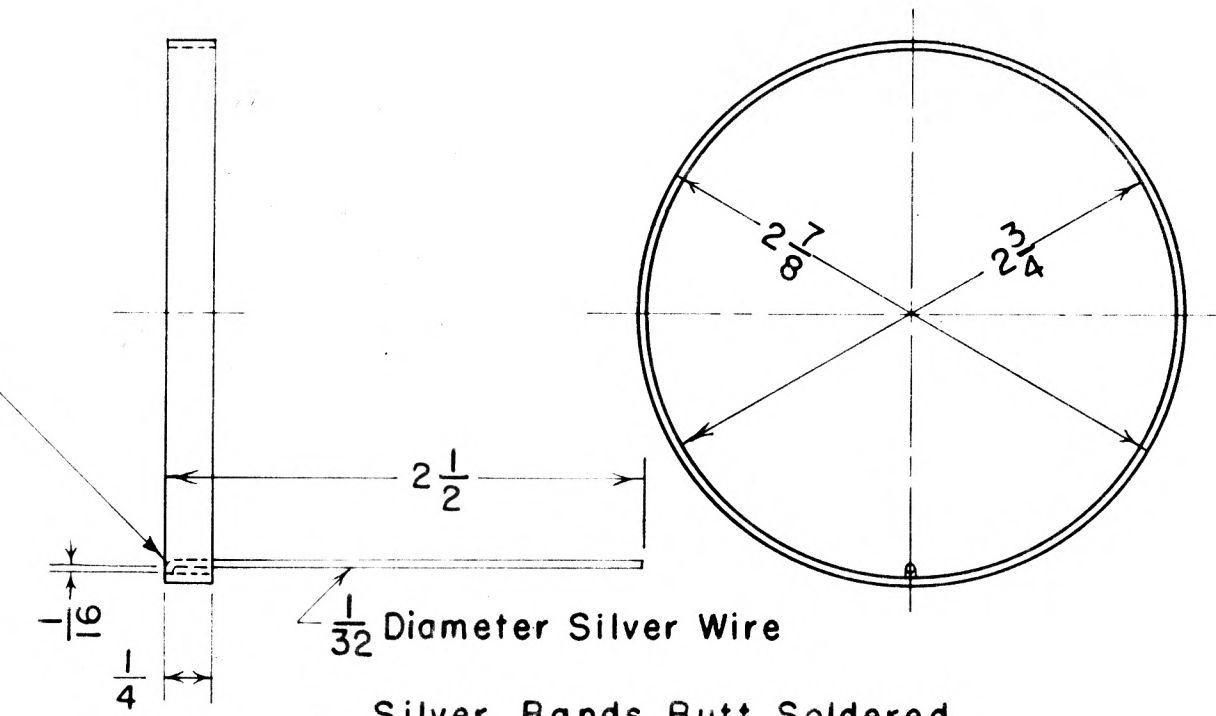

4 Required
Full Scale
Tolerance .010

EXPLANATION OF PLATE XIV

Detailed drawings of end plate and plastic
wire support ring.

EXPLANATION OF PLATE XV

Detailed drawings of torque shaft, slip ring support, and brush holder support.

PLATE XV

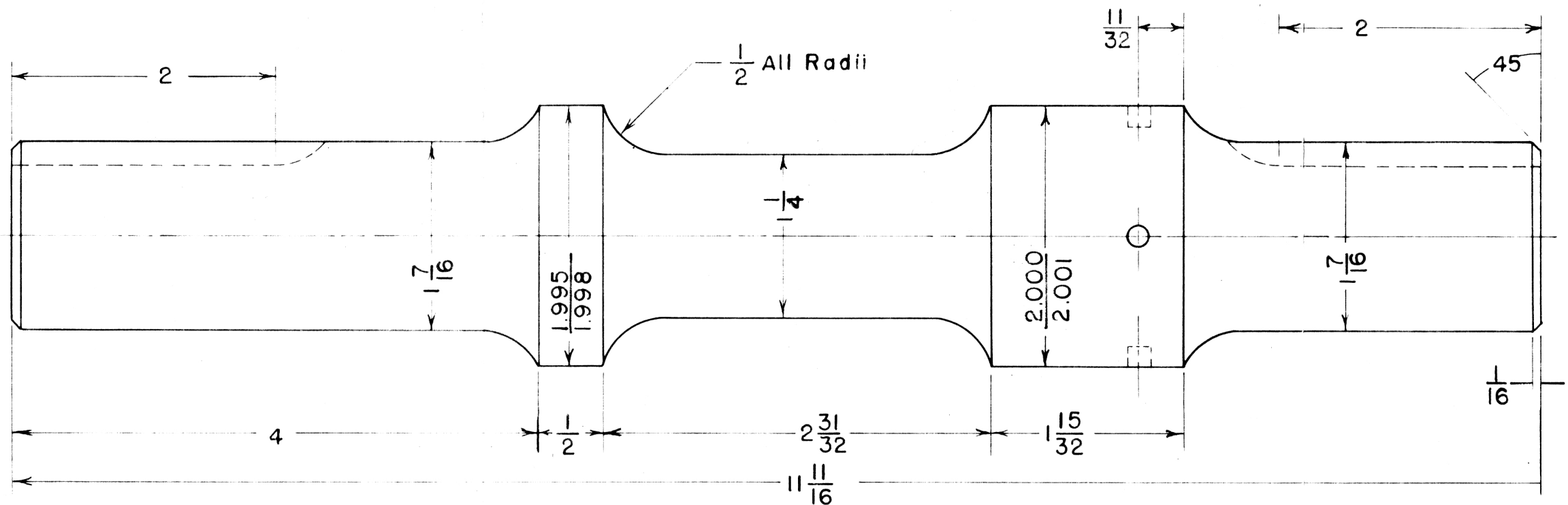
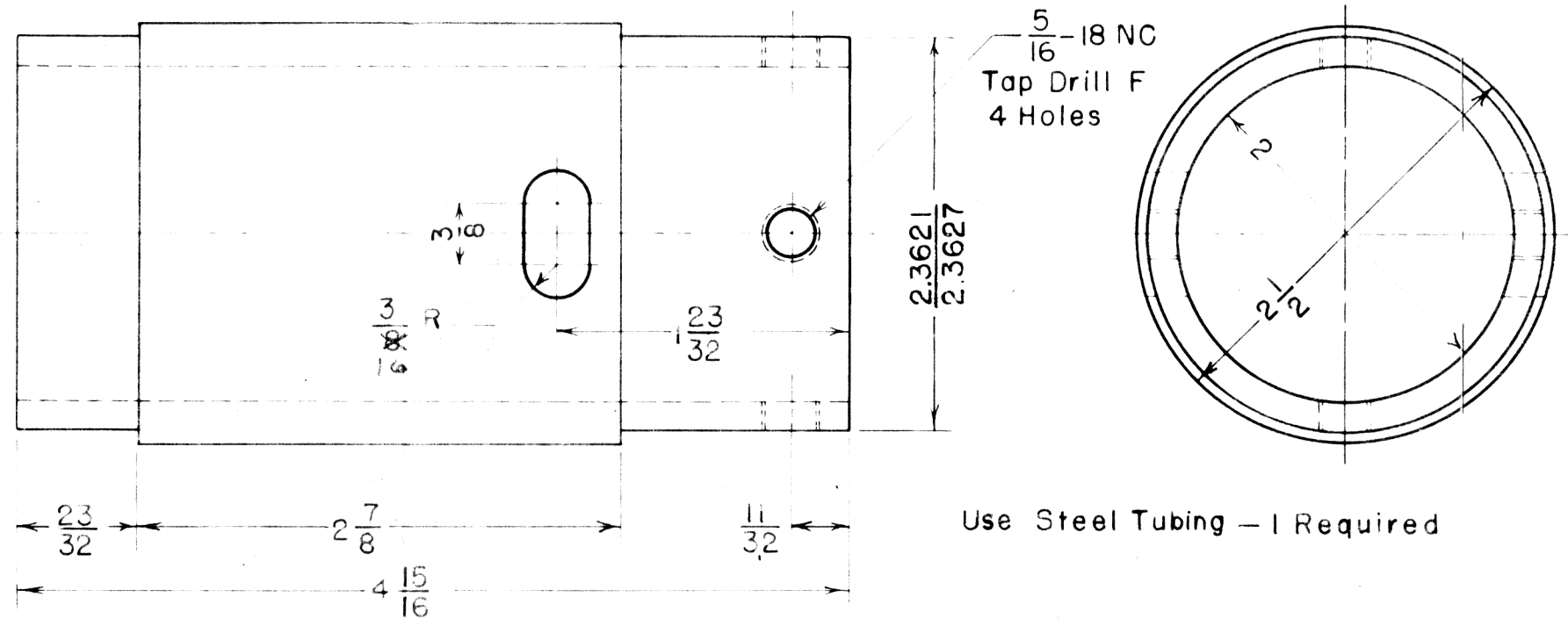

Steel - SAE 4340
 1 Required
 Torque Shaft

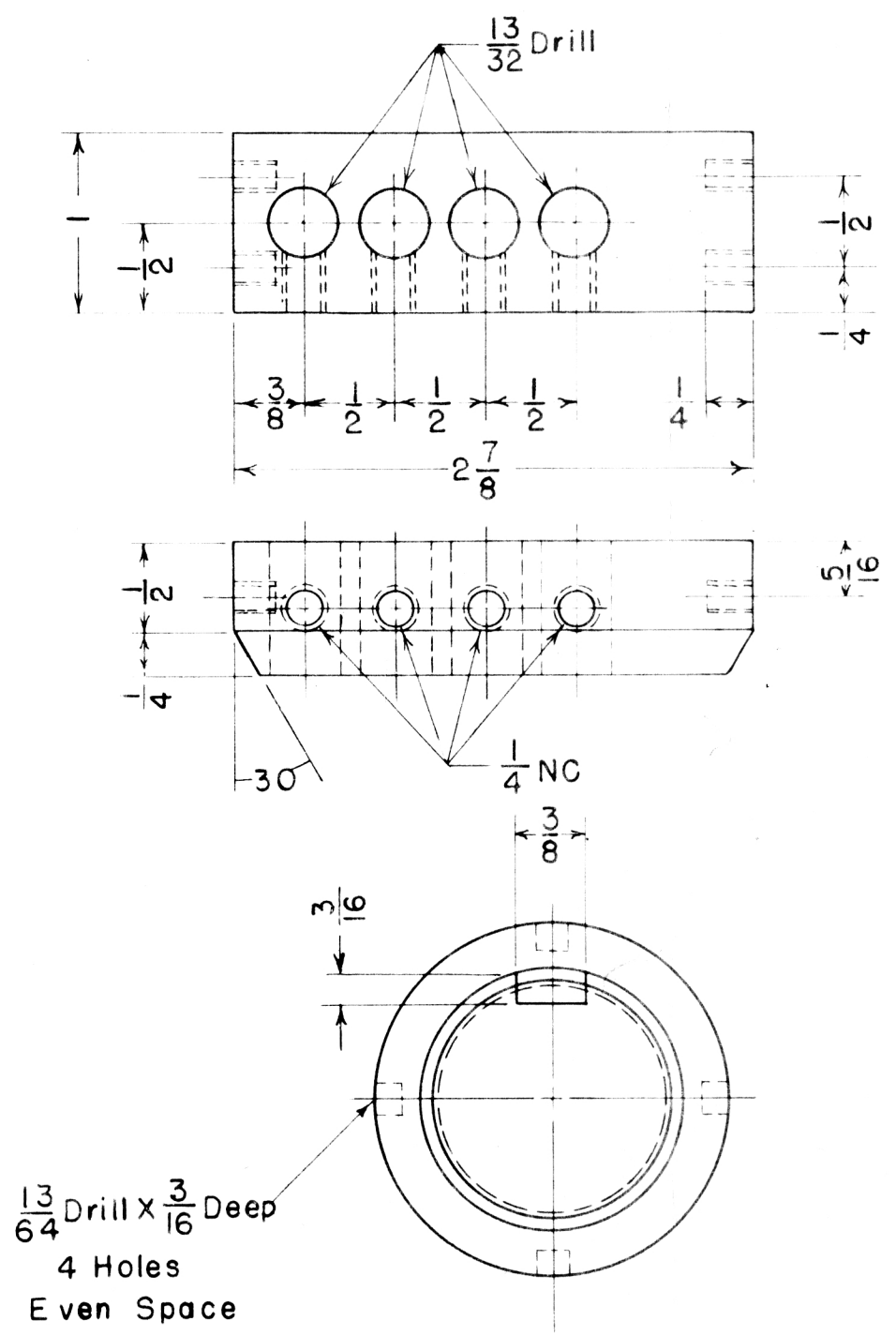

Brush Holder Support
 Aluminum
 4 Required

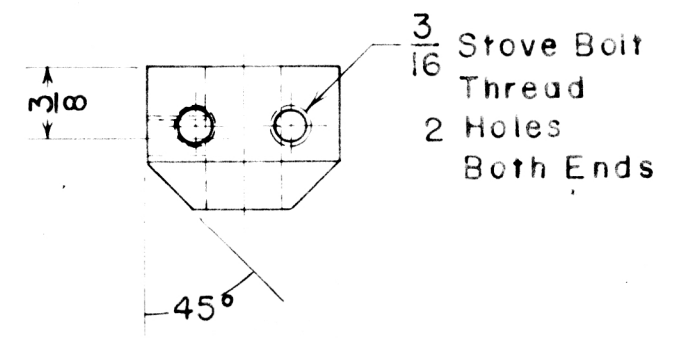

Full Scale
 All Tolerances .010
 Unless Noted

keyed to the shaft at one end and free at the other end. This will prevent the tube from carrying any of the torque load.

The wiring system for the strain gages is the same as for the original torquemeter.

Surfacing and polishing techniques for the slip rings are also the same.

The external electrical connection may be any type positive-locking, four-conductor connector.

CONCLUSIONS

The data obtained from this study support the following conclusions:

1. The torquemeter can be expected to give satisfactory results at varying speeds and at torque values of not less than 800 inch-pounds. If the torque is kept above 800 inch-pounds, the per cent of error can be expected to be less than 5 per cent. The torque value may be allowed to go up to 15,000 inch-pounds without damaging the torquemeter.

The torquemeter gave satisfactory results at speeds varying from 0 to 2,230 revolutions per minute.

2. The soldered silver wire-wound slip rings gave no trouble except in construction. Much difficulty was experienced in keeping the solder which held the slip rings from melting when the strain gage leads were soldered to them.

The ends of the silver wires have a tendency to come loose and protrude. This tendency caused no trouble, but the wire

might unwind completely in time. The wire should be held in place with silver solder instead of soft solder.

Armstrong's A-1 cement gave excellent results as a binding material for the slip rings and as moisture-proofing material for the strain gages. It showed no tendency to soften or crack.

3. The weight of the torquemeter was 39.5 pounds and the overall length was 18 inches. It would be a decided advantage if the torquemeter were shorter and lighter in weight. The proposed torquemeter design in Plates XIII, XIV, and XV is approximately six inches shorter, and will be lighter because most of the parts are of aluminum.

4. The iso-elastic wire strain gages were very satisfactory for the measurement of strain.

5. From Fig. 15 it can be seen that the torque values obtained from a dynamometer and those obtained from the torquemeter are in close agreement. These values were at the lower limit of the range of the torquemeter and at the upper limit of the range of the dynamometer. No percentage of error was calculated because the degree of accuracy of the dynamometer was not known.

It would be an advantage if the capacity range of the torquemeter could be changed by changing the torque measuring section of the shaft. The suggested design will make this feature possible.

6. Results of this study indicated that the torquemeter can be built for approximately 200 dollars, not including labor. It is estimated that labor costs would be around 60 dollars.

ACKNOWLEDGMENTS

Appreciation is extended to Dr. G. H. Larson, Head, Department of Agricultural Engineering, for his cooperation, guidance, and assistance in this investigation. Acknowledgment is also made to G. E. Fairbanks, Associate Professor, Department of Agricultural Engineering, and to Mrs. C. K. Reece, Miss Sandra A. Wilson, and Mrs. Leonard J. McKenna for their help in preparing the manuscript.

REFERENCES

- (1) Blevins, F. Z. and H. J. Hansen.
Power requirements of forage harvester operation determined and analyzed. Agr. Engg., Jan., 1956, pp. 21-27.
- (2) Burrough, D. E.
Power and torque distribution in farm machine drive shafts. Agr. Engg., June, 1953, pp. 382-385.
- (3) How to Apply SR-4 Gages.
Baldwin Lima Hamilton Corporation, Bul. 279-B. 1951.
- (4) Jensen, James K.
Experimental stress analysis. Agr. Engg., Sept., 1954, pp. 625-630.
- (5)

The use of SR-4 strain gages in the development of farm implements. John Deere Waterloo Tractor Works of Deere Manufacturing Co. 1950.
- (6) Lee, G. H.
An introduction to experimental stress analysis. New York: John Wiley and Sons. 1950.
- (7) Perry, C. C. and H. R. Lissner.
Strain gage primer. New York: McGraw-Hill Book Company, Inc. 1955.
- (8) Ruge, A. C., Dr. J. H. Meier, and C. H. Gibbons.
Equipment for separately measuring power in the cylinder shaft, threshing machinery, and sickle bar components of combine harvesters. Paper for presentation at the SAE National Tractor Meeting. 1946.
- (9) Schoenleber, L. H.
Farm machinery rapidly expanding use of strain gages and stress-coat. Agr. Engg., May, 1955, pp. 309-318.
- (10)

Use of strain gages and stress-coat for agricultural machinery design. Paper for presentation at the winter meeting of the American Soc. of Agr. Engg. 1954.
- (11) Senior, D. A.
Recording signals from resistance strain gages. Engineer, March 19, 1954, 197:410-413; March 16, 1954, 197:446-499; April 2, 1954, 197:482-483.

- (12) SR-4 Strain Gages, Instruments and Accessories.
Baldwin Lima Hamilton Corporation domestic price list.
1955.
- (13) The SR-4 Torquemeter
Baldwin Lima Hamilton Corporation, Bul. 4308. 1954.
- (14) Tatnall, F. G.
Field testing techniques using bonded wire strain
gages. American Soc. for Testing Materials, Bul. 199,
July, 1954.

INVESTIGATION AND DESIGN OF A TORQUEMETER
USING SR-4 STRAIN GAGES

by

CARROLL KENT REECE

B. S., Kansas State College of
Agriculture and Applied Science, 1952

AN ABSTRACT OF
A THESIS

submitted in partial fulfillment of the
requirements for the degree

MASTER OF SCIENCE

Department of Agricultural Engineering

KANSAS STATE COLLEGE
OF AGRICULTURE AND APPLIED SCIENCE

1957

The measurement of torque in operating machines has been of interest to engineers for many years. Many devices have been devised for the measurement of torque.

It was the purpose of this study to design, build, and test a compact torquemeter for the measurement of torque in tractor PTO shafts, irrigation pump power shafts, and any other applications to which the torquemeter may be adapted.

The torque was measured by measuring the unit strain produced in a round shaft under a condition of pure torque. With the unit strain it is possible to calculate the shear stress to which the material in the shaft is subjected, and with the shear stress it is possible to calculate the torque which produced it.

The device used to measure strain was the SR-4 strain gage. The SR-4 strain gage is a small grid of fine wire which is cemented to and insulated from the test specimen. The wire used has the physical property of linear variation in resistance with change in length. When the test specimen is strained the wire which is cemented to it is strained an equal amount. With current passing through the wire it is possible to measure the change in resistance caused by the strain. With the change in resistance known, it is possible to calculate unit strain.

It is known that a shaft subjected to pure torque suffers a stress condition of pure shear. It can also be shown from Mohr's Circle for stress that tension and compression stresses act at an angle of 45 degrees from the direction of the shear stress. From this discussion it can be seen that the strain gages were mounted at 45 degrees to the axis of the shaft. The gages were

also arranged so that the effects attributed to bending moments and axial loads on the shaft were canceled.

A slip ring and brush arrangement was designed to transfer the signal from the rotating shaft to the stationary recording instrument. Silver graphite brushes working on silver rings were used.

The torquemeter was tested by applying a static load with the shaft stationary. Within the operating range of the torquemeter the percentage of error was not greater than 5 per cent. The torquemeter was tested over a range of 300 to 6,000 inch-pounds of torque. The lower limit of the torquemeter range was found to be approximately 800 inch-pounds if the results are to be accurate. The torque may reach 15,000 inch-pounds without danger of damage to the torquemeter occurring.

The torquemeter results were also compared to torque values obtained from a hydraulic dynamometer, and were found to be in close agreement.

After the torquemeter was built and tested, a new design was proposed which would correct many of the faults which were found to be present in the original successful design.