

STRESS EVALUATION AND DESIGN METHODOLOGY
FOR PRODUCTS WITH PROTECTIVE COATINGS

by

BARTON CRAIG THOMPSON

B.S., Kansas State University, 1985

A MASTER'S THESIS

submitted in partial fulfillment of the
requirements for the degree

MASTER OF SCIENCE

College of Engineering

KANSAS STATE UNIVERSITY
Manhattan, Kansas

1987

Approved by:

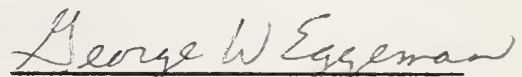
Major Professor

11207 310423

Copyright

STRESS EVALUATION AND DESIGN METHODOLOGY
FOR PRODUCTS WITH PROTECTIVE COATINGS

B. Craig Thompson

April, 1987

ACKNOWLEDGEMENTS

It is the wish of this investigator to extend his deepest gratitude to Dr. George Eggeman, Dr. Daniel Swenson, and Dr. Harry Knostman for their guidance and participation in the course of this study. Also, my deepest appreciation is expressed to the Department of Civil Engineering for providing test equipment and to Gary Thornton for providing the close tolerances of the test grips. Additional thanks go to Steve Coulson and the staff of the Engineering Computer Center for their help as well as use of the computer facilities. Finally, appreciation is expressed to the Department of Mechanical Engineering for financial support of a portion of this study.

TABLE OF CONTENTS

Chapter	Page
I. INTRODUCTION	1
Purpose of Research	1
II. LITERATURE REVIEW	4
Introduction	4
Graphite Failure Theories	5
Uniaxial Investigations	7
Coating Uses and Processes	8
Coating Failure Theories	10
III. MATERIALS AND METHODS	15
Materials Tested	15
Testing Methods	17
IV. RESULTS AND DISCUSSION	21
Introduction	21
Evaluation of Tensile Tests of Graphite	22
Evaluation of Tensile Test of Coated Specimen	32
Evaluation of Material Properties In Coated Specimen	38
Finite Element Analysis	51
Finite Element Solutions For Coated Specimen With 0.008 Inch Coating	58
Finite Element Solutions For Coated Specimen With 0.016 Inch Coating	64
V. SUMMARY AND CONCLUSIONS	72
Summary	72
Conclusions	73
BIBLIOGRAPHY	75
APPENDIX	
ABSTRACT	
VITA	

CHAPTER I

INTRODUCTION

Purpose of Research

Coated products have proven to be a solution to a wide variety of industrial problems. A product may be coated to improve appearance, to protect the product from abrasion, radiation, thermal shocks, or other factors. In the last 15 years, there has been a large amount of investigation into the electrical, thermal and resilience properties of coatings. The physical (elastic property) effects of coating a product, however, have gone largely unnoticed.

Many complications arise when designing a coated product. Often the exact material properties are not known. Without good material properties, mathematical characterization for the combined materials becomes futile. One problem in determining the material properties of a coating arises because the traditional

approach requires that a free film of the material be tested. Because of the application techniques, many coatings do not exist as a free film. Therefore, a method for determining the material properties of a coating on a substrate of known material properties needs to be developed.

A major need for accurate material properties is in the application of numerical design methods such as finite elements. The major trend in design and analysis in all disciplines of engineering is the finite element computer program. These programs require accurate material properties to reasonably predict the results.

Another complication in coated product design is the apparent strengthening or weakening of the substrate. In many cases a coated part will fracture at a lower load than will an uncoated product. In other cases, the product will support a substantially larger load with the coating than without. This creates a need for the development of an experimental technique to determine failure of the product. There

are no such methods available.

The objective of this investigation is to develop a design methodology for coated products in a uniaxial loading field. The proposed methodology development begins with a determination of the material properties of the core material. It uses these material values and an approach for separation of the stresses found in the composite material to determine the material properties of the second component material. A discussion is made to address the prediction of the failure of the coated product based upon the stress levels in each material.

The results of the proposed methodology are verified against experimental results under uniaxial tensile loading. In this investigation, a graphite core material and a chemical vapor deposited silicon carbide coating were chosen. The results are useful in determining premature failure as well as preventing over-design.

CHAPTER II

LITERATURE REVIEW

Introduction

Coating technology has been a rapidly growing facet of industry over the last two decades. With the advent of ceramic coatings, product protection has entered a new dimension. Several theories have been developed to predict coating performance. Still, the emphasis has been on "natural" causes of failure such as radiation, abrasion, and thermal deterioration. Very few theories pertain to the failure of the product due to an applied load.

This review is concerned with the theories, test procedures, and results of coated product failure. Of interest to this topic are the methods of testing and evaluating ceramic coatings and brittle materials used as substrates.

The emphasis of the investigation is placed on graphite as a core material and silicon carbide as the coating material. The graphite is chosen because it has reasonable well known material properties and a nearly constant Young's Modulus of Elasticity to failure. Silicon carbide is emerging as a leading coating, and was chosen for the tests.

Graphite Failure Theories

The lack of material properties has been a major problem in design. In 1960 at the Oak Ridge National Laboratory, the study on the continuum aspects of graphite originated. In 1970 Rowley [14] emphasized at The Conference on Continuum Aspects of Graphite Design that a model for the inelastic effects of graphite did not exist yet. In 1980 Hu, Swartz, and Huang [8] state that, with the trend toward finite element computer approximations, the lack of accurate material description for para-isotropic materials represents the major problem in solid mechanics. This illustrates that a continuing need for failure theories has existed for some time.

All of the failure theories found in current literature can be expressed as a function of the stresses applied to the part. The constants used in the failure theory functions are evaluated experimentally through simple fracture tests. Controversy still exists over the standards for these tests. Tang [17] presents an excellent review of failure theories for graphite. He divided the failure theories into four basic groups: (1) the maximum stress (strain) theories, (2) the maximum shear stress theories, (3) the maximum strain energy theories, and (4) the maximum distortion theories. Other names commonly applied to these theories are Beltrami, Rankine, Tresca, and Von Mises theories. Many other variations and extensions of these theories exist such as Mohr's Theories and variations on the stress tensor theory by Tsi and Wu.

Uniaxial Investigations

No testing techniques which provide a uniform stress state to failure for a uniaxial test specimen have gained universal acceptance. Both the ASTM and the British Standard have recommended uniaxial test and failure standards. Several methods exist for the testing of ductile materials, but their application to brittle materials is limited. Variations in test techniques can cause larger variations in the apparent strength of brittle materials than in ductile specimens.

Sedlacek [15] employed a tensile testing method for brittle materials which has been implemented by many investigators. In his method a ring of the specimen material is sealed between flat end plates and an internal pressure is applied. A major disadvantage of this method is that it cannot be used to find the material properties in a particular direction. Swartz [16] demonstrated a method in which a tensile sample is bonded between end platens. His method provided the accuracy of the standard

compression tests. The ASTM method employs an applied load beneath a lip in a tensile sample and a swivel and chain method to ensure alignment.

Material flaws in brittle fractures cause size effects to be a major concern. The cross sectional area of graphite fibers were reported by Jayatilaka [9] to be small enough to minimize the possibility of a flaw sufficiently dramatic to create a crack.

Uniaxial investigations for graphite employ many geometries and loading methods. Greenstreet et al. [5] investigated uniaxial properties, cyclic loadings, heterostatic loadings, and size effects. They concluded that within the selected range (0.128" to 0.625" diameter) size effects were negligible.

Coating Uses and Processes

Industrial coatings serve a wide range of purposes. Often they are used simply to make a product more attractive. More frequently, they are used to protect a part from environmental hazards such

as corrosives, abrasives, heat, or ultraviolet rays, cites Hill [6].

With such a variety of uses, many different coatings and application techniques have emerged. The most common application method is a plating method. This would be the emersion of the part in a liquified vat of the coating material then allowing it to cure. Other common techniques include electroplating, sputtering, thermal spraying, and chemical vapor deposition (CVD).

Silicon carbide must be deposited onto a substrate by the CVD method. Vigue [19] describes CVD as the use of a chemical reaction of gaseous compounds in contact with a heated substrate. The deposition continues as long as the process produces a solid. Two temperature plateaus must be maintained. The first is just below the evaporation temperature, ensuring constant vapor pressure of the source material. The second temperature is higher, allowing for the reaction. The vapor is carried from the evaporation zone to the reaction zone by a carrier

gas, see Figure 1. A reactant gas such as hydrogen or oxygen may be added to ensure metal or oxide deposition. For silicon carbide chemical vapor deposition, the reaction temperature is approximately 2300 degrees Fahrenheit.

Coating Failure Theories

Munger [11,12,13] separates protective coating failures into three categories: (1) coating formulation and selection, (2) substrate material and condition, and (3) coating application procedures. Coating formulation and selection failures occur when the product is exposed to an external condition beyond that of the design. Substrate material and condition failures occur when the substrate is not properly prepared for coating by removing any corrosion, drying, or removing chemical contents. Coating application failures include application to surface irregularities such as sharp corners, voids and cracks as well as general application (spraying) errors.

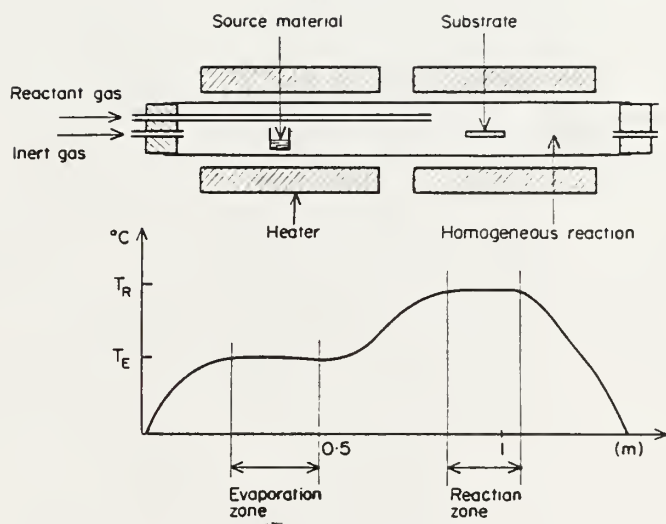

Figure 1 Basic CVD operation.

Silicon carbide as a coating on a graphite substrate is used primarily in electronic and radiation applications. Therefore, a fairly good base of data exists for the electrical and thermal properties of silicon carbide. Trester, et al. [18] provide data for thermal shock resistance of tiles coated with silicon carbide.

In many cases, the physical properties of coatings are difficult to determine because they must be studied as a film on the substrate. Unfortunately, the determination of material properties is best done on a free film. By nature, a CVD silicon carbide cannot exist as a free film. To date, there has been no standardization of test procedure, and often repeatability poses a problem. However, Hill [6] determined that coatings are generally viscoelastic. Avilxin [1] proposed a method in which a uniform stress is applied to the surface of the coated product. His method entails several complex mathematical calculations, but gives some useful results. Kuoinov [10] believes that many of the coating failures are due to a break in the bond

between coating and substrate. He proposes that the strength of adhesion is a function of the time of impact, the pressure generated during impact, and the particle/substrate temperature. He notes that the temperature is the only easily adjustable parameter. Another method, proposed by Bascom [2], also cites the adhesion of the coating as the critical parameter. He uses the coating as a adhesive to bond two parts together and determines the stress required to fail the bond, see Figure 2. In Bascom's test, two plates machined from the core material are bonded together by the coating. The bond is then broken by a cantilever loading and the ultimate stress to fail the bond is determined.

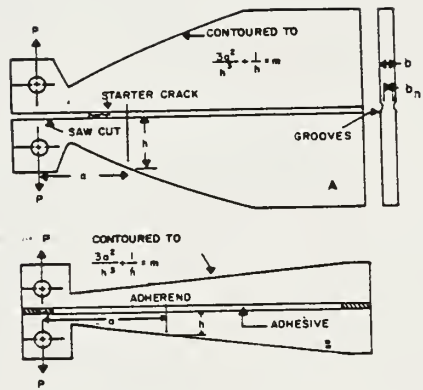

Figure 2 - Double cantilever beam fracture specimens tapered for constant compliance. A, bulk resin specimen; B, adhesive specimen.

CHAPTER III

MATERIALS AND METHODS

Materials Tested

The substrate material available for this investigation was a nuclear-grade graphite. The test specimens were an Ultra Carbon Corporation catalog number 999996-00 graphite machined by the Ultra Carbon Corporation to meet the ASTM standards for tensile testing of brittle materials shown in the appendix. The tapered center section causes a reduced area and helps facilitate fracture at the gage section. The graphite was produced using a new heated pressing method yielding a billet considered to have isotropic mechanical properties; that is, the properties in all directions are equivalent. Most graphite is extruded and exhibits transversely isotropic properties; that is, the properties along the extruded axis (the parallel direction) differ from those in the plane perpendicular to the extruded axis (the transverse

direction.) The manufacturer reported Young's Modulus of Elasticity (E) for the graphite as $1.2E6$ psi, and the coefficient of thermal expansion as $4.2E-6$ cm/°C ($3.0E-6$ in/°F).

Silicon Carbide (SiC) was chosen for the protective coating. Two sets of graphite test specimens were coated in thicknesses of 0.008 inches and 0.016 inches with Ultra Carbon Corporation's PT-444 Silicon Carbide Coating. Silicon carbide was chosen because of its hardness and resilience to abrasion.

The coating was applied by chemical vapor deposition (CVD.) A large variation in published material data exists. Young's Modulus was reported to range from $30E6$ psi to $65E6$ psi depending upon the purity and crystal structure of the chosen silicon carbide according to Driscoll [4]. He also gave a range for the coefficient of thermal expansion of $4.2E-6$ cm/°C ($3.0E-6$ in/°F) to $4.5E-6$ cm/°C ($3.2E-6$ in/°F). No published value of Poisson's ratio for Silicon carbide could be found.

Testing Methods

Uniaxial tensile tests were performed using the uncoated graphite specimen complying with the ASTM proposed standards for the tensile testing of brittle materials. The tapered shape helps increase the probability of fracture at the gage section, and the diameter is large enough so that size effects were negligible. The load was applied by the use of a 20,000 pound Riehle test machine. The load was then transferred to the grips (machined from aluminum to meet ASTM standards) by a polished chain, see Figure 3. This method distributes the load evenly under the lip of the sample. The chain ensures alignment of the load with the material axis, negating any bending moments which might be produced by the loading source.

The load was applied slowly and recorded at 25 pound increments along with the corresponding strains. Strain readings were obtained by using two Micro-Measurements EA-06-06ORZ-120 three element strain gage rosettes with a gage length of 1/16 inch.

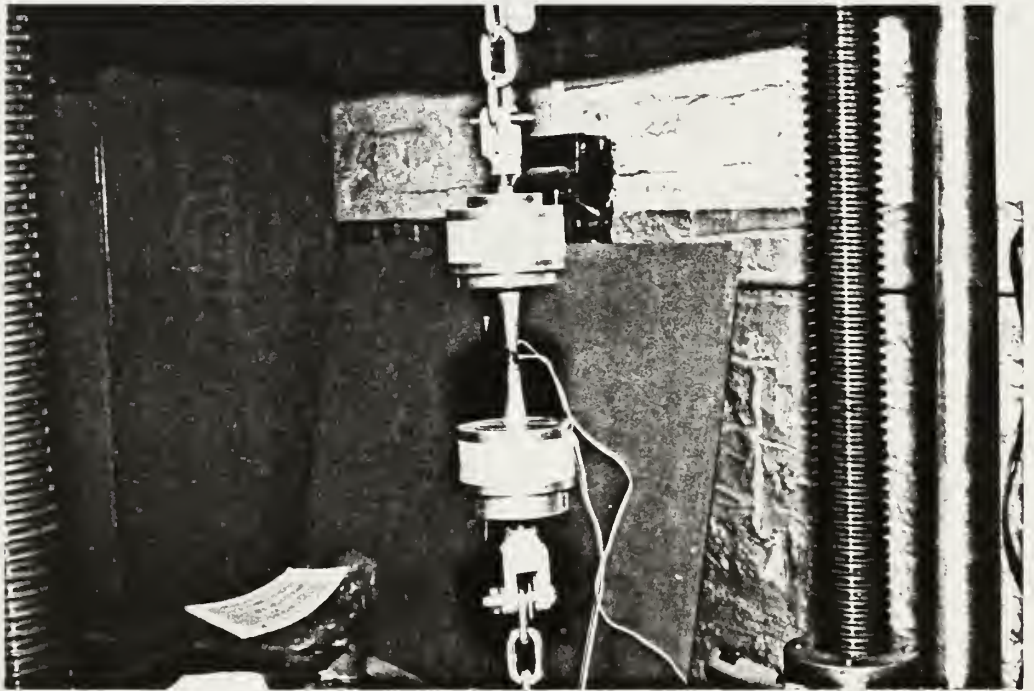
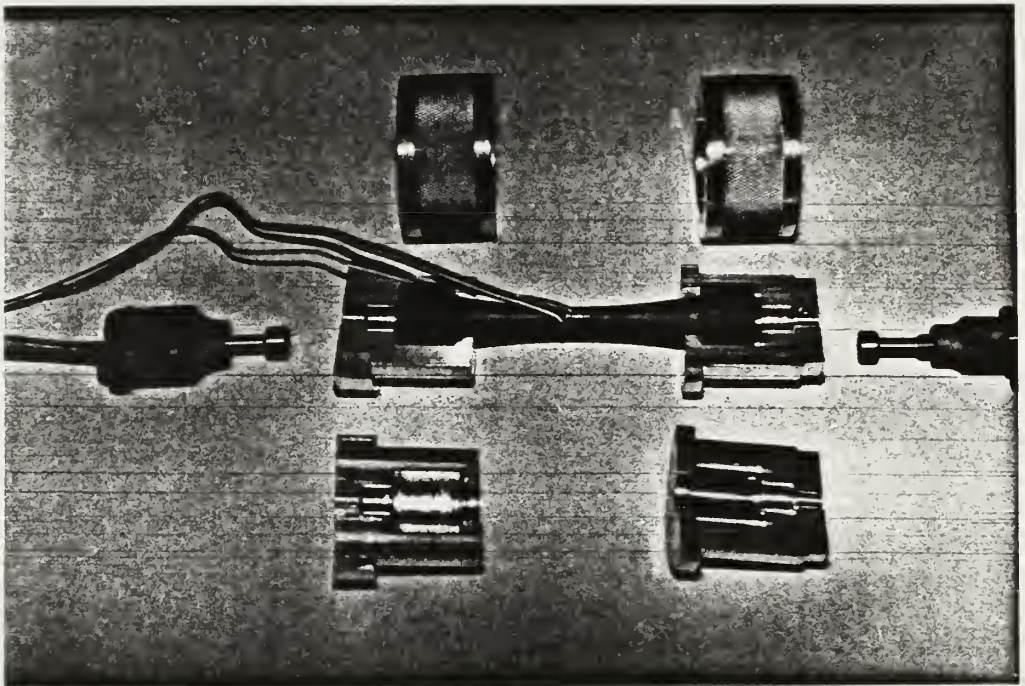

FIGURE:3: ASTM Tensile Test Procedure for Brittle Materials

The two gages were mounted in diametric opposition at the center (minimum area) section using M-Bond 200 Strain Gage Adhesive. The readings were measured using a Vishay Instruments SB-1 Switch and Balance Unit and a Vishay Instruments P-350A Digital Strain Indicator.

Failure of the strain gage, presumed to be a failure of the bond, was characterized by an abrupt drop in the strain readings followed by a continuous drop in the readings. Readings from these gages were used to the point of discontinuity, then ignored. Failure of the sample resulted in fracturing the specimen and not the adhesive bond.

The same procedures were followed for the graphite samples coated with the silicon carbide. There was a noticeable difference in the coating thickness from one side to the other of the coated parts as supplied. The gages were therefore mounted in opposition at the center (minimum area) section with one gage on the thicker coated area and the other gage on the side with the thinnest apparent coating. This trend was

followed for all samples of both the 0.008 inch and the 0.016 inch nominal coating thicknesses. The maximum and minimum diameters of the center sections as measured with a micrometer with a resolution of 0.0005 inches were recorded as a verification of coating thickness fluctuations. Such fluctuations in coating thickness are deemed inherent in CVD applications.

CHAPTER IV

RESULTS AND DISCUSSION

Introduction

In this chapter the results of the tests described in Chapter III are presented. In addition, results of finite element approximations using ANSYS - Engineering Analysis System by Swanson Analysis Systems, Incorporated are shown. Also included is a determination of the Young's Modulus of Elasticity and Poisson's ratio for the silicon carbide coating. These values are necessary to the setup of the finite element analysis.

The experimental results are presented first. Next, the theory for the determination of Young's Modulus of Elasticity and Poisson's ratio for the silicon carbide coating is presented. Then, the finite element solutions are provided. Finally, a comparison of the experimental and finite element

solutions is addressed.

Evaluation of Tensile Tests of Graphite

Principle strains, principle stresses, and gage orientations as well as incremental Young's Modulus of Elasticity and Poisson's ratio values for the graphite specimens are presented in the tables in this section. All of the graphite tensile specimens were of the tapered geometry prescribed by the ASTM proposed standards for the tensile testing of brittle materials. Some fractured tensile specimens are displayed in Figure 4.

Strain results of the tensile tests on the graphite tensile sample number 1 are shown in Table 1, page 25. The first column of Table 1 is the force applied by the Riehle test machine. The second column is the principle strain in the axial direction. The third column represents the principle strains in the transverse direction. The principle strains are calculated from the measured strains using the standard strain transformation equations:



FIGURE 4: Fractured Graphite Specimen

$$\epsilon_{1,2} = \frac{1}{2} \left\{ \epsilon_A + \epsilon_H \pm \left[(\epsilon_A - \epsilon_H)^2 + (2\epsilon_{45} - \epsilon_A - \epsilon_H)^2 \right]^{1/2} \right\}$$

where:

ϵ_1 = first principle strain

ϵ_2 = second principle

ϵ_A = measured axial strain

ϵ_H = measured transverse (hoop) strain

ϵ_{45} = strain measured 45 deg from axial direction

The angle by which the principle strain directions differ from the axial strain gage direction is calculated as:

$$\phi = \frac{1}{2} \tan^{-1} \left[(2\epsilon_{45} - \epsilon_A - \epsilon_H) / (\epsilon_A - \epsilon_H) \right]$$

This angle was assumed to be the angle by which the gage direction differed from the axis of symmetry. This variation was attributed to error in the visual alignment of the gages in the bonding process. The final column of Table 1 is Poisson's ratio of the graphite as calculated by:

$$\nu = -\epsilon_H / \epsilon_A$$

GRAPHITE TENSILE TEST RESULTS
VALUES FOR UNCOATED SPECIMEN

Sample 1

Load (lbs)	Strain 1 (E-6 in/in)	Strain 2 (E-6 in/in)	Phi (deg)	Poisson (in/in)
70	1093	-90	0.1	0.08
100	1485	-123	0.1	0.08
125	1790	-146	0.3	0.08
150	2125	-170	0.5	0.08
175	2497	-192	0.6	0.08
200	2876	-213	0.8	0.07
225	3241	-234	1.0	0.07
250	3578	-256	1.1	0.07
275	3967	-280	1.2	0.07
300	4347	-296	1.4	0.07

Table 1: Graphite Strain Results

The strain results for samples 4, 5, and 6 are included in Table 1 in the appendix.

Stress results for the graphite sample number 1 corresponding to the loading and strain results are presented in Table 2. Results of the other samples appear in the appendix. The equations for the stress calculations are derived from the stress - strain relations for the standard 3 element, 45 degree strain gage rosette. They are:

$$\sigma_{1,2} = \frac{E}{2(1-\nu)} (\epsilon_A + \epsilon_H) \pm \frac{E}{(1+\nu)} e$$

where:

σ_1 = Stress in the axial direction

σ_2 = Stress in the transverse direction

E = P/(A*) is Young's Modulus of Elasticity

P = Applied Force

A = Cross Sectional Area

$$e = \frac{1}{2} [(\epsilon_A - \epsilon_H)^2 + (2\epsilon_{45} - \epsilon_A - \epsilon_H)^2]^{1/2}$$

GRAPHITE TENSILE TEST RESULTS
VALUES FOR UNCOATED SPECIMEN

Sample 1

Load (lbs)	Stress 1 (psi)	Stress 2 (psi)	E (E6 psi)
70	927	-0.00	0.85
100	1324	-0.01	0.89
125	1656	-0.05	0.93
150	1987	-0.17	0.94
175	2318	-0.34	0.93
200	2650	-0.57	0.92
225	2981	-0.93	0.92
250	3313	-1.33	0.92
275	3645	-1.69	0.92
300	3977	-2.29	0.91

Table 2: Graphite Stress Results

The first column of Table 2 is the load applied. The first principle stress is reported in the second column. The third column is the stress in the second principle direction. The final column is for Young's Modulus of Elasticity.

A Fortran computer routine which performs the calculations from this section was written and shown in Figure 5. Also a plot of the force (stress since a constant area is involved) versus strain is produced in Figure 6. Three samples and a straight line approximation to the data are plotted.

The critical values of the material properties for the graphite are presented in Table 3. The values of interest are: the ultimate tensile stress, the Young's Modulus of Elasticity, and Poisson's ratio. The calculated values of Young's Modulus of Elasticity agreed with the range provided by the manufacturer. The manufacturer's values are also included in Table 3 for comparison. This is an important aspect of the

```

REAL MU, MUSUM
WRITE(6,*) 'INPUT NO OF DATA PTS AND SAMPLE NO'
READ(5,*) N,L
MUSUM = 0
A = 3.14159/4**0.31**2
ESUM = 0
WRITE(9,*) 'FOR SAMPLE NO.', L
WRITE(9,*) 'EPS1          EPS2          PHI          SIG1          SIG2'
1
DO 10 I=1, N
  INPUT P, EA, E45, EH
  WRITE(6,*) P, EA, E4, EH
  READ(5,*) P, EA, E4, EH
  E1 = 0.5*(EA+EH) + ((EA-EH)**2 + (2**E4-EA-EH)**2)**0.5
  E2 = 0.5*(EA+EH) - ((EA-EH)**2 + (2**E4-EA-EH)**2)**0.5
  PHI = ATAN((2**E4-EA-EH)/(EA-EH))
  EPS/A/EA
  ESUM = ESUM + E
  MU = -EH/EA
  MUSUM = MUSUM + MU
  T1 = (EA+EH)/2
  T2 = ((EA-EH)**2 + (2**E4-EA-EH)**2)**0.5/2
  SIG1 = (T1/(1-MU) + T2/(1+MU))*E
  SIG2 = (T1/(1-MU) - T2/(1+MU))*E
10
WRITE(9,*) E1, E2, PHI, SIG1, SIG2, E, MU
WRITE(9,*) 'YOUNGS MODULUS = ', ESUM/N
WRITE(9,*) 'POISSONS RATIO = ', MUSUM/N
STOP
END

```

FIGURE 5: Fortran Routine To Calculate Principle Stresses And Strains From Three Element Gauge Data

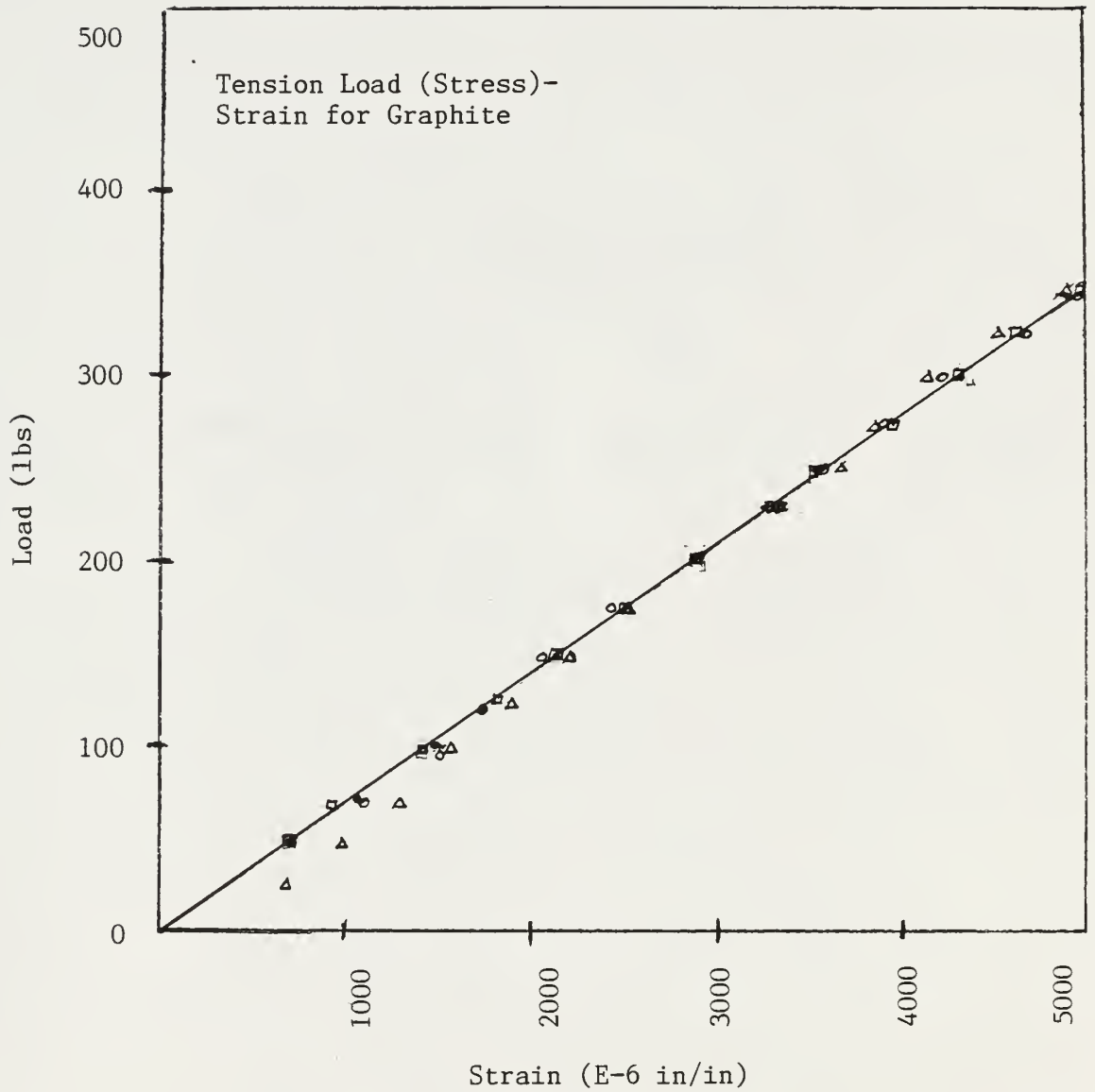

FIGURE 6: Uniaxial Tensile Load (Stress) - Strain for Graphite

GRAPHITE TENSILE TEST RESULTS
MATERIAL PROPERTIES FOR UNCOATED SPECIMEN

Sample No.	Stress (Max) (psi)	Young's Modulus (E6 psi)	Poisson's Ratio
1	3977	0.92	0.08
4	----	1.26	0.10
5	5705	0.95	0.07
6	4977	1.15	0.12
Avg.	4900	1.05	0.09
Mfg.		1.40	

Table 3: Graphite Material Property Results

work since it provided the manufacturer with backup data on a new type of graphite material.

Evaluation Of Tensile Test Of Coated Specimens

The same computer program that was run to evaluate the material properties of the graphite specimen in the preceding section was run to determine effective values of the coated specimen. The only change made in the program was a correction of the area to accommodate the coating thickness. The strain values and directions for sample number 1 of the 0.008 inch coating thickness from the program are given in Table 4. The strain results from samples 2 and 3 appear in the appendix. Because there was a variation in the thickness due to uneven application of the coating, the values of each side of a specimen are presented separately in the tables. Table 5 shows results of the stress evaluations on specimen number 1 with the 0.008 inch coating thickness as computed. The program operates on the assumption that the specimen exhibits constant material properties. A large difference in properties exists between graphite and silicon

GRAPHITE TENSILE TEST RESULTS
VALUES FOR SPECIMEN WITH 0.008 INCH COATING

Sample 1		Side 1		
Load (lbs)	Strain 1 (E-6 in/in)	Strain 2 (E-6 in/in)	Phi (deg)	Poisson (in/in)
25	156	-23	-13.4	0.09
50	300	-45	-13.4	0.10
75	417	-65	-13.4	0.10
100	546	-83	-13.7	0.09
125	673	-106	-14.2	0.09
150	1195	-170	-17.9	0.09
175	1438	-224	-18.0	0.07
200	1466	-136	-12.6	0.04
225	1656	-149	-12.5	0.04
250	2396	-256	-15.0	0.03
275	2505	-231	-13.0	0.04

Sample 1		Side 2		
Load (lbs)	Strain 1 (E-6 in/in)	Strain 2 (E-6 in/in)	Phi (deg)	Poisson (in/in)
25	109	-16	- 3.4	0.15
50	219	-37	- 2.6	0.16
75	336	-56	- 2.2	0.17
100	473	-75	- 1.8	0.16
125	597	-100	- 0.7	0.17
150	797	-142	- 2.3	0.18
175	1004	-184	- 0.5	0.18
200	1471	-211	- 1.2	0.14
225	1848	-270	- 2.7	0.12
250	2103	-270	- 1.8	0.13
275	2385	-269	- 1.1	0.11

Table 4: Coated Product Effective Strain

GRAPHITE TENSILE TEST RESULTS
 VALUES FOR SPECIMEN WITH 0.008 INCH COATING

Sample 1 Side 1

Load (lbs)	Stress 1 (psi)	Stress 2 (psi)	E (E6 psi)
25	311	-17	2.00
50	623	-35	2.16
75	935	-53	2.25
100	1250	-74	2.30
125	1572	-101	2.35
150	1969	-205	1.65
175	2303	-244	1.61
200	2476	-124	1.69
225	2784	-137	1.68
250	3166	-226	1.32
275	3417	-183	1.37

Sample 1 Side 2

Load (lbs)	Stress 1 (psi)	Stress 2 (psi)	E (E6 psi)
25	295	-1	2.70
50	589	-1	2.68
75	883	-1	2.63
100	1177	-1	2.49
125	1470	-0	2.46
150	1767	-3	2.22
175	2058	-0	2.05
200	2353	-1	1.60
225	2652	-6	1.44
250	2943	-3	1.40
275	3236	-1	1.36

Table 5: Coated Product Effective Stress

carbide. Therefore, the stress is an average or effective value of the cross section and has little physical meaning. However, it does indicate a nonlinearity in the apparant Young's Modulus of Elasticity suggesting some type of stress concentration.

Table 6 contains the strain evaluations for specimen number 1 with the 0.016 inch coating thickness. Again this was done with the computer program presented in the previous section with a correction in the area to accommodate the coating thickness. The effective (constant material property approximation) stress evaluations for the 0.016 inch coating thickness specimen number 1 is exhibited in Table 7. The strain and stress results of additional samples appear in the appendix. As with the 0.008 inch coating thickness evaluations, the variations in coating thickness caused a sufficient spread in the data to necessitate presentation of each side individually.

GRAPHITE TENSILE TEST RESULTS

VALUES FOR SPECIMEN WITH 0.016 INCH COATING

		Sample 1	Side 1		
Load (lbs)	Strain 1 (E-6 in/in)	Strain 2 (E-6 in/in)	Phi (deg)	Poisson (in/in)	
25	12	- 2	- 4.1	0.17	
50	25	- 3	- 4.1	0.12	
75	43	- 5	- 6.1	0.10	
100	57	- 6	- 6.8	0.09	
125	73	- 8	- 7.0	0.10	
150	89	- 9	- 7.2	0.10	
175	104	-12	- 7.1	0.10	
200	124	-14	- 7.1	0.10	
225	143	-16	- 7.1	0.10	
250	161	-19	- 7.0	0.10	
275	181	-20	- 7.0	0.10	
300	201	-23	- 7.3	0.10	
325	220	-25	- 7.3	0.10	
350	241	-28	- 7.0	0.10	
375	269	-31	- 7.3	0.10	

		Sample 1	Side 2		
Load (lbs)	Strain 1 (E-6 in/in)	Strain 2 (E-6 in/in)	Phi (deg)	Poisson (in/in)	
25	34	- 4	- 3.0	0.12	
50	71	- 9	- 2.1	0.13	
75	113	-14	- 1.1	0.12	
100	151	-18	- 1.2	0.12	
125	189	-22	- 1.0	0.12	
150	226	-27	- 1.0	0.12	
175	260	-31	- 1.0	0.12	
200	296	-35	- 1.0	0.12	
225	333	-38	- 0.9	0.11	
250	365	-41	- 0.8	0.11	
275	398	-44	- 0.6	0.11	
300	429	-48	- 0.8	0.11	
325	462	-52	- 0.7	0.11	
350	494	-55	- 0.7	0.11	
375	-----	-----	-----	-----	

Table 6: Coated Product Effective Strain

GRAPHITE TENSILE TEST RESULTS
VALUES FOR SPECIMEN WITH 0.016 INCH COATING

Sample 1 Side 1			
Load (lbs)	Stress 1 (psi)	Stress 2 (psi)	E (E6 psi)
25	275	- 1	22.8
50	550	- 3	21.9
75	830	-10	19.6
100	1107	-12	19.6
125	1388	-19	19.0
150	1667	-25	18.7
175	1947	-31	18.6
200	2224	-34	18.0
225	2535	-39	17.7
250	2778	-41	17.2
275	3057	-47	16.9
300	3339	-54	16.7
325	3618	-59	16.4
350	3890	-59	16.2
375	4175	-69	15.6

Sample 1 Side 2			
Load (lbs)	Stress 1 (psi)	Stress 2 (psi)	E (E6 psi)
25	274	-1	8.1
50	548	-1	7.7
75	821	-0	7.3
100	1095	-0	7.3
125	1369	-1	7.2
150	1642	-1	7.3
175	1916	-1	7.4
200	2190	-1	7.4
225	2497	-1	7.5
250	2738	-1	7.5
275	3011	-0	7.6
300	3285	-1	7.7
325	3559	-1	7.7
350	3833	-1	7.7
375	-----	-----	-----

Table 7: Coated Product Effective Stress

The effective material properties for all of the coated specimen are presented in Table 8. Of interest here is the ultimate load (stress) variations. With no coating the specimen supported 375 pounds. The 0.008 and 0.016 inch coating specimen supported 275 and 475 pounds respectively. Again, these values represent the given strain field with the assumption that material properties are constant throughout the specimen. The force (stress) versus strain data for the specimen with the 0.008 inch coating is plotted in Figure 7. The plot for the 0.016 inch coated specimen is Figure 8. In these plots, each point symbol represents a different sample, and the solid line is an approximate fit to the data points.

Evaluation Of Material Properties In Coated Specimen

This section deals with a method for the separation of the stresses in the graphite substrate from those in the silicon carbide coating. The material properties of the core material were determined in the Evaluation of Tensile Tests of Graphite section. The calculated values of the

GRAPHITE TENSILE TEST RESULTS
MATERIAL PROPERTIES FOR COATED SPECIMEN

0.008 INCH COATING

Sample No.	Side No.	Stress (Max) (psi)	Young's Modulus (E6 psi)	Poisson's Ratio
1	1	3378	1.85	0.07
1	2	3378	2.00	0.15
2	1	3174	2.13	0.13
2	2	3174	2.55	0.19
3	1	2696	1.55	0.14
3	2	2696	1.85	0.07
Avg.		3100	1.99	0.13

0.016 INCH COATING

Sample No.	Side No.	Stress (Max) (psi)	Young's Modulus (E6 psi)	Poisson's Ratio
1	1	4082	18.31	0.10
1	2	4082	7.52	0.12
2	1	4463	12.33	0.10
2	2	4463	10.25	0.11
3	1	5192	14.34	0.16
3	2	5192	9.15	0.10
Avg.		4579	11.98	0.11

Table 8: Coated Product Material Property Results

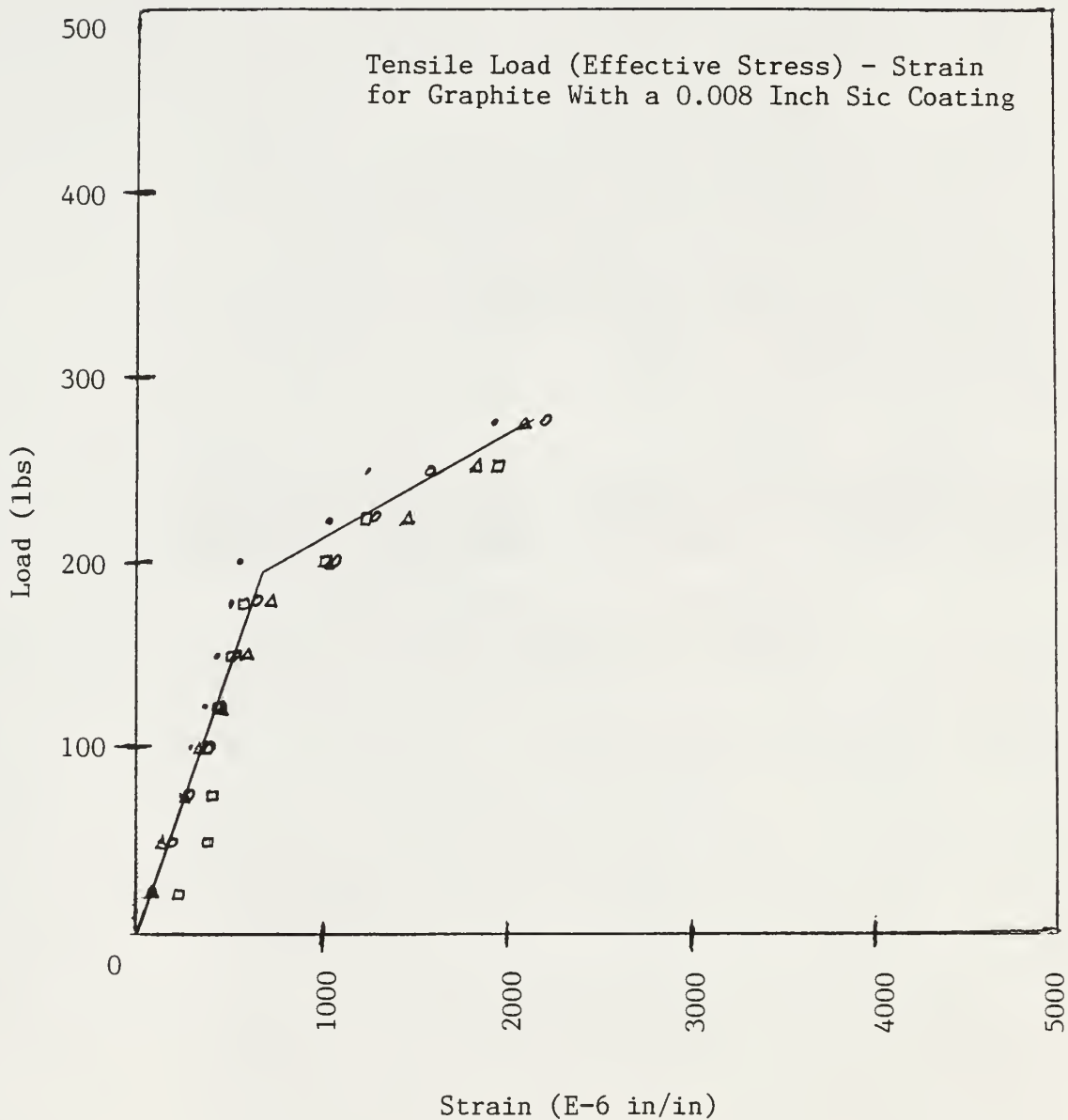

FIGURE 7: Uniaxial Tensile Load (Effective Stress) - Strain for Graphite With a 0.008 Inch SiC Coating

Note: Scale is same as used in FIGURE 6 for comparison.

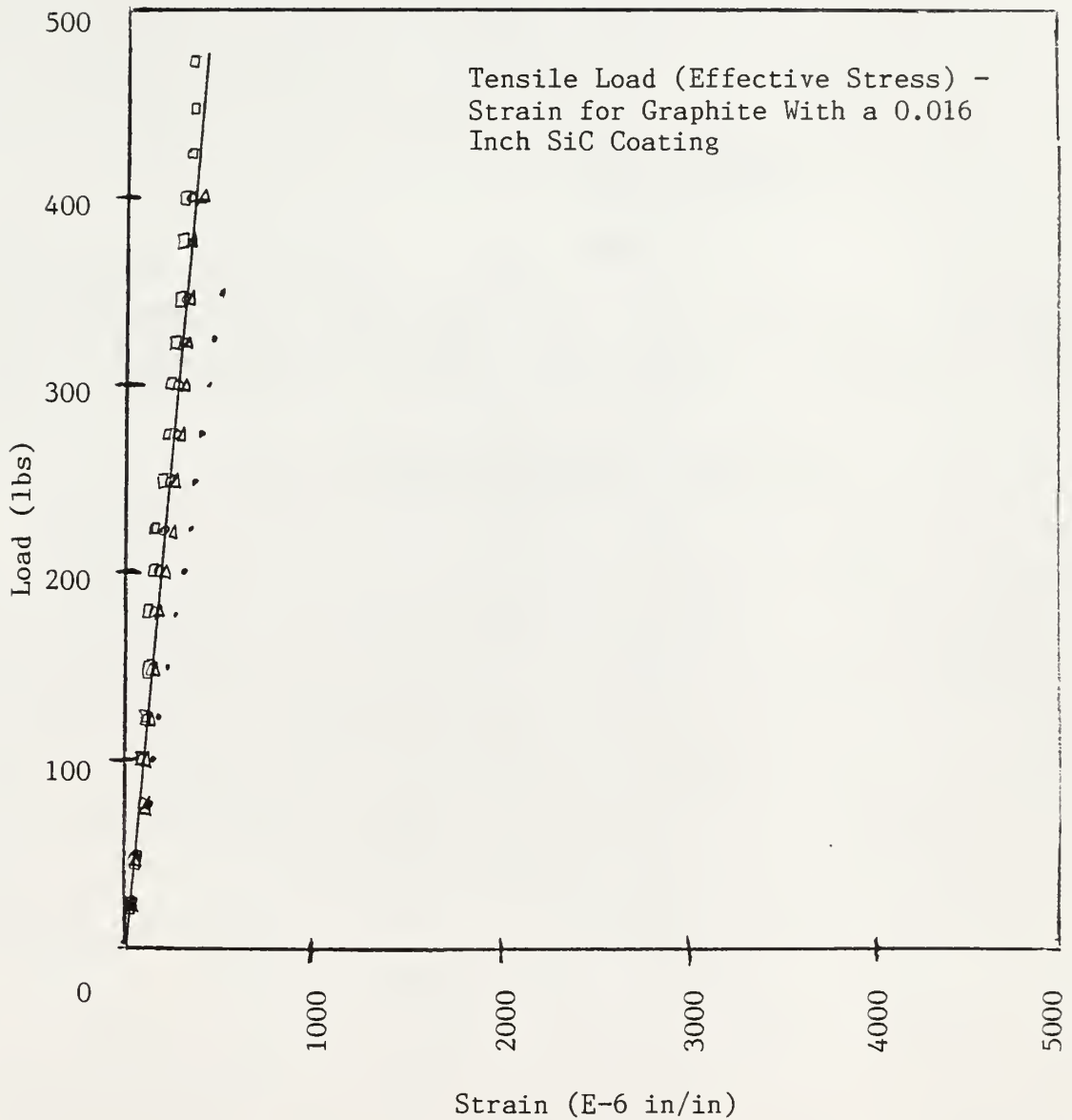

FIGURE 8: Tensile Load (Effective Stress) - Strain for Graphite With a 0.016 Inch SiC Coating

NOTE: Scale is same as used in FIGURE 6 for comparison

graphite substrate material properties will be used in the separation of the stresses.

The key to the approach for the separation of the stresses in the substrate from those in the coating is the assumption that the strain (elongation) is constant throughout the cross section. Admittedly, this assumption cannot be rigidly proved, but with the small cross sectional area, small deflections, uniform load, and consideration that the coating cannot slip on the substrate, the assumption seems to be a reasonable approximation. The graphite and silicon carbide share a common surface, and it is assumed that there is no slippage in the bond. Therefore, at the common surface the two materials have the same strain.

Once the assumption that the strain is constant throughout the cross section is accepted, the silicon carbide coating is treated as a thin wall cylinder force fit onto the solid graphite cylinder. The equations for the thin wall cylinder are:

$$\epsilon_{\theta} = \frac{-\sigma_{zs} \nu_s}{E_s} + \frac{\sigma_r R}{E_s t}$$

$$\epsilon_z = \frac{\sigma_{zs}}{E_s} - \frac{\sigma_r R \nu_s}{E_s t}$$

The equations governing the solid graphite cylinder are:

$$\epsilon_{\theta} = \frac{-(1-\nu_g)}{E_g} \sigma_r - \frac{\nu_s}{E_g} \sigma_{zg}$$

$$\epsilon_z = \frac{2\nu_g}{E_g} \sigma_r + \frac{\sigma_{zg}}{E_g}$$

Finally the boundary condition requiring load equilibrium is:

$$P = \sigma_{zg} A_g + \sigma_{zs} A_s$$

where:

ϵ_{θ} = Strain Measured In The Hoop Direction

ϵ_z = Strain Measured In The Axial Direction

R = Radius Of Coating

t = Coating Thickness

P = Load Applied To Sample

σ_r = Radial Contact Stress Between Substrate
And Coating

σ_{zs} = Axial Stress In Silicon Carbide Coating

σ_{zg} = Axial Stress In Graphite Substrate

A_s = Cross Sectional Area Of Coating

A_g = Cross Sectional Area Of Substrate

E_s = Young's Modulus Of Coating

E_g = Young's Modulus Of Substrate

ν_s = Poisson' Ratio Of Coating

ν_g = Poisson's Ratio Of Substrate

These five equations reduce to the following sequence for solution of the material properties for the silicon carbide coating:

$$\sigma_r = - \frac{\nu_g E_z E_g + E_\theta E_g}{(1+\nu_g)(1-2\nu_g)}$$

$$\sigma_{zg} = E_z E_g - 2\nu_g \sigma_r$$

$$\sigma_{zs} = \frac{P - \sigma_{zg} A_g}{A_s}$$

$$\nu_s = \frac{\frac{\sigma_{zs}}{E_z} - \frac{\sigma_r R}{t E_\theta}}{\frac{\sigma_r R}{t E_z} - \frac{\sigma_{zs}}{E_\theta}}$$

$$E_s = \frac{\sigma_{zs}}{E_z} - \frac{\sigma_r R \nu_s}{t E_z}$$

Shown in Table 9 are the results for specimen number 1 with the 0.008 inch coating. The first column is the applied load, the second column gives the stress in the silicon carbide coating. The third reports the strain, and the last column gives Young's Modulus of Elasticity for the coating. The results for the other samples are in the appendix. Table 10 gives the same information for the 0.016 inch coating thickness.

COATED GRAPHITE TENSILE TEST RESULTS
VALUES FOR 0.008 INCH SILICON CARBIDE COATING

Sample 1 Side 1

Load (lbs)	Stress (psi)	E (E6 psi)	Poisson (in/in)
25	4578	30	0.12
50	9167	31	0.12
75	13836	33	0.14
100	18730	33	0.14
125	23477	33	0.14
150	29072	26	0.07
175	29599	25	0.14
200	25818	27	0.08
225	28144	27	0.09
250	29639	23	0.07
275	30154	24	0.08

Sample 1 Side 2

Load (lbs)	Stress (psi)	E (E6 psi)	Poisson (in/in)
25	4973	39	0.18
50	9766	39	0.17
75	14457	38	0.17
100	19159	37	0.16
125	23805	36	0.16
150	26111	34	0.13
175	27290	32	0.10
200	27713	27	0.08
225	27043	25	0.10
250	25896	25	0.06
275	26643	24	0.08

Table 9: 0.008 Inch Coating Test Results

COATED GRAPHITE TENSILE TEST RESULTS
VALUES FOR 0.016 INCH SILICON CARBIDE COATING

Sample 1 Side 1

Load (lbs)	Stress (psi)	E (E6 psi)	Poisson (in/in)
25	1367	62	0.16
50	2723	52	0.12
75	4057	51	0.11
100	5411	51	0.10
125	6761	49	0.11
150	8118	48	0.10
175	9489	48	0.11
200	10851	44	0.11
225	12207	41	0.11
250	13586	40	0.11
275	14961	38	0.11
300	16353	36	0.11
325	17699	35	0.11
350	19108	34	0.11
375	20374	30	0.11

Sample 1 Side 2

Load (lbs)	Stress (psi)	E (E6 psi)	Poisson (in/in)
25	1369	40	0.11
50	2724	38	0.12
75	4056	36	0.11
100	5407	36	0.11
125	6757	36	0.11
150	8112	36	0.11
175	9481	36	0.11
200	10842	36	0.11
225	12196	36	0.11
250	13575	37	0.11
275	14949	37	0.10
300	16331	38	0.11
325	17705	38	0.11
350	19084	38	0.11

Table 10: 0.016 Inch Coating Test Results

It is apparent that the calculations yield comparable values for Young's Modulus of Elasticity and Poisson's ratio for the silicon carbide coating regardless of the coating thickness. Figure 9 plots the stress in the coatings against the strain for each coating thickness. The plot further illustrates the agreement of Young's Modulus (the slope of the plots.)

The plot of the stress and strain of the coating raises an interesting question. The 0.008 inch coating has a change in Young's Modulus (slope) to a very small value. The explanation for such a change is a transition into a plastic region. The point at which the slope changes would be the yield point for the silicon carbide coating. The specimen with the 0.016 inch coating does not exhibit yielding in the strain data, but broke at the root near the grip area rather than the gage section. Examples of the failed parts are shown in Figure 10.

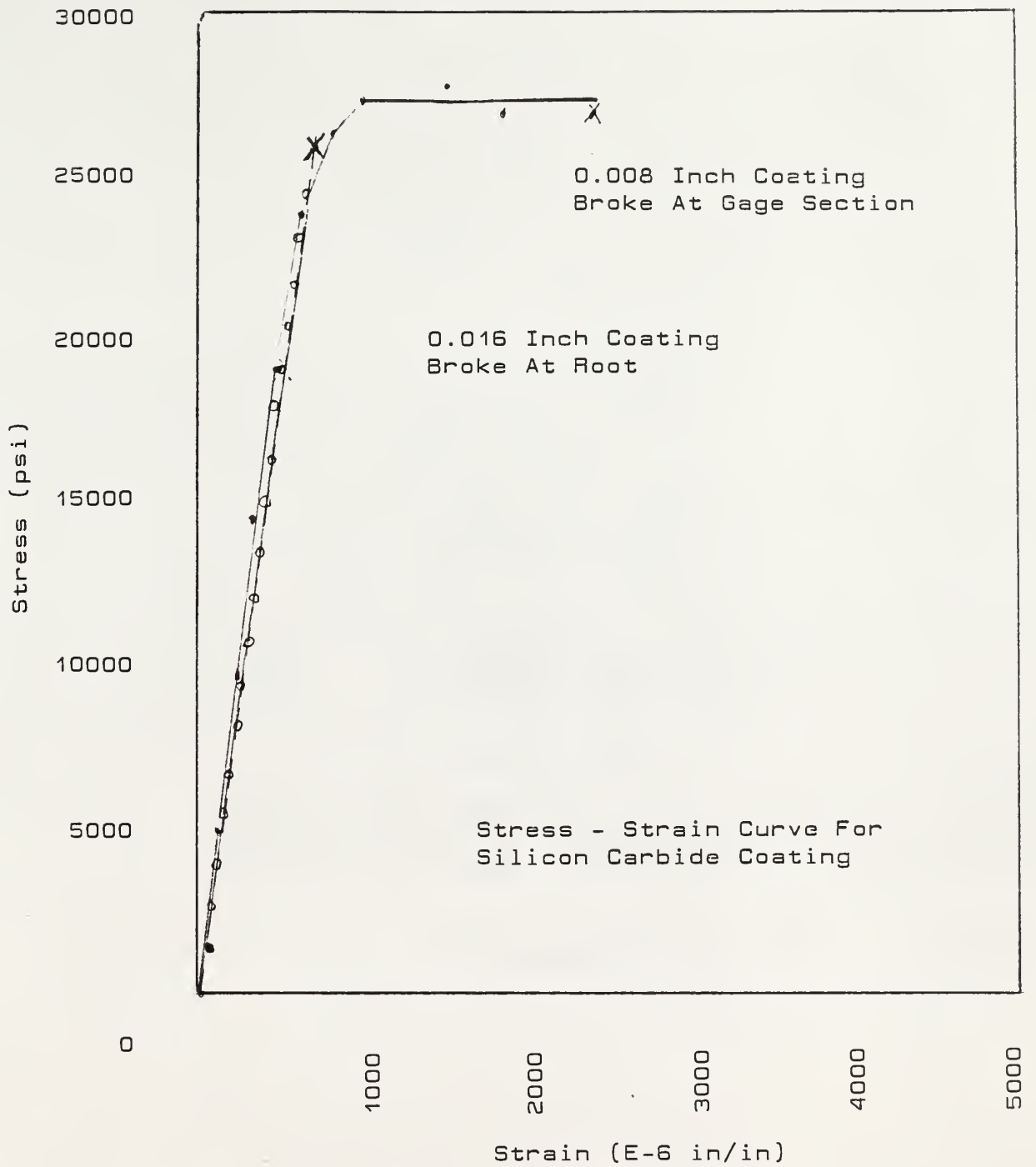

FIGURE 9: Stress - Strain for Silicon Carbide Coating



Fractured Specimen With a 0.003 Inch Coating



Fractured Specimen With a 0.016 Inch Coating

FIGURE 10: Coated Specimen After Fracture

The strain at fracture for the specimens with the 0.016 inch coating corresponds to that for the yield point for those with the 0.008 inch coating. The stresses at failure vary from one specimen to another, but fall into a limited range suggesting a maximum allowable stress value range of 26000 to 28000 psi. An average value for Young's Modulus of Elasticity for silicon carbide calculated by this method was $37E6$ psi. The specimens with the 0.016 inch coating all fractured at the root. This was probably due to a combination of stress concentration and shearing effects at an interior corner with thick coatings as researched by Munger [11].

Another observation for design criterion is that the specimens with the thin (0.008 inch) coating failed at a lower load than the uncoated specimens, while the thick (0.016 inch) coated specimens supported the largest load. All of the coated specimens followed a failure envelope dependant almost exclusively on the coating stress. The explanation for the lower load handling capabilities of the specimens with the thin coating is that when the

coating reaches it's ultimate stress it fractures causing the load to be suddenly shifted to the graphite substrate as an impact load (very high strain rate). This would suggest that when the ultimate stress of either the coating or the substrate is reached, the product suffers a catastrophic failure.

Finite Element Analysis

A major tool in researching a product's reactions to a stress field today is the finite element computer program. The typical finite element software package offers the choice of element shapes, loading patterns, and material properties. They are capable of calculating stress results due to a variety of loadings including thermal gradients and physical loadings. The largest hindrance is the need for accurate material properties.

A data file representing the graphite tensile test specimen was created for the ANSYS finite analysis program. The file generates the elements for the upper right quadrant of the ASTM tensile test specimen for brittle materials. The quadrant generation makes use of symmetry about the y-axis and the x-z plane to reduce the number of elements and more importantly the size of the coefficient matrix to be inverted in the program, and in turn, memory space and time. The element grid generated by the ANSYS program appears in Figure 11.

The data file places a pressure equivalent to tensile load under the lip of the specimen. This is the same location and loading pattern that was used in the experimental tests. The program assumes linear elastic material properties. Therefore, a line through the zero point and the point generated on any one run should represent runs at all loads. The program was run at 50 pound increment from 50 to 350 pounds to confirm this assumption. The material properties used in the program were those calculated in the experimental analysis of the graphite specimen.

ANSYS 4.2B
JAN 23 1987
10:06:54
POST1 ELEMENTS

ZU=1
DIST=1.37
XF=.25
YF=1.25

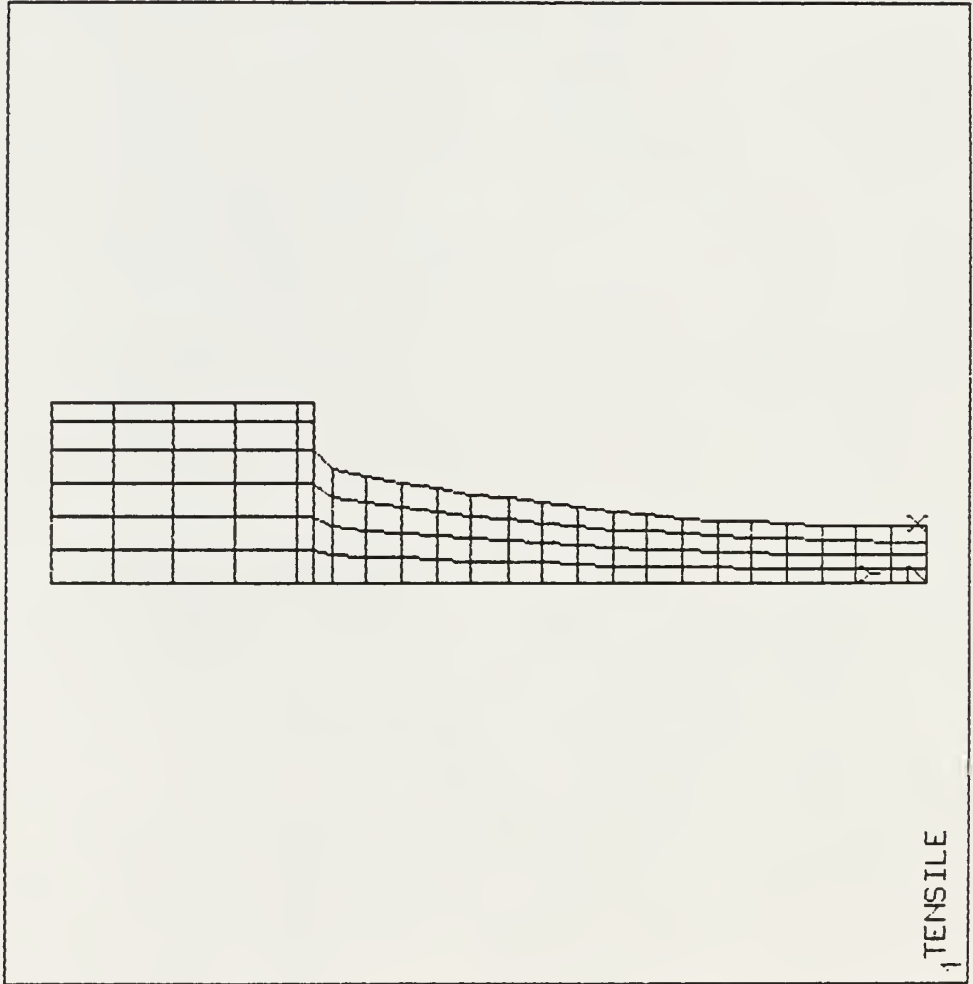

FIGURE 11: ANSYS Element Grid for Graphite Specimen

The Young's Modulus of Elasticity and Poisson's ratio were $1.0E6$ psi and 0.09 respectively.

The output of the ANSYS finite element program includes the displacements (used to calculate strains) and stresses at each node. Figure 12 is a plot of the displaced element grid for the graphite specimen. A summary table of the values at the area where the strain gage was applied for each of the loadings and the variation from the experimental values are presented in Table 11.

The stress distribution plot appears in Figure 13. The small darkest area located at the lip is in compression and is the point of loading. The area surrounding the compression area (area above the root) has essentially a zero stress. The stresses increase as you move toward the center (gage) section. The maximum was on the surface at the center section, as expected.

ANSYS 4.2B
JAN 23 1987
10:11:05
POST1 DISPL.
STEP=1
ITER=1
ZU=1
DIST=1.37
XF=.25
YF=1.25
DMAX=.00552
DSCA=24.9

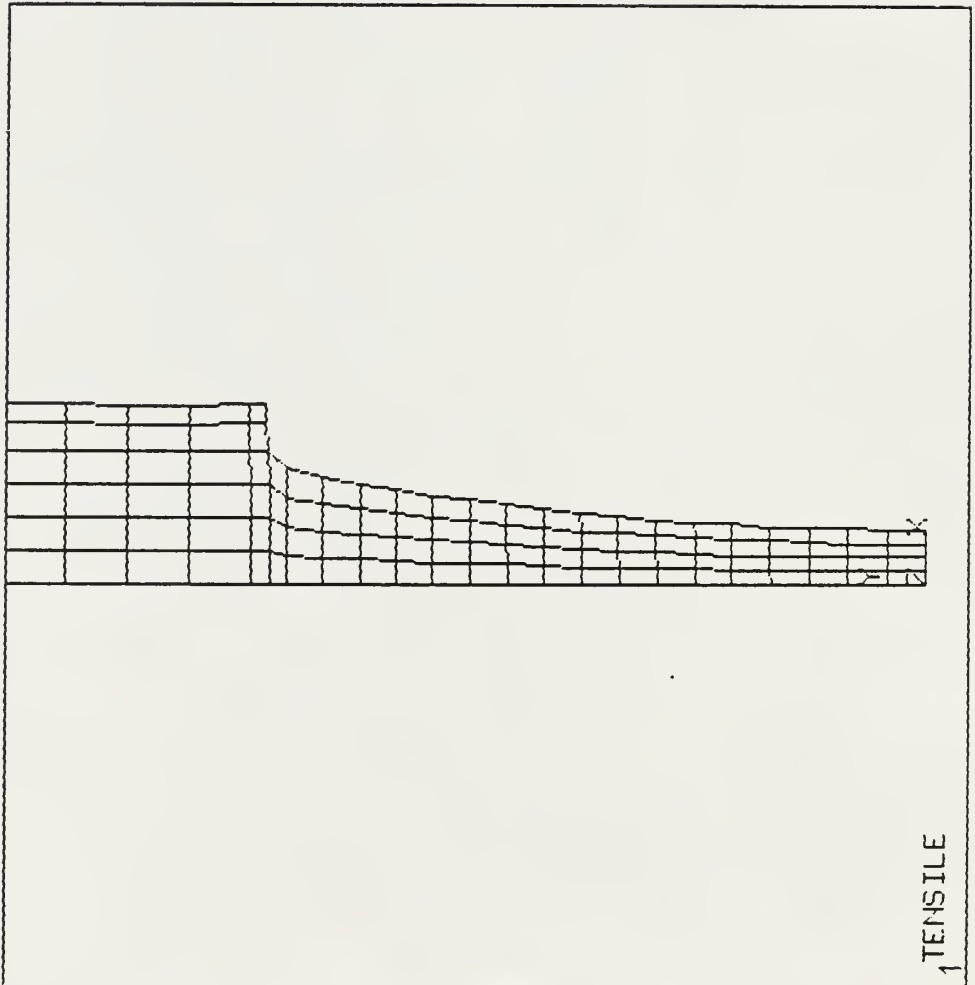

FIGURE 12: ANSYS Displaced Element Grid for Graphite Specimen

ANSYS RESULTS FOR GRAPHITE SPECIMEN

Load (lbs)	X-Strain (E-6 in/in)	Y-Strain (E-6 in/in)	Variation From Experimental Y-Strain (%)
50	-90	670	4.2
100	-180	1330	5.3
150	-260	2000	5.1
200	-350	2670	6.6
250	-440	3330	6.5
300	-530	4000	7.5
350	-620	4670	7.5

Load (lbs)	X-Stress (psi)	Y-Stress (psi)	Variation From Experimental Y-Stress (%)
50	1.3	658	0.7
100	2.6	1316	0.7
150	3.9	1974	0.6
200	5.2	2362	0.7
250	6.5	3290	0.9
300	7.8	3948	1.1
350	9.1	4606	1.3

Table 11: Ansys Results For Graphite Specimen

```
ANSYS 4.2E
JAN 23 1987
10:15:54
POST1 STRESS
STEP=1
ITER=1
SY
STRESS GLOBAL
ZV=1
DIST=1.37
XF=.25
YF=1.25
MX=4675
MN=-1065
NCON=9
UMIN=-428
VINC=638
```

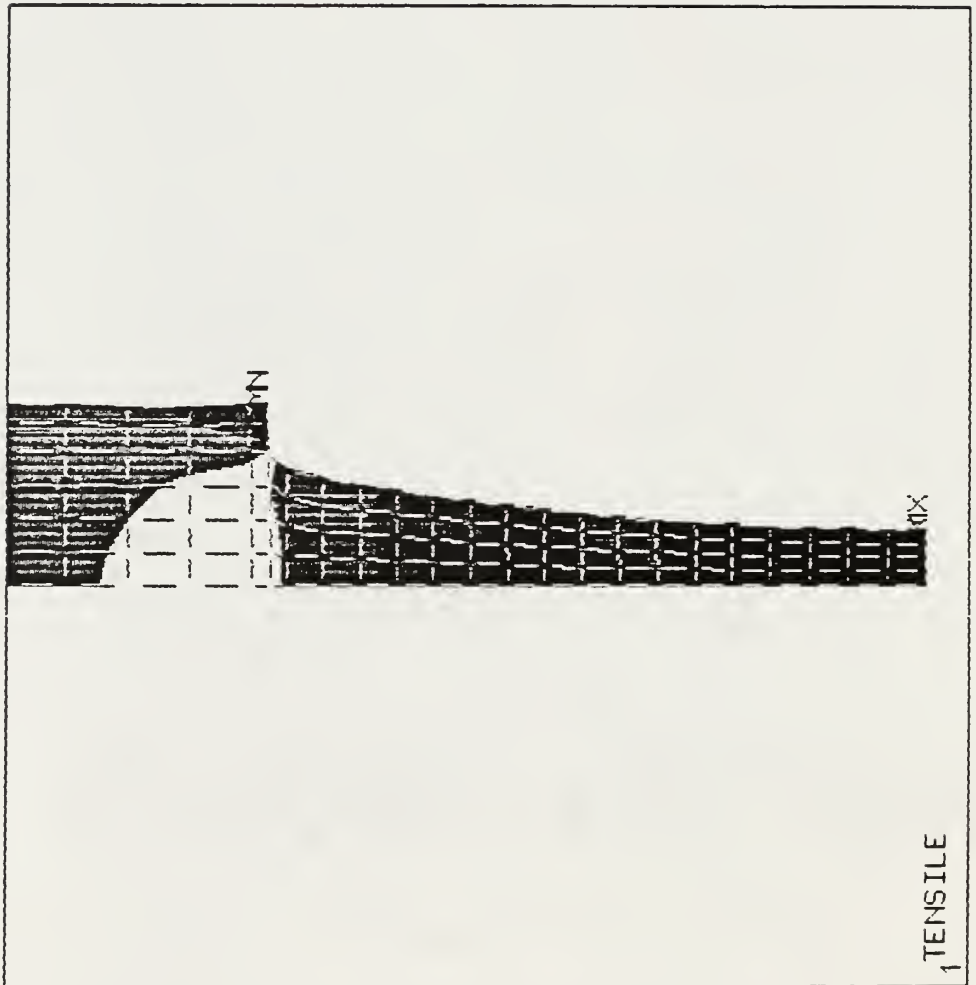

FIGURE 13: ANSYS Stress Distribution for Graphite Specimen

Finite Element Solutions For Coated Specimen
With 0.008 Inch Coating

A data file for the ANSYS finite element analysis of specimen with the 0.008 inch silicon carbide coating was generated. The plot for the element grid emphasizes the thinness of the coating in the poor resolution of the elements for the coating. The element plot is exhibited in Figure 14. The coating elements are long and thin, which is generally not recommended, but since they are not subjected to bending it is acceptable in this application.

The program was run for 50 pound load increments from 0 to 300. As before the finite element approximation is linear, so only the 100 pound load run is discussed in detail. The material properties of the graphite were unchanged. The Young's Modulus of Elasticity for the silicon carbide coating is taken from the reduction of the experimental results as 37E6 psi, versus the reported range of 30 to 65E6 psi. The Poisson's ratio used was 0.13 in/in. Once again, the properties in the program are linear and elastic.

ANSYS 4.2B
JAN 23 1987
9:45:20
POST1 ELEMENTS

ZU=1
DIST=1.37
XF=.25
YF=1.25

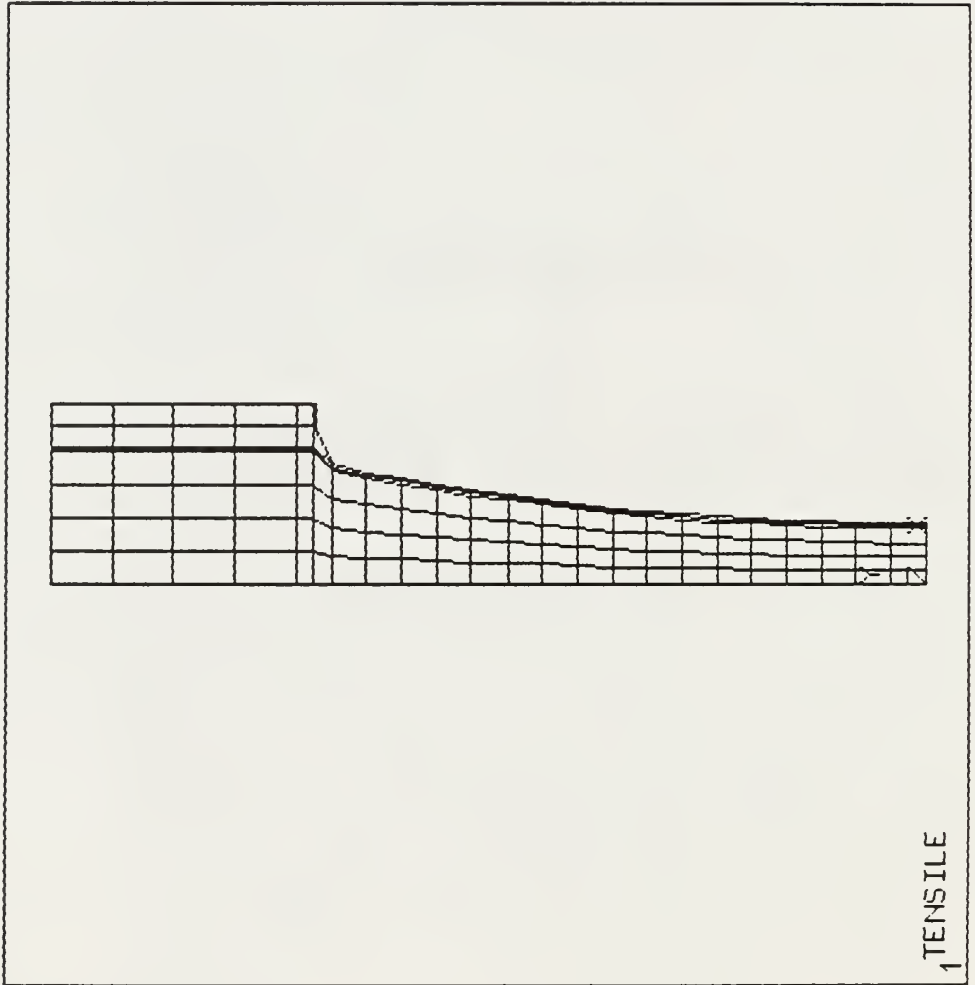

FIGURE 14: ANSYS Element Grid for Graphite Specimen
With a 0.008 Inch Silicon Carbide Coating

Therefore, prediction of the behavior of the product after the coating enters the plastic region (after reaching the yield stress of 27000 psi) is inaccurate.

Again, the output gives elongations (strains) and stresses for each node. The results for the gage section appear in Table 12 along with a comparison with the experimental values. The plot of the displaced elements is generated in Figure 15.

A plot of the stress patterns for the specimen with a 0.008 inch coating appears in Figure 16. Again the small dark area at the lip is in compression. The next area, which includes almost the entire graphite substrate is at a near-zero stress. The lighter area is in the graphite near the surface, and has a small stress. Most of the stress is in the coating itself, just as was the case in the experimental analysis. Again the maximum stress occurs on the outer surface at the center of the specimen. Another point of interest is the nearly constant strain through the cross section, agreeing with the assumption made in the determination of the material properties of

ANSYS RESULTS FOR COATED SPECIMEN
0.008 INCH COATING

Load = 100 Pounds

Location (x,y) in.	X-Strain (E-6 in/in)	Y-Strain (E-6 in/in)	Variation From Experimental Y-Strain (%)
0,0.031	- 0	266	2.2
0,0.062	- 9	266	2.2
0,0.093	- 17	267	1.8
0,0.124	- 26	267	1.8
0,0.155	- 35	268	1.5
0,0.159	- 36	269	1.1
0,0.163	- 37	269	1.1

Location (x,y) in.	X-Stress (psi)	Y-Stress (psi)	Variation From Experimental Y-Stress (%)
0,0.031	2	266	
0,0.062	2	266	
0,0.093	2	267	
0,0.124	1	268	
0,0.155	1	5093	
0,0.159	1	9934	
0,0.163	3	9943	10.9

Table 12: ANSYS Results For 0.008 Inch Coating

ANSYS 4.28
JAN 23 1987
9:49:35
POST1 DISPL.
STEP=1
ITER=1
ZU=1
DIST=1.37
XF=.25
YF=1.25
DMAX=.00073
DSCA=188

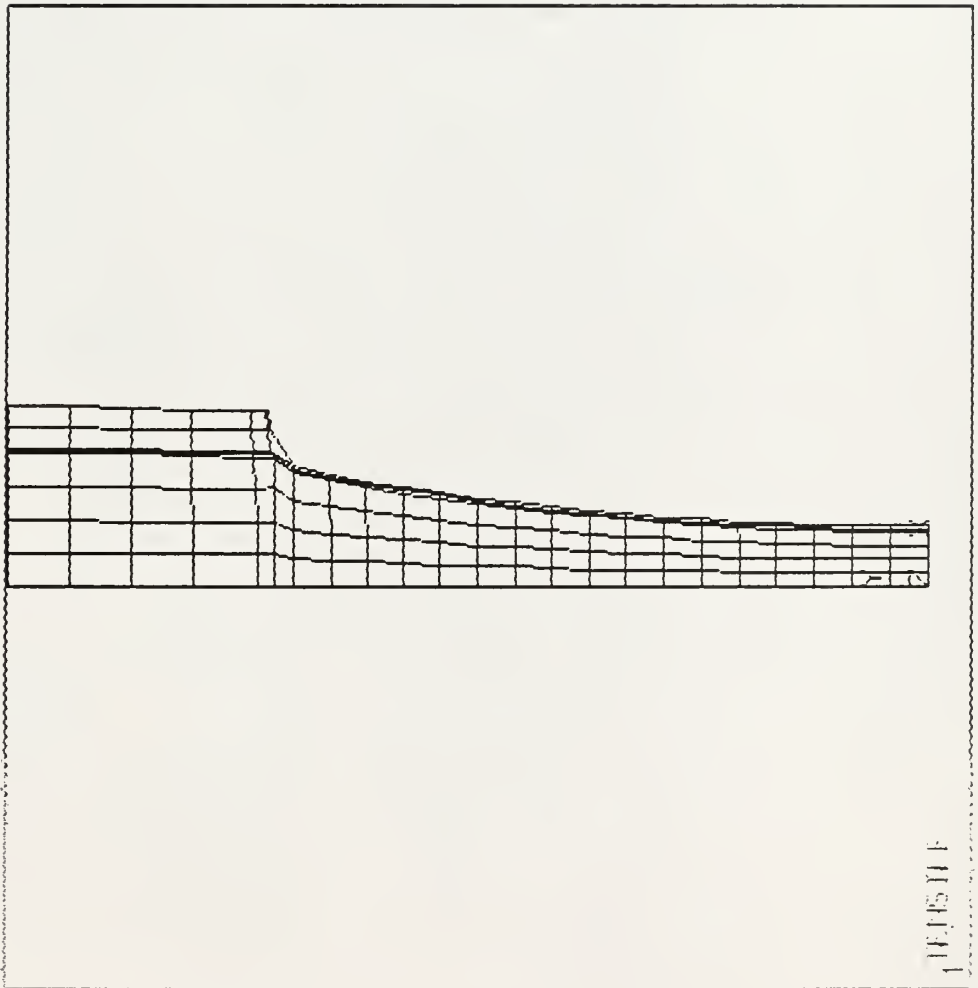

FIGURE 15: ANSYS Displaced Element Grid for Graphite Specimen With a 0.008 Inch Silicon Carbide Coating

```
ANSYS 4.2B  
JAN 23 1987  
10:27:04  
POST1 STRESS  
STEP=1  
ITER=1  
SY  
STRESS GLOBAL  
ZU=1  
DIST=1.37  
XF=.25  
YF=1.25  
MX=10087  
MN=-266  
NCON=9  
UMIN=882  
UMAX=1151
```

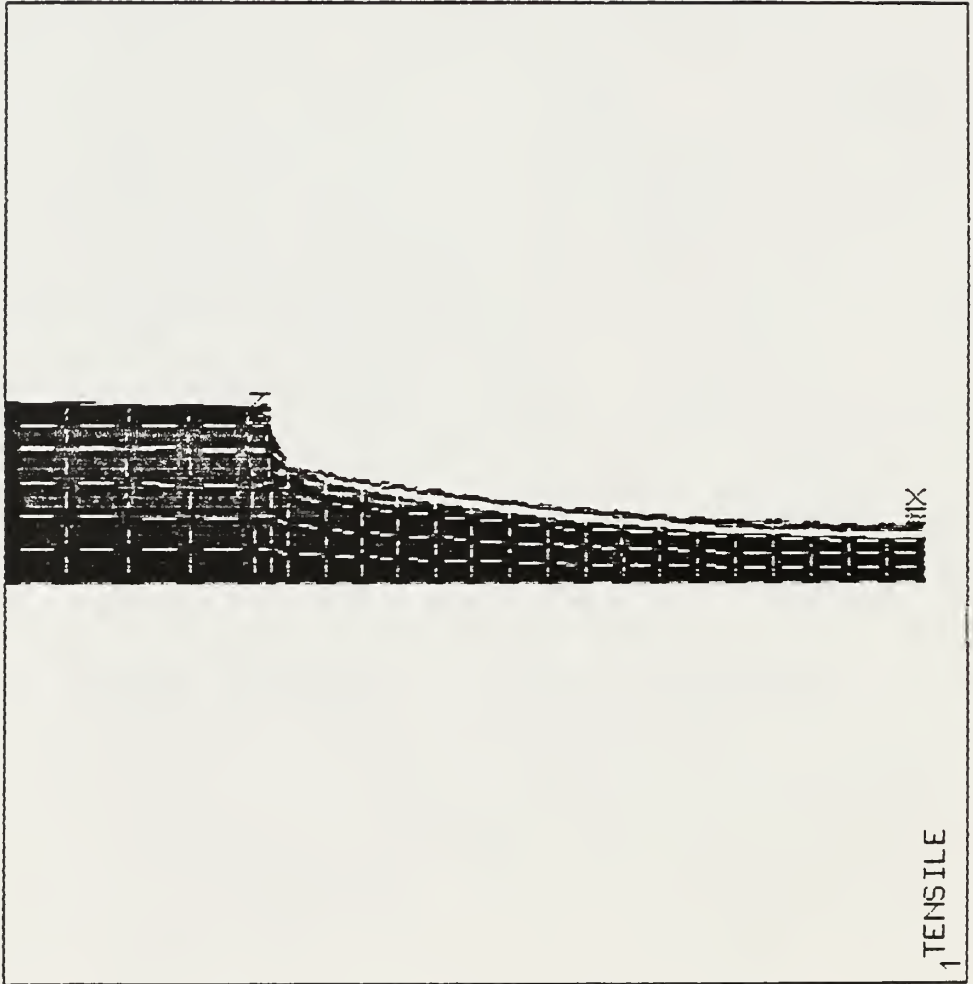

FIGURE 16: ANSYS Stress Distribution for Graphite Specimen With a 0.008 Inch Silicon Carbide Coating

silicon carbide.

Finite Element Solutions For Coated Specimen
With 0.016 Inch Coating

Another data file was generated for the ANSYS finite element program simulating the specimen with the 0.016 inch coating. Again the thin coating with respect to the substrate thickness causes poor resolution in the element plot generated in Figure 17. The same number of elements are used in this example as for the 0.008 inch coating, but the coating elements are twice as thick.

Again the loading in the file corresponds to that of a 100 pound tensile load and is applied as a pressure on the under side of the lip. The same material properties were used for this run as for the 0.008 inch coating run. The Young's Modulus for graphite was $1.0E6$ psi. The Poisson's ratio for the graphite was 0.09. The Young's Modulus of Elasticity and Poisson's ratio for the silicon carbide coating were $37E6$ psi and 0.13 respectively.

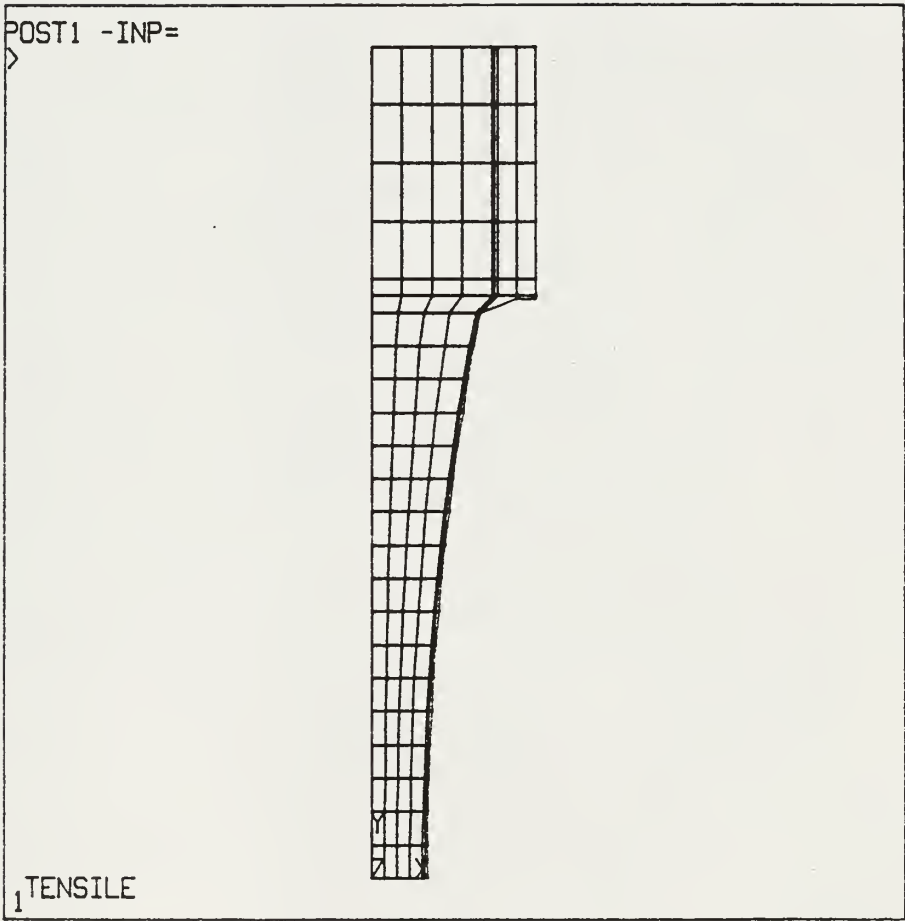

ANSYS 4.2B
FEB 25 1987
8:56:57
POST1 ELEMENTS

ZV=1
DIST=1.37
XF=.25
YF=1.25

FIGURE 17: ANSYS Element Grid for Graphite Specimen
With a 0.016 Inch Silicon Carbide Coating

Since the specimen with the 0.016 inch coating thickness broke at the root before yielding of the gage section occurred, the values from the finite element solution are accurate until fracture. The results for elongations (strains) and stresses at the gage (center) section along with a comparison to the experimentally determined values appears in Table 13. The plot of the displaced elements generated by ANSYS for the coated specimen is presented in Figure 18.

The plot of the stress patterns appears in Figure 19. The same stress patterns appear as in the 0.008 inch coating except the area of low stress (light strip along the outer surface but within the graphite) in the graphite substrate is thinner suggesting that the coating is supporting even more of the load. Again the program suggests that the maximum stress is in the gage section. Failure, however, occurred at the root of the specimen. The finite element program predicts failure at the center section. The root failure is attributed to the stress concentration and coating application problems of interior corners

ANSYS RESULTS FOR COATED SPECIMEN
0.016 INCH COATING

Load = 100 Pounds

Location (x,y) in.	X-Strain (psi)	Y-Strain (psi)	Variation From Experimental Y-Strain (%)
0,0.031	- 0	145	5.5
0,0.062	- 0	145	5.5
0,0.093	- 1	145	5.5
0,0.124	- 1	145	5.5
0,0.155	- 2	146	6.1
0,0.163	- 2	146	6.1
0,0.171	- 2	147	6.8

Location (x,y) in.	X-Stress (E-6 in/in)	Y-Stress (E-6 in/in)	Variation From Experimental Y-Stress (%)
0,0.031	1	145	
0,0.062	1	145	
0,0.093	1	145	
0,0.124	1	146	
0,0.155	0	2773	
0,0.163	1	5409	
0,0.171	3	5418	1.6

Table 13: ANSYS Results For 0.016 Inch Coating

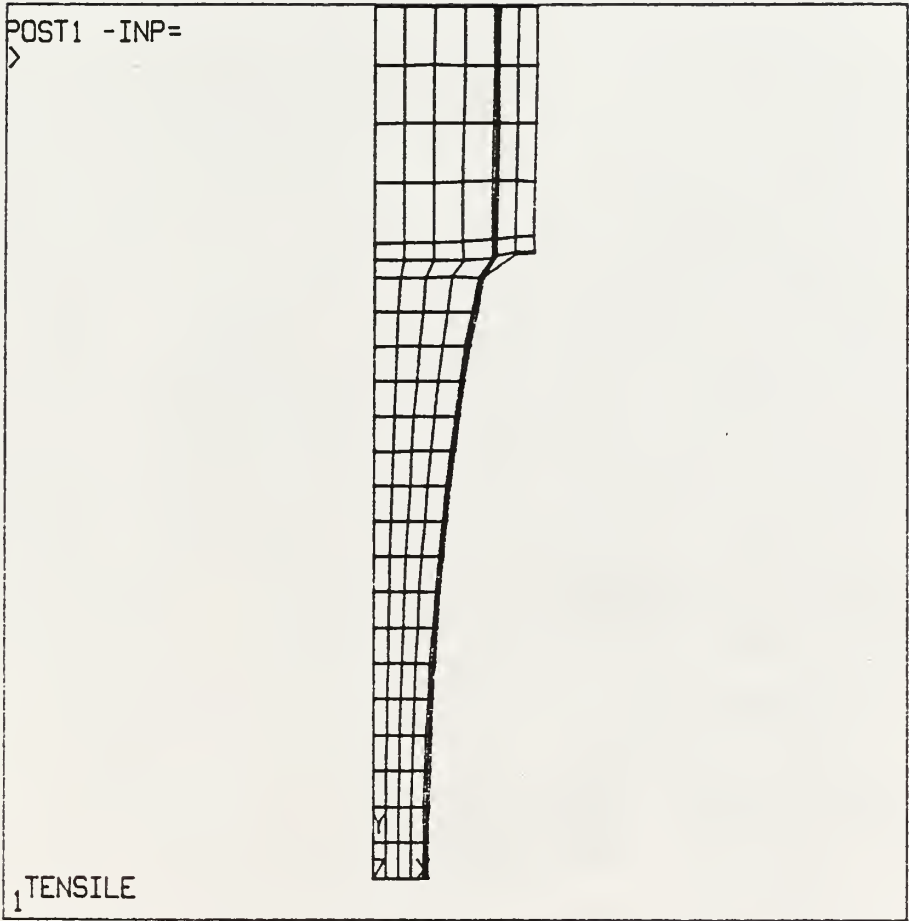

ANSYS 4.2B
FEB 25 1987
8:59:06
POST1 DISPL.
STEP=1
ITER=1

ZV=1
DIST=1.37
XF=.25
YF=1.25
DMAX=.000248
DSCA=555

FIGURE 18: ANSYS Displaced Element Grid for Graphite Specimen With a 0.016 Inch Silicon Carbide Coating

```

ANSYS 4.2B
JAN 23 1987
9:56:42
POST1 STRESS
STEP=1
ITER=1
SY
STRESS GLOBAL
ZU=1
DIST=1.37
XF=.25
YF=1.25
MX=16403
MN=-2322
NCON=9
VMIN=-243
VINC=2081

```

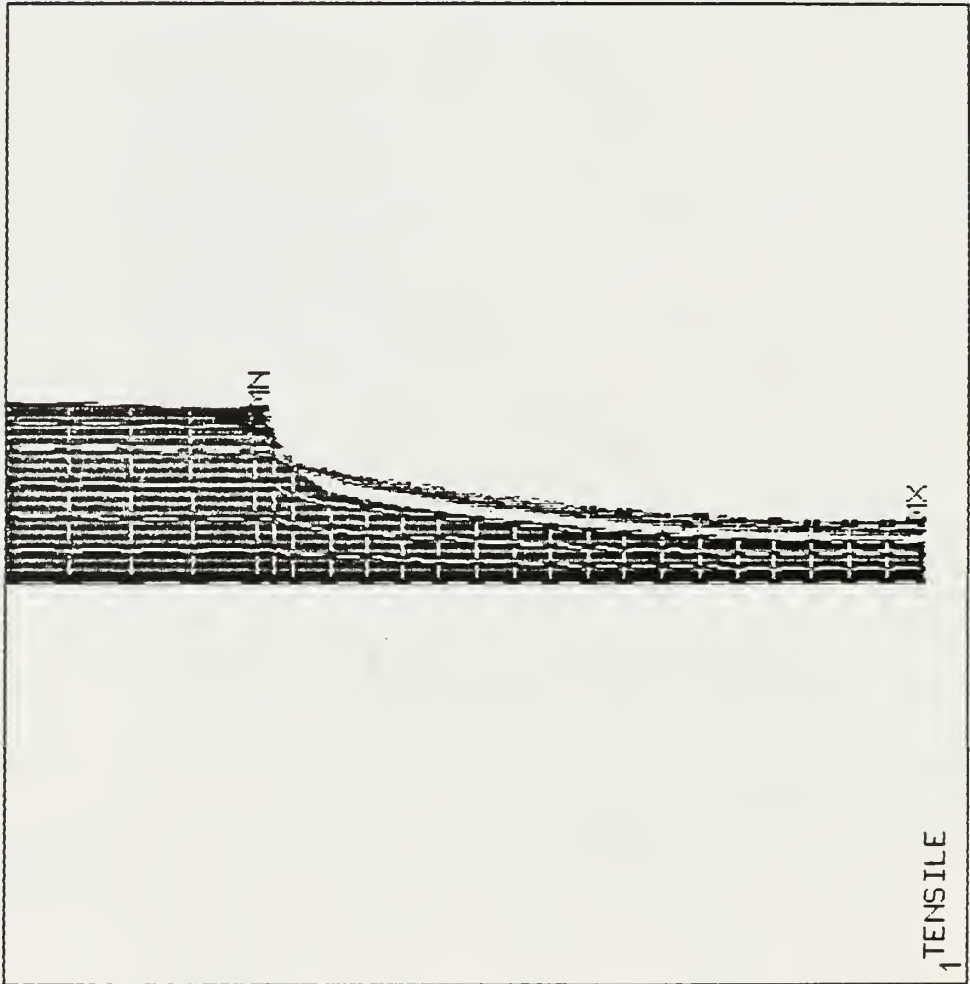

FIGURE 19: ANSYS Stress Distribution for Graphite Specimen With a 0.016 Inch Silicon Carbide Coating

explained by Munger [11] which are not considered by the finite element package. Figure 20 plots the load (effective stress) against the strain for all three sample types. The dashed lines represent the ANSYS finite element approximations.

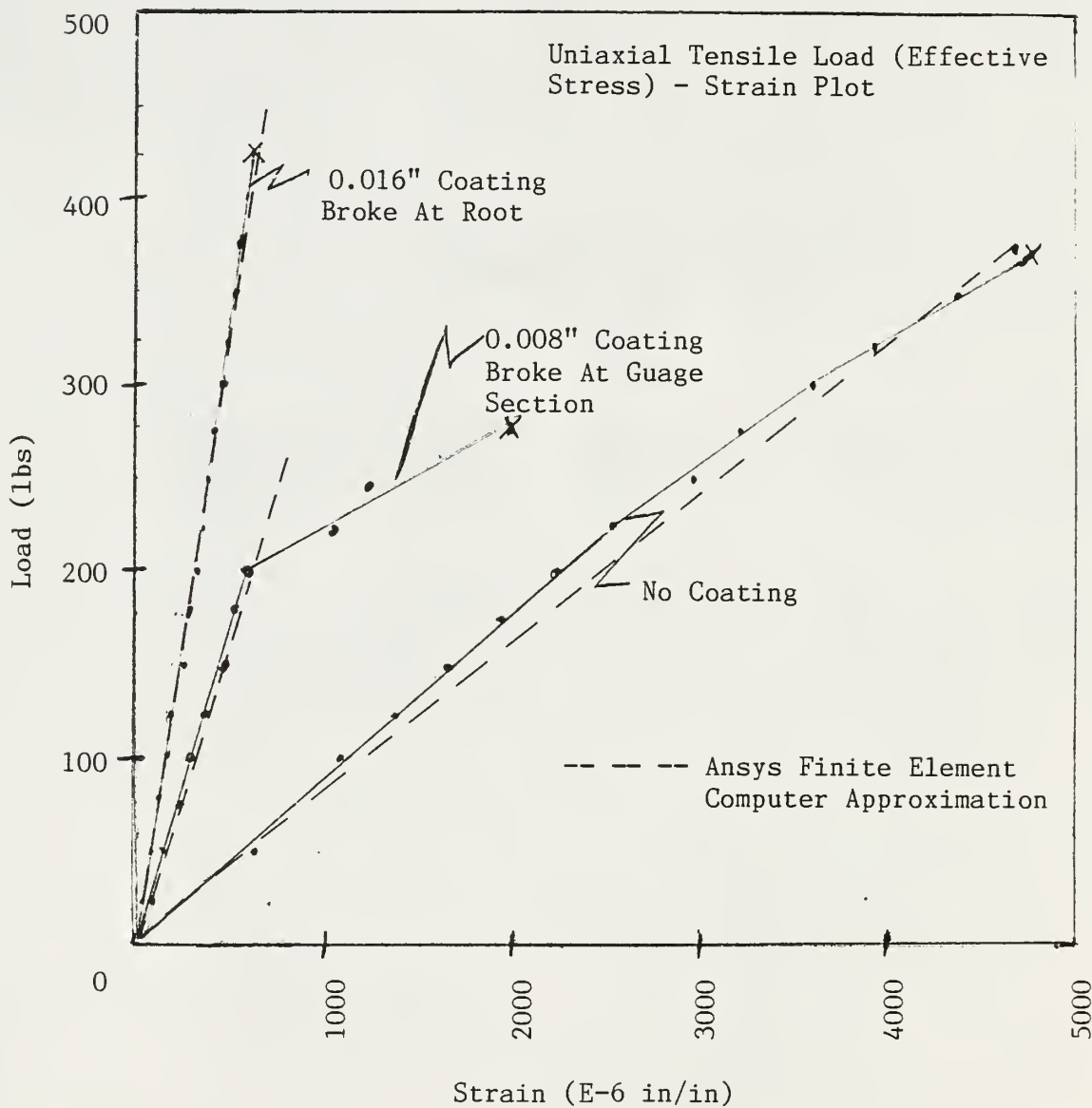

FIGURE 20: Uniaxial Tensile Load (Effective Stress) - Strain; Experimental and Finite Element

CHAPTER V

SUMMARY AND CONCLUSIONS

Summary

The material property results for both the graphite substrate and the silicon carbide coating obtained were presented in the previous chapter. The test apparatus and methodology for the uniaxial tensile tests was that suggested by the ASTM Standard C565-78. The resulting values are believed to be representative of the material properties of the specimen.

The values measured for the graphite substrate are consistent with those proposed by the manufacturer. The values for the graphite material were determined by classic stress and strain transformations for the three element gage employed. The values determined in the uniaxial investigations were then used to represent the graphite in further testing.

Uniaxial tests were conducted on the coated specimen. Theories based on interference fit of compound cylinders and thin wall cylinder approximations were used to determine the material properties of the silicon carbide material used as a coating. The resulting values fell within the ranges suggested for CVD silicon carbide and were assumed representative of the material. Design criteria involving the separation of the stresses are then derived.

Conclusions

A proposed methodology for design using coated products requires consideration of the material properties and loading of the coating and the substrate individually. The first step in design using a product with a coating is the determination of the material properties of both the substrate and coating materials. The second step is a separation of the stresses in the coating from those in the substrate. This can be done by the compound cylinder

equations discussed within this paper. In the design, if the maximum stress of either the substrate or the coating is exceeded, the product will suffer catastrophic failure. If available, a finite element computer routine may then be used as a verification tool as well as to help prevent any overdesign.

BIBLIOGRAPHY

1. Avilxin, V. I., "Assymptotic Analysis of the Plane Contact Problem of Elasticity for a Two-Layer Foundatiion," Journal of Applied Mechanics and Technical Physics, Vol. 26, No. 1, Jan.-Feb. 1985, pp. 122-127.
2. Bascom, W. D., J. Oronhnik and C. O. Timmons, "Fracture Testing of Coatings," American Chemical Society Div. of Organic Coatings and Plastics Chemistry Papers, Vol. 37, No. 1, 1977, pp. 833-836.
3. Beer, F. P., and E. R. Johnston, Jr. Mechanics of Materials, McGraw-Hill Book Company, 1981.
4. Personal Interview With T. Driscoll Metallurgist, Texas Instruments, Dallas, Texas, Feb. 20, 1987.
5. Greenstreet, W. L., J. E. Smith and G. T. Yahr, "Mechanical Properties of EGCR-Type AGOT Graphite," Carbon, Vol. 7, 1969, pp. 15-45.
6. Hill, L. W., "Stress Analysis - A Tool for Understanding Coatings Performance," Progress in Organic Coatings, Vol. 5, No. 3, May 1978 pp. 277-294.
7. Hu, K. K. and S. E. Swartz, "A Proposed Generalized Material Failure Theory," Proc. of the 15th Midwestern Mech. Conf., Univ. of Il. at Chicago Circle, Chicago, IL, March 23-25, 1977, pp. 144-147
8. Hu, K. K., S. E. Swartz and C. L. Huang, "A Proposed Generalized Constitutive Equation for Nonlinear Para-isotropic Materials," Research in Nonlinear Structural and Solid Mechanics, Research-in-progress Papers Presented at a Symposium Held at Washington, D.C., October 6-8, 1980, NASA Conference Publication 2147, pp. 527-528.

9. Jayatilaka, A., Fracture of Engineering Brittle Materials, Applied Science Publishers, Ltd., London, 1979.
10. Kuoinov, V. V., F. I. Kitaev and A. G. Tsidulko, "Strength Characteristics of Plasma-sprayed Coatings From Mixed Nickel-aluminum Powders," Soviet Powder Metallurgy and Metal Ceramics (English Translation), Vol. 14, No. 8, Aug. 1975, pp. 637-642.
11. Munger, C. G., "Understanding Protective Coating Failures - 1. Coating Formulation and Selection," Plant Engineering, Vol. 30, No. 8, April 15, 1976, pp. 67-70.
12. Munger, C. G., "Understanding Protective Coating Failures - 2. Substrate Material and Condition," Plant Engineering, Vol. 30, No. 9, April 29, 1976, pp. 223-226.
13. Munger, C. G., "Understanding Protective Coating Failures - 3. Coating Application Procedures," Plant Engineering, Vol. 30, No. 10, May 13, 1976, pp. 133-135.
14. Rowley, J. C., "Description of Design Requirements for Graphite Components," Proceedings of the Conference on Continuum Aspects of Graphite Design, November 9-12, 1970, Gatlinburg, Tennessee, CONF-701105.
15. Sedlacek, R. and F. A. Holden, "Methods of Tensile Testing of Brittle Materials," Review of Scientific Instruments, Vol. 3, No. 3, 1962, pp. 289-300.
16. Swartz, S. E., K. K. Hu, C. L. Huang and B. L. Jones, "An Apparatus for Tensile Testing of Brittle Materials," Experimental Mechanics, March 1979, pp. 109-111.
17. Tang, P. Y., "A Recommendation of a Triaxial Failure Theory for Graphite," U.S. Department of Commerce, Department of Energy, No. GA-A1533 UC-77, May 1979.

18. Trester, P. W., G. R. Hopkins, J. L. Kaae and J. Whitley, "Performance Results On a C-SiC Alloy Coating Chemically Vapor-Deposited Onto a Graphite Substrate," Thin Solid Films, Vol. 108, 1983, pp. 383-393.
19. Vigue, J. C., "The Basic Principles of Chemical Vapor Deposition," Science and Technology of Surface Coatings, 1972, pp. 149-158.

APPENDIX

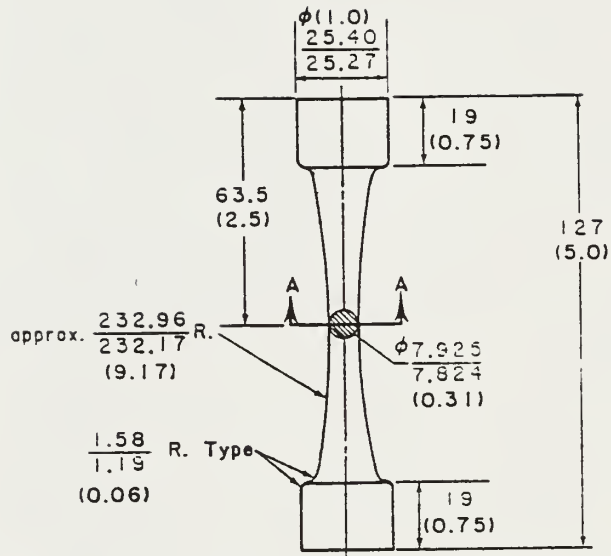

Reprinted from ASTM Standard C565-78

ASTM Standard for Tensile Testing
of Brittle Materials

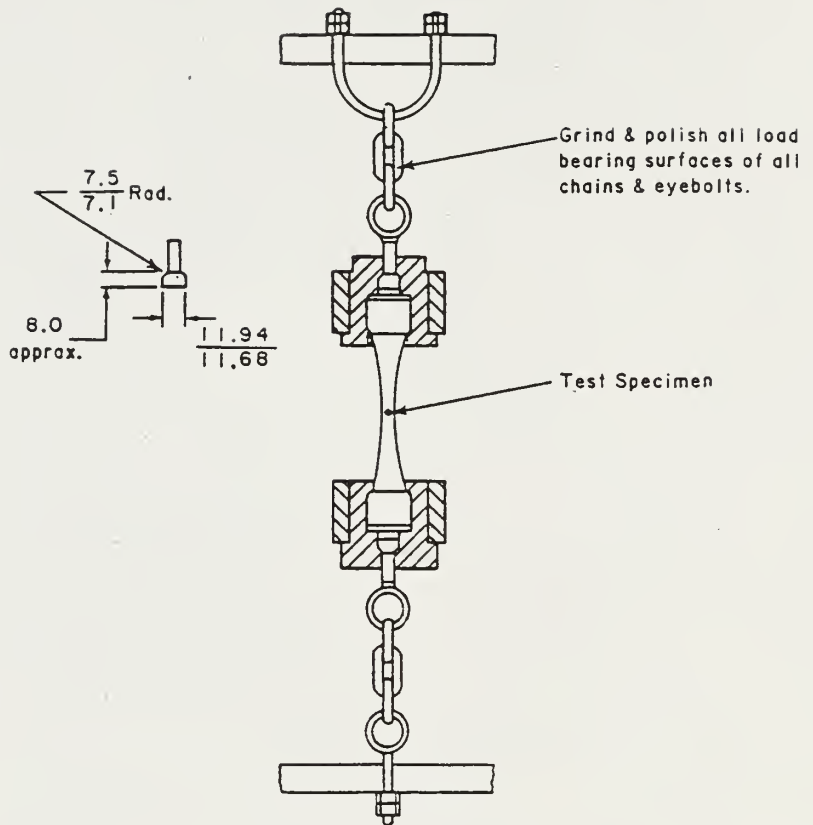

ASTM Standard for Tensile Testing
of Brittle Materials

GRAPHITE TENSILE TEST RESULTS
VALUES FOR UNCOATED SPECIMEN

Sample 4

Load (lbs)	Strain 1 (E-6 in/in)	Strain 2 (E-6 in/in)	Phi (deg)	Poisson (in/in)
20	245	-28	3.0	0.11
40	406	-40	2.7	0.10
65	639	-73	4.2	0.11
80	814	-73	4.8	0.08

Guage failure at 100 lbs.

Table 1: Graphite Strain Results

GRAPHITE TENSILE TEST RESULTS

VALUES FOR UNCOATED SPECIMEN

Sample 5

Load (lbs)	Strain 1 (E-6 in/in)	Strain 2 (E-6 in/in)	Phi (deg)	Poisson (in/in)
25	733	-125	-13.3	0.11
50	1042	-169	-13.2	0.11
75	1361	-206	-13.2	0.10
100	1684	-229	-13.2	0.08
125	2024	-254	-13.2	0.07
150	2346	-288	-13.2	0.07
175	2667	-323	-13.2	0.07
200	3005	-350	-13.1	0.06
225	3368	-380	-13.1	0.06
250	3670	-407	-13.0	0.06
275	4033	-434	-12.8	0.06
300	4403	-457	-12.7	0.05
325	4773	-486	-12.6	0.05
350	5147	-1068	-19.8	0.05

Sample 6

Load (lbs)	Strain 1 (E-6 in/in)	Strain 2 (E-6 in/in)	Phi (deg)	Poisson (in/in)
50	604	-108	0.6	0.17
75	836	-130	-0.5	0.15
100	1071	-158	-0.8	0.15
125	1345	-183	-1.0	0.14
150	1630	-205	-1.2	0.13
175	1898	-227	-1.0	0.12
200	2211	-249	-1.5	0.11
225	2532	-272	-1.7	0.11
250	2879	-297	-1.8	0.10
275	3204	-317	-1.8	0.10
300	3586	-339	-2.0	0.10
325	3930	-360	-1.9	0.09
350	4356	-381	-1.9	0.09
375	4722	-402	-1.9	0.08

Table 1: Graphite Strain Results

GRAPHITE TENSILE TEST RESULTS
VALUES FOR UNCOATED SPECIMEN

Sample 5

Load (lbs)	Stress 1 (psi)	Stress 2 (psi)	E (E6 psi)
25	350	-19	0.48
50	701	-38	0.68
75	1051	-58	0.83
100	1402	-78	0.87
125	1753	-117	0.90
150	2104	-134	0.92
175	2453	-152	0.94
200	2802	-171	0.95
225	3178	-185	0.96
250	3497	-199	0.96
275	3842	-214	0.95
300	4188	-226	0.95
325	4532	-238	0.95
350	5705	-736	0.95

Sample 6

Load (lbs)	Stress 1 (psi)	Stress 2 (psi)	E (E6 psi)
50	662	-0.06	1.10
75	993	-0.09	1.19
100	1325	-0.24	1.24
125	1656	-0.52	1.23
150	1988	-0.87	1.22
175	2319	-0.65	1.22
200	2651	-2.02	1.20
225	2983	-2.56	1.18
250	3315	-3.35	1.15
275	3647	-3.79	1.14
300	3979	-4.96	1.11
325	4310	-4.96	1.10
350	4642	-5.33	1.07
375	4973	-5.53	1.05

Table 2: Graphite Strain Results

GRAPHITE TENSILE TEST RESULTS
VALUES FOR UNCOATED SPECIMEN

Sample 4

Load (lbs)	Stress 1 (psi)	Stress 2 (psi)	E (E6 psi)
20	265	-0.75	1.08
40	531	-1.18	1.31
65	865	-4.67	1.36
80	1067	-7.63	1.32

Table 2: Graphite Stress Results

GRAPHITE TENSILE TEST RESULTS
 VALUES FOR SPECIMEN WITH 0.008 INCH COATING

Sample 2 Side 1

Load (lbs)	Strain 1 (E-6 in/in)	Strain 2 (E-6 in/in)	Phi (deg)	Poisson (in/in)
25	83	-16	-11.4	0.16
50	152	-31	- 9.0	0.18
75	271	-54	- 8.7	0.18
100	538	-93	- 4.9	0.17
125	897	-126	- 6.0	0.13
150	1175	-152	- 6.2	0.12
175	1488	-175	- 5.5	0.11
200	1945	-236	- 8.9	0.10
225	2266	-276	- 8.0	0.10
250	2655	-286	- 7.5	0.09

Sample 2 Side 2

Load (lbs)	Strain 1 (E-6 in/in)	Strain 2 (E-6 in/in)	Phi (deg)	Poisson (in/in)
25	213	-38	11.6	0.14
50	407	-88	15.5	0.14
75	539	-226	26.1	0.20
100	565	-278	28.6	0.23
125	621	-303	28.0	0.24
150	760	-398	29.5	0.25
175	922	-528	31.1	0.26
200	1243	-401	21.6	0.17
225	1465	-462	21.1	0.18
250	2000	-245	8.1	0.10

Table 4: Coated Product Effective Strain

GRAPHITE TENSILE TEST RESULTS
VALUES FOR SPECIMEN WITH 0.008 INCH COATING

Sample 3 Side 1

Load (lbs)	Strain 1 (E-6 in/in)	Strain 2 (E-6 in/in)	Phi (deg)	Poisson (in/in)
25	164	-30	1.2	0.18
50	339	-56	- 0.2	0.17
75	544	-77	- 1.7	0.14
100	814	-100	- 3.4	0.12
125	1089	-109	- 6.2	0.09
150	1280	-164	1.2	0.13
175	1376	-241	8.2	0.15
200	1490	-289	9.2	0.17
225	1914	-316	6.5	0.15

Sample 3 Side 2

Load (lbs)	Strain 1 (E-6 in/in)	Strain 2 (E-6 in/in)	Phi (deg)	Poisson (in/in)
25	141	-19	-13.8	0.08
50	272	-37	-13.9	0.08
75	432	-61	-14.6	0.07
100	631	- 89	-14.9	0.07
125	991	-157	-16.6	0.07
150	1177	-110	- 9.7	0.06
175	1384	-117	-10.0	0.05
200	1550	-141	-10.6	0.06
225	1703	-103	- 3.3	0.06

Table 4: Coated Product Effective Strain

GRAPHITE TENSILE TEST RESULTS
 VALUES FOR SPECIMEN WITH 0.008 INCH COATING

Sample 3 Side 1

Load (lbs)	Strain 1 (E-6 in/in)	Strain 2 (E-6 in/in)	Phi (deg)	Poisson (in/in)
25	164	-30	1.2	0.18
50	339	-56	- 0.2	0.17
75	544	-77	- 1.7	0.14
100	814	-100	- 3.4	0.12
125	1089	-109	- 6.2	0.09
150	1280	-164	1.2	0.13
175	1376	-241	8.2	0.15
200	1490	-289	9.2	0.17
225	1914	-316	6.5	0.15

Sample 3 Side 2

Load (lbs)	Strain 1 (E-6 in/in)	Strain 2 (E-6 in/in)	Phi (deg)	Poisson (in/in)
25	141	-19	-13.8	0.08
50	272	-37	-13.9	0.08
75	432	-61	-14.6	0.07
100	631	- 89	-14.9	0.07
125	991	-157	-16.6	0.07
150	1177	-110	- 9.7	0.06
175	1384	-117	-10.0	0.05
200	1550	-141	-10.6	0.06
225	1703	-103	- 3.3	0.06

Table 4: Coated Product Effective Strain

GRAPHITE TENSILE TEST RESULTS
VALUES FOR SPECIMEN WITH 0.008 INCH COATING

Sample 2 Side 1

Load (lbs)	Stress 1 (psi)	Stress 2 (psi)	E (E6 psi)
25	306	-12	3.68
50	603	-15	3.97
75	903	-20	3.34
100	1185	- 9	2.20
125	1487	-17	1.66
150	1785	-21	1.52
175	2077	-19	1.40
200	2400	-47	1.23
225	2700	-53	1.19
250	2993	-52	1.13

Sample 2 Side 2

Load (lbs)	Stress 1 (psi)	Stress 2 (psi)	E (E6 psi)	Poisson
25	307	-13	1.45	
50	637	-49	1.58	
75	1161	-279	2.25	
100	1673	-497	3.16	
125	2047	-577	3.52	
150	2591	-826	3.68	
175	3238	-1180	3.85	
200	2791	-439	2.31	
225	3107	-461	2.17	
250	3002	-61	1.50	

Table 5: Coated Product Effective Stress

GRAPHITE TENSILE TEST RESULTS
VALUES FOR SPECIMEN WITH 0.008 INCH COATING

Sample 3 Side 1

Load (lbs)	Stress 1 (psi)	Stress 2 (psi)	E (E6 psi)
25	294	- 0	1.79
50	588	- 0	1.73
75	883	- 1	1.62
100	1180	- 4	1.45
125	1488	-18	1.37
150	1765	- 1	1.38
175	2102	-44	1.53
200	2417	-64	1.63
225	2682	-36	1.40

Sample 3 Side 2

Load (lbs)	Stress 1 (psi)	Stress 2 (psi)	E (E6 psi)
25	312	-19	2.23
50	626	-38	2.30
75	946	-64	2.20
100	1267	-90	2.02
125	1613	-142	1.64
150	1818	-53	1.55
175	2124	-66	1.54
200	2437	-85	1.58
225	2655	- 9	1.56

Table 5: Coated Product Effective Stress

GRAPHITE TENSILE TEST RESULTS
VALUES FOR SPECIMEN WITH 0.016 INCH COATING

Sample 2 Side 1

Load (lbs)	Strain 1 (E-6 in/in)	Strain 2 (E-6 in/in)	Phi (deg)	Poisson (in/in)
25	18	- 1	4.5	0.06
50	38	- 4	1.4	0.11
75	64	- 5	- 2.9	0.08
100	85	- 8	- 2.2	0.09
125	107	-11	- 1.9	0.10
150	129	-13	- 2.0	0.10
175	153	-15	- 1.7	0.10
200	174	-18	- 1.5	0.10
225	197	-20	- 1.5	0.10
250	222	-23	- 1.3	0.10
275	245	-26	- 1.2	0.10
300	267	-29	- 1.0	0.10
325	292	-31	- 1.0	0.10
350	312	-33	- 0.8	0.10
375	335	-36	- 0.5	0.10
400	358	-38	- 0.6	0.10

Sample 2 Side 2

Load (lbs)	Strain 1 (E-6 in/in)	Strain 2 (E-6 in/in)	Phi (deg)	Poisson (in/in)
25	35	- 4	-12.0	0.06
50	61	- 8	- 9.2	0.10
75	82	-11	- 8.4	0.11
100	108	-16	- 8.6	0.12
125	135	-19	- 8.6	0.12
150	162	-23	- 8.6	0.12
175	190	-27	- 8.6	0.12
200	214	-30	- 8.7	0.11
225	241	-33	- 8.7	0.11
250	267	-37	- 8.5	0.11
275	292	-40	- 8.5	0.12
300	316	-44	- 8.5	0.12
325	344	-48	- 8.5	0.12
350	370	-50	- 8.6	0.11
375	396	-54	- 8.5	0.11
400	423	-57	- 8.5	0.11

Table 6: Coated Product Effective Strain

GRAPHITE TENSILE TEST RESULTS
VALUES FOR SPECIMEN WITH 0.016 INCH COATING

Sample 3		Side 1		
Load (lbs)	Strain 1 (E-6 in/in)	Strain 2 (E-6 in/in)	Phi (deg)	Poisson (in/in)
25	21	- 5	6.5	0.24
50	38	- 9	7.3	0.21
75	58	-11	5.8	0.19
100	76	-15	6.0	0.18
125	94	-17	5.5	0.17
150	112	-19	5.5	0.16
175	132	-21	5.4	0.15
200	153	-24	5.0	0.15
225	171	-27	5.2	0.15
250	192	-30	4.9	0.15
275	211	-33	5.0	0.15
300	229	-35	4.8	0.14
325	250	-38	4.8	0.15
350	270	-41	4.7	0.15
375	290	-43	4.6	0.14
400	309	-46	4.8	0.14
425	329	-49	4.6	0.14
450	349	-51	4.5	0.14
475	368	-54	4.5	0.14

Table 6: Coated Product Effective Strain

GRAPHITE TENSILE TEST RESULTS
VALUES FOR SPECIMEN WITH 0.016 INCH COATING

Sample 3		Side 2		
Load (lbs)	Strain 1 (E-6 in/in)	Strain 2 (E-6 in/in)	Phi (deg)	Poisson (in/in)
25	34	- 5	2.1	0.15
50	62	- 8	3.3	0.13
75	91	-10	3.1	0.11
100	119	-14	3.9	0.11
125	150	-16	4.0	0.10
150	180	-19	3.9	0.10
175	210	-21	4.1	0.10
200	241	-24	4.2	0.10
225	270	-27	4.3	0.10
250	299	-30	4.2	0.09
275	327	-32	4.2	0.09
300	356	-35	4.3	0.09
325	385	-39	4.5	0.10
350	414	-42	4.5	0.09
375	444	-45	4.5	0.10
400	472	-47	4.7	0.09
425	501	-51	4.7	0.09
450	530	-53	4.7	0.09
475	563	-55	4.7	0.09

Table 6: Coated Product Effective Strain

GRAPHITE TENSILE TEST RESULTS
VALUES FOR SPECIMEN WITH 0.016 INCH COATING

		Sample 2	Side 1		
Load (lbs)	Stress 1 (psi)	Stress 2 (psi)	Stress 2 (psi)	E (E6 psi)	
25	275	- 2		15.2	
50	548	- 0		14.4	
75	823	- 2		12.8	
100	1096	- 2		12.9	
125	1370	- 2		12.8	
150	1644	- 2		12.7	
175	1939	- 2		12.7	
200	2191	- 1		12.6	
225	2465	- 2		12.5	
250	2738	- 1		12.3	
275	3023	- 1		12.3	
300	3285	- 1		12.3	
325	3559	- 1		12.2	
350	3833	- 1		12.3	
375	4106	- 0		12.3	
400	4380	- 0		12.2	

		Sample 2	Side 2		
Load (lbs)	Stress 1 (psi)	Stress 2 (psi)	Stress 2 (psi)	E (E6 psi)	
25	286	-12		8.0	
50	562	-15		9.1	
75	839	-18		10.2	
100	1120	-25		10.3	
125	1401	-32		10.4	
150	1681	-39		10.4	
175	1982	-45		10.4	
200	2242	-52		10.5	
225	2522	-59		10.5	
250	2800	-63		10.5	
275	3092	-70		10.6	
300	3359	-74		10.6	
325	3640	-80		10.6	
350	3921	-89		10.6	
375	4198	-93		10.6	
400	4479	-99		10.6	

Table 7: Coated Product Effective Stress

GRAPHITE TENSILE TEST RESULTS
VALUES FOR SPECIMEN WITH 0.016 INCH COATING

Sample 3 Side 1

Load (lbs)	Stress 1 (psi)	Stress 2 (psi)	E (E6 psi)
25	277	- 4	13.0
50	556	- 9	14.4
75	829	- 9	14.4
100	1107	-12	14.6
125	1381	-13	14.7
150	1657	-15	14.8
175	1933	-18	14.6
200	2206	-17	14.4
225	2484	-21	14.5
250	2757	-20	14.3
275	3057	-24	14.4
300	3309	-24	14.4
325	3583	-25	14.3
350	3858	-26	14.3
375	4132	-26	14.3
400	4410	-31	14.3
425	4683	-30	14.2
450	4957	-30	14.2
475	5233	-32	14.2

Table 7: Coated Product Effective Stress

GRAPHITE TENSILE TEST RESULTS
VALUES FOR SPECIMEN WITH 0.016 INCH COATING

Sample 3 Side 2

Load (lbs)	Stress 1 (psi)	Stress 2 (psi)	E (E6 psi)
25	274	- 0	8.0
50	549	- 2	8.8
75	823	- 2	9.0
100	1100	- 5	9.2
125	1375	- 7	9.1
150	1650	- 8	9.2
175	1926	-10	9.2
200	2202	-12	9.1
225	2477	-14	9.2
250	2752	-15	9.2
275	3049	-16	9.4
300	3303	-19	9.4
325	3580	-22	9.3
350	3855	-24	9.3
375	4132	-26	9.3
400	4409	-30	9.3
425	4686	-32	9.3
450	4961	-34	9.3
475	5237	-36	9.3

Table 7: Coated Product Effective Stress

COATED GRAPHITE TENSILE TEST RESULTS
VALUES FOR 0.008 INCH SILICON CARBIDE COATING

Sample 2 Side 1

Load (lbs)	Stress (psi)	E (E6 psi)	Poisson (in/in)
25	3619	39	0.16
50	6352	38	0.15
75	9990	38	0.16
100	12639	37	0.15
125	16097	36	0.16
150	19858	29	0.12
175	23578	27	0.13
200	26370	26	0.12
225	26956	19	0.08
250	27358	17	0.08

Sample 2 Side 2

Load (lbs)	Stress (psi)	E (E6 psi)	Poisson (in/in)
25	3294	29	0.16
50	6935	28	0.14
75	11873	27	0.12
100	14736	25	0.12
125	18478	24	0.15
150	20952	22	0.12
175	23758	16	0.09
200	27110	15	0.09
225	26992	15	0.08
250	28236	13	0.07

Table 9: 0.008 Inch Coating Test Results

COATED GRAPHITE TENSILE TEST RESULTS
VALUES FOR 0.008 INCH SILICON CARBIDE COATING

Sample 3 Side 1

Load (lbs)	Stress (psi)	E (E6 psi)	Poisson (in/in)
25	4521	29	0.16
50	8945	28	0.14
75	13614	27	0.12
100	18668	25	0.12
125	25117	24	0.15
150	28112	16	0.07
175	30171	15	0.08
200	30374	14	0.07
225	30608	14	0.06

Sample 3 Side 2

Load (lbs)	Stress (psi)	E (E6 psi)	Poisson (in/in)
25	4854	32	0.15
50	9831	33	0.16
75	17408	32	0.14
100	15825	30	0.12
125	21963	26	0.12
150	27000	19	0.10
175	28804	15	0.09
200	29679	18	0.07
225	27258	18	0.08

Table 9: 0.008 Inch Coating Test Results

COATED GRAPHITE TENSILE TEST RESULTS
VALUES FOR 0.016 INCH SILICON CARBIDE COATING

Sample 2 Side 1

Load (lbs)	Stress (psi)	E (E6 psi)	Poisson (in/in)
25	1351	50	0.06
50	2738	45	0.10
75	4190	37	0.08
100	5618	37	0.09
125	7043	36	0.10
150	8467	36	0.10
175	9882	35	0.10
200	11311	35	0.10
225	12685	35	0.10
250	14142	34	0.10
275	15561	34	0.10
300	16940	34	0.11
325	18396	33	0.10
350	19829	34	0.10
375	21249	33	0.10
400	22623	33	0.10

Sample 2 Side 2

Load (lbs)	Stress (psi)	E (E6 psi)	Poisson (in/in)
25	1369	39	0.11
50	2738	45	0.12
75	4162	41	0.14
100	5569	42	0.13
125	6974	42	0.13
150	8380	42	0.13
175	9730	41	0.13
200	11104	42	0.13
225	12510	42	0.13
250	13916	42	0.13
275	15285	43	0.13
300	16654	43	0.13
325	18055	43	0.13
350	19465	43	0.13
375	20871	43	0.13
400	22231	43	0.13

Table 10: 0.016 Inch Coating Test Results

COATED GRAPHITE TENSILE TEST RESULTS
 VALUES FOR 0.016 INCH SILICON CARBIDE COATING

Sample 3 Side 1

Load (lbs)	Stress (psi)	E (E6 psi)	Poisson (in/in)
25	1382	38	0.11
50	2784	46	0.12
75	4176	44	0.15
100	5573	46	0.16
125	6970	46	0.17
150	8366	47	0.16
175	9767	46	0.15
200	11136	45	0.15
225	12533	46	0.15
250	13916	45	0.15
275	15308	45	0.15
300	16704	45	0.14
325	18092	45	0.14
350	19502	44	0.14
375	20871	44	0.14
400	22259	44	0.14
425	23655	44	0.14
450	25038	44	0.14
475	26426	44	0.14

Table 10: 0.016 Inch Coating Test Results

COATED GRAPHITE TENSILE TEST RESULTS
VALUES FOR 0.016 INCH SILICON CARBIDE COATING

Sample 3 Side 2

Load (lbs)	Stress (psi)	E (E6 psi)	Poisson (in/in)
25	1369	30	0.13
50	2719	34	0.12
75	4097	35	0.10
100	5462	36	0.11
125	6799	36	0.10
150	8191	36	0.10
175	9532	36	0.10
200	10915	36	0.10
225	12266	36	0.10
250	13653	36	0.10
275	15004	36	0.10
300	16354	37	0.10
325	17723	37	0.10
350	19092	37	0.10
375	20457	37	0.10
400	21835	37	0.10
425	23204	37	0.10
450	24573	37	0.10
475	25951	37	0.10

Table 10: 0.016 Inch Coating Test Results

VITA

BARTON CRAIG THOMPSON

Candidate for the Degree of

Master of Science

Thesis: STRESS EVALUATION AND DESIGN METHODOLOGY FOR
PRODUCTS WITH PROTECTIVE COATINGS

Major Field: Mechanical Engineering

Biographical:

Personal Data: Born Hays, Kansas, December 6, 1961;
son of Norman C. and Benice F. Thompson.

Education: Recieved Bachelor of Science degree from
Kansas State University, with a major in
Mechanical Engineering, in December 1985.

Professional Organizations: American Society of
Mechanical Engineers, "Engineer in Training"
certified January 1985.

Professional Experience: Design Engineer, Great
Bend Manufacturing Company, Great Bend, Kansas,
June 1977 through September 1981.

STRESS EVALUATION AND DESIGN METHODOLOGY
FOR PRODUCTS WITH PROTECTIVE COATINGS

by

BARTON CRAIG THOMPSON

B.S., Kansas State University, 1985

AN ABSTRACT OF A MASTER'S THESIS

submitted in partial fulfillment of the
requirements for the degree

MASTER OF SCIENCE

College of Engineering

KANSAS STATE UNIVERSITY
Manhattan, Kansas

1987

ABSTRACT

A criterion for failure of components with thin coatings is needed for accurate design. From the laws of elasticity, and following the ASTM standards for tensile testing of brittle materials, the material properties of the graphite substrate were determined. The values for the material properties corresponded with the ranges supplied by the manufacturer.

The ASTM test was repeated for the specimen with 0.008 inch and 0.016 inch chemically vapor deposited silicon carbide coatings. Premature failure and a sharp change in Young's Modulus of Elasticity were noticed for the 0.008 inch coating thickness. These samples broke at the gage section. The 0.016 inch coating samples continued a linear Young's Modulus to fracture as read at the center section, but broke at the root.

Elasticity equations and boundary conditions were used to derive a method to separate the stresses in

the substrate from those in the coating. An analogy was derived from compound cylinder equations showing the load sharing between the two components. From the separated stresses, the material properties of the silicon carbide coating could be determined.

As a check for the approximation developed, a finite element approximation was executed. The results of the two methods agreed confirming the validity of the use of the failure criterion as a design tool.

