

**/A PROTOTYPICAL (SCHOOL) DESIGN STRATEGY FOR SOIL-
CEMENT CONSTRUCTION IN AFGHANISTAN/**

by
CENK YOLDAS

B.Arch., Uludag University, Turkey, 2001

A THESIS

submitted in partial fulfillment of the
requirements for the degree

MASTER OF ARCHITECTURE

Department of Architecture
College of Planning and Design

KANSAS STATE UNIVERSITY
Manhattan, Kansas

2004

Approved by:



Major Professor
Donald Watts

LD
2668
T4
ARCH
2004
465
C.2

ABSTRACT

Contemporary design and construction methods, when integrated with lessons of traditional vernacular architecture, can lead to a refined, regional, ecological and economical system of building construction. This thesis seeks alternative design prototypes for contemporary compressed soil-cement brick construction suitable for Afghanistan where the climate is arid and the building resources are limited. The purpose of the thesis is to explore the integration of earth and renewable, available, building materials into alternative prototypical spatial enclosures for school structures. The thesis utilizes a design methodology that includes analysis of pertinent literature, identification of essential design requirements, alternative design concept generation, and design refinements based upon design critiques. Although there is an inability of building these prototypes full scale, computer modeling will be utilized to evaluate structural performance. The thesis should provide a valuable source of information for parties seeking advanced appropriate building construction strategies for Afghanistan.

TABLE OF CONTENTS

| | |
|--|-------------|
| TABLE OF CONTENTS..... | I |
| LIST OF FIGURES..... | IV |
| SOURCE OF FIGURES..... | VIII |
| ACKNOWLEDGMENTS..... | X |
| 1 INTRODUCTION..... | 1 |
| 1.1 SIGNIFICANCE OF THE PROBLEM..... | 2 |
| 1.2 AIMS AND OBJECTIVES..... | 5 |
| 1.3 METHODOLOGY..... | 7 |
| 2 LITERATURE REVIEW OF EARTH CONSTRUCTION..... | 11 |
| 2.1 SUSTAINABILITY..... | 11 |
| 2.2 EARTHEN ARCHITECTURE..... | 14 |
| 2.2.1 Traditional Earthen Architectural Methods..... | 15 |
| 2.2.2 Contemporary Earthen Architectural Methods..... | 17 |
| 3 UNDERSTANDING TRADITIONAL EARTHEN AFGHAN ARCHITECTURE.. | 22 |
| 3.1 CURRENT CONDITION OF AFGHANISTAN..... | 22 |
| 3.2 A PROFILE OF PHYSICAL AND CULTURAL CHARACTERISTICS..... | 23 |
| 3.3 VERNACULAR AFGHAN ARCHITECTURE..... | 24 |
| 4 DESIGN PHILOSOPHY..... | 29 |
| 4.1 Design Logic..... | 29 |
| 4.2 Critical Regionalism..... | 31 |
| 5 COMPRESSED SOIL CEMENT BLOCK AND ITS PREPARATION..... | 34 |
| 5.1. COMPRESSED AND SOIL CEMENT BLOCK..... | 34 |
| 5.2. SOIL..... | 35 |
| 5.2.1. Definition and Classification of Soil..... | 35 |
| 5.2.2. Suitable Soil identification for construction..... | 37 |
| 5.3. STABILIZATION AND COMPRESSED SOIL-CEMENT BLOCK MAKING..... | 39 |
| 5.3.1. Stabilization..... | 39 |
| 5.3.2. Ingredients..... | 40 |
| 5.3.3. Soil-Cement making Process..... | 42 |
| 6 THE PRELIMINARY ARCHITECTURAL DESIGN..... | 48 |
| 6.1. THE PROTOTYPICAL DESIGN AND DESIGN MORPHOLOGY..... | 48 |
| 6.2. DESIGN CONCEPT..... | 51 |
| 6.3. PASSIVE SOLAR DESIGN..... | 53 |

| | | |
|----------|--|------------|
| 6.4. | ELEMENTS OF THE CONSTRUCTION..... | 57 |
| 6.5. | SPATIAL DESIGN..... | 59 |
| 6.5.1. | Single Cell Primary Space..... | 59 |
| 6.5.2. | Single Unit and Alternative Unit Proposals..... | 67 |
| 6.5.3. | Double Units and Alternative Unit Proposals..... | 84 |
| 6.5.4. | Master Plan of the School..... | 88 |
| 7 | STRUCTURAL ANALYSIS AND ARCHITECTURAL DESIGN | |
| | REFINEMENT..... | 92 |
| 7.1. | UNDERSTANDING RISA 3-D SOFTWARE..... | 92 |
| 7.2. | STUDYING RISA 3-D AND GEOMETRY OF THE DESIGN..... | 93 |
| 7.3. | DRAWING THE STRUCTURAL MODEL..... | 94 |
| 7.3.1. | <i>Drawing the Dome</i> | 95 |
| 7.3.2. | <i>Drawing the Walls</i> | 98 |
| 7.4. | ANALYZING THE LOADS..... | 101 |
| 7.4.1. | <i>Dead Load Analysis</i> | 102 |
| 7.4.2. | <i>Snow Load Analysis</i> | 104 |
| 7.4.3. | <i>Wind Load Analysis</i> | 105 |
| 7.4.4. | <i>Earthquake Load</i> | 106 |
| 7.5. | CONCLUSION..... | 108 |
| 8 | CONCLUSIONS..... | 118 |
| 8.1 | DESIGN..... | 118 |
| 8.2 | STRUCTURAL..... | 119 |
| 8.3 | MATERIAL..... | 120 |
| | BIBLIOGRAPHY..... | 122 |
| | APPENDIX DOCUMENTATION OF THE DESIGN PROCESS..... | 127 |

List of Figures

| | | |
|-----------|--|----|
| Figure 1 | Distribution of the world population in 1999..... | 3 |
| Figure 2 | World distribution of earthen architecture..... | 3 |
| Figure 3 | Research Diagram..... | 9 |
| Figure 4 | Adobe brick construction..... | 15 |
| Figure 5 | Rammed earth house construction by Rick Joy..... | 16 |
| Figure 6 | Wattle and Daub construction..... | 17 |
| Figure 7 | Cob construction..... | 17 |
| Figure 8 | <i>Stranglehm</i> type of construction..... | 18 |
| Figure 9 | Super Adobe..... | 19 |
| Figure 10 | Compressed stabilized soil block construction..... | 20 |
| Figure 11 | Traditional Afghan vaulting method..... | 25 |
| Figure 12 | <i>Qawwal</i> | 26 |
| Figure 13 | <i>Qala</i> | 26 |
| Figure 14 | <i>Taba Khana</i> | 26 |
| Figure 15 | Gravel..... | 35 |
| Figure 16 | Sand..... | 36 |
| Figure 17 | Silt..... | 36 |
| Figure 18 | Clay..... | 37 |
| Figure 19 | Sieving & pulverizing..... | 42 |
| Figure 20 | Mixing..... | 43 |
| Figure 21 | Cinva-Ram..... | 45 |
| Figure 22 | Dynamically compacted mould..... | 45 |

| | | |
|-----------|--|----|
| Figure 23 | Statically Compacted Mould..... | 45 |
| Figure 24 | Curing & stacking..... | 46 |
| Figure 25 | A morphology of alternative cellular clustering..... | 50 |
| Figure 26 | Winter solar gain..... | 54 |
| Figure 27 | Passive and active heating..... | 55 |
| Figure 28 | Passive cooling..... | 56 |
| Figure 29 | Special brick for rainspout..... | 57 |
| Figure 30 | Single cell rendered perspective..... | 61 |
| Figure 31 | Single cell furnished plan..... | 62 |
| Figure 32 | Single cell structural plan..... | 62 |
| Figure 33 | Single cell dimensional plan..... | 63 |
| Figure 34 | Single cell roof plan..... | 63 |
| Figure 35 | Single cell A-A section..... | 64 |
| Figure 36 | Single cell B-B section..... | 64 |
| Figure 37 | Single cell south elevation..... | 65 |
| Figure 38 | Single cell west elevation..... | 65 |
| Figure 39 | Single cell north elevation..... | 66 |
| Figure 40 | Single cell east elevation..... | 66 |
| Figure 41 | Alternative outside spaces..... | 68 |
| Figure 42 | Single unit furnished plan..... | 70 |
| Figure 43 | Single unit structural plan..... | 71 |
| Figure 44 | Single unit dimensional plan..... | 72 |
| Figure 45 | Single unit roof plan..... | 73 |

| | | |
|-----------|--|----|
| Figure 46 | Single unit schematic section..... | 74 |
| Figure 47 | Single unit C-C section..... | 74 |
| Figure 48 | Single unit A-A section..... | 75 |
| Figure 49 | Single unit B-B section..... | 75 |
| Figure 50 | Single unit south elevation..... | 76 |
| Figure 51 | Single unit east elevation..... | 76 |
| Figure 52 | Single unit west elevation..... | 77 |
| Figure 53 | Single unit north elevation..... | 77 |
| Figure 54 | Single unit dimensional south elevation..... | 78 |
| Figure 55 | Single unit dimensional east elevation..... | 78 |
| Figure 56 | Single unit dimensional west elevation..... | 79 |
| Figure 57 | Single unit dimensional north elevation..... | 79 |
| Figure 58 | System Detail..... | 80 |
| Figure 59 | Single unit rendered section A-A..... | 81 |
| Figure 60 | Single unit rendered section C-C..... | 81 |
| Figure 61 | Single unit rendered perspective..... | 82 |
| Figure 62 | Mosque Plan..... | 83 |
| Figure 63 | House plan..... | 84 |
| Figure 64 | Double unit school plan..... | 85 |
| Figure 65 | Double classroom school unit shaded perspective..... | 86 |
| Figure 66 | Administrative unit plan..... | 87 |
| Figure 67 | Restroom units plan..... | 87 |
| Figure 68 | Four unit school plan..... | 88 |

| | | |
|-----------|---|-----|
| Figure 69 | Three unit school plan..... | 89 |
| Figure 70 | Five unit school plan..... | 90 |
| Figure 71 | Shallow vault, previously designed model..... | 93 |
| Figure 72 | Steeper vault..... | 94 |
| Figure 73 | Shape generation tool..... | 95 |
| Figure 74 | Circular arc generator..... | 95 |
| Figure 75 | Half of a semi-circle..... | 96 |
| Figure 76 | 15° rotated half of a semi-circle..... | 96 |
| Figure 77 | Wire frame plated arc..... | 97 |
| Figure 78 | 80% rendered plated arc..... | 97 |
| Figure 79 | Complete dome with 80% rendered..... | 98 |
| Figure 80 | Typical layout of a wall..... | 98 |
| Figure 81 | Walss of the model..... | 99 |
| Figure 82 | Walls of the model divided into plates..... | 99 |
| Figure 83 | Wire frame of the walls..... | 99 |
| Figure 84 | 80% rendered walls..... | 100 |
| Figure 85 | Rigid links between the dome and the walls..... | 100 |
| Figure 86 | Completed model, 80% rendered..... | 101 |
| Figure 87 | 1828 five story rammed earth building in Weilburg, Germany..... | 103 |
| Figure 88 | Shibam, Wadi Hadhramaut, Yemen..... | 103 |
| Figure 89 | March maximum snow depth-inches in Afghanistan..... | 104 |
| Figure 90 | Cq for Dome Shapes and Cq for walls..... | 105 |
| Figure 91 | Wind load according to the shape of the dome..... | 106 |

Figure 92 Case study models: proportion of height to breadth of the dome.....109

Figure 93 Traditional mud brick structural analysis.....111

Figure 94 Compressed soil cement block structural analysis.....114

Source of Figures

- Figure 1 <http://www.pbs.org/wgbh/nova/worldbalance/numb-nf.html>
- Figure 2 <http://www.terracruda.com/images/terra-worldmap.gif>
- Figure 4 Detheir, J. 1983
- Figure 5 Joy, R. 2002
- Figure 6 <http://www.wealddown.co.uk/winkhurst-reconstruction-reerection.htm>
- Figure 7 <http://www.ecodesign.co.uk/research.html>
- Figure 8 Minke, G. 2000
- Figure 9 <http://www.knoton.com/den/HS/ebag.html>
- Figure 10 Author, Kansas University Broadcasting Hall
- Figure 11 Szabo, A. & Barfield, T.J. 1991
- Figure 12 Kazimee, A. B., & McQuillan, J. 2002
- Figure 13 Kazimee, A. B., & McQuillan, J. 2002
- Figure 14 Hallet, S.I & Samizay, R. 1980
- Figure 15 <http://www.mjausson.com/2000/img/17Dec00/gravel.jpg>
- Figure 16
<http://207.54.124.170/pics/Small%20Versions%20of%20these%20pictures/sand-sm2.jpg>
- Figure 17 <http://generalhorticulture.tamu.edu/h202/labs/lab7/mineral-articles/html>
- Figure 18 Ibid.
- Figure 19
<http://www.unhabitat.org/programmes/housingpolicy/documents/Compressed.pdf>
- Figure 20 Ibid.
- Figure 21 Ibid.

Figure 22 Author

Figure 23 Ibid.

Figure 24

<http://www.unhabitat.org/programmes/housingpolicy/documents/Compressed.pdf>

Figure 25- 86 Author

Figure 87 <http://www.bigwalls.net/johnm/earth.pdf>

Figure 88 <http://www.worldsapart.org/yemen.htm>

Figure 89 <http://www.ncdc.noaa.gov/oa/climate/research/afghan/afghan2.html>

Figure 90- 94 Author

ACKNOWLEDGEMENTS

I would like to thank a number of people who have helped me make it possible to complete my master's degree. I would like to thank them in chronological order.

I would like to thank Prof. Neslihan Dostoglu and James Jones for giving me the opportunity to come to Kansas State University and to work for a master's degree that I have always wanted. I am also grateful first to my family and then to my relatives for their great encouragement and financial support.

Thank you to Prof. Donald Watts. I am so lucky to have a wonderful, helpful, and patient major professor. His guidance and ability to lead has helped me finish with a satisfactory result in my heart. It is also great to have somebody that you can talk to, laugh with and share other things besides work. It has been a very enjoyable and educational experience. I am also thankful to Prof. Dragoslav Simic for his teachings and help. He is a great person, full of knowledge and fun to work with. I am also fortunate to have somebody like Prof. Fayez Huseini. His critiques have improved the design and brought up useful design questions. His presence has always been positive for me.

I thank all the professors that I know and work with. All of them are outstanding teachers.

Finally, I am so happy to have a wife like Chrissy. Her editing, support and patience has been helpful throughout the process of this thesis.

1 Introduction

This chapter discusses, the significance of the problem, the aims and objectives, methodology used, research diagram, and the research hypotheses.

Earth is one of the oldest and the finest types of construction material. There is no continent on the world that is absent of earthen architecture. For the developing countries; it is the most efficient and economical resource to house the majority of people, and for the developed countries; it is the most economically sustainable and environmental material. There is no doubt that earth material has many important advantages over other construction materials, yet it is still weak against weather conditions and earthquakes. Its inadequacy against durability challenges researchers and people who use this material to find ways of improving it.

Earth construction methods are fundamentally empirical and predicated upon the accumulated wisdom of trial and error. In contrast, this thesis is based upon mathematical simulation that in turn requires mathematical data as to the performance of the materials and construction methods. A major challenge of this research was in seeking acceptable performance specifications for a truly loose and organic building material, mud brick.¹

It is important to seek ways of combining this accumulated knowledge with the use of the new materials and ways of construction techniques into earthen architecture so that the quality of living spaces and the importance of earthen architecture would become stronger.

1.1 Significance of the Problem

Earth has been a primary construction material since the first known civilizations. Throughout history, architecture has been shaped around the natural resources close at hand: wood, stone, unbaked sun dried mud bricks. Only in recent times was man capable of producing different materials, such as steel, aluminum and plastic. Use of these new materials and capitalist propaganda of spending and consuming more, lead the industries to increase their production and investments. Increased production and investments have been demanding more energy resources to produce more products. On the other hand, the new innovations of artificial climate making such as air-conditioning and heating devices also help to increase energy demand. The use of new materials and tools caused the loss of craftsmanship and traditional building techniques, which are results of accumulated experiences.

The development of new materials and construction techniques within the last 150 years seemed to reduce the interest in using earth as a construction material in modern parts of the world; however the pre-dominance of earth as a primary construction material has never decreased. Despite the increasing global economy, the cost of living is so high and poverty is such a dominant factor in many countries that earthen architecture is still in use throughout the world. The maps in figures 1 and 2 show the distribution of world population and the use of earthen architecture around the world. The figures clearly show the continuous use of earth as a construction material.

Approximately 30% of the world's population lives in earth-made buildings and 50% of the population in developing countries.² The majority of the world's rural population and at least 20% of urban and suburban population live in earth-made buildings.³

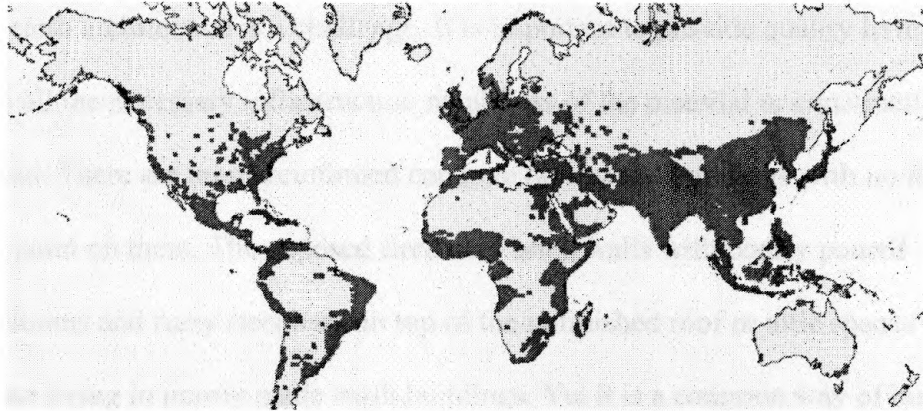

FIG.1 DISTRIBUTION OF THE WORLD POPULATION IN 1999

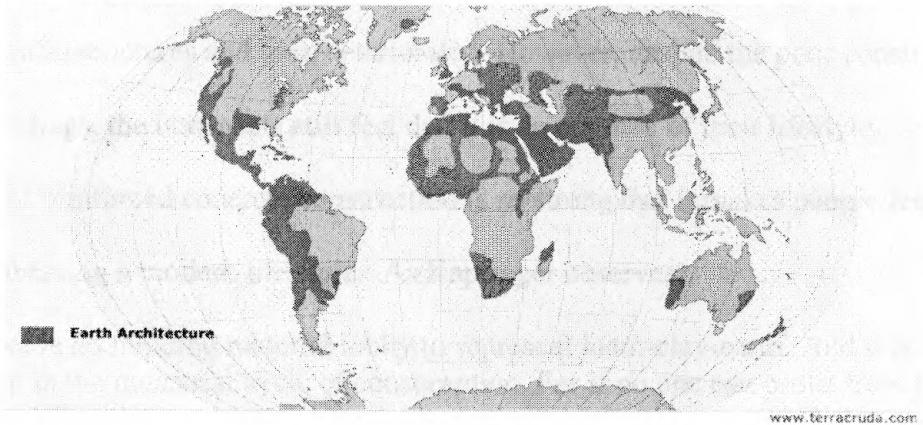

FIG.2 WORLD DISTRIBUTION OF EARTHEN ARCHITECTURE

Even though the numbers indicate the high use of earth as a building material, the majority of the users are poor people. Given the increased number of poor population and the demand on energy and environmental issues, there have been increased interests in earth construction. The new interest in earthen architecture within the developed countries has brought new techniques and applications of earthen architecture as well as new research in ways of developing these techniques.

As Easton says:

...in these days of ecological concern as we seek simpler, more appropriate solutions to the environmental challenges that face ourselves and our children, the word "earth"-and all that connotes-has become once more a central concept for ourselves.⁴

Promoting earth architecture is a challenge. It is important to provide quality living spaces with all the necessary infrastructure regardless of the material or construction methods used. There are many reinforced concrete homes and buildings with no finish coatings or paint on them. The exposed fired clay brick walls with poorly poured concrete columns and rusty steel bars on top of the unfinished roof or attic spaces are no different than living in poorly made earth buildings. Yet it is a common way of building in the outskirts of urban areas in developing countries. Such buildings often have inadequate infrastructures and look deteriorated. However, despite the poor construction of these buildings, the occupants still feel that it is an upgrade of their lifestyle.

Promotion of reinforced concrete construction is so strong that it makes people feel that they are embracing a modern life style. As Kapfinger observes:

There is no building material lobby to represent loam-clay-earth. And it is a weak point in the industrial cycle of consumption. For if no one can profit from this material, which is generally available on the construction site itself, the one essential factor the capitalist forces that drive building is lacking regardless of how many other positive attributes this material has to offer.⁵

Based upon this premise, this thesis seeks a construction method that would promote earth architecture as well as cement manufacturing and limited amount of steel usage. The production and use of compressed stabilized soil bricks (CSSB) should ideally mediate between tradition and modernity. The practical use of earthen architecture with

all its advantages would become more desirable and durable with the added modern improvements.

It is also possible to use the stabilization and compaction idea with the rammed earth construction technique, but this technique would require using wood or steel formwork that would not be available for a certain cost and site. In places such as Afghanistan where the majority of buildings are made out of earth material and the source of wood and steel is very limited, the use of CSSB could become a very important construction technique. It would be much cheaper and easier to carry having one simple mechanical compression tool that would be shared within the community and could be used for a long time rather than different sizes of wood or steel formwork, just used for a specific design.

In developing countries, like Afghanistan, , use of CSSB can be proven to be a major construction material, that can be used to meet the building demand with a contemporary, sustainable, energy-efficient design and more importantly peculiar to the region.

1.2 Aims and Objectives

This thesis is intended to study the globally renowned methods of site related mechanically hand pressed soil-cement bricks into a prototypical school design project with the help of computer aided software products and also traditional design tools. It is the intention of this thesis to seek ways of synthesizing traditional social-cultural and formal-spatial attributes with modern materials and construction tools. Also the thesis intends to provide practical information on technical issues for easy understanding.

The objectives of this thesis are fourfold. First, to discuss the sustainable earthen architecture for the region of Afghanistan: second to integrate globally renowned mechanically hand pressed stabilized soil-cement brick: third to provide a prototypical design based on this brick making system, and finally to integrate computer based structural analysis and drawing into architectural and structural design.

The scope covered under each of the above objectives are summarized below:

1. *Discussion of thesis related subjects:*
 - a) Emphasize the concept of critical regionalism in the development of a theoretical base for the design concept.
 - b) Outline the critically important issues of construction in third world countries and the importance of sustainability to support the use of earth construction.
 - c) Understand earthen architecture to be able to compare and demonstrate the importance of cement stabilized soil-brick (CSSB).
 - d) Study Afghanistan by which the design can respond realistically to the subjects of the thesis.
2. *Compressed Stabilized Soil-Cement:*
 - a) Acquire adequate information to understand the basics and the types of the soil.
 - b) Provide easy ways of field investigation methods to be able to identify the proper soil for CSSB construction.

- c) Outline the importance of the ingredients of the CSSB in order to produce better bricks.
 - d) Describe the process of CSSB making to provide information to reach better brick results.
3. *Prototypical Design Process:*
- a) Discuss the idea of prototype and its application to the design in order to clarify the architectural concept.
 - b) Provide the architectural drawings of the design to explain the idea and show the solutions that is proposed for a prototypical school.
4. *Structural Modeling:*
- a) Study the structural issues related to the design and prepare a procedure for the computer modeling.
 - b) Draw the model with the structural software to adapt the design for calculations.
 - c) Computer model comparisons of traditional earthen architecture and CSSB to support the design ideas.

The achievement of the above objectives is evaluated in the concluding parts of this thesis.

1.3 Methodology

The method that is conducted for this thesis is shaped around a design studio method, which has nine phases.

1. *The first phase* is analyzing the problem and its context. This is basically reviewing and summarizing the primary sources of theory, supportive literature and databases for overall importance relative to each other.
2. *The second phase* is the beginning of the design process and the starting point of the studio. Identification of essential design requirements and alternative design generations is created in this phase.
3. *The third phase* is the presentation of these alternative concept generations. The presentation is for the committee members. The result is documented and leads to the next phase.
4. *The fourth phase* is the selection of the most promising concepts according to the third phase.
5. *The fifth phase* is the preliminary design development of the selected concept. According to this concept, structural computer aided modeling is done as well as outlining thermal and day-lighting issues.
6. *The sixth phase* is the presentation of the refined design according to the structural modeling and the outcomes of the structural modeling.
7. *The seventh phase* is the development of the final architectural design with issues of construction detailing.
8. *The eighth phase* is a final design presentation and final review to the committee.
9. *The ninth phase* is the final design revision and documentation of the results.

The hypotheses of this research is: Contemporary design and construction methods and economically available modern and regional materials can lead to a refined, regional,

ecological and economical system of building construction that builds upon lessons of traditional vernacular architecture and yields much improved performance.

The research diagram in figure 3 illustrates the relationships among the variables in this study. We can consider regional architecture, Afghanistan, and characteristics of the material as independent variables for the earthen architecture and design concept, climate and site issues, and construction as dependent variables for the prototypical design.

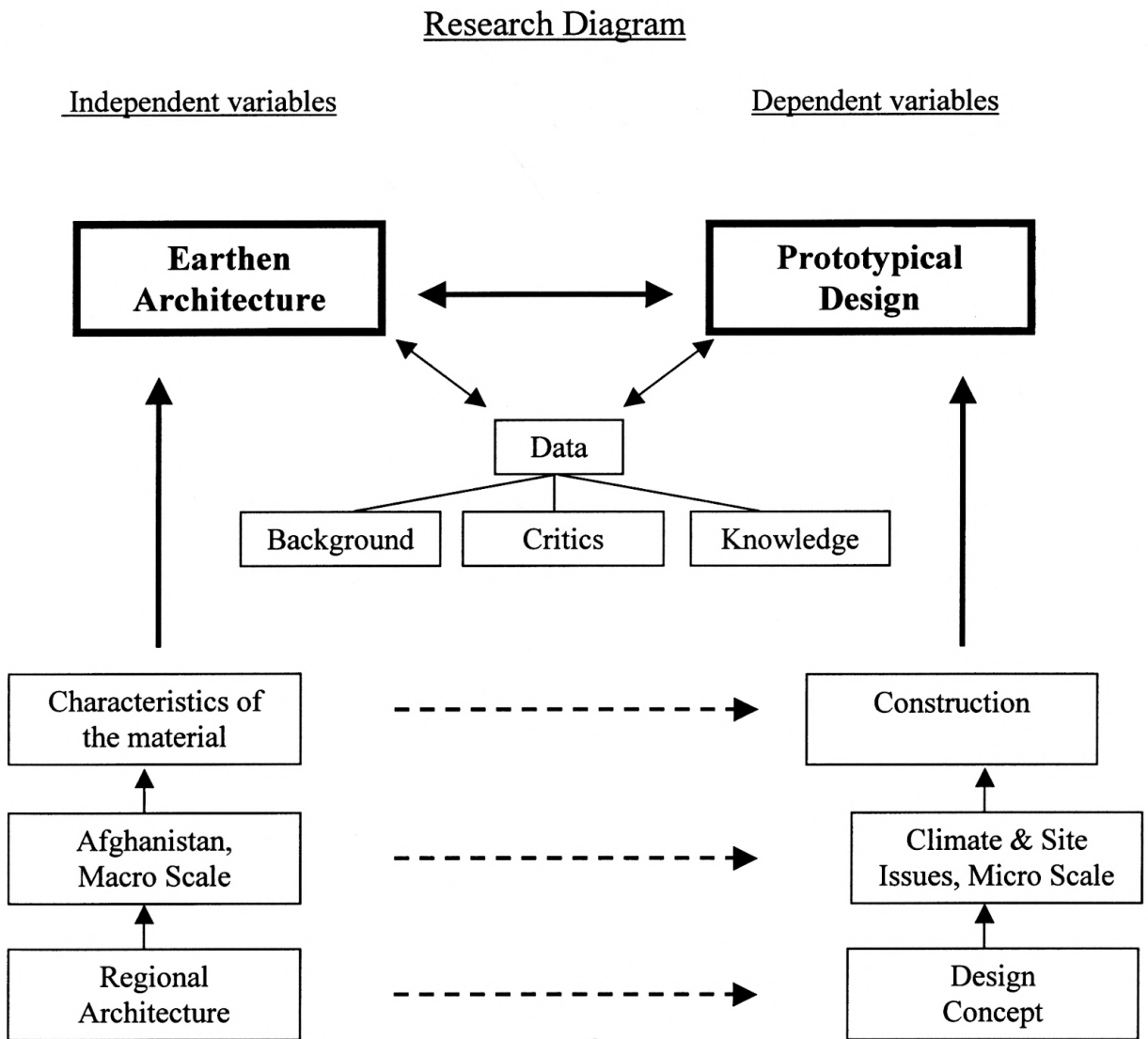

FIG.3 RESEARCH DIAGRAM

References:

¹ Watts, D.J & Yoldas, C. (2005). "Re-Conceiving Afghan Cellular Architecture for the Reconstruction of Rural Schools." Traditional Dwellings and Settlements Working Paper Series: vol. 168. Center for Environmental Design Research, University of California, Berkeley, Forthcoming.

² Houben, H., & Guillaud, H. (1994) *Earth Construction: A Comprehensive Guide*. Southampton Row, London: Intermediate Technology Publications.

³ Ibid.

⁴ Easton, D. (1996). *The Rammed Earth House*. Vermont: Chelsea Green Publishing Company. p.ix.

⁵ Kapfinger, O. (2001). *Rammed Earth*. Basel Switzerland; Birkhäuser- Publishers for Architecture. p. 13

2 Literature Review of Earth Construction

Having stated the need for earthen architecture in developing countries, especially in Afghanistan, this chapter of the thesis provides the background to the subject of interest, earthen architecture, and the supportive subject of sustainability.

2.1 Sustainability

With the limited resources of the world's environment, the study of sustainability and energy consumption has become an issue in a constantly developing world. Today 40% of the energy that we use worldwide is for the construction and repair of the built environment.¹ Therefore, alternative materials and construction methods have become more energy efficient and environmental friendly to structure the built environment. The use of solar and wind power and increased interest in passive solar and sustainable design are the conscious approaches of developed countries. Yet there is still more to do. Besides looking for new construction methods and materials it is also important to know how to better design materials and construction methods that we already have in order to build in a more sustainable and energy conscious manner.

Paschich and Zimmerman² apply sustainable architecture to four critical areas:

- The choice of material;
- Energy consumed during production of materials, construction, and long-term use (life cycle of energy cost);
- Minimizing pollution and solid waste generation, again during production, construction, and long-term use;
- The longevity of materials and design to minimize maintenance and replacement cost.

It can be seen that the choice of construction material has a big impact on sustainable architecture. The interest in sustainability and energy conscious design brought two terms to literature directly associated with the material. These are embodied energy and operating energy.

Embodied Energy: is the energy consumed by all of the processes associated with the production of the building, from the acquisition of natural resources to product delivery. This includes the mining and manufacturing of materials and equipment, the transportation of the materials and the administrative functions. Embodied energy is a significant component of lifecycle of a building.³

This is the description of embodied energy applied to the construction area. It can also be applied directly to the material itself. The direct and indirect energy to produce a certain material is also called embodied energy. In this case, the extraction of natural resources, transportation to the factory, processing the material, transporting to the construction site, and placing in the structure would be the direct energy. The energy used to produce materials and equipment to manufacture a certain material can be counted as indirect energy.

Operating Energy: a building's operation energy involves the total amount of energy the building consumes in its lifetime, including energy supplied by utilities (or locally generated power and hot water) in order to maintain it. Factors such as building size, site orientation, engineering, and quality of insulation influence operation energy.⁴

Maintenance is a very important part of operating energy, which indicates the importance of the aftermath of construction.

It can be understood that it is really important to focus the material, which is used in construction, in terms of sustainability. Most of the locally available materials, such

as stone, earth, and wood, are labor-intensive rather than energy-intensive and can reduce the life-cycle cost of a building. Therefore longevity is also an important part of sustainability. The materials used should be durable, easy to maintain, and suited to the location and climate. It is especially important to maintain the existence of the building in the poor countries in order to benefit long-term. Today, within the United States alone, at current building rates it will take less than 40 years to rebuild half as many buildings as exist in the country.⁵

One of the other sustainable approaches is use of passive solar techniques in design. We can improve building energy performance in heating, cooling, and lighting areas to conserve more energy. We have to consider the orientation of the building and rotation of the sun in terms of solar radiation and gain. Here the material choice becomes important in terms of absorbing, transforming and storing the heat. At this point thermal mass of material should be considered for a sustainable design.

Thermal mass is a material that has the ability to hold heat or coolness.⁶ Some of the materials, which are nontoxic, can hold heat and coolness. These are masonry materials such as brick, concrete, earth, water, and stucco.

Cooling and lighting can also be achieved with the rotation of the sun, orientation of the building, and some various devices and techniques. Natural day lighting design eliminates use of energy and also provides a healthier and pleasant environment.

Shading, thermal insulation, earth-air cooling are some efficient sustainable ways to

protect a building from unwanted heat gains.

A responsible design should consider these variables for good sustainable, environmental, sensitive living conditions. When we look at all the items and issues discussed above, earth material and earthen construction plays significant role within the appropriate materials and construction methods.

2.2 Earthen Architecture

Earthen architecture is a technique that reflects the material, culture, socioeconomic infrastructure, sustainability, self-adequacy, authenticity, and skills available in a particular region. Even though earthen architecture is a composition of one main material: it can differ from one region to another and from one technique to another.

Earth as a material comes from different compositions, which can be vigorously processed. There are several important traditional earth construction methods and various contemporary techniques that improve the way of construction with earth. Loam is the scientific name for clay soil and it is the core of the construction. Its application process gives different names to the earth construction. These construction methods can be categorized under two names: traditional construction methods and contemporary construction methods.

2.2.1 Traditional Earthen Construction Methods

There are several important traditional earthen construction methods. These are adobe (sun dried mud brick) Rammed earth, wattle and daub, and cob.

Adobe: It is an Arabic and Berber word and describes bricks that are molded wet and cast small enough to shrink without cracking.⁷ This is the most common traditional earth building method. The bricks are made with earth, straw (optional) and water, and usually dried in the sun. The bricks require mud plaster for protection against weather conditions and frequent maintenance of the plaster is a must to expand the life of the building. Dry and hot or cold climates are appropriate for this technique. Selection of soil types, molding and a drying process are important phases for making adobe bricks. It is preferable to have large bricks for strength and easy construction purposes.

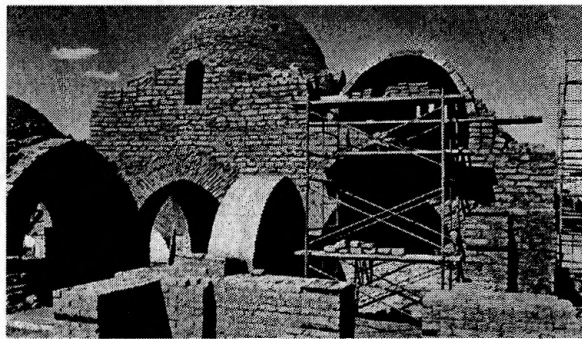

FIG. 4 ADOBE BRICK CONSTRUCTION

Rammed Earth: Loam that is crumbly, relatively rich in sand content, and of natural soil humidity is poured in layers into formwork and compacted by means of ramming.⁸ Rammed earth is a monolithic construction method and provides the advantages of longer life. It is a preferable earth construction method in a humid climate because it does not require a curing process. Its compaction provides higher

strength and durability compared to adobe bricks. The formwork is the heart of the construction and they are usually made out of wood. Steel molds are common in contemporary rammed earth construction. Traditionally an iron hammer is used to compact the wall, but contemporary methods use hydraulic tools to compact and remove the air lumps.

There are also some new tools that are applied to rammed earth construction techniques to compress the earth more effectively. Steel formwork is used for better surface results. Additives, to improve durability and strength are another improvement of rammed earth construction technique. This new improved rammed earth construction is also one of the widely used contemporary rammed earth techniques.

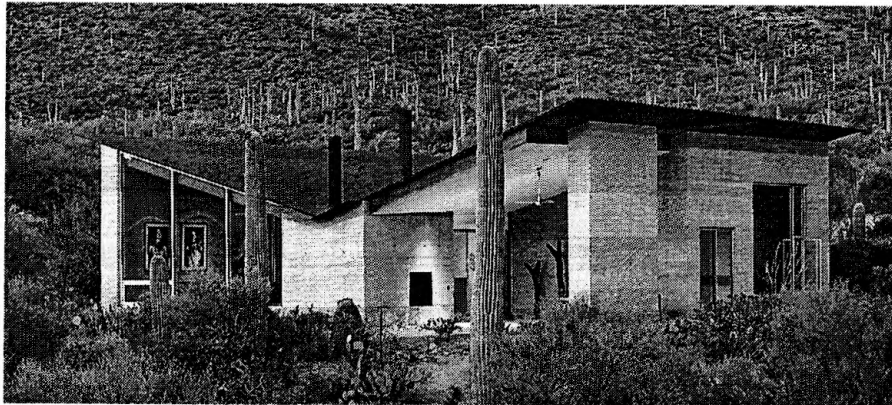

FIG. 5 RAMMED EARTH CONSTRUCTED HOUSE BY RICK JOY

Cob: The word cob comes from the old English meaning lump or rounded mass.⁹ Cob is a combination of sand and clay with straw and water added. Sub-soil can be used with an even distribution of clay mixed with plant fibers. Clay soils used in cob construction provide protection against weather conditions. The most critical design consideration for cob buildings is protection from soaking. Cob walls can absorb

large amounts of water. If they stay wet for long time, it can weaken the straw and that weakens the wall.

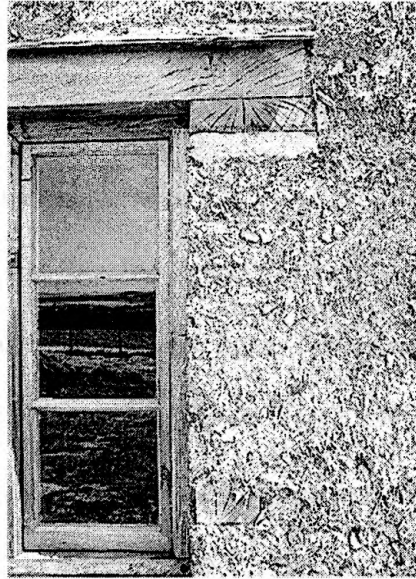

FIG. 7 COB CONSTRUCTION

Wattle and Daub: Wattle is a woven framework of twigs and daub is a mud covering applied over framework.¹⁰ It is an easy and simple method of construction. Its section depends on the wooden part of the construction. This causes the section of the wall to not be thick enough to supply thermal mass. The disadvantage of this system is that it requires a lot of maintenances due to the cracks. Cracks are the main reasons of erosions and insects that live in the walls.¹¹

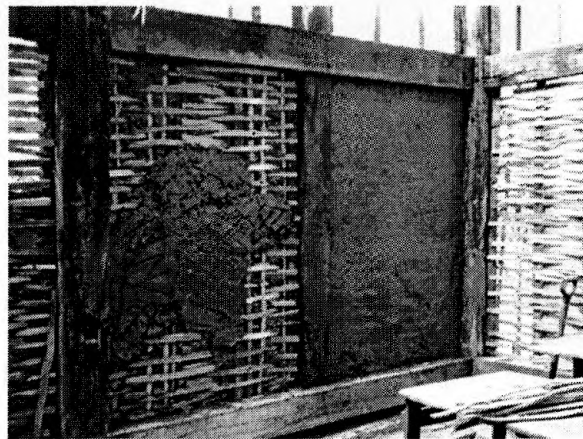

FIG. 6 WATTLE AND DAUB CONSTRUCTION

2.2.2 Contemporary Earth Construction Methods

The important contemporary earth construction methods are super adobe or earthbags, *geltaftan*, *stranglehm*, and compressed stabilized soil blocks.

Stranglehm: A wet loam technique was developed by the University of Kassel, Germany in 1982. In order to develop wet loams an extrusion tool was designed by the university. The wet loams can be as long as 2 meters but the experiments indicate 0.7 meters loams shows no shrinkage. Higher clay content, approximately 15%, is important for this technique. The loams are placed into a frame structure. Each portion of the wall should be filled, due to the shrinkage gaps, with a mixture of lime, gypsum, sand, or same material once the walls are dry. Walls of loam can be easily shaped for sculpturing purposes.

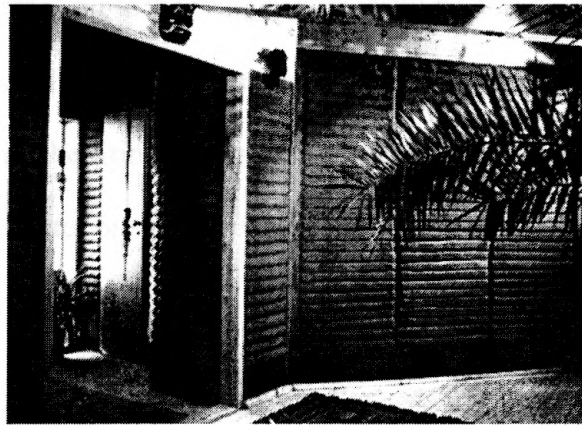

FIG. 8 STRANGLEHM TYPE OF CONSTRUCTION

Super Adobe or Earthbags: This is a technique that utilizes textile or plastic soil filled sacks. It is inexpensive, requires few skills, faster than other earth building methods, and provides flexible form variations. This technique is also proposed for lunar construction. It uses almost any type of soil. Organic soils should probably be

avoided because long-term damage might occur on the bags. This technique is also not widely used.

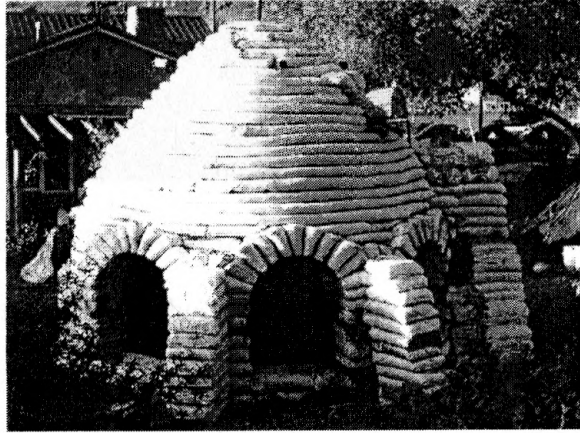

FIG. 9 SUPER ADOBE

Geltaftan: This is a typical adobe construction fired from the inside to outside and glazed for better weather protection and higher stability. It is an idea that comes from brick kilns. In this case the structure works as a kiln and a significant amount of energy is saved during the firing due to the extra bricks, pots, jars and tiles are baked in the structure to sell later on. This technique is still not common and stays as an experiment.

Compressed Stabilized Soil Block (Bricks): This is one of the widely accepted contemporary earth construction techniques, which utilizes a compression tool and a chemical additive to improve characteristics of the blocks. Application of compression increases the strength and decreases the voids inside the bricks, which makes bricks more durable against weather conditions. The research and testing of this technique are still ongoing.



FIG. 10 COMPRESSED STABILIZED SOIL BLOCK CONSTRUCTION

Most of these earth construction methods have similar design guidelines. Earth as a wall material is strong enough to stand but it is vulnerable to weather, which is one of the important concerns in its use. Water should be kept away from all parts of the building by careful drainage design. At this point the compressed stabilized soil blocks (CSSB) have a very important advantage compared to other types of earth construction. The bricks themselves can resist weather conditions and require no plastering. If the bricks are used for roofing it is wise to put an extra layer of plaster for longer life. Figure 10 is an illustration of CSSB construction nearly 60 years old. The building has very short eaves, yet the bricks are in very good condition. Lawrence, Kansas where the building is located, is a place with a mild climate. It is rainy during the spring and autumn and has snow during the winter. The precipitation of Lawrence is approximately 36-40 inch annually.¹² This standing example goes unnoticed along with other conventional fired bricks and has no extra protective coating on it.

References:

¹ Elizabeth, L. & Adams, C. (ed.) (2000). *Alternative Construction: Contemporary Natural Building Methods*. New York: John Wiley & Sons.

² Panschich, E, & Zimmerman, J. (2001). *Mainstreaming sustainable Architecture: Casa de Paja: A Demonstration*. Corrales, New Mexico: High Desert Press. p.4.

³ Milne, G. & Reardon, C. *Embodied Energy* from <http://www.greenhouse.gov.au/yourhome/>

⁴ Imhoff, D. (2001). *Building with Vision: Optimizing and Finding Alternatives to Wood*. Healdsburg, California: Watershed Media. p. 19.

⁵ Elizabeth, L. & Adams, C. (ed.) (2000)

⁶ Ibid.

⁷ Easton, D. (1996). *The Rammed Earth House*. Vermont:Chelsea Green Publishing Company.

⁸ Kapfinger, O. (2001). *Rammed Earth*. Basel Switzerland; Birkhäuser- Publishers for Architecture.

⁹ <http://www.zedland.co.uk/backearth/whatcob.htm>

¹⁰ Easton, D. (1996).

¹¹ Minke, G, 2001. *Construction Manual for Earthquake-Resistant Houses Built of Earth*. University of Kassel Germany.)

¹² http://equineestates.com/library/United_States/kansas.htm

3 Understanding Traditional Earthen Afghan Architecture

It is important to understand vernacular Afghan architecture and the current situation of the country along with the country's characteristic features in order to design for Afghan people.

3.1 Current Condition of Afghanistan

Afghanistan is a nation in crisis for the last 25 years due to conflicts and wars. Millions of Afghans were forced to leave their land and become refugees in neighboring countries or inside Afghanistan. Approximately 30% of the houses were destroyed during the wars¹ and many of them were damaged. Currently 2 million refugees² returned to their homeland and the population is expected to increase by 14 million over the next decade.³ With all these facts, the demand for re-construction of housing and other buildings is urgent. Afghanistan is still a very poor country and its resources are limited. With the problem of economy, construction demand and lack of skilled masons and labors, the cost of building increased significantly over the last decades.⁴ It is important to use the resources of Afghanistan to re-build the country instead of relying heavily on imports. Currently, various countries are donating aid and reconstruction of the country is undertaken by means of modern ways of construction with the importing of modern material. It is important to provide technologies and methods of construction to sustain local human and material resources rather than outside sources since the country has limited financial resources. At this point earthen architecture assumes an important role in re-building the country while still being a common way of construction.

3.2 A Profile of Physical and Cultural Characteristics

Afghanistan is surrounded by Iran, China, Pakistan, Kashmir, Turkmenistan, Uzbekistan, and Tajikistan. It is dominated by large mountain ranges from highest, 7600 meters, in the northeast to lowest, 3000 meters, in the southwest. These mountains, the Hindu Kush, occupy three-quarters of the country and they are geologically of recent origin and still growing. This causes severe earthquakes. Afghanistan is a semi-arid country with a continental climate of hot summers and cold winters. It is estimated that only 21 % of the country's land is productive.⁵ Farming is one of the major incomes. Afghanistan has many distinct ethnic groups, the majority of them being Pashtuns. The other two major groups are Tajiks and Uzbeks. Dari and Pashtu are the two official languages.

Afghanistan has a long history of civilizations. It was one of the important routes for the historical Silk Road and the location of many wars. This diversity of historical experience has resulted in a variety of architectural traditions and imported ideas. These rich interactions of cultures resulted an Afghan vernacular architecture. As Barfield & Szabo have indicated:

“The variety of building types and their richly varied use of materials display a creation of form, articulation of space, modulation of light, and shade, control of thermal environment, and richness of surfaces that is at once simple yet eloquent. Here, as with many other examples of indigenous architecture, we see the results of centuries, perhaps millennia, of revolution and refinement that produce an indigenous balance between people and their environment.”⁶

3.3 Vernacular Afghan Architecture

Rich cultural interactions, harsh geographical conditions, limited resources, people, and environmental issues are composed of today's Afghan vernacular Architecture.

Traditional Afghan architecture is based on most available materials, earth, stone and wood. Although modern construction methods can be seen in the cities, they are not economical and abundant. There are some brick kilns that provide fired-bricks usually for more urban settlers. Most common buildings utilize mud walls as wide as one meter. Mud construction is replaced by wood and stone material if available and abundant. The vernacular Afghan building techniques work well with today's passive solar design concepts.

There are several different earth construction methods in Afghanistan. Two common types are mass clay walls, *pakhsa* and sun-dried mud bricks.⁷ The foundations are made out of stones with mud mortar. If stone is not available flattened and compressed soil is used. Vaulted roofs and flats roofs are the most common types of roofing systems.⁸ The flat roofs are made out of poplar trees covered with lath and reeds and on top of them various layers of mud clay and straw plasters are applied. This type of roofing system is commonly used in the central eastern, southeastern and northeastern regions of Afghanistan. The flat roofs also used for laying out fruits and vegetables to dry or for sleeping purposes during the summer time. The vaulted roofs can be found in the north, northwestern, west, and southwestern parts of the country. These roof types are made out of sun-dried mud bricks and covered with plaster that contains straw for erosion protection. Burnt brick are not economical and rarely used. Domes are constructed

without a formwork using a technique that is a result of experience. A mason starts building inclined arches (squinches or pendentives) from the corners up to a point where these arches can connect together. These arches form a circular form of brick layers in the case of a square plan and form angled arches in the case of a rectangular plan (fig. 11). The top of the domes can be left open for ventilation purposes using a wind catcher or topped with glass for lighting. Domes and vaults are also covered with mud plaster containing straw.

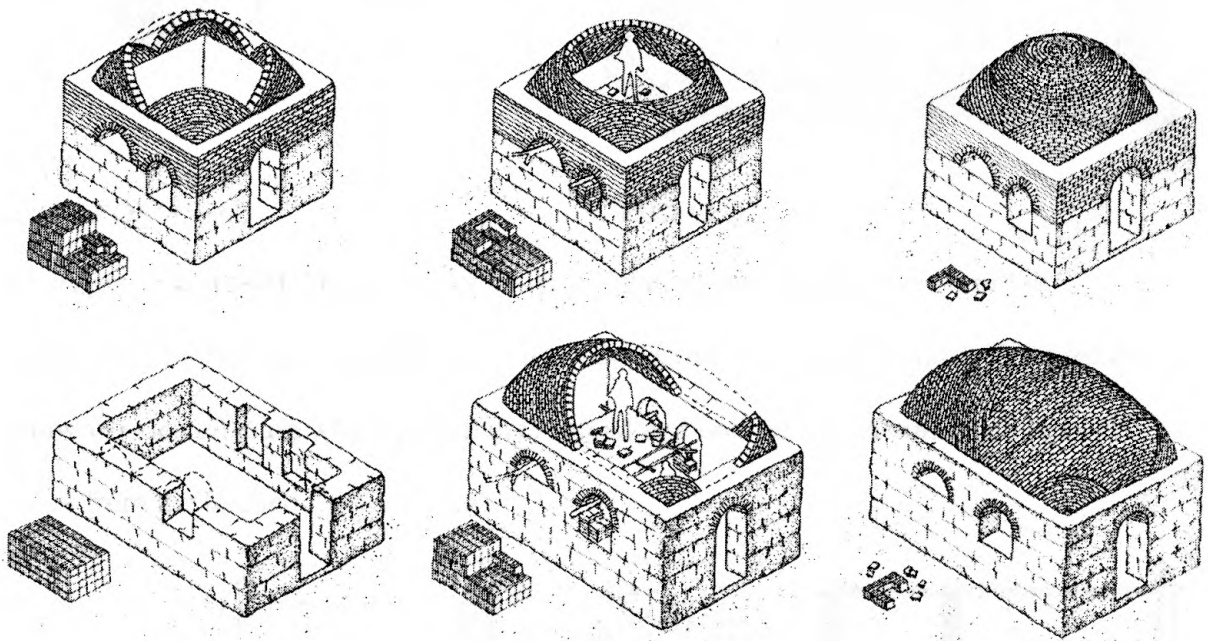

FIG. 11 TRADITIONAL AFGHAN VAULTING METHOD

Throughout the country one can see various types of buildings, such as black and cotton tents, *yurts*, huts, *Qawwals* (transition from tent to hut)(fig. 12), *Qalas* (the fortress housing group) (fig. 13), courtyard houses, and mountain or hillside type of buildings. There is a common security feature in most of the buildings. Protection from outside

threats is an important role where there is a group of people. This can be seen in the architecture of *qawwal* or *qala*, or the villages that are located on the hilltops, and houses with courtyards.

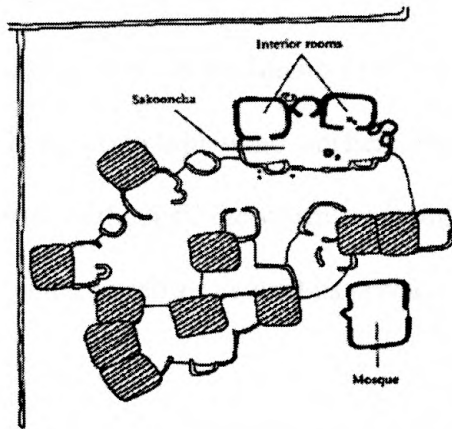

FIG. 12 QAWWAL

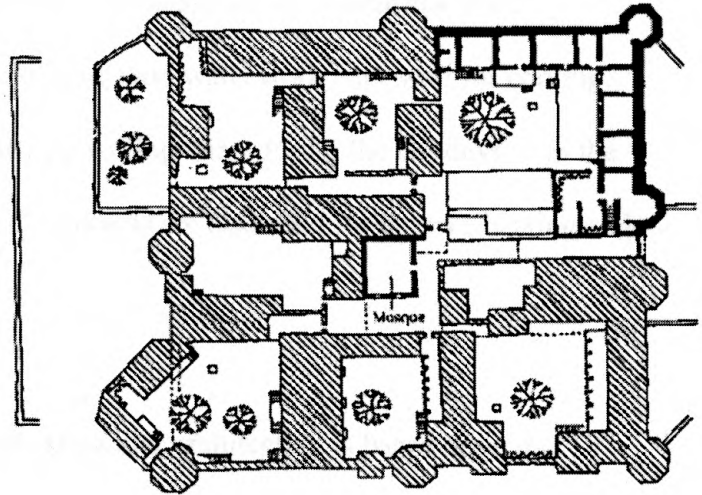

FIG. 13 QALA

There are also similar techniques for cooking, heating and cooling in most of the buildings. The heating is usually done with *taba khana* (fig. 14) or *sandali*. The *sandali* is a low wooden table on which a blanket is spread and uses a fire container with left over ashes from the kitchen.⁹

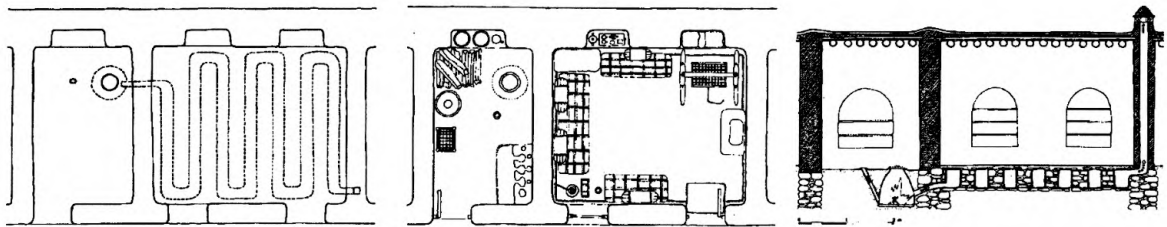

FIG. 14 TABA KHANA

A *taba khana* is a design solution for heating. A *tandor*, a type of kiln or oven used to cook bread, is the heat source for a *taba khana*. The heat given off from the *tandor* (from the kitchen) is circulated through under-floor heating tunnels. These heating tunnels are

constructed as stone trenches covered with stone slabs. They retain the heat and keep the floor warm. When cooking is done then the fire will burn slowly and keep the next room warm for a longer time.¹⁰ The source of fuel is wood, hay, or cow dung. Besides this type of heating, the thick mud walls provide a good insulation due to their low heat conductivity. Wind catchers (*badgir*) and thick mud walls work very well for cooling. These scoop type wind catchers bring the prevailing wind during the hot days in to the space and expell the warm air at night. Courtyards are also used for passive heating and cooling purposes as well as privacy.

The selection of the materials in Afghan vernacular architecture is based upon its availability, necessity, strength, and passive energy design values.¹¹ These vernacular values can easily work with modern technology, and living conditions can be improved without changing the traditions and cultures of Afghanistan.

References:

¹ U.S. Department of State Fact Sheet January 10, 2003. Humanitarian Success Stories in Afghanistan. From <http://www.state.gov/p/sa/rls/fs/16729.htm>

² Ibid.

³ United Nations Human Settlements Programme, in focus Afghanistan, from <http://www.unchsh.org/afghanistan/>

⁴ Scherrer, O., 1990. Afghan Refugee Housing. *Mimar*, 34, 43-50: Architecture in Development, London, Concept Media Ltd.

⁵ Hallet, S. I. & Samizay, R. (1980). *Traditional Architecture of Afghanistan*. Garland Publishing, Inc. New York, USA.

⁶ Szabo, A. & Barfield, T.J., (1991). *Afghanistan: An Indigenous Domestic Architecture*. Austin, Texas: University of Texas Press, p.1.

⁷ Ibid. p. 112.

⁸ Scherrer, O. (1990). p. 46

⁹ Azizi, M. (1980). "A Preliminary Study of Traditional Building Crafts in Kabul, Afghanistan" Royal Danish Academy of Fine Arts, Department of Building Restoration, p.18.

¹⁰ Hallet, S.I & Samizay, R. (1980). p. 141.

¹¹ Ibid. p. 195.

4 Design Philosophy

The underlying philosophy of the design of this thesis is the common logic approach towards architecture, which I relate to think the idea of Critical Regionalism recent in architectural theory. This chapter will first talk about the opinion of the author about common logic and then its parallel with the idea of Critical Regionalism in architecture. The author expresses his own thoughts and opinions and accepts all the criticism on the subject of common logic.

4.1 Common Logic

In this thesis, the idea of common logic is the widely accepted decision, result, consequence, action, set of rules, etc. For example; some people may like dark environments to live in and do everything in that light intensity, but let us say if you are reading you need light in order to read, so the user is the reader not that individual, and a reader needs light for his action and his health. It is important to work with the client and respond to his/her needs, but it is also the responsibility of an architect to explain the common logic for the welfare of the individual or the society. The room can be designed very dark but the user should be informed with the consequences of this request. Or you may have a million dollars as your wealth and need a house, so the expected common logic for you is to build a house and save as much as you can to sustain and increase your wealth for a long time rather than finish it up with having luxurious materials, unused spaces, useless details. and face a financial crisis.

It would be irrational to build with cement or soil blocks a nine stories high bearing wall type structure in New York City where the price of a land is so high and the availability of high rise construction techniques is well developed and abundant. On the other hand it would also be irrational to build skyscrapers in Kabul, Afghanistan. So some of the important concepts that affect the common logic are the conditions, circumstances, needs, and availabilities of the specific situation.

Common logic is mostly open for changes. It may be logical to build with a certain type of material, which is cheap and abundant now, till some other material; cheaper and more abundant may be replaced with the older one. This would happen gradually, not drastically, as long as it is not provided all at once for a proper price. Besides these common logics, there are certain logics that can't be changed, such as two times two equals four. These types of logics are mostly scientific or historical based knowledge.

Architecture is a result of a set of common logics. There are many things that affect the outcome of architectural identity of a specific area. The environmental issues, tradition, culture, the subject of the structure, economy, population, materials, and leadership are several of them. Any change in one of these logics does not mean an identity loss. It means an improvement in architecture and identity. For instance a group of migrating people might come to an area of abundant trees and agricultural land and decide to settle there and instead of using their mobile structures, they build houses to live in for their own benefit. So when a permanent change happens it happens as a whole. Anything that is not accepted by the common logic will not survive. In this case the mobile structure,

which was once the accepted one now becomes the unaccepted. Or in another example, a dictator might take over a leadership and change the architecture according to his own desires. This would continue as long as he and his leadership is successful and survives. Once they are gone, the common logic would persuade its own architecture back towards where it was or at least reassess what it desires.

This kind of example can also be seen in the case of building without considering the sustainable and environmental issues. Before utilizing technological improvements, buildings are designed to utilize the use of sun, wind, and light for the purpose of heating, cooling and lighting, which are the source of health and comfort. This type of design logic was probably one of the universally accepted design principles. With the technological improvements and new energy sources this basic common logic is replaced with different types of designs that do not utilize the basic principles. With the fact of reduction in energy resources and increasing environmental problems, more people are coming back to the common logic of utilizing wind, sun and light in their design using modern technologies.

These new changes shaped new ideas and definitions in architecture, such as sustainability, green design, new modernism, and critical regionalism. The most promising idea that works with the idea of common logic and for me is Critical Regionalism.

4.2 Critical Regionalism

There are many opinions and sources about critical regionalism. Critical regionalism has emerged as an equilibrium between modernist architecture, universalization and vernacular architecture, more traditional and cultural approach. William Curtis points out the importance of finding the right balance between local, national and international; “The aim is to unravel the layers, to see how indigenous archetypes have been transformed by invading forms, and to in turn see how foreign imports have been adapted to the cultural soil. The present task is to keep the process moving: to find the right balance between local, national and international.”¹ Critical Regionalism seeks an architectural synthesis between the culture (local) and universal. It combines the new technology in favor of improving the basis of rooted common logics by not changing it.

In the favor of vernacular architecture, Critical Regionalism opposes the image-oriented architecture, romantic regionalism, and favors spatial and experiential architecture that promotes use of local materials, craftsmanship and responsiveness to the light and climate.² It also accepts the topography as it is and resists the homogenization of the built environment and International Style of a flat, cleared site.³

In the favor of modern architecture, Critical regionalism accepts the reinterpretations of outside cultural principles and technologies, as Berg indicates that architects should incorporate modern building requirements and current construction methods and decides on past principles that are still appropriate and valid for today’s reality.⁴ Also inventors of the term “Critical Regionalism”, architect Alexander Tzonis and historian Liane

Lefaivre, points out the importance of a critical reevaluation of local culture and employing modernist strategies.⁵

Architecture should improve the conditions of living and building by respecting time-proven indigenous solutions that can still be used in the favor of the majority and translated into modern technologies. It should also avoid obsolescence solutions that are picturesque and useless.

References:

¹ Curtis, William. 1986. Towards an Authentic Regionalism. In MIMAR 19: Architecture in Development. Singapore: Concept Media Ltd, pp. 25.

² Frampton, K. (1983). Prospects for Critical Regionalism. In Nesbitt, K. (ed). (1996). *Theorizing a New Agenda for Architecture: an Anthology of Architectural Theory 1965-1995*. Princeton Architectural Press, New York, USA, pp. 468.

³ Ibid.

⁴ Beng, T. H. (2001). *Modernizing Appropriations/ Appropriating Modernity*. In A. Tzonis, L Lefaivre & B. Stagno (Eds), *Tropical Architecture: Critical Regionalism in the Age of Globalization* (pp.93-103). New York: Wiley-Academy, pp. 101.

⁵ Tzonis, A. & Lefaivre, L. (1990). Why Critical Regionalism Today?. In Nesbitt, K. (ed). (1996). *Theorizing a New Agenda for Architecture: an Anthology of Architectural Theory 1965-1995*. Princeton Architectural Press, New York, USA, pp. 483

5 Soil and Compressed and Stabilized Soil-Cement Brick

The aim of this chapter is provide adequate knowledge on Compressed Stabilized Soil Bricks (CSSB) and its manufacturing process. This chapter also includes brief but effective information on soil and its characteristics. Anybody who does not have knowledge of any soil will easily recognize the proper soil that needs to be used in the construction of CSSB by the conclusion of this chapter.

5.1 Compressed and Stabilized Soil Block

Soil is a material that has poor resistance against erosion and abrasion, high water absorption, and a low tensile strength.¹ Therefore bricks made out of soil with no extra improvement have most of these disadvantages. Many adobe homes require frequent maintenance to maintain their existence. This results in high maintenance cost throughout the lifespan of the building. However, use of compression and 5% to 10% cement as a stabilizer, strengthens the soil. Even though CSSB manufacturing is more time consuming and labor intensive than traditional earth bricks, its advantages make the brick a much better choice for today's earth construction. CSSB is fireproof material with good thermal storage capacity and is as strong as a burnt brick. Also the mortar used between the bricks is the same material as the CSSB itself. Thus the wall unit is much stronger than a traditional earthen wall. Its attractiveness and finished look is no different than any burnt brick or cement block construction if the CSSB is well prepared. It is a transition between traditional and modern construction methods. CSSB is not just a regular earth brick that contributes to the unskilled labor market, but also cement and Cinva-Ram manufacturing industries benefit from it. CSSB is fairly new compared to traditional earthen architecture.

There are examples of CSSB dating back to the 1940's. The make-up of CSSB involves four categories of ingredients and their relative proportions, the methods of preparing and mixing these proportions, the compaction, and the treatment of the bricks after produced.

5.2 Soil

There are four types of soil classifications: gravel, sand, silt, and clay. They show differences from one another in characteristic ways. Gravel and sand are stable materials while silt and clay are not. The stability, in this regard, is able to sustain its properties in wet conditions. This is an important issue for soil blocks in terms of their life span and strength.

5.2.1 Definition and Classification of Soil

Gravel: Gravel is a small piece of rock (fig. 15). The sizes of gravel ranges between approximately 2mm and 20mm. It forms a stable soil and has mechanical properties that do not change in the presence of water. It is not preferable to use a large amount of gravel as a building material because of its lack of cohesion with other materials.



FIG. 15 GRAVEL

Sand: The size of grains of sand range from approximately 0.06 to 2mm. Sand lacks cohesion when dry, but has a very high degree of internal friction. It displays apparent cohesion when moistened. Sand (fig. 16) is the best ingredient for a good soil-cement brick.

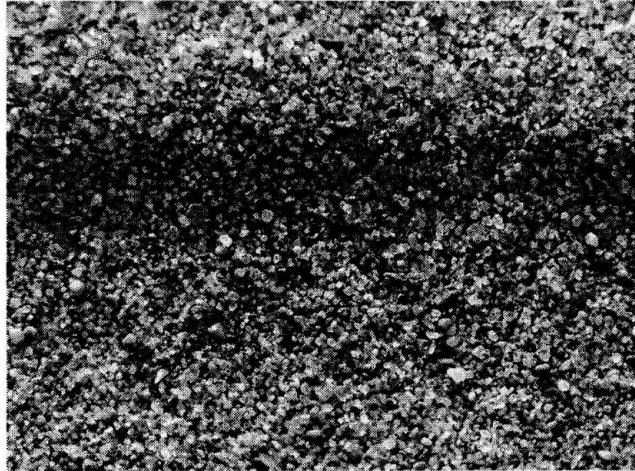

FIG. 16 SAND

Clay: They are the finest particles of the soil (fig. 18). The size of clay is smaller than 0.002mm. Clay acts as a binder for all larger particles in the mixture. Clay is vulnerable to swelling and shrinkage when dry. It has a low resistance to deformation in a moist state, but dries out into very cohesive masses. Clay is difficult to compact when moist.

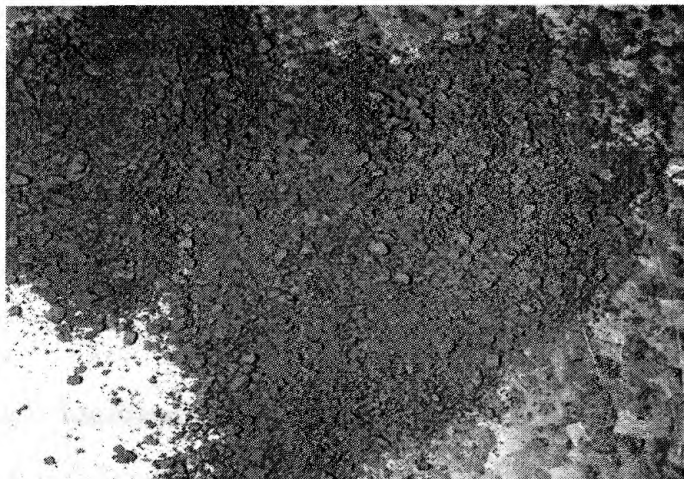

FIG. 18 CLAY

Silt: Silts are fine grains (fig. 17). Their size ranges from 0.002 to 0.06mm. They are unstable in the presence of water. When dry, silt can be easily pulverized between the pressures of a person's fingers. Silt gives the soil stability by increasing its internal friction. Because of their high permeability silty soils are very sensitive to frost. It is subject to small-scale shrinkage and swelling.

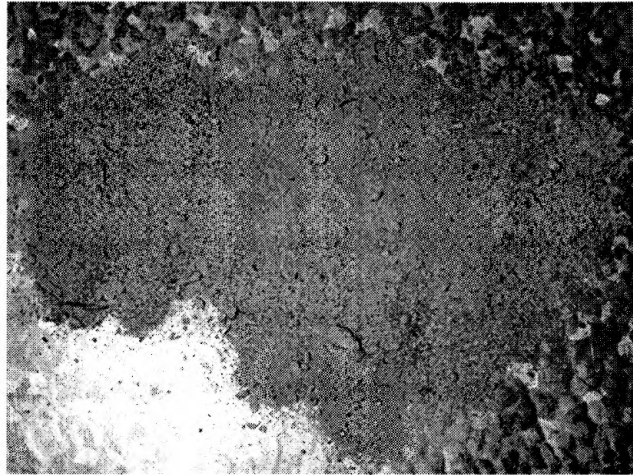

FIG. 17 SILT

Gravel and sand give the material its strength while clay acts as a binder and silt fulfills a less clear intermediate function. A soil with 65-80% sand and 35-20 % clay and silt can be considered suitable for use in brick making.² There are usually organic materials on the surface of the soil. Organic materials are not suitable for brick making and have to be removed. A certain amount of clay provides a good cohesion and plasticity, which is the capacity to change shape without breaking.³ Plasticity is important in order to work effectively with the soil.

5.2.2 Suitable Soil Identification for Construction

Before starting to make soil blocks there has to be a search done for proper soil around the construction site. To look for a convenient specimen, the sample area should be dug from

40-50 cm deep. Usually topsoil contains organic matters, which are not good for soil blocks. Organic soils have a dark color and a more distinct smell than other soils.

There are several ways to identify suitable soil for construction.

1) Visual Examination: Understanding the above given soil classifications would be sufficient enough for visual examination.

2) Testing by Touch: For this test a small amount of soil should be taken into the hand and rubbed. After this it should be moistened and rubbed again. Sand has a rough feeling when it is dry and lacks cohesion. Silt has a rough feel similar to the sand but when moistened it has a medium plasticity. It will be hard to wash off if the soil has a high content of silt. Clay usually occurs in the form of a clod. Wet clay presents an adhesive and plastic state. If the soil is very sticky and very hard to wash off, it has high content of clay in it.⁴

3) Jar Test (Sedimentation): There is a need for a glass jar or bottle to make this test. The bottle should not be less than a half-liter. The jar should be filled with $\frac{1}{4}$ soil and with $\frac{3}{4}$ water and then shaken very harshly and left to settle on a flat surface.⁵ It would be good not to handle the shaken bottle for at least 30-60 minutes to observe the settled layers.

The materials will settle according to their size distribution. The gravel will be at the bottom followed by the sand, silt and clay. The size of the layers indicates the proportions of the materials. This test helps to see if the soil contains equal distribution of

ingredients. It can also help to see if there is too much from one material.

4) Cigar Test: Get a ball of mud without gravel. Start to roll it like a cigar. If it breaks before 5 cm more clay is needed. If it breaks after 15cm there is too much clay in the soil and more sand should be added.⁶

5) Shrinkage Test: Make several specimen compressed earth brick units using different soil samples from different sites. Keep them in a shaded area for three days. If the sample shrinks more than 3-5%, it means more sand is required for proper brick making.⁷

6) Brightness Test: This is a test to check clay content quickly. A mass of moist soil should be cut with a knife. Bright surfaces indicate clay and opaque surfaces indicate silt and sand.⁸

7) Dry Strength Test: This is a test to understand the plasticity of the soil. A 2-3cm ball shaped moistened specimen should be prepared to the consistency of dough and left to dry. Once the sample is ready, it should be crumbled by hand and observed. If the sample crumbles easily it contains inorganic materials, silt, sand, and small amount of clay. If it breaks or pulverizes with considerable pressure it contains sandy-clay, silty-clay, or organic-clay mixture. If it doesn't break or pulverize easily it contains a high amount of clay content.⁹

5.3 Stabilization and Compressed Soil-Cement Brick Making

5.3.1 Stabilization:

There are several issues that can be done to treat the soil for a better strength and texture characteristic. Stabilization of the soil is one of the ways of improving the characteristics of a soil.¹⁰ Soil requires stabilization because the material as found in its natural state is not durable for long-term use in buildings. Cement and compression are one of the most effective methods of stabilizing the soil. One can reduce the volume of the voids and connect the particles together using cement and compaction. This will reduce porosity; help to protect the bricks from water penetration and erosion, which is one of the most important aspects to sustain the strength of the brick via protecting it from water.¹¹ This will also help to reduce swelling and shrinkage percentages as long as production follows the proper procedure. Mechanical strength, dry and wet compressive strength, will also improve with these methods. Research on durability of cement-stabilized earth walls has tested the durability of the material against weather conditions.¹² In this research sandy clay material with different cement content is compressed into 120 mm diameter and 6 cm section of PVC drainage pipes and water by a nozzle at a pressure of 100 kPa after 28 days of curing in a laboratory. A same set of samples are also kept outside and were exposed to natural weather conditions from 15th of October 1998 to 3rd of March 1999 in Sidney Australia. A 516 mm rainfall was measured at that time zone. The results showed that with 7% cement and under 180 minutes of water exposure the specimen in the laboratory had 15 grams of material lost while another specimen with 8% cement content had 4 grams of material lost at 141 minutes exposure time. According to researchers, the test was stopped because no more material was lost. The specimens kept outside had 43

gram lost on 7% cement and 31 gram lost on 8% cement. This research significantly shows the importance of the cement stabilizer for the bricks to resist weather.

5.3.2 Ingredients of Compressed and Stabilized Soil-Cement:

There are three important components in soil-cement blocks. These are the proper amounts of soil, cement, and water.

Soil: A proper soil selection is a must for a good soil-cement block. Identification of the soil must be done around the construction site and classifications must be done according to the information given above. Sandy soils are the best, if available, because they produce the best results when stabilized. Fine particles are hard to interact with cement. Particles smaller than 0.02mm, which are considered to consist of silts and clays, will hinder the cementitious process.¹³ The optimum proportion is 75% sand and 25% silt and clay; the content of the clay should not be less than 10%. If we need to give a range it would be a minimum of 45% sand 55% silt and clay, and a maximum of 80% sand and 20% silt and clay.¹⁴ These are the approximate values, but the main idea is that soils with texture better interact with cement. Bigger size soils more than 20mm should not be used. Once the proper soil area is found, the soil should be taken and left in a dry area to get the moisture out of the soil for further processes.

Cement: The cement is the regular Portland cement, which is widely known. Cement is basically a mixture of lime and clay, which is heated to about 1,500° C, and the resulting clinker has gypsum added and the sum is then ground to very fine powder.¹⁵ Cement particles start to react when water is added to the mixture and form an interlocking

matrix.¹⁶ This helps to improve the strength of the blocks. For a good soil-cement mixture, depending on the soil content, 5-10% cement should be sufficient for a good compressive strength and waterproofing.

Water: The amount of water is an important issue for the mixture. Too dry or wet soil mixture will have less workability, strength, and durability. The water used should be clean, and should not contain salt. Excess water in the mixture will drive cement particles further apart and will cause a loss of strength.¹⁷ The optimum moisture content is important for a good result. Generally 8 to 16% water is a good range to consider in volume.¹⁸

5.3.3 Soil-Cement Making Process:

The production of the soil-cement blocks has impact on the quality of the product, output, and economy of the operation. Also each process of the production affects the compressive strength of the blocks.¹⁹ There are several processes of the production, which are preparation, mixing, compaction, drying, and curing. Each needs to be done carefully in order to get a good output.

Preparation Process: The soil that is convenient for the block making should be located on a hard surface to mix easily (fig. 19). Before mixing, the soil should be pulverized to break up the lumps of soil particles to get a uniform soil content.

The big sizes of the soil, bigger than 20 mm, should be taken using an appropriate size sieve. If there is no availability of a sieve, pieces should be removed by hand as much as possible. Once this is done the soil should be kept in a dry condition so further lumps will

not occur.²⁰

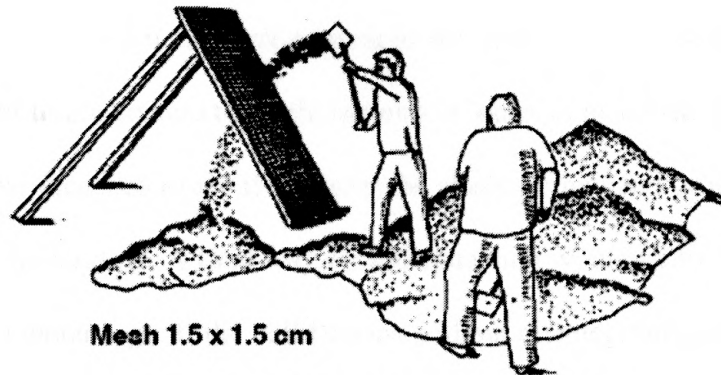

FIG. 19 SIEVING & PULVERIZING

Mixing Process: Mixing is divided into two parts as dry and wet mixing (fig.20).

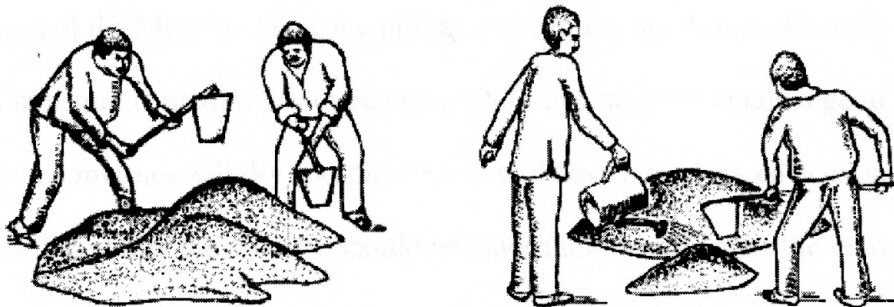

FIG. 20 MIXING

1) Dry Mixing: A tool or tools to carry and measure the soil and the cement should be chosen and used for all mixing purposes. This way it will be easy to specify the proportions. The measured soil should be spread out and leveled as a thin layer no deeper than 10 cm.²¹ The measured amount of cement is added onto the soil uniformly. There should be extra care taken to add the cement evenly all over the soil, but it should not exceed its own proportion. After adding the cement, soil and cement must be mixed uniformly and this should continue until it reaches a uniform color. Mixing can be done with a shovel or something similar that can work like a shovel.

2) Wet Mixing: The dry mixture is layered thin and water should be sprinkled on it uniformly until the optimum moisture content or the maximum unit weight can be obtained. In order to understand the right amount of water to be added, a hand full of mixture should be squeezed to see if it retains the shape of the hand or if it can be pulled apart without disintegrating. A final way of understanding would be by dropping a ball of the soil from one meter high. If the ball flattens without disintegrating when it lands there is more water than there should be. If it disintegrates similar to the original mixture it has the right amount. If it crumples and falls apart easily it needs more water.

Compaction of the Mixture: Once the proper soil-cement mixture is obtained with optimum moisture content it has to be used within two hours to obtain a good result. Otherwise the mixture will dry and the cement will have already been activated chemically. Therefore the mixture should be placed into a mold after the mixture is ready and compressed using the handle of the Cinva-Ram. If too much water and mixture is coming out of the mold during compression it means the mixture has too much water in it and the mixture should be prepared with less water.

There are many types of production equipment to produce the blocks. Most of the best ones require fossil fuel or electricity to operate and they can produce significant amounts of brick daily, but these are expensive to have. Two other ways that are useful and requires no additional operational material rather than human power are the regular wooden or steel mold that uses direct human force via a big hammer which causes dynamic compaction (fig. 22) and a steel mold, which is called Cinva-Ram (fig. 21), with a long steel arm that transforms the human power into more pressure that causes static

compaction (fig. 23). According to Montgomery²², " improved levels of compaction have a significant effect on the compressive strength of the sample and the effectiveness of the cement stabilizer added." The Cinva-Ram can be produced for a small budget and the use of a Cinva-Ram will definitely affect the strength and quality of the blocks. This thesis uses bricks that are made by a Cinva-Ram.

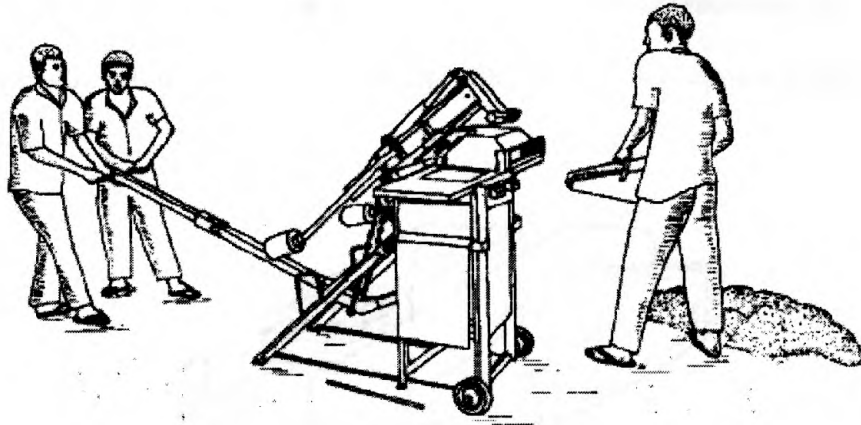

FIG. 21 CINVA-RAM

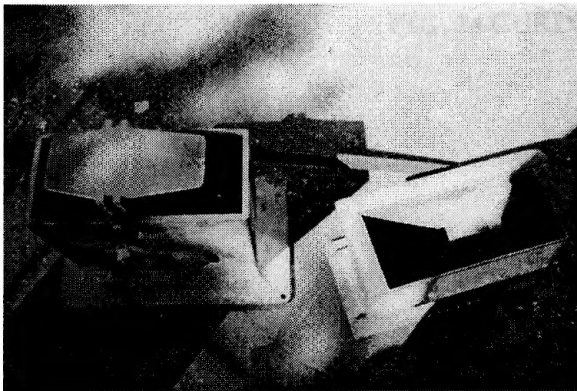

FIG. 22 DYNAMICALLY COMPACTED MOULD

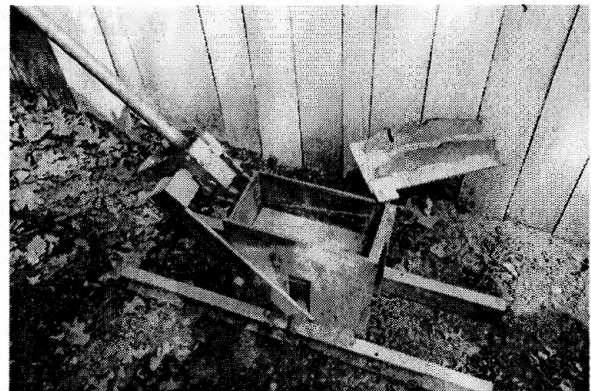

FIG. 23 STATICALLY COMPACTED MOULD

Curing Process: After applying the pressure and taking out the blocks from the mold, blocks must be kept on a flat surface area protected against the sun and the wind (fig. 24). The blocks should be rotated everyday. This will help to get uniformly dried blocks. The

blocks should also be kept in a humid environment for 7 days using a sheet of plastic to cover the top of the blocks.²³ Sometimes watering the bricks is helpful in reducing the percentages of shrinkage. Watering should be by done by sprinkling.

Drying Process: Blocks must be protected from the sun and wind otherwise the compressive strength will be lower than expected. Drying will take approximately 14 days.²⁴

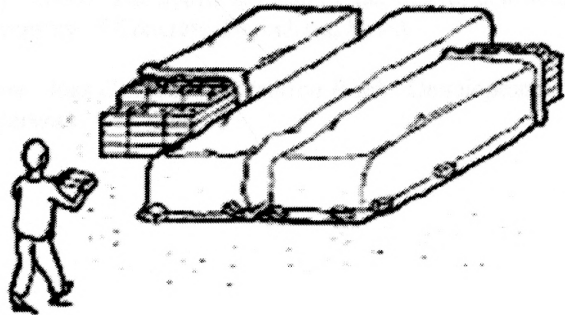

FIG. 24 CURING & STACKING

References:

¹ Kerali, A.G. (2001). *Durability of Compressed and Cement-Stabilized Building Blocks*. Unpublished Doctoral Dissertation, University of Warmick, Warmick, England.

² United Nations. (1964). *Soil-Cement: Its Use in the Building*. Sales No. 64. IV. 6. , United Nations Publications. New York, USA. p. 20.

³ Rigassi, V. (1995). *Compressed Earth Blocks: Manual of Production*. Vol. 1. CRATerre-EAG. Vilefontaine Cedex, France. p. 30.

-
- ⁴ Ibid. 37
- ⁵ U.N., 1964, p.9.
- ⁶ Erdik, M.O. (ed) (1987). *Middle east and Mediterranean regional conference: on Earthen and Low-Strength Masonry Buildings in Seismic Areas*. Middle East Technical University, METU, Ankara. p. 172.
- ⁷ Ibid. 259
- ⁸ UN, 1964, p.12.
- ⁹ Ibid
- ¹⁰ Houben, H., & Guillaud, H. (1994). *Earth Construction: A Comprehensive Guide*. Southampton Row, London: Intermediate Technology Publications. p. 73
- ¹¹ METU, 1987, Basilio, p.491.
- ¹² Heathcore, K.A., & Moor, G.j. (2000). *Durability of Cement Stabilized Earth Walls*. 5th CANMET/ACI International Conference on Durability of Concrete, Barcelona, Spain
- ¹³ Montgomery, D.E. (1998). *How Does Cement Stabilization Work?* Development Technology Unit School of Engineering, University of Warwick, UK. p.18.
- ¹⁴ UN, 1964, p.20.
- ¹⁵ Montgomery, 1998, p.7.
- ¹⁶ Ibid. 10
- ¹⁷ Ibid. 12
- ¹⁸ UN, 1964, p.22.
- ¹⁹ Houben & Guillaud, 1994, p.241.
- ²⁰ Rigassi, 1985, p.44.
- ²¹ UN, 1964, p.23.
- ²² Montgomery, D.E. (2002). *Dynamically Compacted Cement Stabilized Soil Blocks for Low-cost Housing*. University of Warwick, School of Engineering, England. p. 39
- ²³ Rigassi, 1985, p.45.
- ²⁴ Ibid.45

6 The Preliminary Architectural Design

The objective of this chapter is to provide an architectural design solution for a prototypical school building, which is applicable in many regions of the world, but especially in Afghanistan. The chapter follows in order from the idea behind the design, which is the formal and ideal approaches, to the final architectural design. The design has no intention of claiming perfection, but to be a prototype with an optimum solution within the decided set of challenges. Surely any design can be a timeless process if it is not stopped. The architectural draft of the design process is also added as an appendix to show the stages of the design.

6.1 The Prototypical Design and Design Morphology

According to the Webster Dictionary, “prototypical means relating to a prototype and a prototype means a standard or typical example.” Aiming to design a prototype for a broad range of factors such as different topographies, climates, orientations, availability of the materials, different functions, and users, requires an optimum solution. This optimum solution defines the standards of the prototype, which is described in the definition.

Also, according to the Prototype Theory, “categorization is accomplished by the acquisition of a prototypical representation of a category via a form of abstraction process.”¹ If we match the word *standard* from the first definition with the word *category* of this sentence we can approach a prototypical design via a form of abstraction process.

To meet the challenge of designing for an optimum solution there has to be a balance between the design and the standards or categories. Balance is a word that recalls uniformity, stability, equality, proportion, or, a circle, a square, a triangle a physical equilibrium perhaps as described in Webster's Dictionary. I used the form of an abstract idea, a square form, which is one of the perfectly balanced forms, to develop the design in a morphological way.

There are many different balanced shapes but a square, as mentioned above is the best uniform shape that can be used to easily construct a series of soil blocks. Obviously a circle is a uniformly better shape than a square, but the advantages of the square, whether in soil brick construction or in architectural design, is better than a circle. A square is easier to design spatially. It is easy to have openings placed within the walls and has no problem transferring into a dome, which can be seen almost in all Islamic architecture. It is easy for two or more squares to come together and design other forms and also support one another in terms of structural relationships.

From this point of view, a square form is chosen to study the design in a morphological way. The square form is used as a cell that can grow and create different clusters as in an Afghan Qala or fortified clustered layout, which explained in chapter 3. A series of cells (fig. 25) with different but proportional dimensions is studied to identify a best-fit layout. Since the main design program is the classroom, a classroom size square is chosen to be the main cell and the most promising one due to the rest of the design criteria is selected. It can be designed in many different cellular forms by dividing and multiplying this cell.

This single cell is explained in detail in further sections of this chapter. After working with the program of the design the most promising morphology is chosen to develop further architectural improvement.

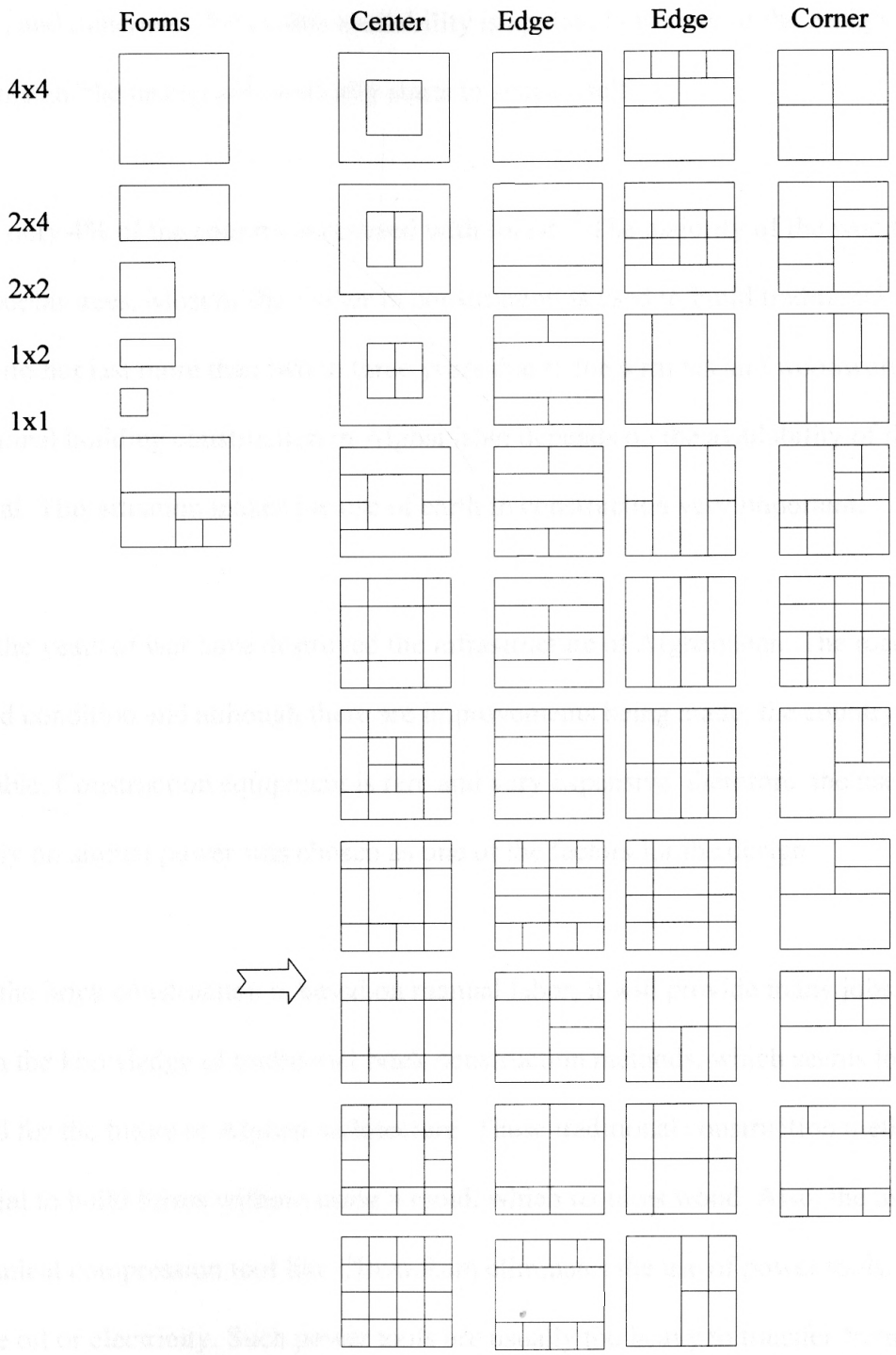

FIG. 25 A MORPHOLOGY OF ALTERNATIVE CELLULAR CLUSTERING

6.2 Design Concept

The concept of the design starts with an emphasis upon availability. Availability is important to poor people with urgent building needs, and having meager technology, money, and materials. When this availability is applied to the site of the design, Afghanistan, the design automatically starts to shape itself.

Today only 4% of the country is covered with forest.² The majority of the wood comes from poplar trees. Most of the timber in construction is used to build traditional flat roofs, which do not last more than two to three years due to the termites and woodworms.³ Traditional building construction in Afghanistan depends on the availability of the material. This situation makes the use of earth in construction very important.

Also, the years of war have destroyed the infrastructure of Afghanistan. The roads are not in good condition and although there are improvements being made, the country is still not stable. Construction equipment is rare and very expensive, therefore, the use of carts that rely on animal power was chosen as one of the factors for the design.

Since the brick construction is based on manual labor, it will provide many jobs and sustain the knowledge of traditional brick construction methods, which seems to be needed for the future of Afghan architecture. These traditional construction methods are essential to build forms without using a mold, which requires wood. Also, the use of mechanical compression tool like Cinva-Ram eliminates the use of power tools, which require oil or electricity. Such power tools are usually too heavy to transfer from one

place to another without a vehicle. A mechanical tool would be easy to carry on a cart anywhere that it is needed.

Perhaps one of the most important aspects of industrialization is the manufacturing process specifically the assembly line; repeating and doing the same thing for better and quicker results. One of the ideas of this design is to apply this modern process into the construction phase. Making earth bricks somewhat involves a production line, but incorporating a mechanical tool into the manufacturing of these bricks adds to the speed as well as the quality of the production.

One of the goals of this thesis is to be able to reach the unskilled laborers in Afghanistan. The idea of manufacturing is applied to the design in the construction phase so it could repeat itself to allow the laborer to become accustomed to the construction. This will help to speed up the construction as well as the quality of it and reduce the cost of building.

The cement that is used in earth bricks is packaged in various sizes of bags, which two people can easily carry. Since it comes in bags it can also be carried in carts. Having a certain amount of cement in the construction might be seen as a conflict due to its cost, but as mentioned previously, the intention of this thesis is also to improve traditional construction methods. Cement and mechanical compression tools do not negate the idea of traditional Afghan architecture, but improve upon it. In fact, the use of cement will sustain the traditional way of construction. This is due to the improved performance of the proposed new design.

6.3 Passive Solar Design

Orientation: It is important to locate the buildings appropriately to gain as much solar heat during the winter, but to avoid too much sun during the summer times. Since it is easy to naturally ventilate during summer, it is more important to consider the heat situation in the winter. Orienting the buildings along an East-West axis⁴ with the larger amount of openings facing to the south would help maximize the solar energy gain in winter and also minimize it in the heat of summer (fig. 26).

Heating: The aim is to attain comfortable indoor climate with higher heating needs (fig. 27). During the wintertime use of a *Taba Khana* is a common type of active heating method in Afghanistan. This method is applied in the prototype during necessary heating times. A series of air channels are designed to convey the heat from *Taba Khana* to the spaces that requires the most heating. A sunspace with large openings collects solar energy and distributes it throughout the main space and during the night works as insulation being an empty, air space. The dome of the prototype is the biggest surface of the building to lose heat. If the site is in a cold climate use of a second layer dome with a mud brick construction as a first layer and an air space between them would minimize the loss of heat. Double-glazing on northern facades also prevents heat lose. Earth walls also help to adjust the temperature of the indoor air throughout the day.

Cooling: The aim is to attain comfortable indoor climate with higher cooling and lower heating needs (fig. 28). Ventilation is the most effective way of cooling. Use of air

movements due to different temperatures around the building helps to reduce internal heat.

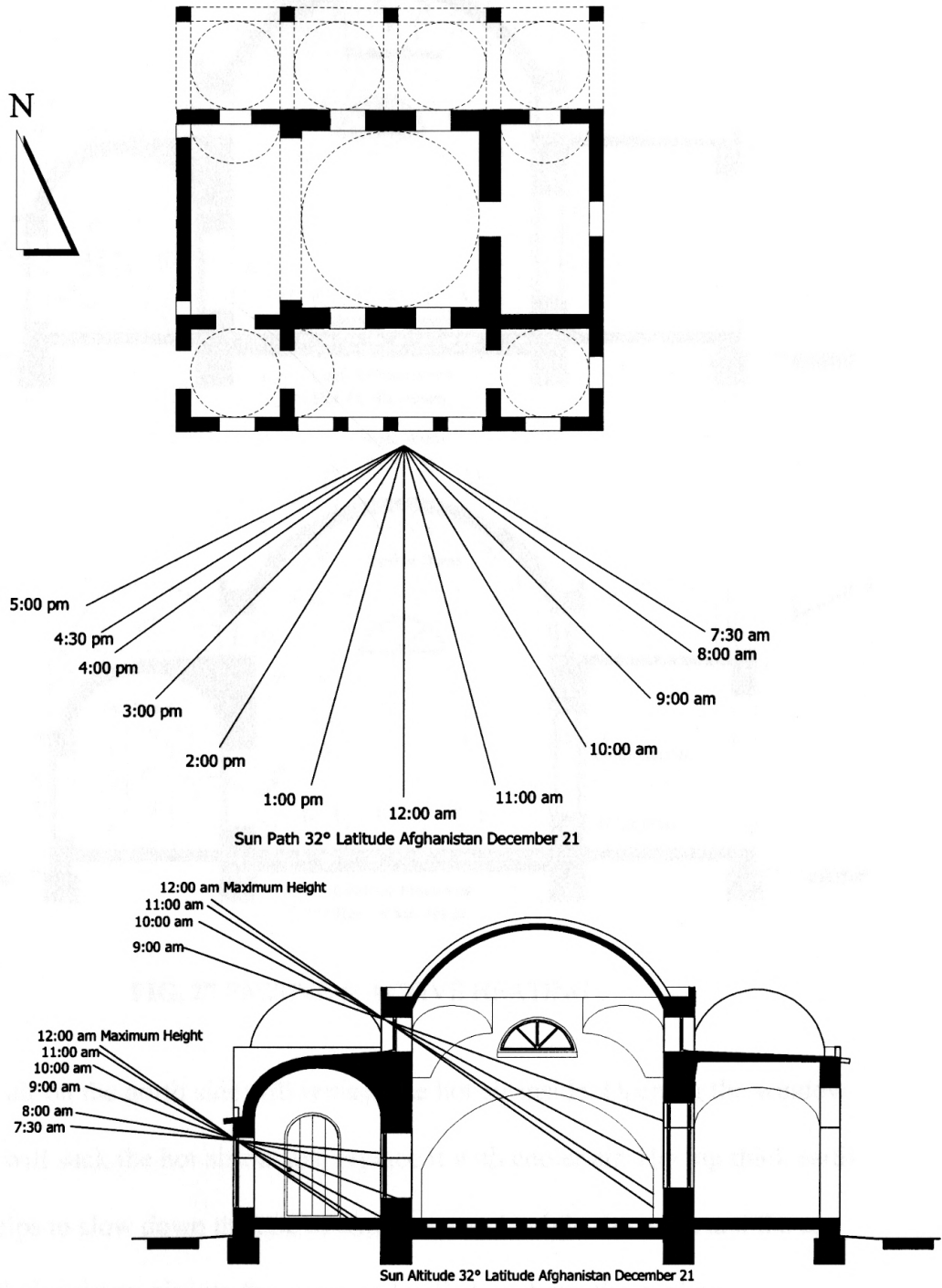

FIG. 26 WINTER SOLAR GAIN

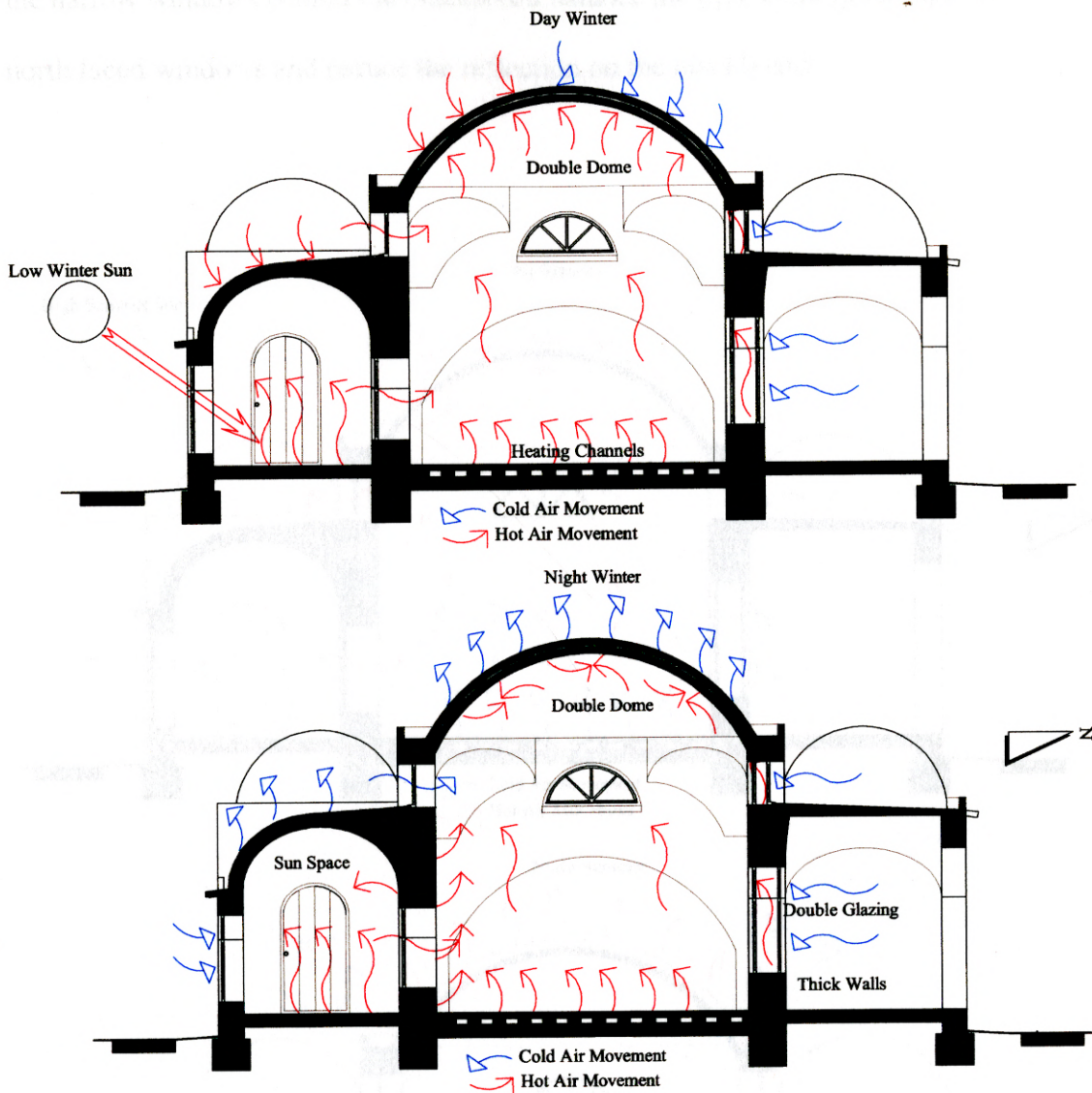

FIG. 27 PASSIVE & ACTIVE HEATING

Shaded cool air on the north side will replace the hot air inside. Opening the window of the dome will suck the hot air out and replace it with cooler air. Having thick earth walls also helps to slow down the rise of temperature. At night the walls and the air channels will give warm air into the space and will slow down the cooling.

Lighting: The spaces in the prototype have enough openings to bring light in. The four half circle windows on the ring beam add more light into the main space. Also

the narrow windows behind the blackboard balance the light coming through the north faced windows and reduce the reflection on the blackboard.

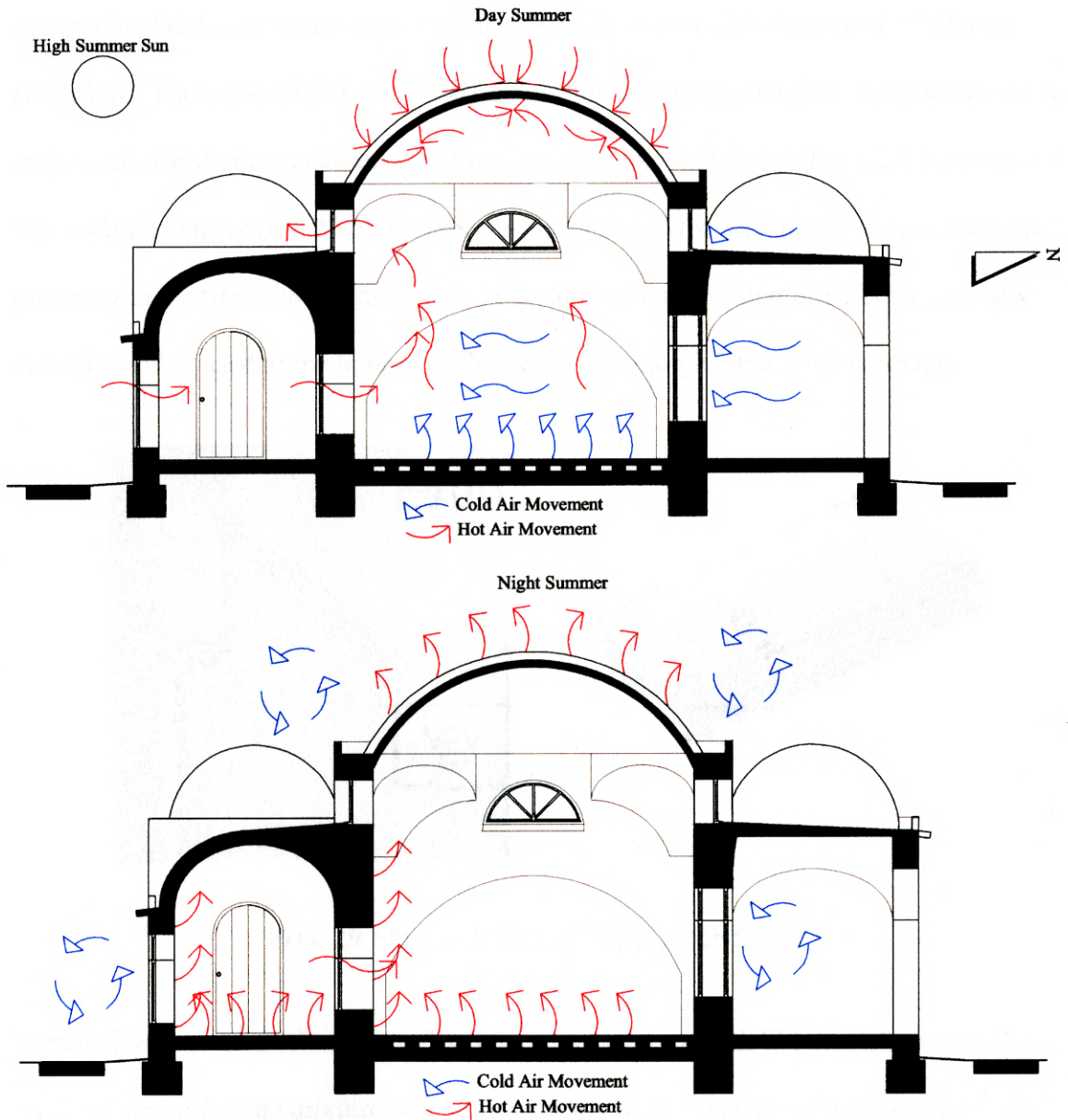

FIG. 28 PASSIVE COOLING

6.4 Elements of the Construction

Brick: There are two types of brick designs to use in the construction of the prototype.

The first brick is for the construction of the walls. It has a size of 10x20x40 cm. Its size will help to reduce production time due to the use of less number of brick in one square meter. One brick can weigh a maximum of 17.6 kg with a high-density of 2200kg/m³

condition.⁵ The second brick is the half size of the first brick, which is designed to use in arch, vault and dome constructions. It has a size of 5x10x20 cm. It has a 2.2 kg weight if it has a high density of 2.2 kg/m³. There is also a brick (fig. 29) that is designed to take the water away from the building. It has the same size of the first brick but a specially curved wood is used at the bottom of the Cinva-Ram to give the brick its shape.

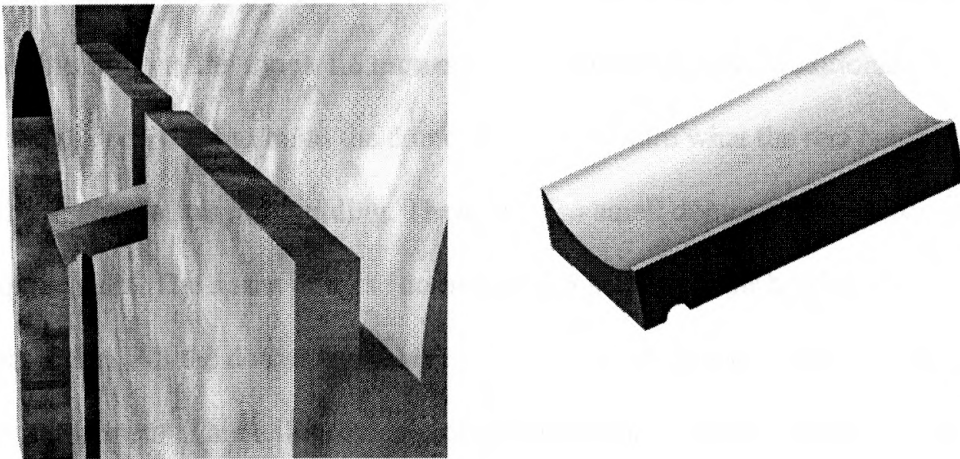

FIG. 29 SPECIAL BRICK FOR RAINSPOUT

Mortar: The mortar used on the walls is the same mixture with 8% cement used in the bricks. Using the same mixture will help the walls work together with the mortar.⁶ The mortar used in the dome has 1/3 or 1/4 cement to soil content to improve adhesiveness

and waterproofing. Also, the roofs are going to be plastered approximately 2 cm in-depth with this mortar to lead the water towards the rainspouts.

Wall: There are two width sizes for the walls in the prototype. One is a 60 cm wide wall surrounding the main cell and the other is 40 cm wide wall, which is used for the rest of the structure. These walls are made out of CSSB. There are also garden walls around the school. These walls are 40 cm wide and made out of traditional earthen architecture. It can be either rammed earth or brick construction. Their height can be adjusted according to the social structure of the area.

Dome: The biggest structural piece of the prototype is a dome of 5 meters span. Its height from the ring beam to the top is 1.6 meters in the design but, since traditional construction is proposed to build the dome, it is not for sure what the real height would be due to the traditional way of building. There are also small domes sitting on top of the small square cells. The spans of these domes are 2.5 meters. Their heights also depend on the construction. All the domes are covered with a 2 cm mortar containing a mixture that is 1/3 of it is cement. This will provide protection from the weather conditions. In colder climates a two-layer dome structure can be built. In this case the first layer from the inside of the space does not have to be constructed with CSSB. It can be mud brick construction.

Vault: The vaults in the prototypes cover the rectangular cells and are built according to the traditional construction methods. The span of the space is 2.5 meters. The assumed

height of the vault is one meter. Depending on the real construction, the ring wall can be raised in order to keep the architectural sequence if the vault height exceeds one meter.

6.5 Spatial Design

An architectural program is carefully chosen to help the design be able to form a basic village school, a rural compound, or a city school. Most of the villages in third world countries have one-unit self-sufficient classrooms or a school structure that can accommodate all the possible grades in the village. It was important that the focus be one unit, which is sufficient in itself and can be expanded into a larger school if needed. This part of the chapter will focus mainly on this single unit starting with the main cell, which is the main space, the classroom. It will continue with alternative program proposals and unit arrangements with all the necessary schematic architectural drawings.

6.5.1 Single Cell, Primary Space

The most important space in a school is the classroom, which is a space where teaching and learning takes place. The design of this space took its shape not just with the idea of the morphological approach or the concept of the architectural design, but also the physical needs of the actual users, the students. The architectural books about designing the classroom spaces and their spatial arrangements are usually shown according to the developed countries requirements. The classroom arrangements in these books are designed according to two students to each desk. However, the reality of a third world country or even in many developing countries, such as Turkey, many schools have classrooms packed with three students to each desk. There are a few good reasons for this

crowded arrangement. First, the population of the young generations is much higher in these countries, and second, the budget for education is so low that there are shortages of classroom units. So it was important to consider the fact that many of the desks might actually be occupied with three students.

A 5mx5m size of a space, besides all the other aspects of the design was actually a good proportional layout for a classroom space in Afghanistan. This main cell has a size that can be the primary space of other programmatic needs. Also, in terms of a geometrical approach, half of this cell can easily be designed into secondary spaces. This approach, designing the primary space first, makes the rest of the design much easier.

Since this is the biggest space with a good size dome, the walls of this space are kept 60 cm wide even though the structural simulations showed no problems when using 40 cm wide walls. Normally a wall with this size of space and this size of dome in a traditional earthen architecture would be no less than 100 cm.

Two sides of the space have windows. The size of the windows can be explained with the construction procedure, importance of light and passive solar design. There are four half-circle windows with an 80cm diameter, which work for natural lighting and ventilation. One side of the space has a door to connect with the other secondary spaces. This door usually opens into a private courtyard or a storage space in the school layout. There is a big arch, which is the only structural element of the design that requires centering to build it, on the last side of the space that connects the classroom unit with the teacher's realm,

where the blackboard and the desk of the teacher is located. This arch has a diameter of 2.5 meters and starts at 0.98 m off the ground. Since the arch starts in front of the desks, the arch does not block any views of the blackboard. The height of the dome is 5.90 m. from the ground to the bottom of the dome. Its height and size indicates the importance of the space. The single cell can be seen in figures 30-40.

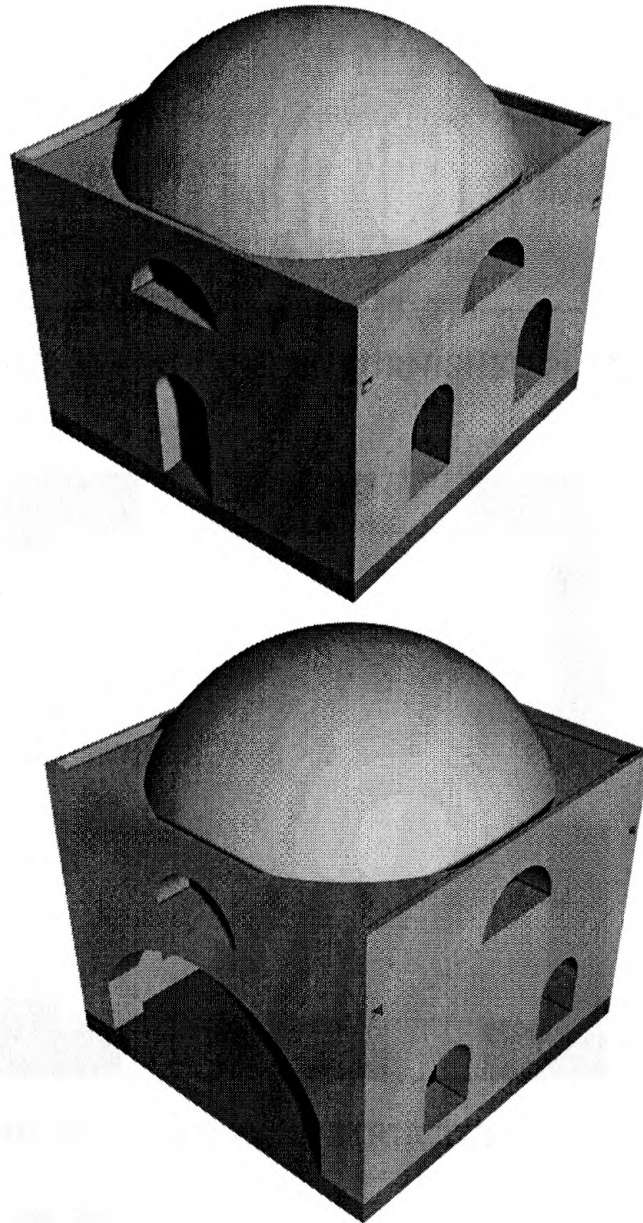

FIG. 30 SINGLE CELL RENDERED PERSPECTIVE

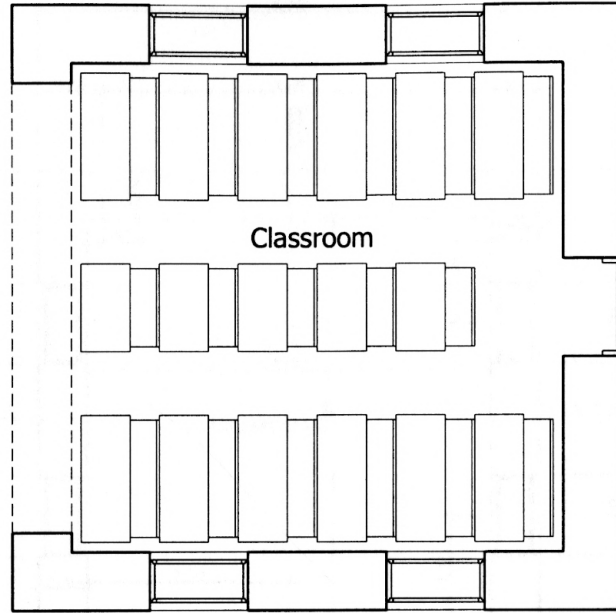

FIG. 31 SINGLE CELL FURNISHED PLAN

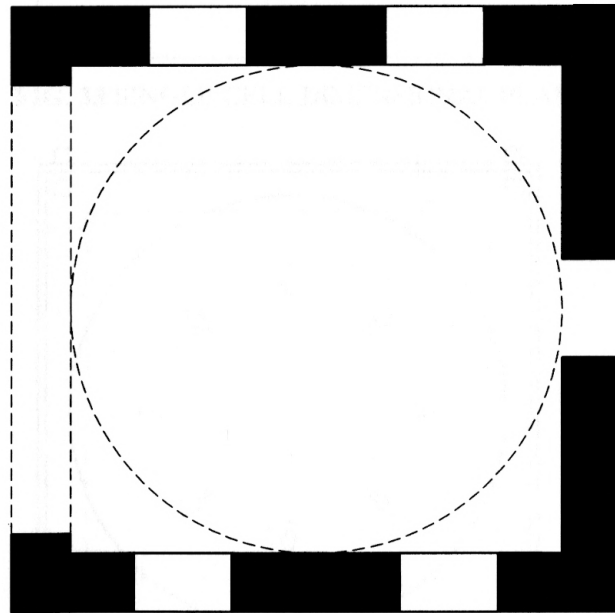
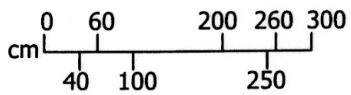

FIG. 32 SINGLE CELL STRUCTURAL PLAN



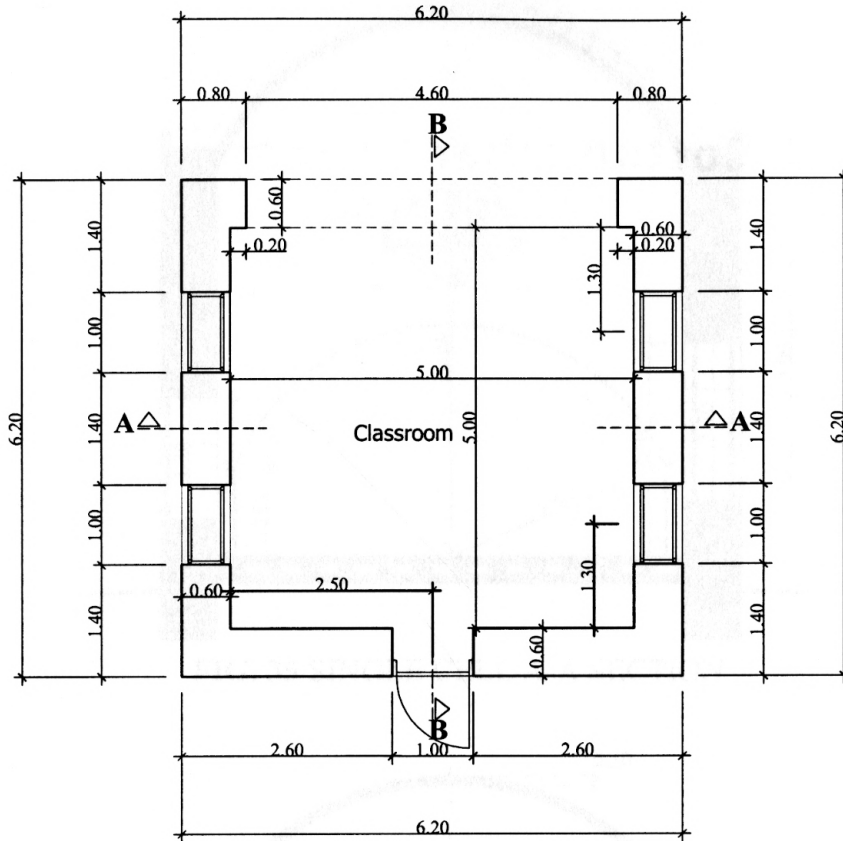

FIG. 33 SINGLE CELL DIMENSIONAL PLAN

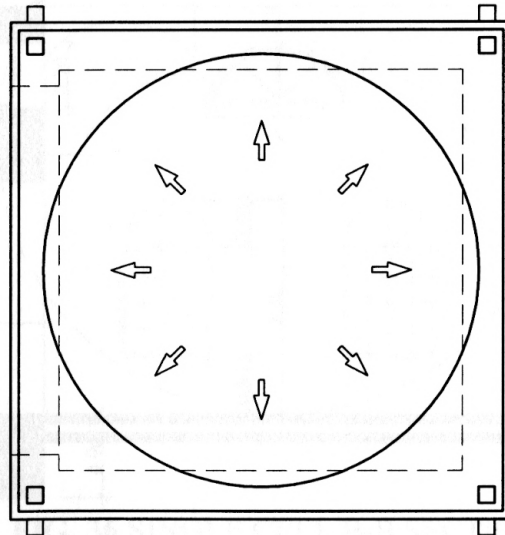
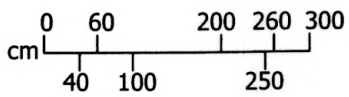

FIG. 34 SINGLE CELL ROOF PLAN



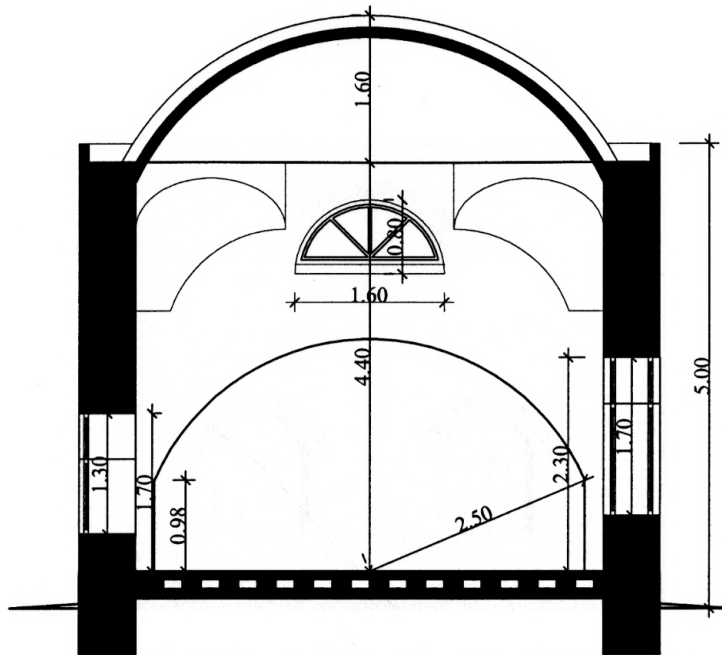

FIG. 35 SINGLE CELL A-A SECTION

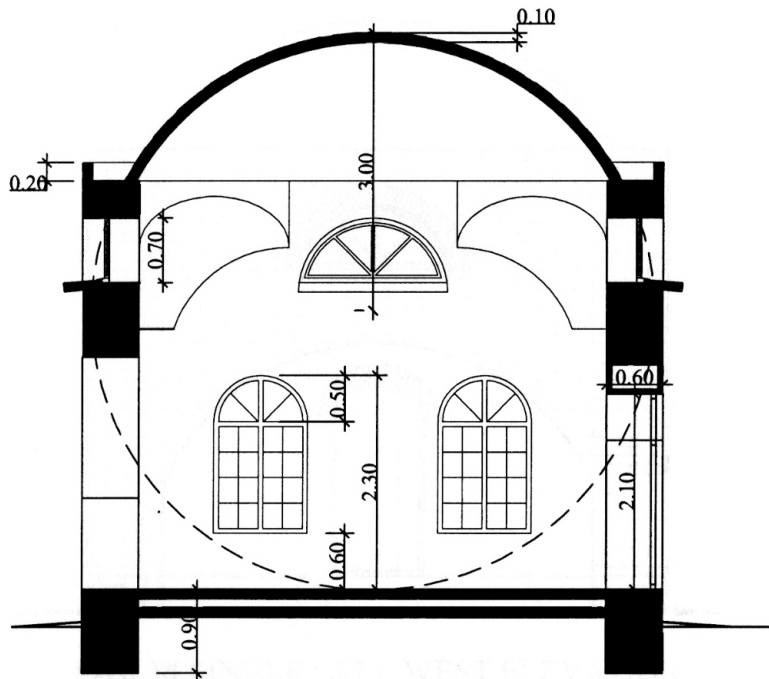
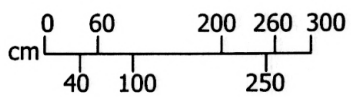

FIG. 36 SINGLE CELL B-B SECTION



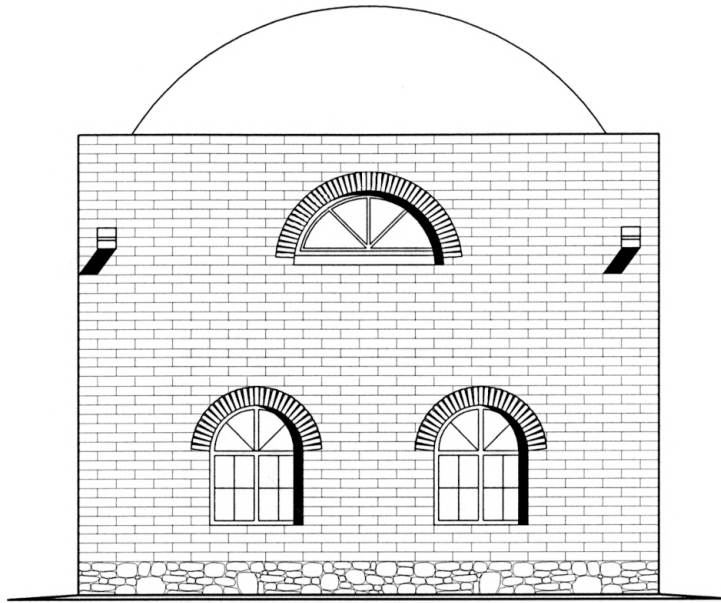

FIG. 37 SINGLE CELL SOUTH ELEVATION

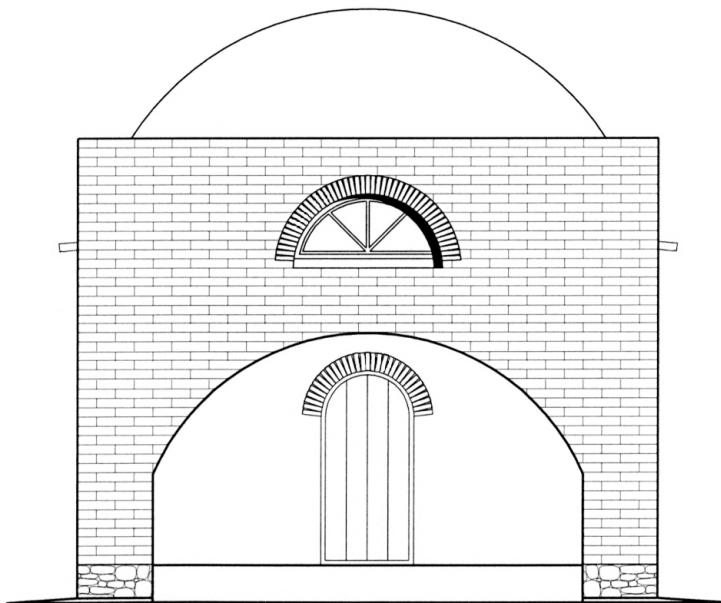
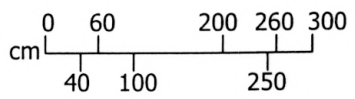

FIG. 38 SINGLE CELL WEST ELEVATION



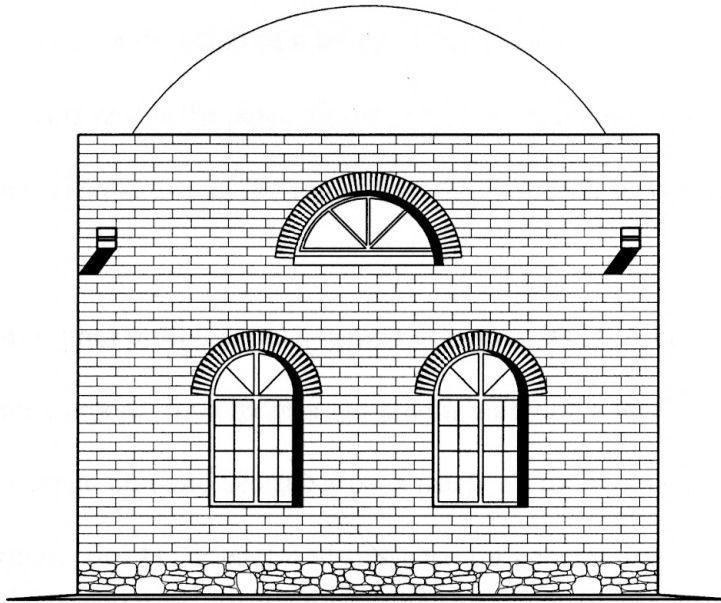

FIG. 39 SINGLE CELL NORTH ELEVATION

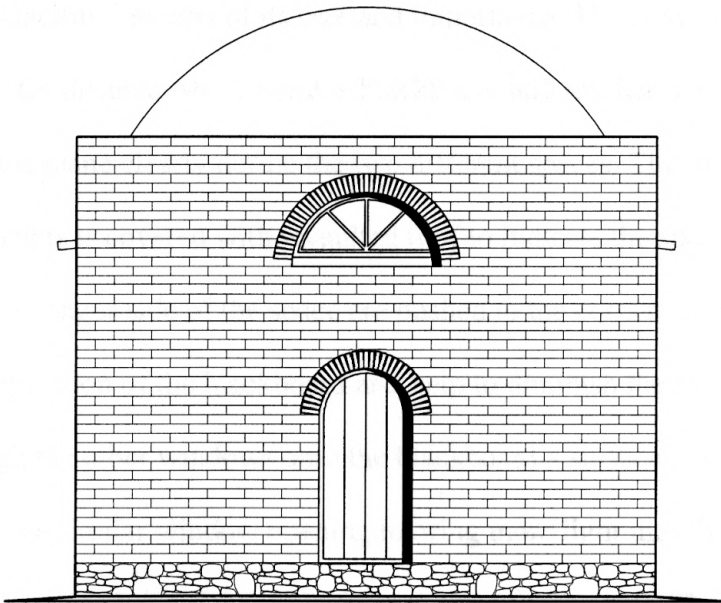
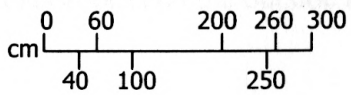

FIG. 40 SINGLE CELL EAST ELEVATION



6.5.2 Single Unit and Alternative Unit Proposals

The single unit is a combination of a series of cells that are related to the main cell in plan geometry. This unit is the main layout of all the other units and plan alternatives. It is a combination of squares and rectangular spaces that each serves different purposes.

This single unit school prototype is designed to sustain itself. A basic school program is shrunk to fit this purpose. It includes a classroom unit with a teacher's desk and blackboard, a storage unit and heating area, a teacher's room, an entrance and an open courtyard (garden) (fig. 41) or enclosed sunspace for general use.

The classroom area, which was explained previously is the center of the unit and dominates the facility in terms of its size and importance. The arch in the classroom space visually separates the area where there is blackboard and teacher's desk. This arch and its projection to the plane clearly define the two different spaces. This rectangular space, 2.5 meters by 5 meters is covered with a vaulted roof to indicate the space underneath. The windows on the longer side of the space are pushed to the corners and designed to indicate the separation of the blackboard and help to diminish the intensity of the light coming through the other windows onto the blackboard's surface. One of the short sides of the space has a similar window opening to bring more light into the space. The other short side of the space has a door connecting to the entrance hall. The entrance hall is one fourth of the main cell covered with a small dome. It works as a weather barrier between the classroom and the outside and also works as a foyer. It has two other doors.

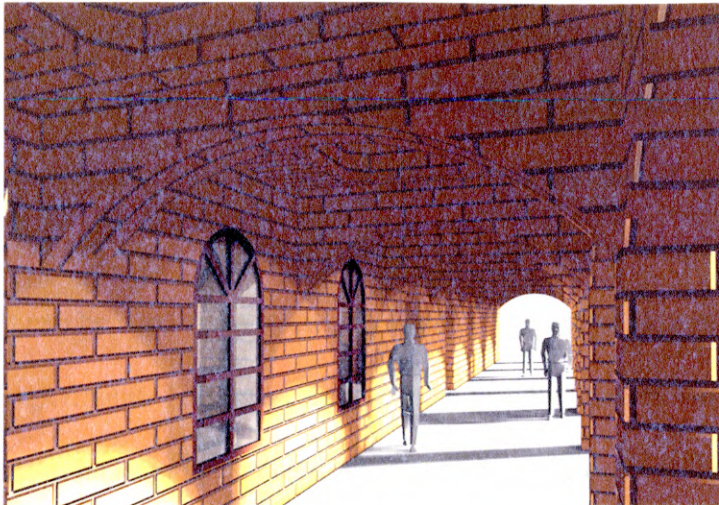

Colonnade Space: This works as a transitional space between the units. It also contributes to the passive solar design.



Garden Space: This is a place where students or other users can grow plants and vegetables.



Courtyard Space: It is a common gathering space between two-classroom units. It can serve as a playground or outdoor classroom.

FIG. 41 ALTERNATIVE OUTSIDE SPACES

One opens to the outside and the other door opens to the sunspace or the courtyard. The side that looks to the south has a window, which collects heat and light. The sunspace, *iwān* or courtyard has a rectangular shape and is half the size of the main cell. It has a series of windows to collect and distribute heat during cold weather. If the climate is hot it can be used as an open courtyard. It is a space to play, interact, connect, and experiment. This space opens to the teacher's room, which is a small square cell. The room has enough space to accommodate one or two teachers and is well lighted. The storage and heating room is also a rectangular space that is located behind the main classroom space. Anything can be stored in the space. It also keeps any source of fuel to be used in the heating area (*Taba Khana*). The last part of the unit is the covered arcade, which provides additional playground. It can also be used for passive energy design having the benefit of cool, shaded space and it works as a transition when there is more than one unit. The drawings can be seen in figures 42-61 in more detail.

This unit can be altered for other type of programs that can be in a larger school. The unit can be used as a house or a mosque. *The mosque* (fig.62) is divided into two main praying halls for men and women. They each have their own entrance and between are series of curtain-covered windowed doors. The doors can be opened if the mosque is in use for men or women. The sunspace section of the unit can be used for the late arrivals for praying or can be used as a study area or consultation. The dominant dome in this case represents the main prayer hall.

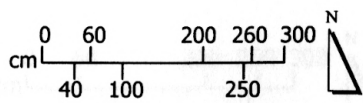
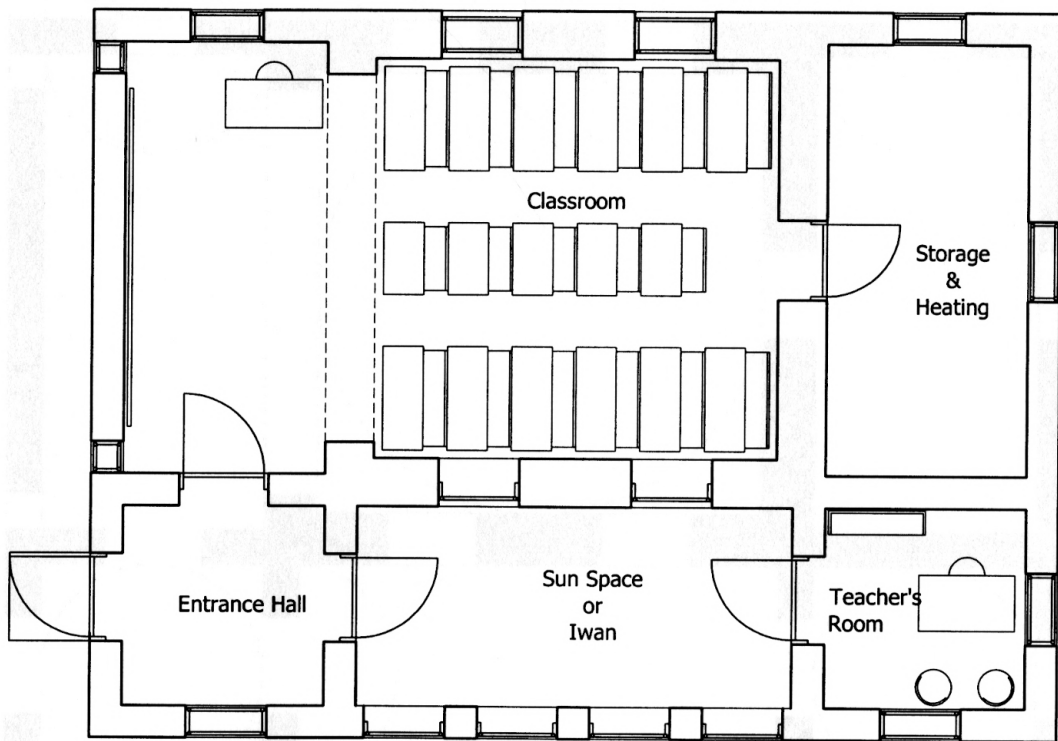

FIG. 42 SINGLE UNIT FURNISHED PLAN

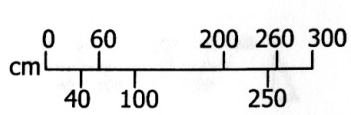
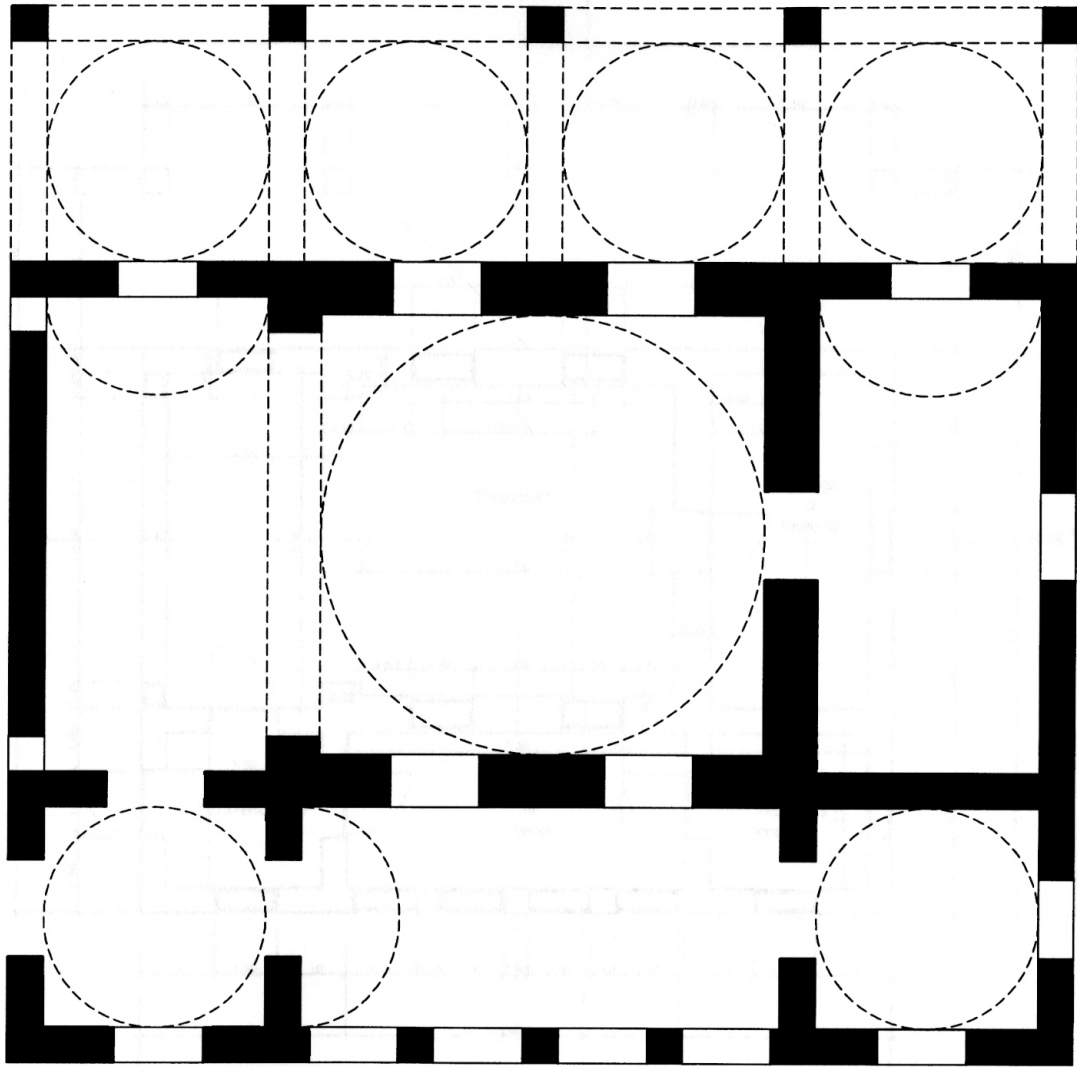

FIG. 32 SINGLE UNIT STRUCTURAL PLAN

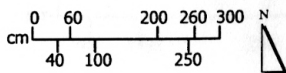
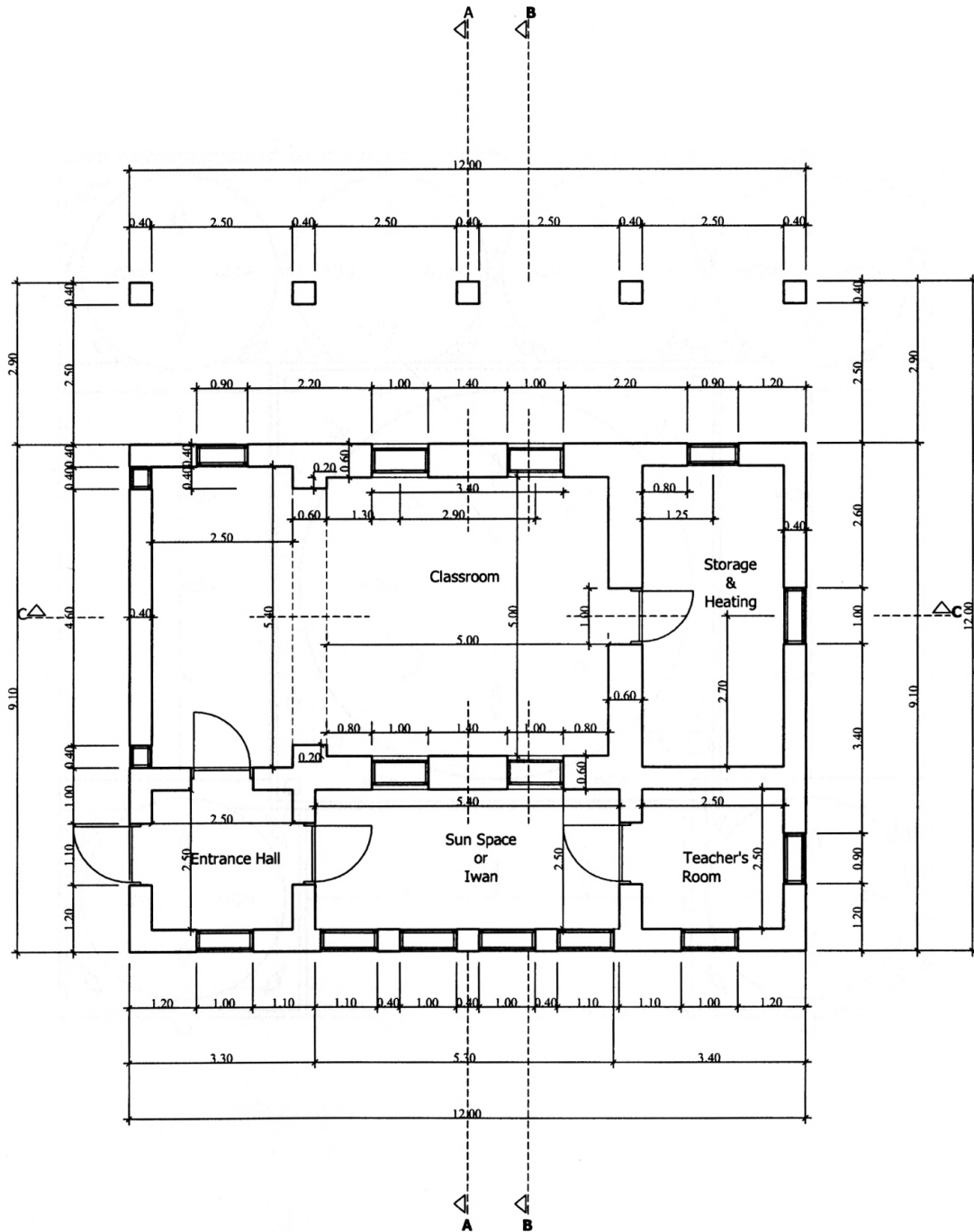

FIG. 44 SINGLE UNIT DIMENSIONAL PLAN

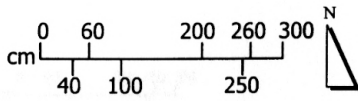
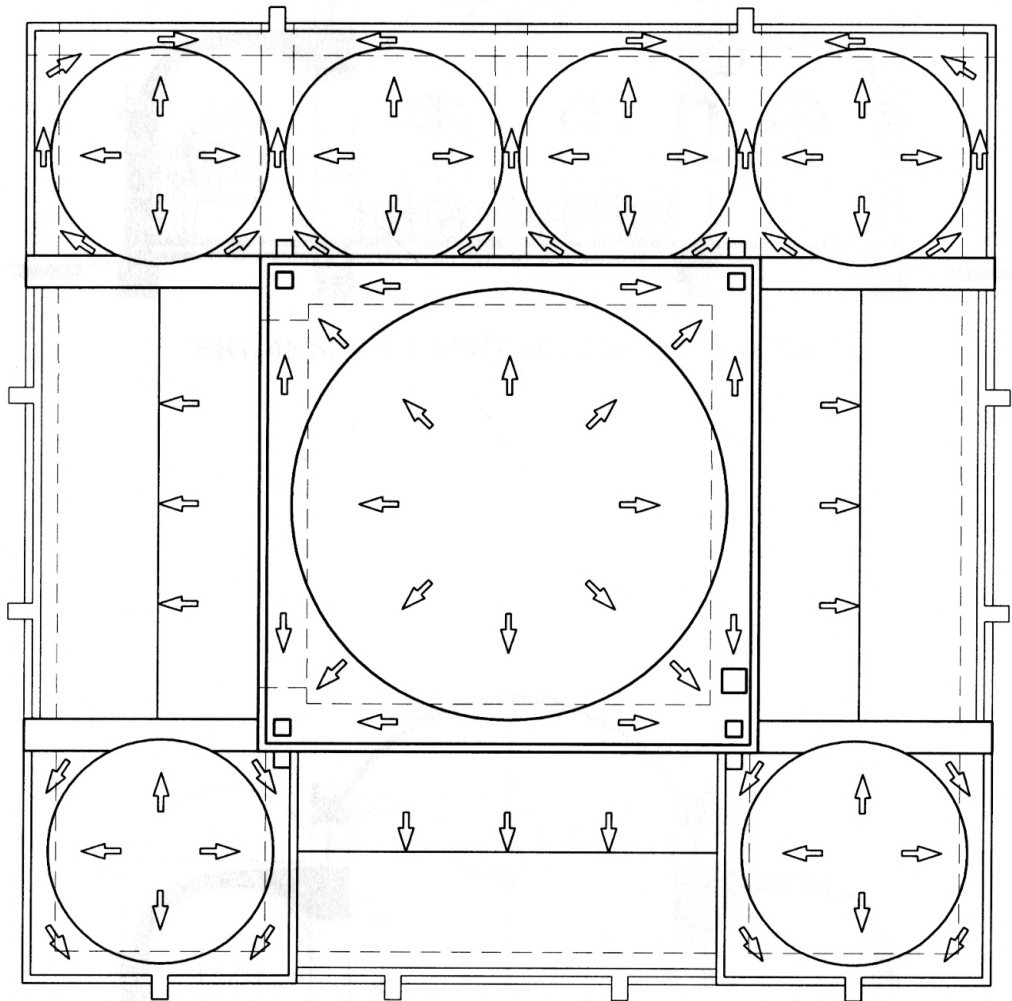

FIG. 45 SINGLE UNIT ROOF PLAN

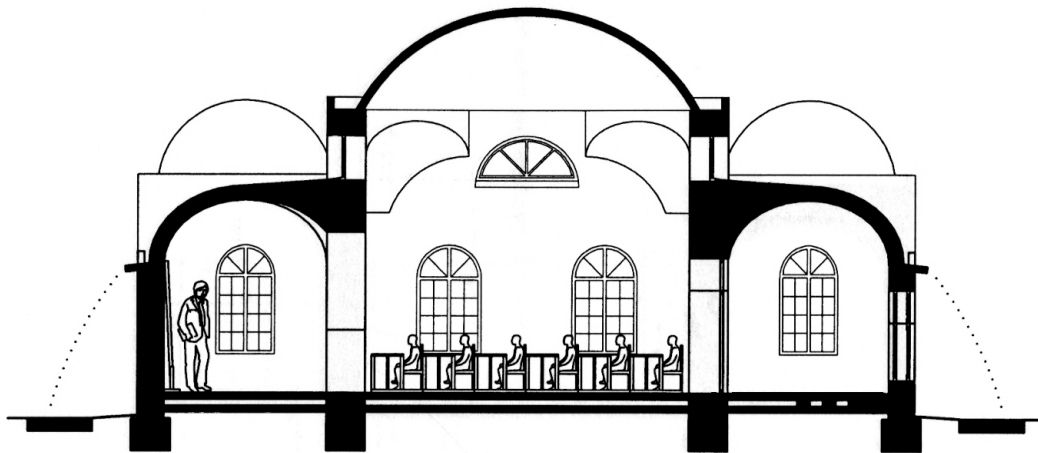

FIG. 46 SINGLE UNIT SCHEMATIC SECTION

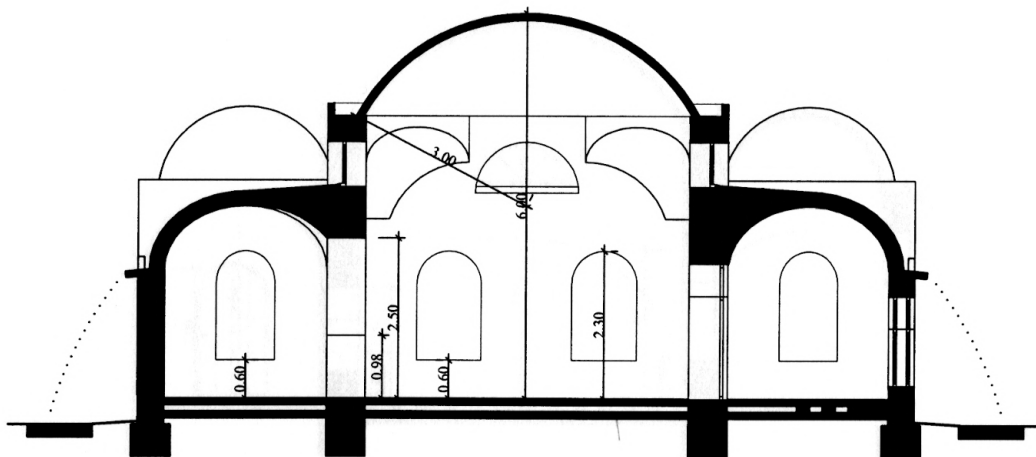
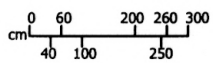

FIG. 47 SINGLE UNIT C-C SECTION



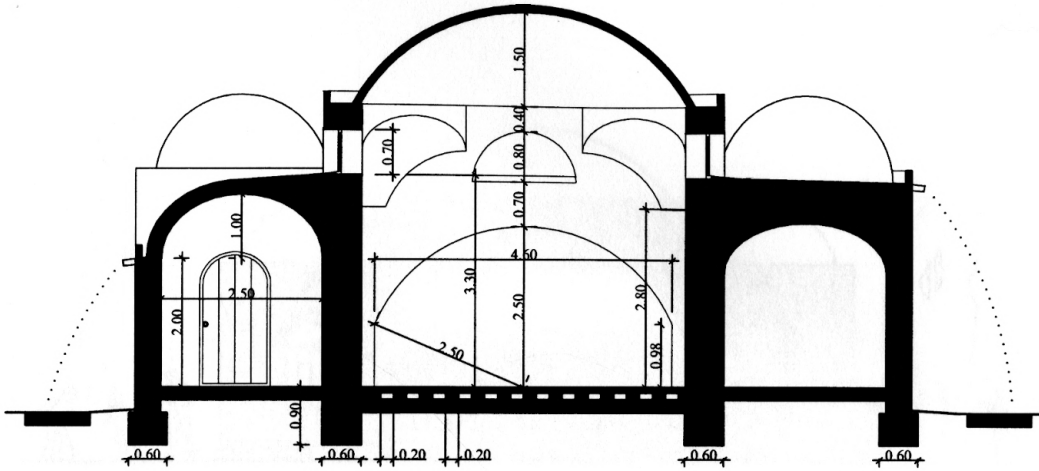

FIG. 48 SINGLE UNIT A-A SECTION

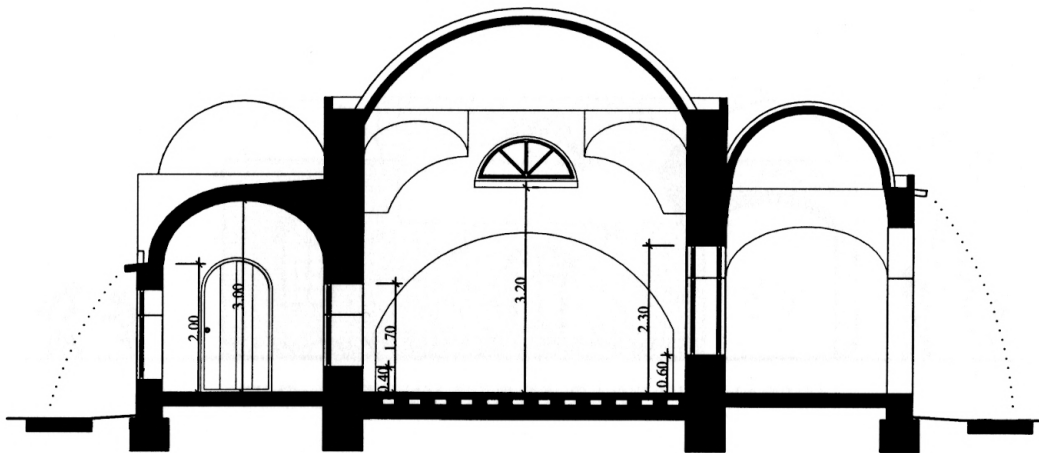
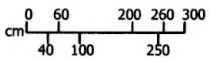

FIG. 49 SINGLE UNIT B-B SECTION



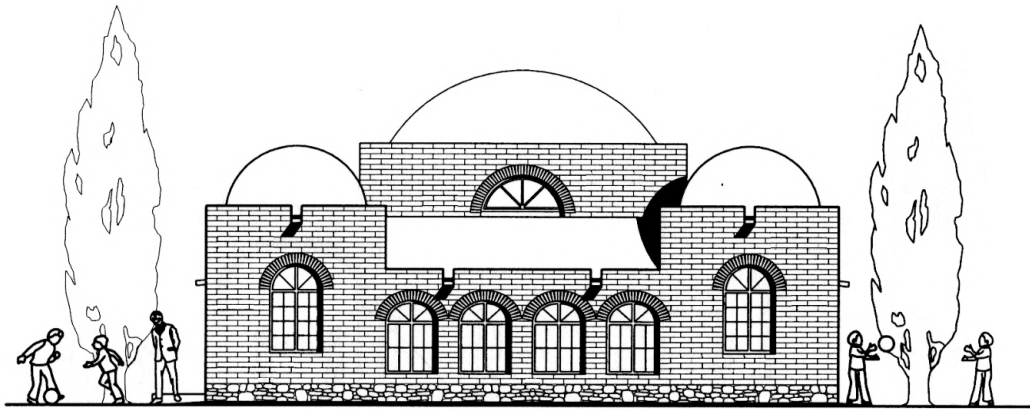

FIG. 50 SINGLE UNIT SOUTH ELAVATION

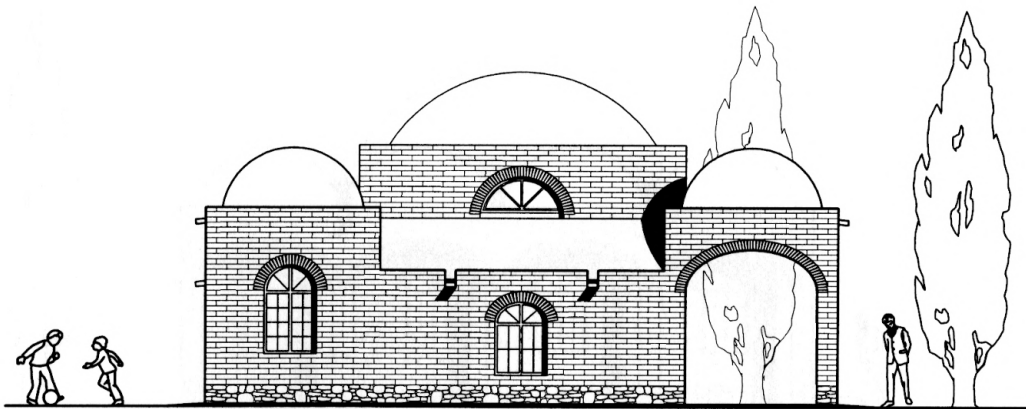
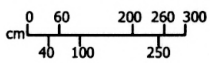

FIG. 51 SINGLE UNIT EAST ELEVATION



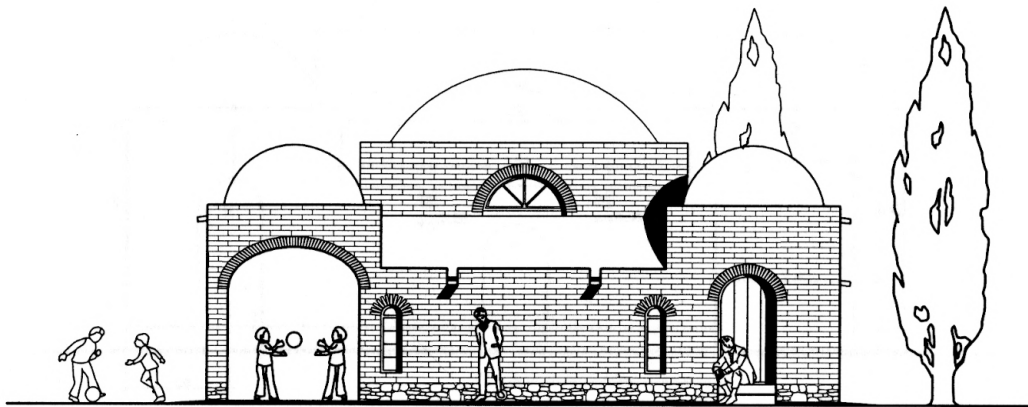

FIG. 52 SINGLE UNIT WEST ELEVATION

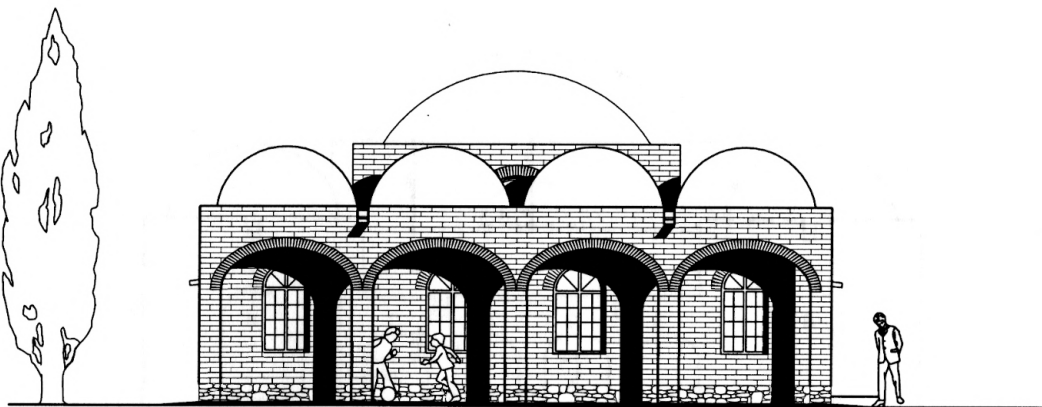
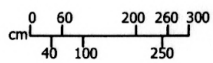

FIG. 53 SINGLE UNIT NORTH ELEVATION



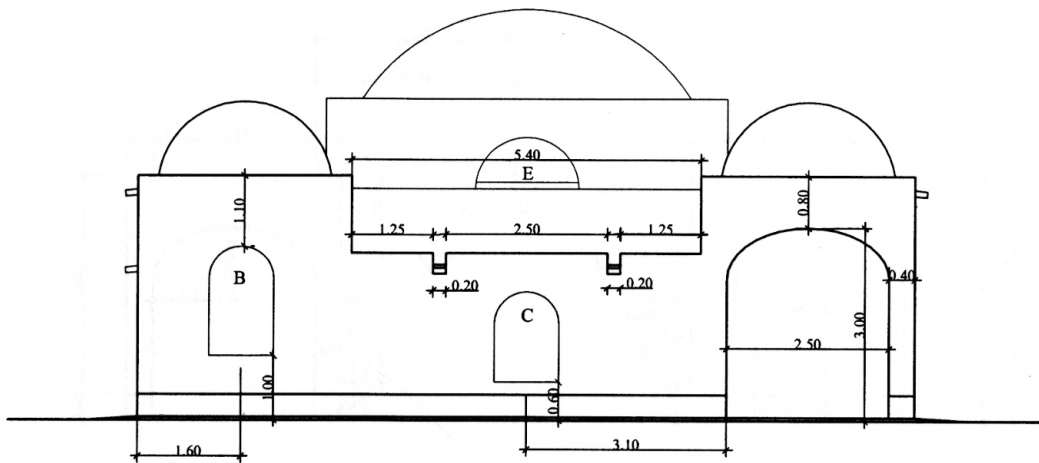

FIG. 55 SINGLE UNIT DIMENSIONAL EAST ELEVATION

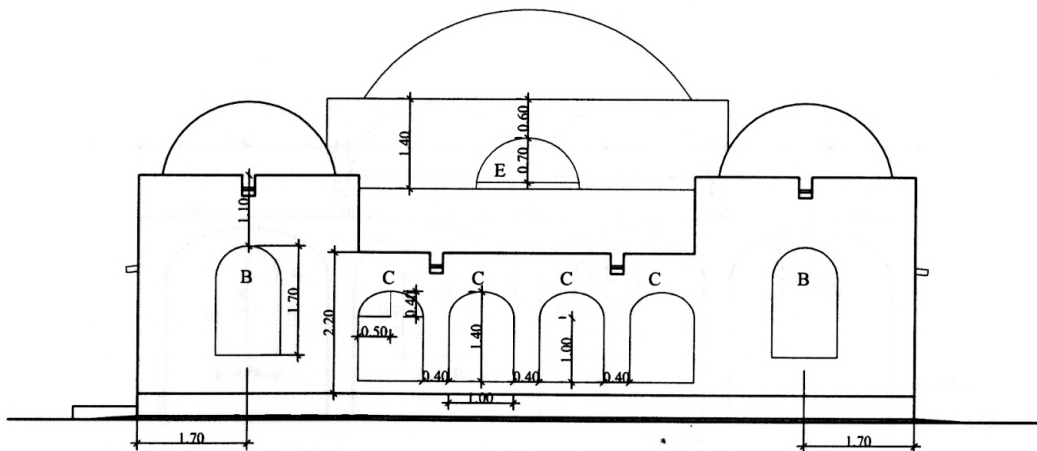
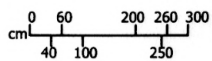

FIG. 54 SINGLE UNIT DIMENSIONAL SOUTH ELEVATION



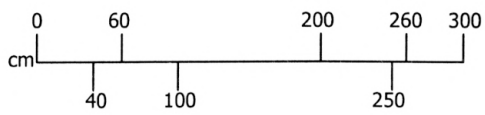
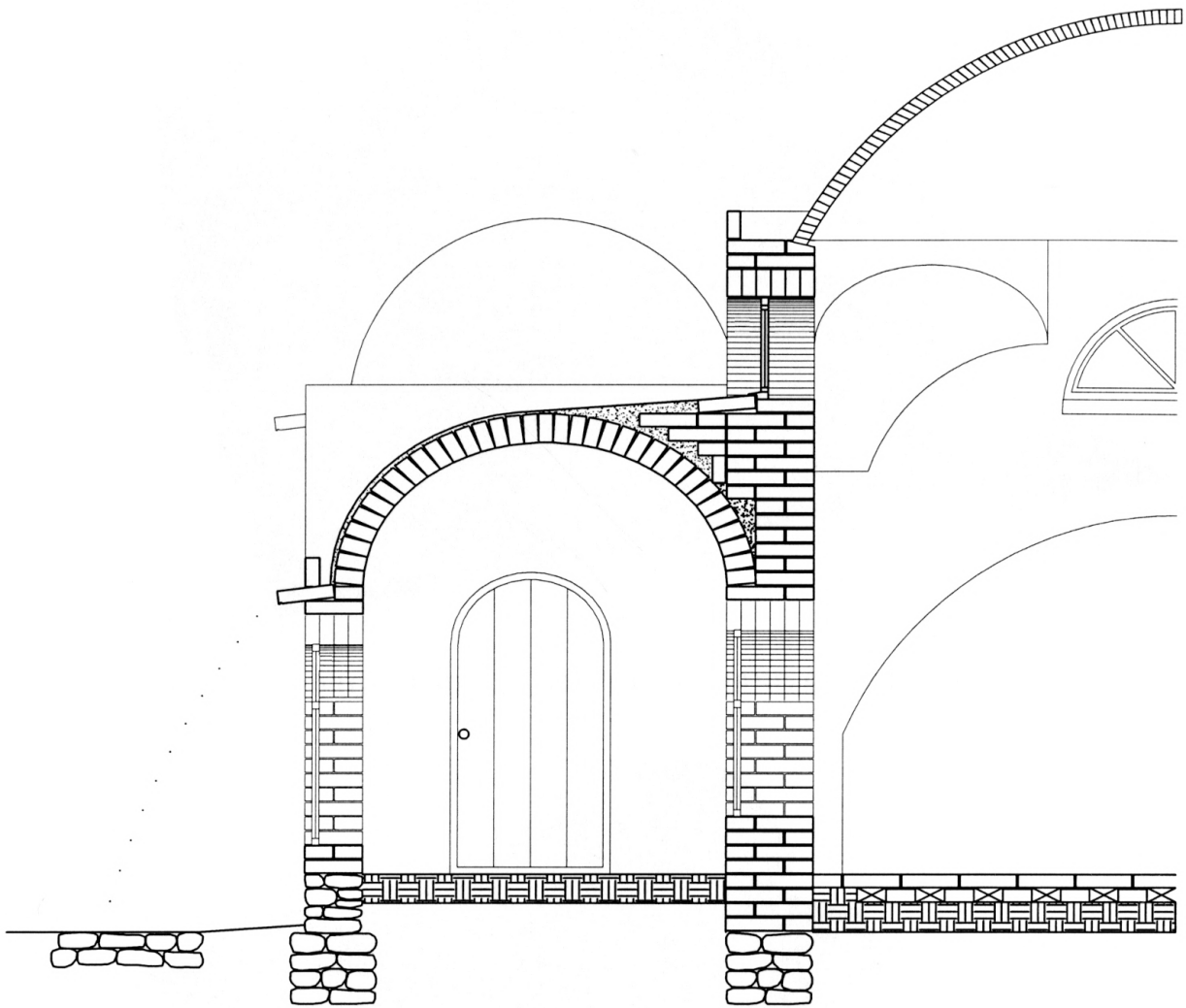

FIG. 58 SYSTEM DETAIL

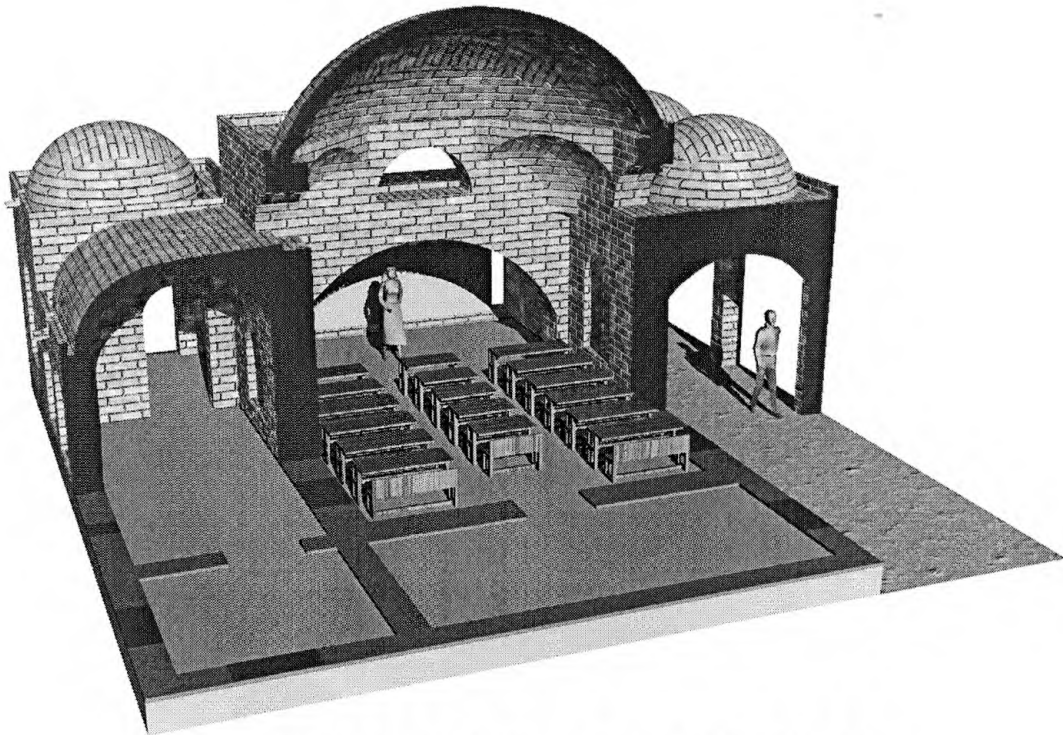

FIG. 59 SINGLE UNIT RENDERED SECTION A-A

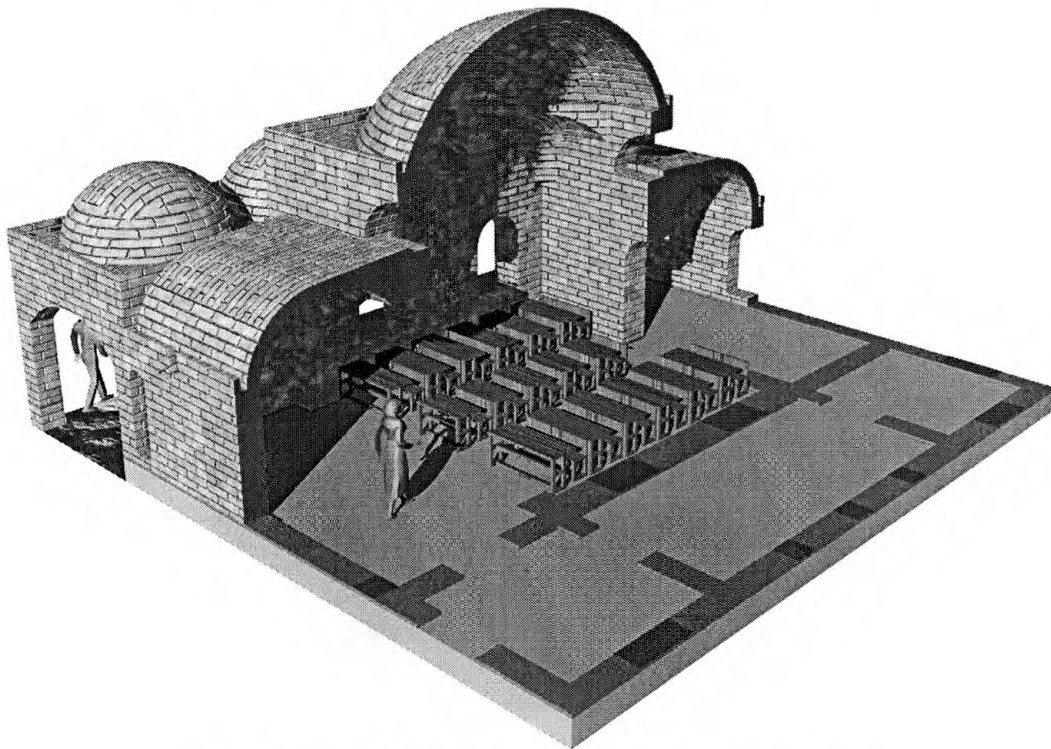

FIG. 60 SINGLE UNIT RENDERED SECTION C-C

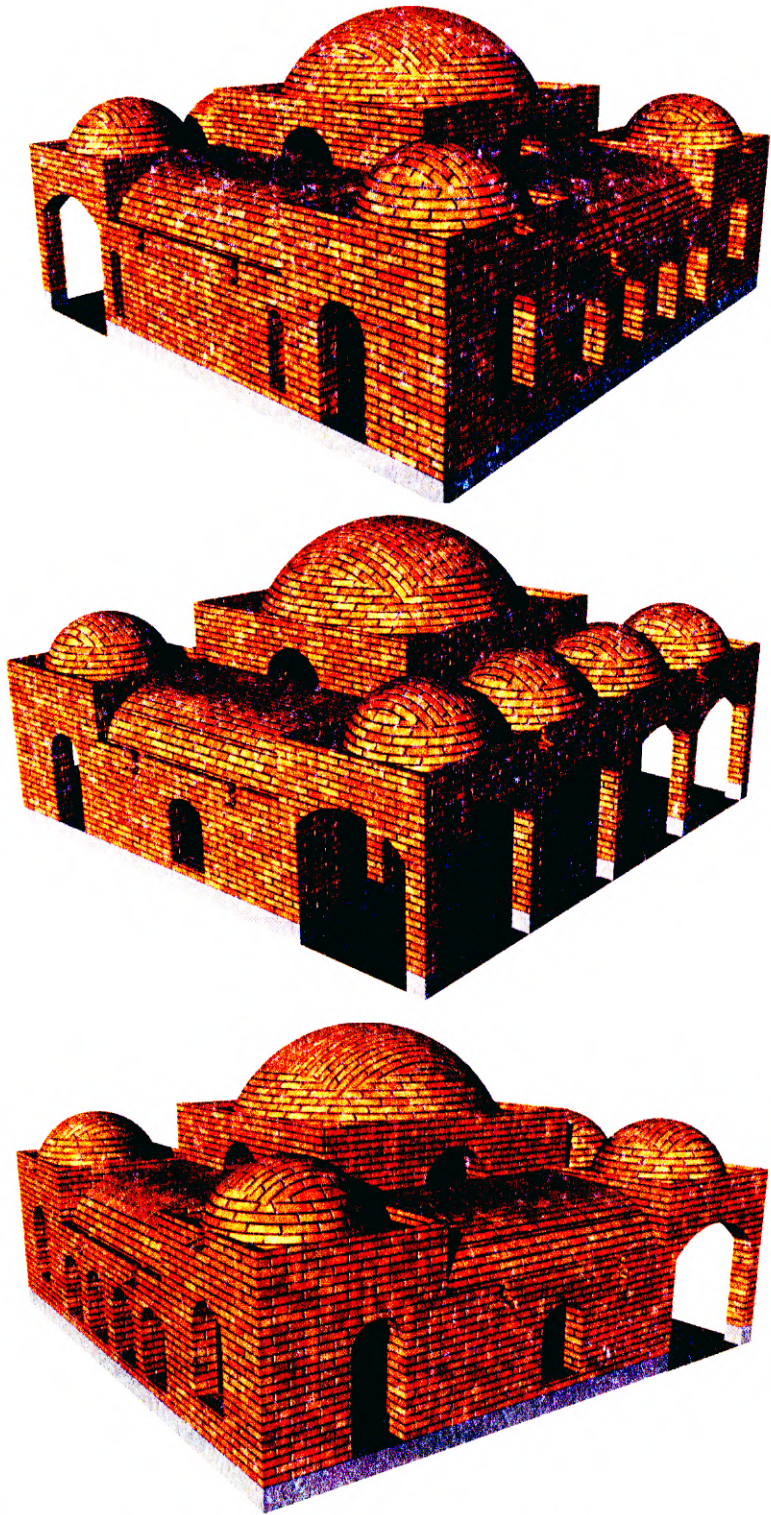

FIG. 61 SINGLE UNIT RENDERED PERSPECTIVE

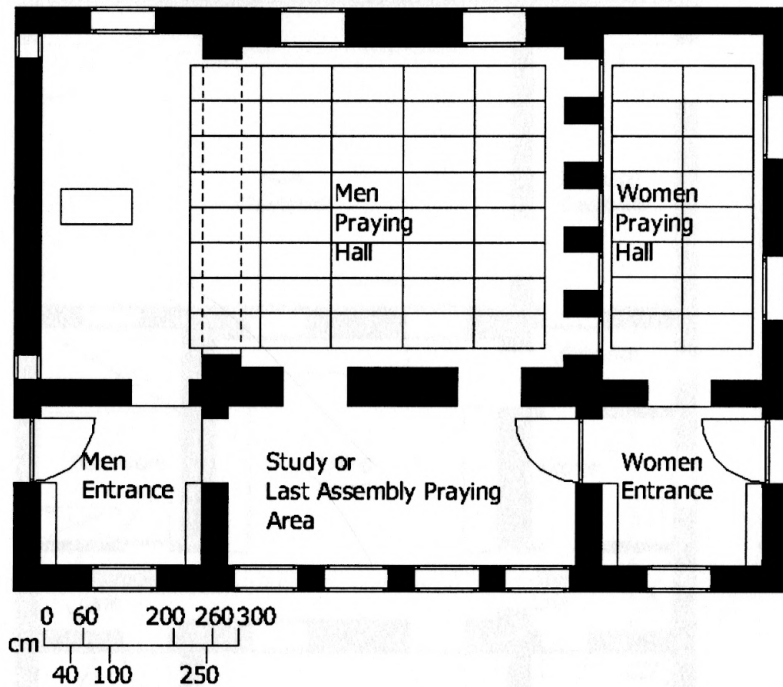

FIG. 62 MOSQUE PLAN

The space where the arch connects to the main hall to the rectangular vaulted space is for the Imam to lead the prayer. *The house* (fig.63) has two separate bedrooms, a bathroom, a kitchen, an entrance, a living room, a private courtyard, a main courtyard, and an entrance courtyard. The living room is underneath the main dome, which represents the primary space. The living room can also be used as a sleeping area like in many Afghan houses. The main courtyard and the entrance courtyard are surrounded with a wall that extends the arcade part of the unit. The entrance courtyard is a semi-public area that connects the school and the house. The main courtyard is a space for animals, planting, storing and collecting items, etc. It is half covered for weather protection and half open.

There is also one private courtyard that provides more sitting and relaxing purposes. The space can also be enclosed in case the family needs more room in the future.

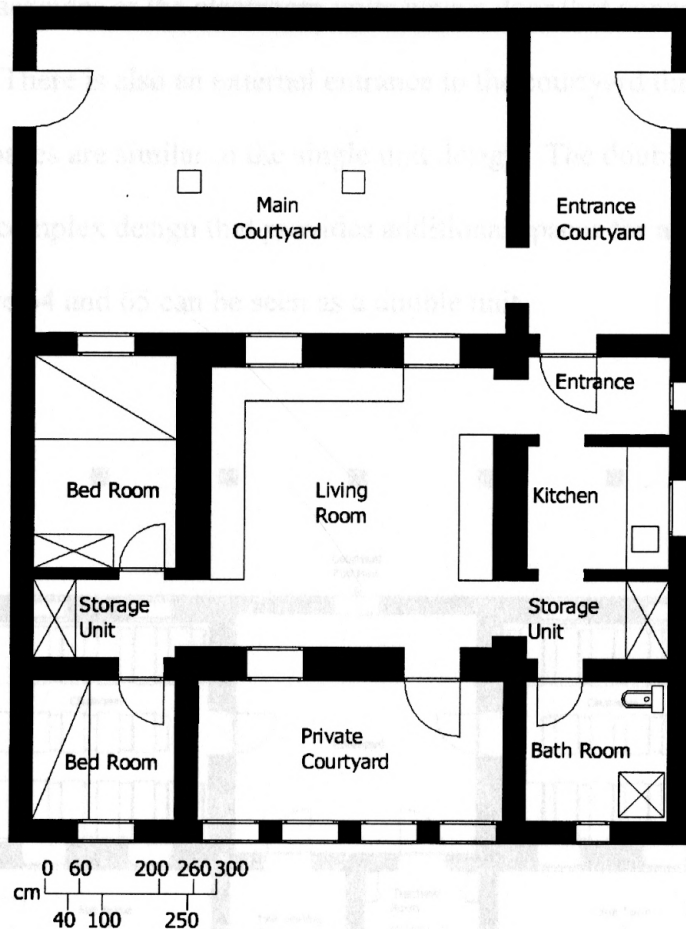

FIG. 63 HOUSE PLAN

The kitchen and bathroom are connected with a storage facility that serves for these two spaces. There is another storage area between the two bedrooms. The bathroom is also used for heating purposes.

6.5.3 Double Units and Alternative Unit Proposals

This is a two-classroom unit school with a central courtyard that connects two single units (fig. 64 & 65). In this case the storage and heating unit of the single unit becomes

half of the courtyard. The courtyard serves as an open storage area as well as a playground for the two-unit. A heating room and teachers' room opens through the courtyard. The backsides of the classroom units have a door that connects the classrooms to the courtyard. There is also an external entrance to the courtyard through the arcade. The rest of the spaces are similar to the single unit design. The double unit scheme can be altered into a complex design that provides additional spaces for a school. The drawings in figure 64 and 65 can be seen as a double unit

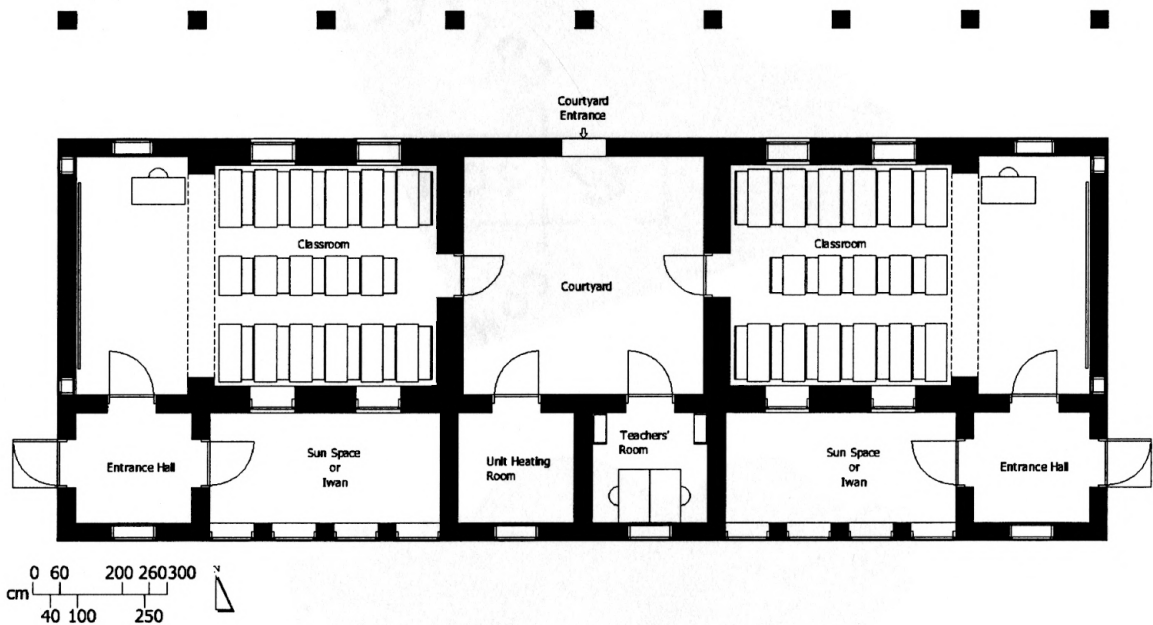

FIG. 64 DOUBLE UNIT SCHOOL PLAN

designed for administrative purposes as well as a common school facility area such as a library and /or assembly hall (fig. 66).

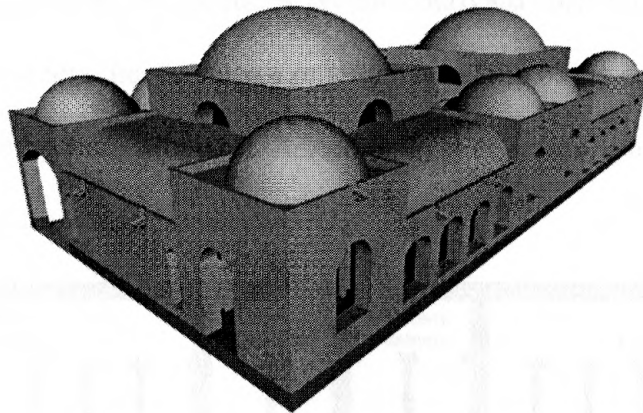
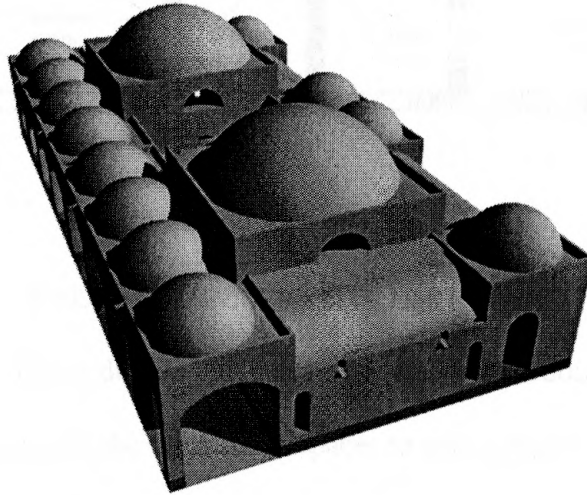
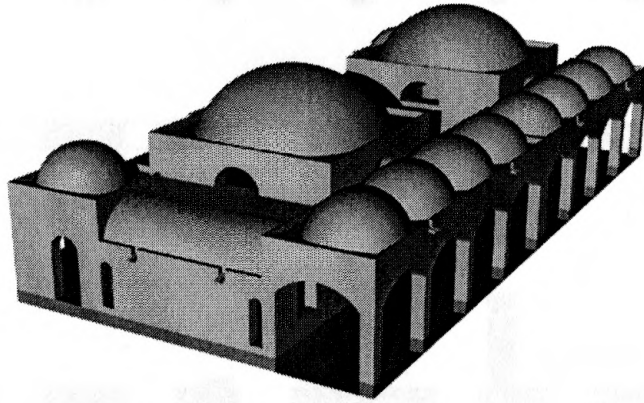

FIG. 65 DOUBLE CLASSROOM SCHOOL UNIT SHADED PERSPECTIVE

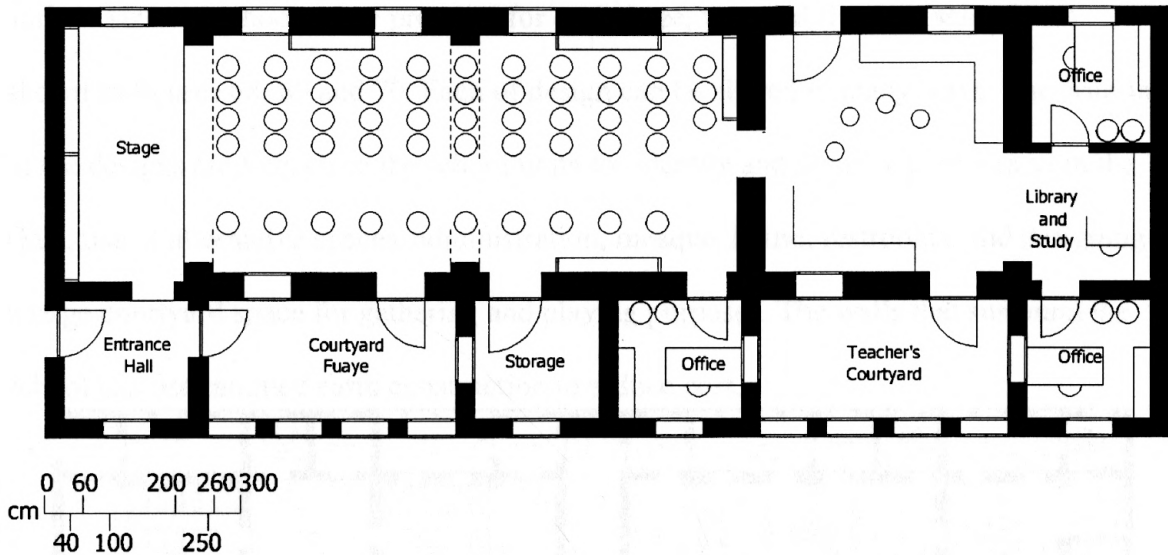

FIG. 66 ADMINISTRATIVE UNIT PLAN

The common courtyard of the double unit can be covered with a dome similar to the main dome and connected to one of the other main spaces to gain a bigger rectangular space. The faculty area of this unit has two offices for administration and a lounge for teachers with a library or study area on the corner. A private courtyard takes the place of the sunspace for use of teachers' needs. Also a restroom area (fig. 67) is designed using the arcade space enclosed by walls around it. A second layer of arcade can be designed in front of the restrooms for weather protection.

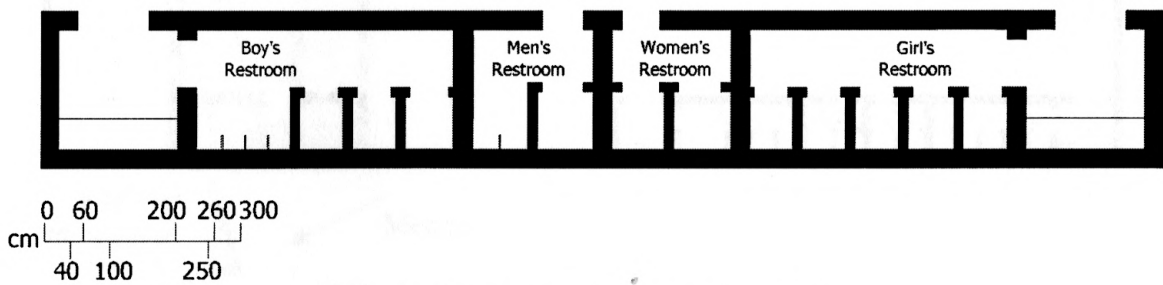

FIG. 67 RESTROOM UNITS PLAN

6.4.4 Master Plan of the School

A single unit prototype is designed with other alternative unit proposals to assemble various sizes of schools. One proposal for each three, four and five unit schools are shown in figures 68, 69 and 70. Each of design can be altered in many ways. The criteria of the designs are to enclose the school units for identity and security purposes as in the Qala, use of alternative spaces, administration, mosque, house, restrooms, and designing a large courtyard space for gathering and playing purposes. The walls that surround the school can use rammed earth construction to reduce cost.

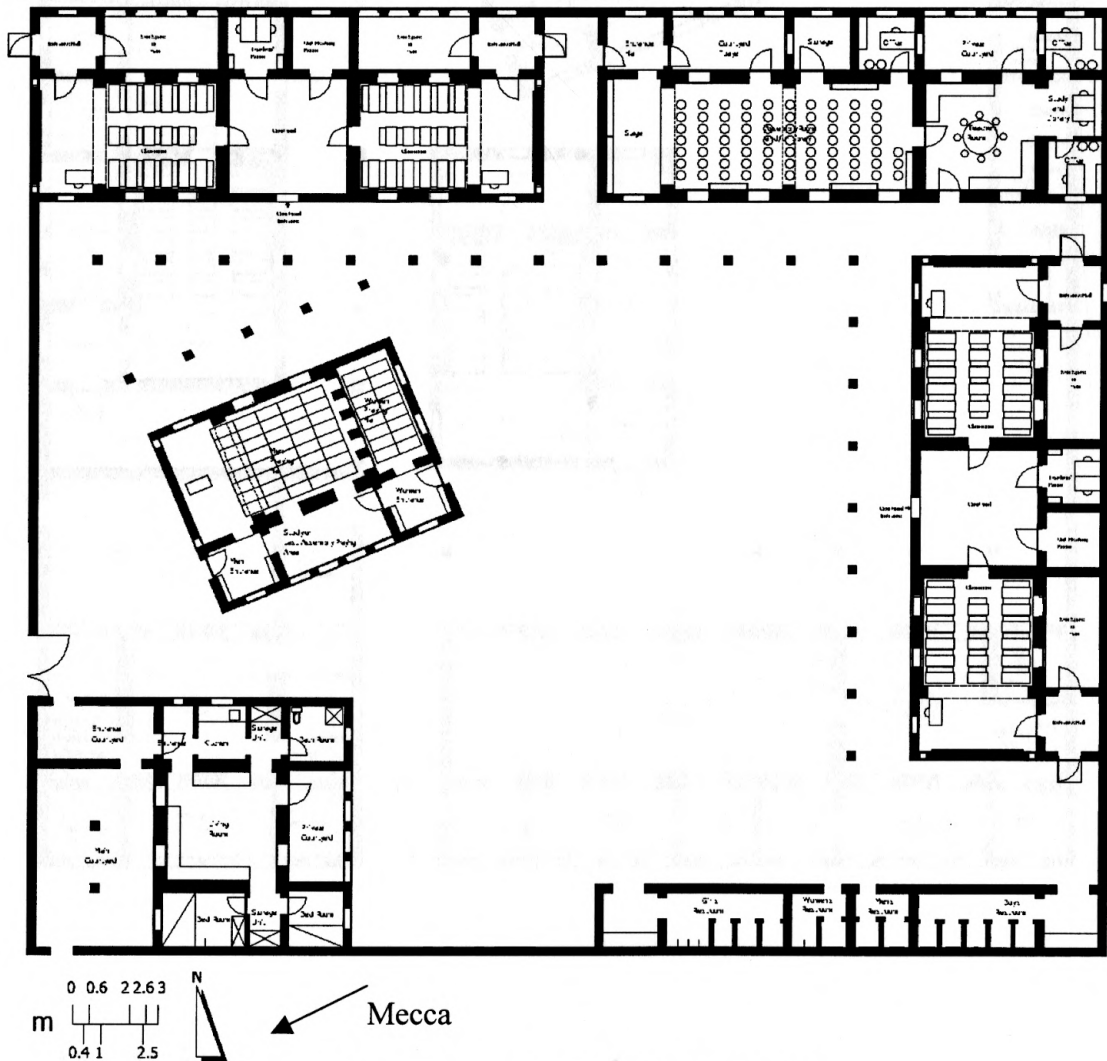

FIG. 68 FOUR UNIT SCHOOL PLAN

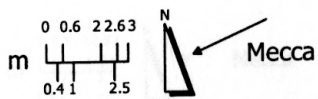
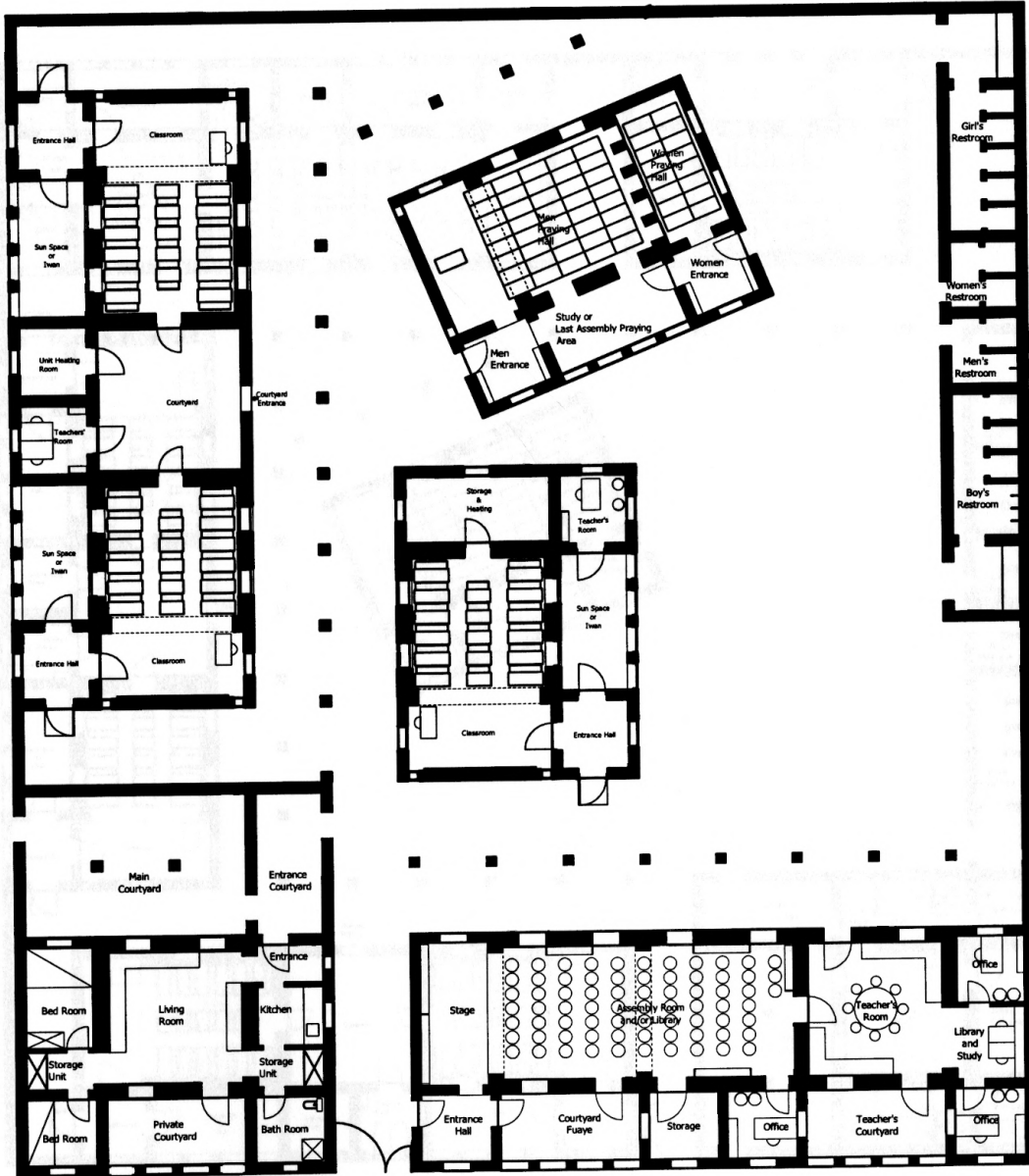

FIG. 69 Three Unit Arrangement

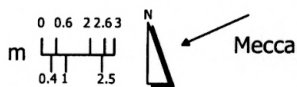
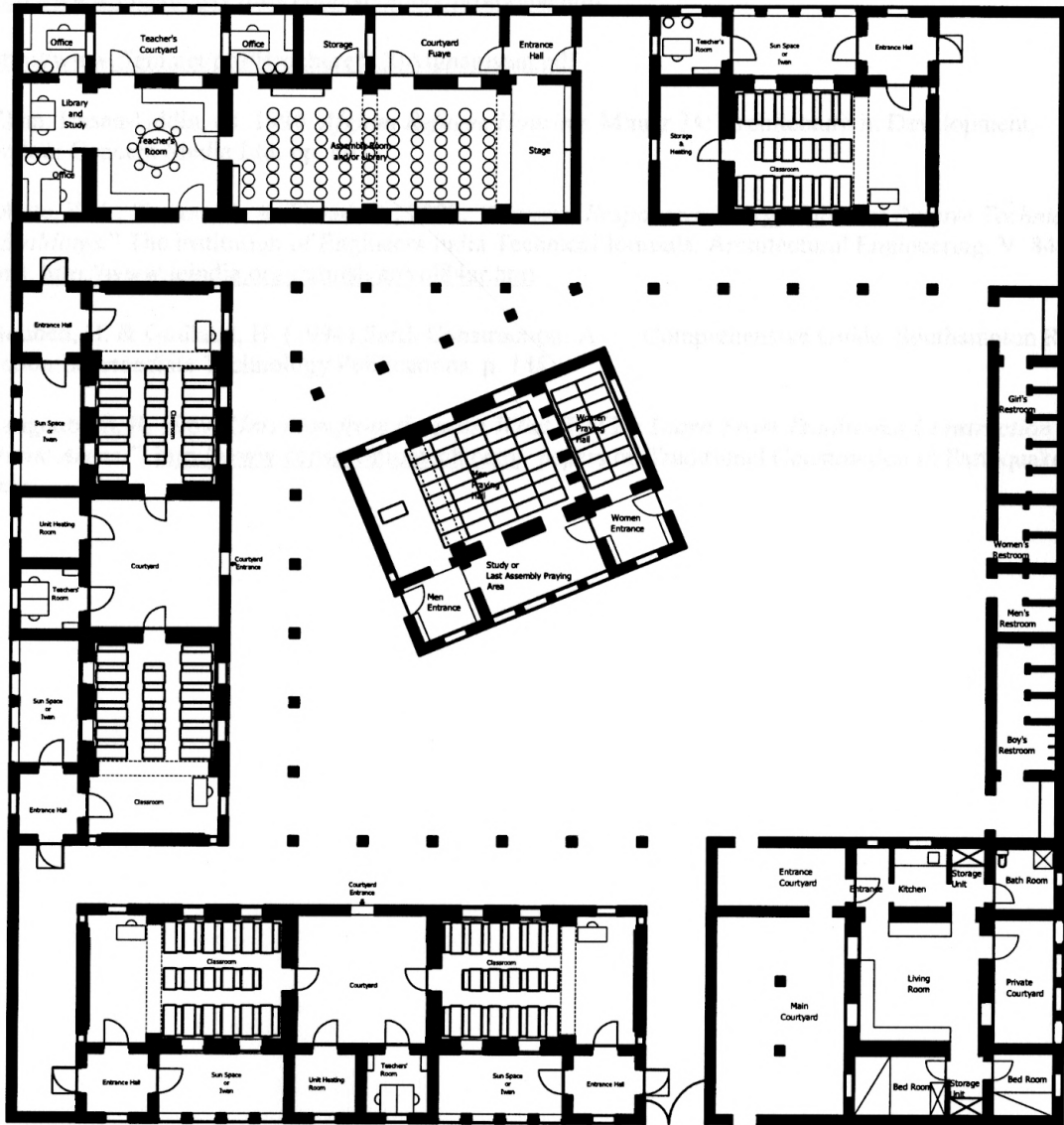

FIG. 70 Five Unit Arrangement

References:

¹ <http://www.pigeon.psy.tufts.edu/avc/huber/prototype.htm>

² <http://www.ffem.net/pdf/Brochure%20Afghanistan.pdf>

³ Khan, Hasan-Uddin, ed. 1990. *Afghan Refugee Housing*. Mimar 34: Architecture in Development. London: Concept Media Ltd. pp. 46

⁴ Dhote, K.K., Sharma, A. & Tiwari, R., 2003. "Climatic Responsive Energy Efficient Passive Techniques in Buildings." The institution of Engineers India Technical Journals: Architectural Engineering. V. 84 April. <http://www.ieindia.org/publish/ar/vol84ar.htm>

⁵ Houben, H. & Guillaud, H. (1994) *Earth Construction: A Comprehensive Guide*. Southampton Row, London: Intermediate Technology Publications. p. 148

⁶ Langenbach, R. 1989. "Intuition from the past: What We Can Learn From Traditional Construction in Seismic Areas." <http://www.conservationtech.com/> papers on Traditional Construction in Earthquake Areas

7 Structural Analysis and Architectural Design Refinement

This chapter provides information about the methodology of the structural application of the architectural design. It will outline the understanding of the software, what it is, how it works, and the stages of the application process with its findings. The chapter will not include all the steps, calculations, numbers that are used throughout the process. It is not the intention of this thesis to teach the software or all the structural issues, but clarify what has been done on what legitimate basis.

The study is applied to the main cell because of its size and importance. Its dimensions and properties were explained in Chapter 6.

7.1 Understanding RISA 3-D Software

RISA, Rapid Interactive Structural Analysis is a Windows operated engineering software by RISA Technologies of Foothill Ranch, California¹. The software is a general-purpose three-dimensional analysis and design program developed to make the definition, solution and modification of three-dimensional models as fast and easy as possible.

Various schools and structural engineers in the United States use RISA.

The software performs structural design in a three-step process. First, the existing model is redrawn according to capabilities of the RISA modeling using the RISA drawing tools. Second, the computer model is subjected to a series of pre-defined load conditions, such as dead, live, and lateral loads. Third, the problem is solved and the response of the structure according to the given loads is compared with the findings of different structural

factors of forces, stresses, etc. The third part can either show us a direct result using the previously given limits of failure for the model showing the structure is successful or not, or the maximum stresses that can be allowed on the model so we can compare with our model's maximum stresses.

7.2 Studying RISA 3-D and Geometry of the Design

Before starting the actual model, simple vaulted cross sections were studied in order to get acquainted with the software and to review the basics of structure. Several cross sections including a previous designed model were studied and examined. Two of these cross sections are shown in fig. 71 & 72.

These studies concluded that the lower the dome is the greater the structural forces and its distribution. The renderings also indicated that the shallow dome needed a thicker cross section to resist the same amount of force applied to the other cross section. This stage of the study showed how the different cross-sectional vaults work and what needs to be done to improve their strength.

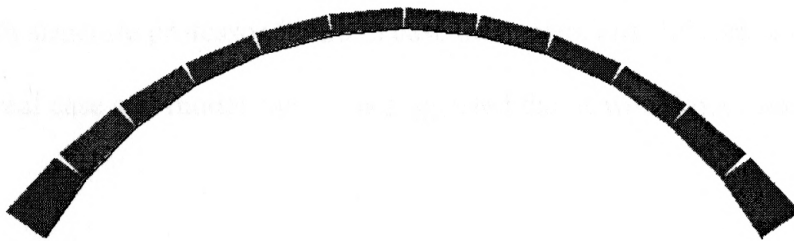

FIG. 71 SHALLOW VAULT, PREVIOUSLY DESIGNED MODEL

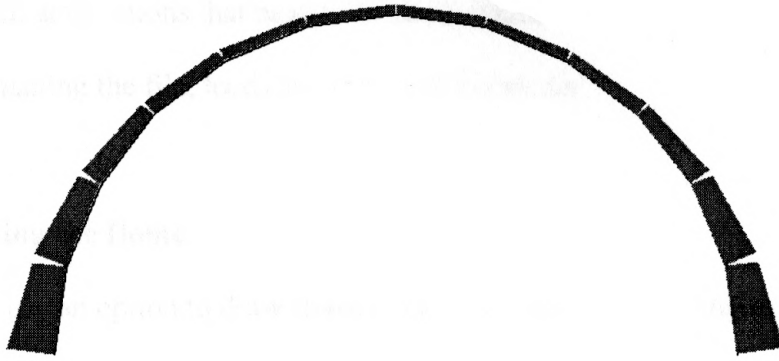

FIG. 72 STEEPER VAULT

7.3 Drawing the Structural Model

Drawing in RISA is little bit different than in AutoCAD. It is not as precise or detailed as AutoCAD yet it is not complicated to work with. It is about members, joints, or plates rather than lines, shapes, or objects. There are also defined shape generators such as a truss, frame, arc, and grid. that can be used to design the shapes by simply entering the required information. It is hard to draw complex or amorphous shapes with the software.

Since traditional Afghan vault construction does not involve clear, sharp shapes of molding process, it was decided to go with a close circular shape. This issue was discussed with structure professor Simic in case there were any differences of strength, between the real case and model case. It is suggested that it would not make much of difference.

Since the software provides a pre-defined shape tool for a vault, the walls and the dome were drawn separately on the same space and then connected together using shapes called rigid links so that the dome could distribute its load to the walls. Drawing the dome and the walls is explained in detail in the following sections. Before drawing any model, there

are many small applications that need to be done. These include defining the materials, thicknesses, naming the file, loads and their combinations.

7.3.1 Drawing the Dome

The software has an option to draw shapes (fig. 73) widely used in engineering. This helps to draw quicker and accurate forms. One of these is the circular arch generator (fig. 74) that helps to draw any type of arc, which can be used to generate a dome.

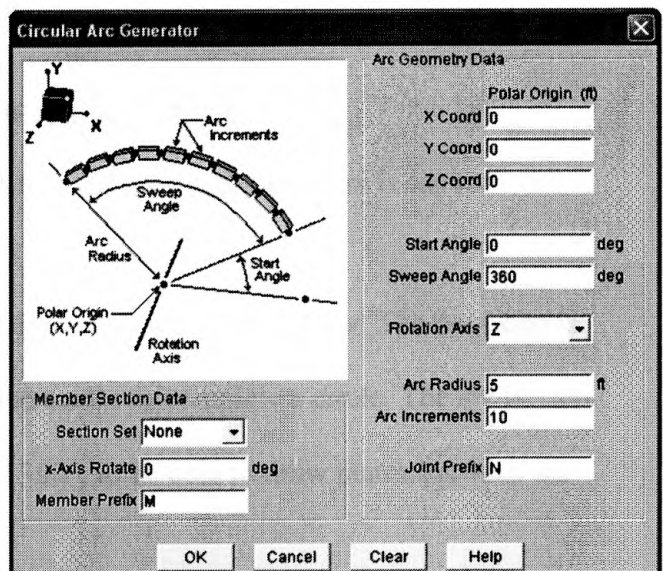
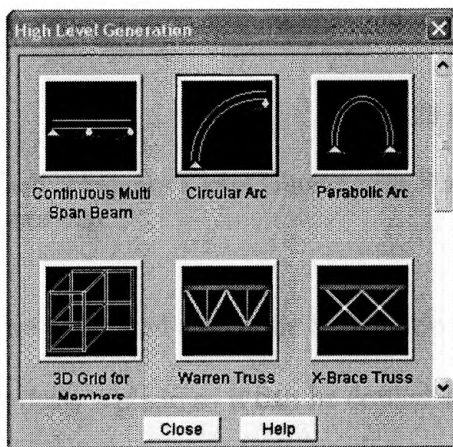

FIG. 73 SHAPE GENERATION TOOL

FIG. 74 CIRCULAR ARC GENERATOR

There is certain information about the arc that needs to be put into the arc generator in order to draw the dome. The required information can be seen in fig. 74. There are several ways to draw a dome shape. It can be drawn from a semi-circle arc and rotated or it can be drawn from half of a semi-circle arc and then rotated to complete a dome shape. In this project a half of a semi-circle arc (fig. 75) was drawn to form the dome shape.

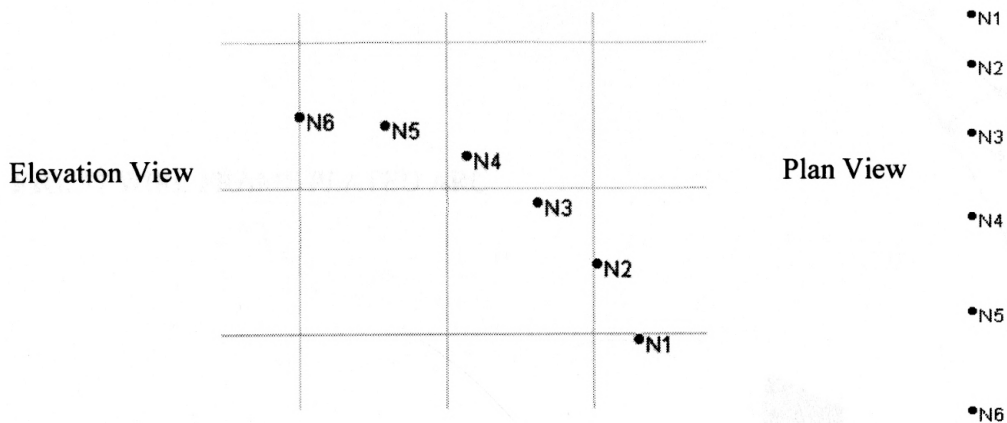

FIG. 75 HALF OF A SEMI-CIRCLE

Each dot shows a joint labeled with N and a number. Between each joint there is one arc increment.

The generated arc is one half-section of the dome that we want to draw. The next step is to draw a plane so it can be copied around the center to complete a circle. The arc is rotated (fig. 76) 15 degrees, which is $1/24$ of 360° , to be able to draw plates between the joints.

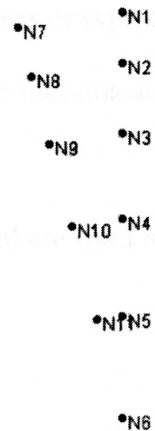

FIG. 76 15° ROTATED HALF OF A SEMI-CIRCLE

FIG. 77 WIRE FRAME PLATED ARC

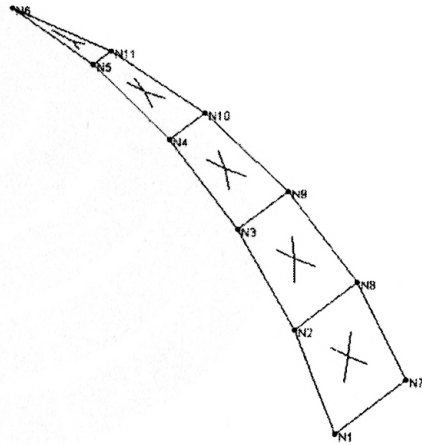
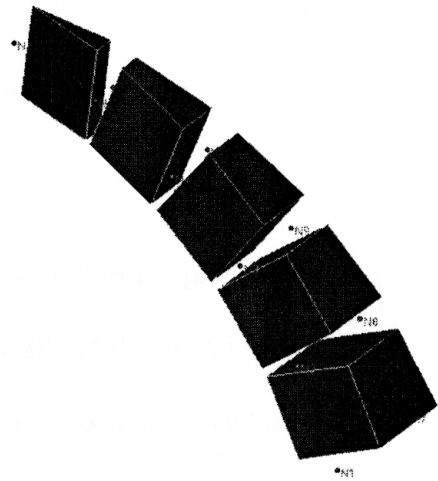

FIG. 78 80% RENDERED PLATED ARC



Once the rotation is complete the plates are drawn between each joints (fig. 77&78). Plates can be previously defined in terms of materiality and thicknesses. During the modeling, modifications can be done easily on the plate thicknesses or type of materiality. This helps to test the same model with different cross sections and materials.

After completing a portion of the dome, the rotation and copy tool are used to finalize the dome (fig. 79).

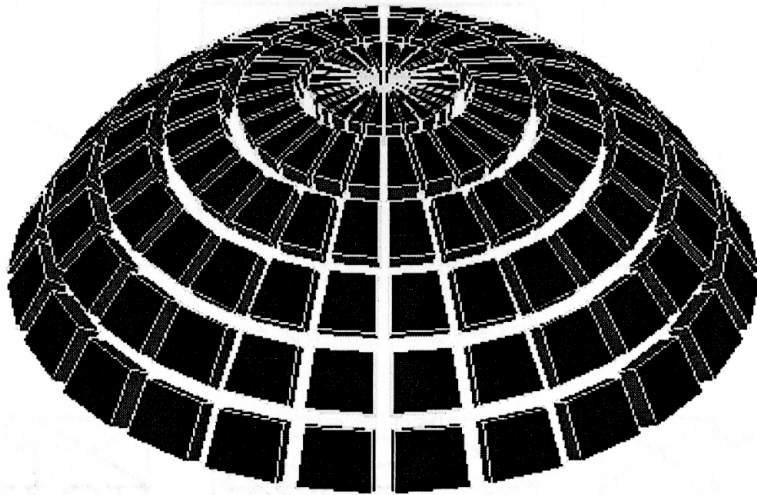

FIG. 79 COMPLETE DOME WITH 80% RENDERED

7.3.2 Drawing the Walls

Drawing a plane surface in the RISA requires a layout (fig. 80) of the plane surface, which is composed of a plate or plates. For this reason, walls of the model (Fig.81) are divided into plates (Fig.82) in order to draw accurately each opening placed on the wall.

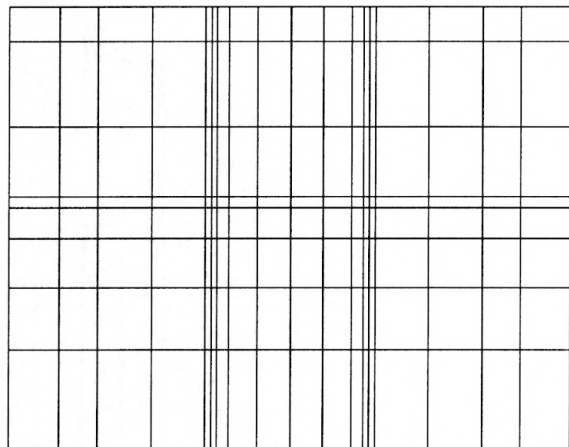

FIG. 80 TYPICAL LAYOUT OF A WALL

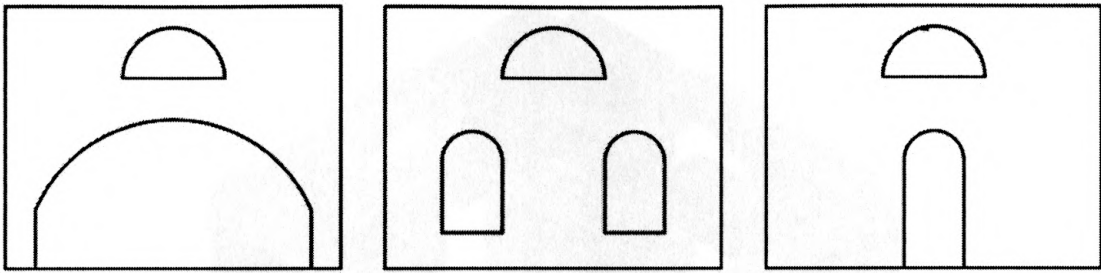

FIG. 81 WALLS OF THE MODEL

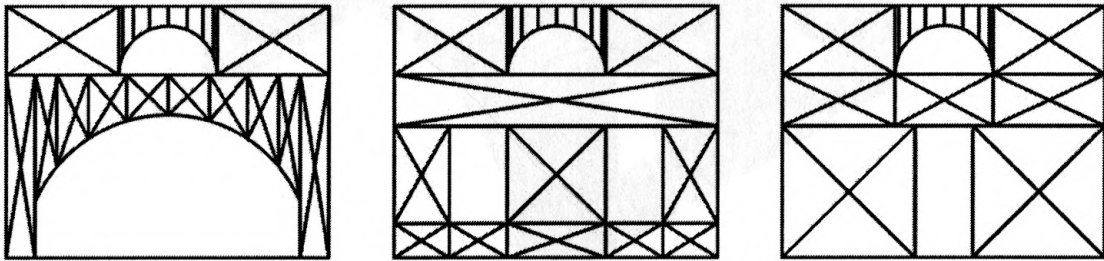

FIG. 82 WALLS OF THE MODEL DIVIDED INTO PLATES

The same plate tool used to draw the dome is used to draw the walls using the same features. Since there are some shared joints used to draw each wall (fig. 83), walls are automatically connected to each other. Once the drawing is complete it works as one system of walls (fig. 84).

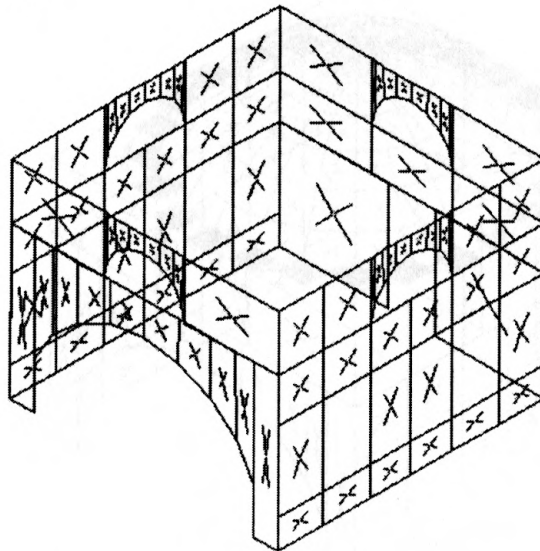

FIG. 83 WIRE FRAME OF THE WALLS

Each X represents a plate on the wall. Empty areas are the openings.

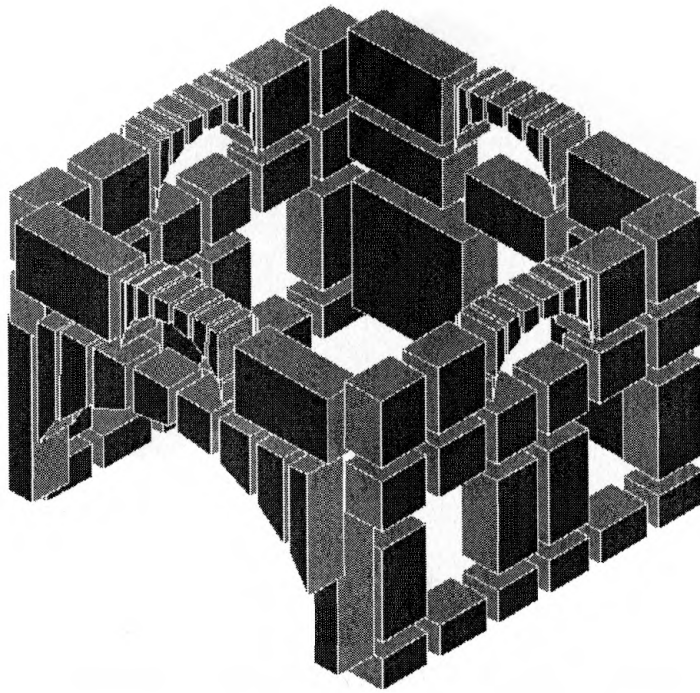

FIG. 84 80% RENDERED WALLS

After completing the dome and the walls, plates called rigid links (fig. 85) are put between the dome and the walls to connect them together (fig.86). This is done so that the weight of the dome could be distributed through the walls.

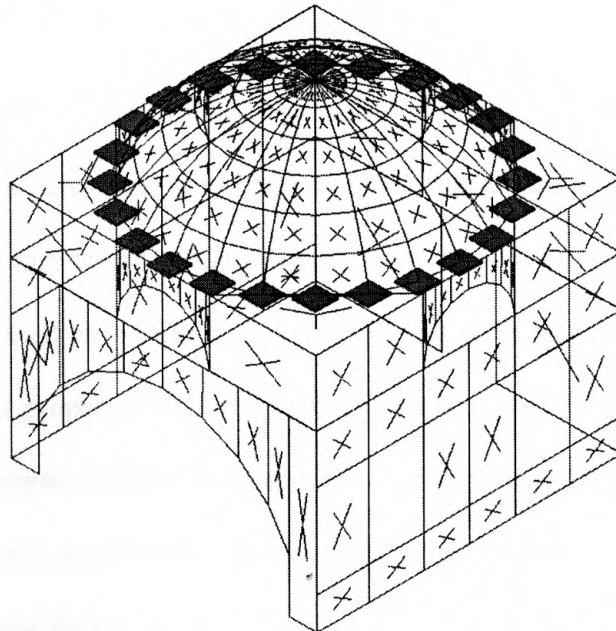

FIG. 85 RIGID LINKS BETWEEN THE DOME AND THE WALLS

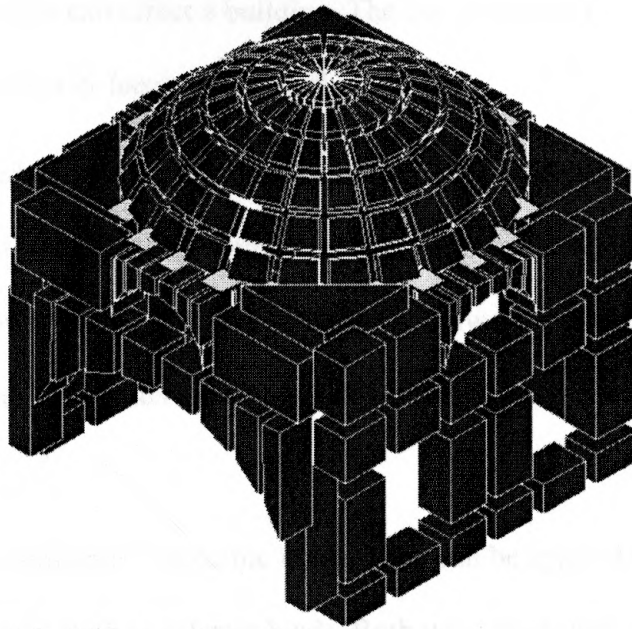

FIG. 86 COMPLETED MODEL, 80% RENDERED

7.4 Analyzing the Loads

The second part of the study involves identifying the material properties used for the construction, and defining the loads, such as gravity and lateral loads, applied to the model.

The software comes with numerous material properties commonly used in building construction, such as steel, concrete, wood, aluminum. Since the earth is not a common material in the contemporary construction market, an extensive literature review was done to find out the required properties both for CSSB and sun-dried mud brick. The review for these material properties shows a lot of differences in terms of numbers. A condensed table below shows the required properties by RISA using the optimum findings for both mud brick and CSSB.² The literature review findings are also added into the appendix section of the thesis.

There are different loads that can affect a building. The two main groups of loads that affect every building are *gravity loads* and *lateral loads*.

The gravity loads are predominantly static loads and they can be further distinguished as: *dead loads* and *live loads*. Dead loads are all permanent loads in the building and they are related to the materials own weight. The live loads are not always present in the building, so they are not permanent. Live loads analyzed in this building are the service load and the snow load.

The lateral loads are predominantly dynamic loads. They can be applied loads, such as wind loads, or inertial loads, such as seismic loads. Both wind loads and seismic loads were analyzed in this building. Due to absence of Afghan building codes, the Uniform Building Code (UBC) was used for all calculations and structural design.

| | CSSB | Mud Brick |
|---------------------------------------|--------------|--------------|
| 28-day compressive strength | 290-725 psi | ≅ 290 psi |
| 28-day tensile strength | 145-290 psi | 0-77.5 psi |
| 28-day bending test | 145-290 psi | ≅ 77.5 psi |
| 28-day shear test | 145-290 psi | ≅ 77.5 psi |
| poisson's ratio | 0.15-0.35 | ≅ 0.5 |
| young modulus (modulus of elasticity) | 102-1020 ksi | 58-116 ksi |
| apparent bulk density | 106-137 pcf | 74.9-106 pcf |

7.4.1 Dead Load Analysis

The dead load in this building is the material self-weight. While the dead load is applied to the dome only, for its design against gravity failure, the software takes into account the

self-weight of all the walls during the seismic design.

The live load applied to the dome is a human and service load that could occur during possible roof repairs. The live load used on the model is 16 psf for an arch or a dome with rise less than one-eighth of span and the total surface area between 201 to 600 square feet (Schueller, p. 79). Besides the live load, the self-weight of the dome, which is related to the materials density and the thickness of the dome, is added to the total dead load. For a worse case scenario, if we use the highest possible density for CSSB, which is 137 pcf and times this with 8/12 because the dome is 8-inch thick, it would be $\cong 92$ psf. if the thickness were 4-inch or 4/12, the load would be $\cong 46$ psf. In the case of mud brick, which has a maximum density of 106 pcf, we simply proportion the density of the materials and times the result with the CSSB's previous results. This gives $106/137 \times 92$ or 46 and the result would be for 4-inch thick dome $\cong 36$ psf and for 8-inch dome $\cong 72$ psf.



FIG. 87 1828 FIVE-STORY RAMMED EARTH BUILDING IN WEILBURG, GERMANY

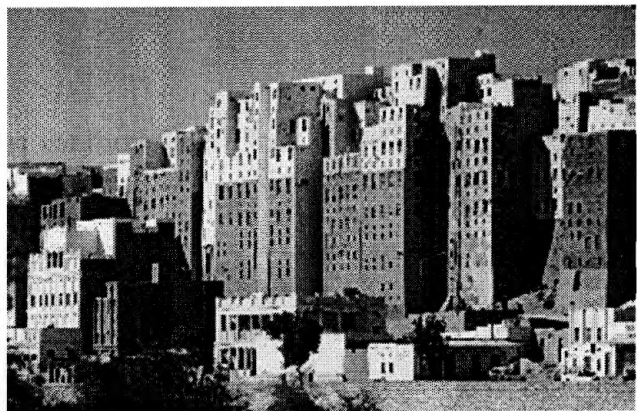

FIG. 88 SHIBAM, WADI HADHRAMAUT, YEMEN

The numbers found above for live load and dome self-weight are used as dead load in the model for simulation

7.4.2 Snow Load Analysis

There has been a record of 177 inches of snow³ in North Salang region of Afghanistan, which is at an elevation of 11,043 feet. Figure 89 shows the maximum snow depth of Afghanistan includes the data of 1956 to 1983. We can see only North Salang region of Afghanistan gets over 100 inches of snow. Since one inch of snow weighs approximately 0.2 to 1 psf depending on the moisture content (Schueller, p. 80), snow load will be considered 100 psf for the beginning of the calculation. Having a slope roof gives a reduction factor, which can be calculated using the formula of:

$$p_s = \left(1 - \frac{\theta - 30^\circ}{40}\right) p_g \quad (\text{Schueller, p. 81})$$

This is a formula used if the roof is over 30°. The roof in the design has a slope of 33°.

The abbreviations stand for:

Ps: sloped-roof snow load

Pg: ground snow load

Snow load that was used in the model after the formula is 93 psf, which is still an extreme condition.

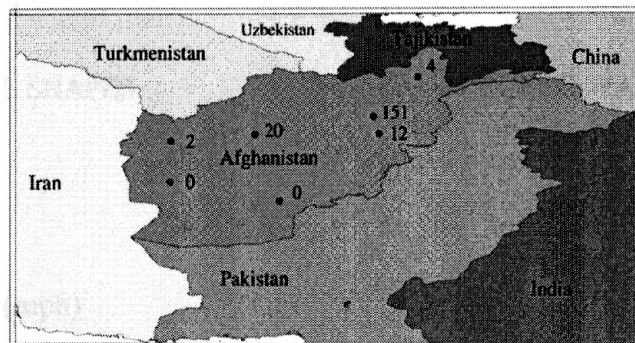

FIG. 89 MARCH MAXIMUM SNOW DEPTH- INCHES IN AFGHANISTAN

7.4.3 Wind Load Analysis

During the period of 1961-1983, a wind speed of 98 mph is recorded in February at Farah, in western Afghanistan⁴. From this point, the wind speed of 100 mph is considered in the model. The formula used to find the wind load is:

$$p = C_e C_q q_s I \text{ (psf)} \text{ (Schueller, p. 322)}$$

The abbreviations stand for:

P: wind pressure psf

C_e: combined height, exposure, and gust factor. If the building is located flat and open terrain which most likely a good case for Afghanistan the factor is various from 1.06 to 2.19. For the worse case scenario 2.19 will be chosen.

C_q: pressure coefficient. C_q changes according to the shape of the roof and the direction of the wind. For the dome shapes and wall (fig. 90) the value of the C_q is given as a figure below.

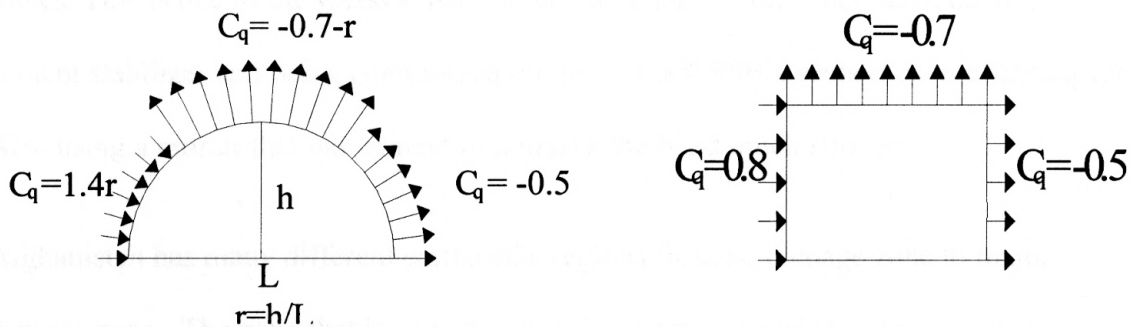

FIG. 90 C_q FOR DOME SHAPES

C_q FOR WALLS

q_s: stagnation pressure

$$q_s = 0.00256V^2$$

V is the speed of wind (mph)

I: importance factor. In this case 1 is appropriate.

qs: 0.00256×100^2

qs: 25.6 psf

Also the r would be 1/3 according to the dimension of the design. With the information given above wind load is used on the model is (fig. 91).

| | | |
|----------------------|------------------------------|-------------------------------|
| <u>Windward dome</u> | <u>Outward dome top part</u> | <u>Outward dome side part</u> |
| $p \cong 25.9$ psf | $p \cong 57.7$ psf | $p \cong 28$ psf |

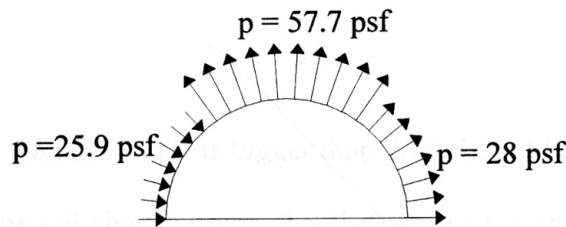

FIG. 91 WIND LOAD ACCORDING TO THE SHAPE OF THE DOME

7.4.4 Earthquake Load Analysis

Earthquake is the most important part of the structural study. Earth bricks have a good capability of working against gravity loads, but have very weak resistance against lateral forces. This is one of the weakest parts of the material. On the other hand, having a cement stabilizer and being compressed improves the CSSB's properties in every aspect. Also using a mortar that has cement in it makes the bond much stronger.

Afghanistan has many different earthquake regions from no damage zone to major damage zone. The zone that is considered in this study is a major earthquake zone.

All the co-efficiencies used in the formula are taken according to a worst case scenario.

The formula to calculate the seismic force is:

$$V = \frac{ZIC}{R_w} W \quad (\text{Schueller, pp. 335-337})$$

V: total lateral seismic force, or shear at the base

W: total dead load

Z: seismic zone factor. For the greatest zones the factor is 0.4

I: the importance factor. For the model, 1 is the appropriate number.

C: numerical coefficient, often called the design response spectrum value. It has a formula:

$$C = \frac{1.25S}{T^{2/3}} \leq 2.75$$

C cannot be bigger than 2.75. If it is bigger than 2.75 should be taken into account.

S: site coefficient for soil characteristic. 2 is the worse site condition co efficiency.

T: fundamental period of vibration of the structure in the direction under consideration

It has a formula:

$$T = C_t h_n^{3/4}$$

Hn: building height (ft) above base

Ct: moment-resisting frames. 0.02 is used for model.

Rw: numerical coefficient. 6 is used for the model.

The calculation would be:

$$\begin{aligned} T &= 21 \text{ ft (6.4m)}^{3/4} \times 0.02 \\ &= 1.25 \times 0.02 \\ &= 0.025 \end{aligned}$$

$$\begin{aligned} C &= 1.25 \times 2 / 0.025^{2/3} \\ &= 2.5 / 0.087 \\ &= 28.73 \end{aligned}$$

2.75 is used since the C is bigger than 2.75

W: total dead load of the building according to 8-inch thick dome and 24-inch thick wall is 292883 pounds. According to different situations this number is used to make proportional calculations. Also the earthquake force, depends on the direction of the hit, is split into pieces according to the surface area of the walls that touches the ground.

7.5 Conclusion

The impacts of these load analysis was simulated and studied with the software for both sun dried mud brick and CSSB construction (FIG. 93 & 94). Each of the figures has its explanation underneath it. In addition to these loads, different cross sectional profiles in terms of the proportioning of the domed roof and the thickness of the walls (Fig. 92) was studied at the same time with the structural model.

The stresses studied upon loading analysis are:

Sigma, 1-2 Stress: This is the maximum and minimum normal stress. Tensile and compressive stresses are called normal stresses. Sigma positive is the tensile stress and sigma negative is the compressive stress.

The Tau Maximum Stress: This is the maximum shear stress

The Von Mises Stress: This is a combination of the principal stresses and represents the maximum energy of distortion within the element.

There are two types of results that the software can present. Through a graphical means, which is color coded with contours, and via spreadsheet, which has the all stresses applied for each of the joints. There can be also animations to see deflections. The results that are obtained are compared with the material's properties to see if there is any

problem.

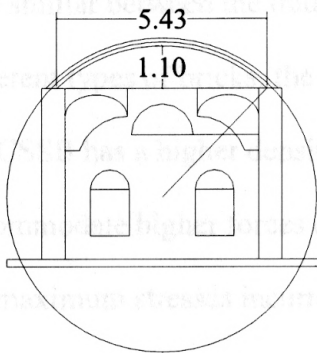

Model 1:

$$\text{Proportion: } 1.10/5.43 = 20/100$$

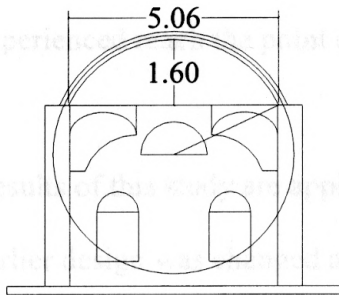

Model 2

$$\text{Proportion: } 1.60/5.06 = 31/100$$

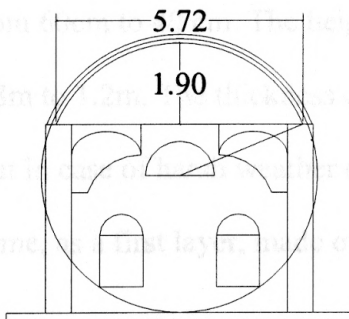

Model 3

$$\text{Proportion: } 1.90/5.72 = 33/100$$

FIG. 92 CASE STUDY MODELS: PROPORTION OF HEIGHT TO BREADTH OF THE DOME

There is a direct relationship between the mass of the building and the earthquake force experienced by the building. The force of the earthquake will vary depending upon the density of the brick and the thickness of the wall sections, which determines the overall mass of the building. Given the same density of material, a thicker wall will receive a

higher earthquake force than a thinner one. However, because of a higher resistance that a thicker wall provides, both of the results will be close to each other. This relationship is also similar between the traditional mud brick construction and CSSB. In the case of different types of bricks, the results will vary according to their properties. Even though the CSSB has a higher density and receives higher amounts of earthquake force, it can accommodate higher forces due to its higher stress tolerances. The analysis indicates that for maximum stresses incurred in an earthquake, the stresses in CSSB are considerably lower than the maximum allowed whereas, for mud brick, the maximum stresses experienced reach the point of possible structural failure.

Results of this study are applied to the architectural design. The dome section of the earlier design was changed after this study. The earlier design had a shallower dome section. The wall thicknesses of the surrounding cells of the main space were changed from 60cm to 40 cm. The height of the wall that works as a ring beam is raised from 0.8m to 1.2m. The thickness of the dome was reduced to 10 cm. Also, it can be suggested that in case of harsh weather conditions due to low temperature, there can be a second dome, as a first layer, made out of sun-dried mud brick to reduce cost.

It was not the intention of this study to test larger spans of dome structures due to the necessity of the architectural design.

FIG. 93 TRADITIONAL MUD BRICK STRUCTURAL ANALYSIS

Sigma (Tensile & Compression) Stresses created by a severe earthquake in region four

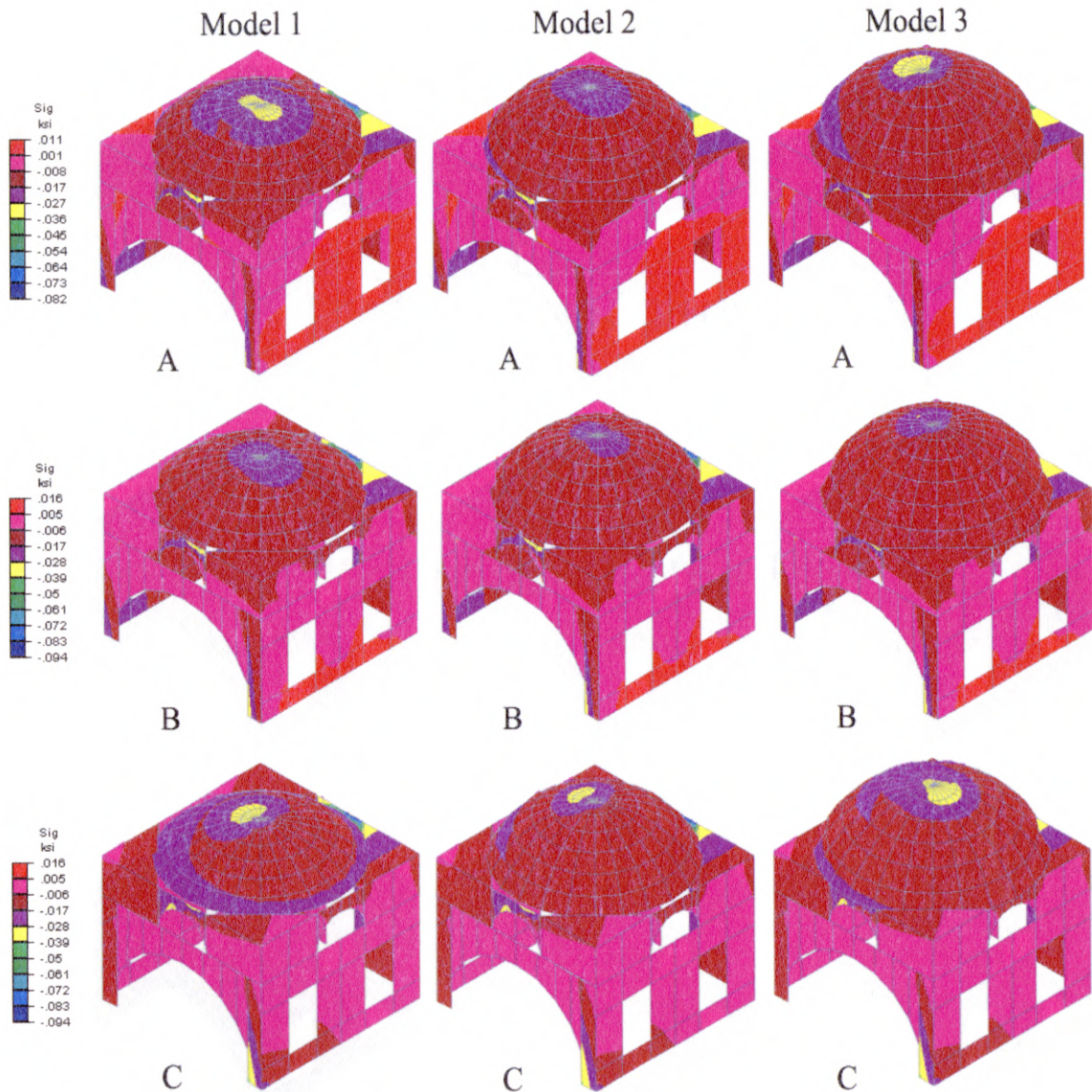

All Domes are 10 cm ~ 4 inch in thickness

A: 60 cm~24 inch wall, B: 40 cm ~ 16 inch wall, C: 20 cm ~ 8 inch wall

The simulations above show no indication of failure in terms of tensile and compressive stresses. The three vertical stress scales show a close relationship of stresses because of the proportional decrease of earthquake forces caused by the decreasing of the wall thickness. Overall bigger tensile stresses occur on the shallow dome.

Tau (Shear) Stresses created by a severe earthquake in region four

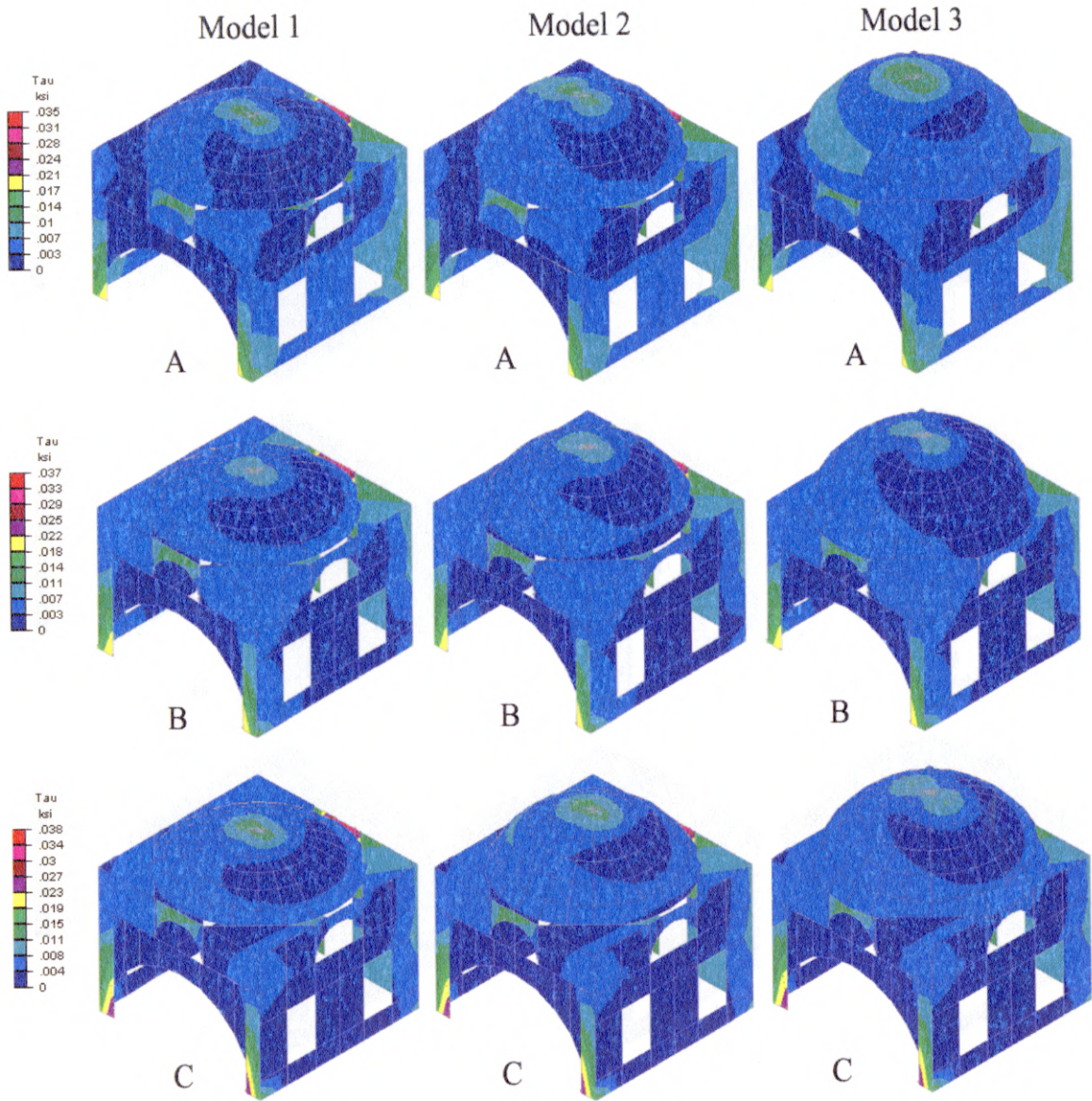

The simulations above show no failure in terms of shear stresses. Highest numbers are half the allowable stresses. The roof domes have little difference in comparison to each other.

Von Mises (Maximum) Stresses created by a severe earthquake in region four

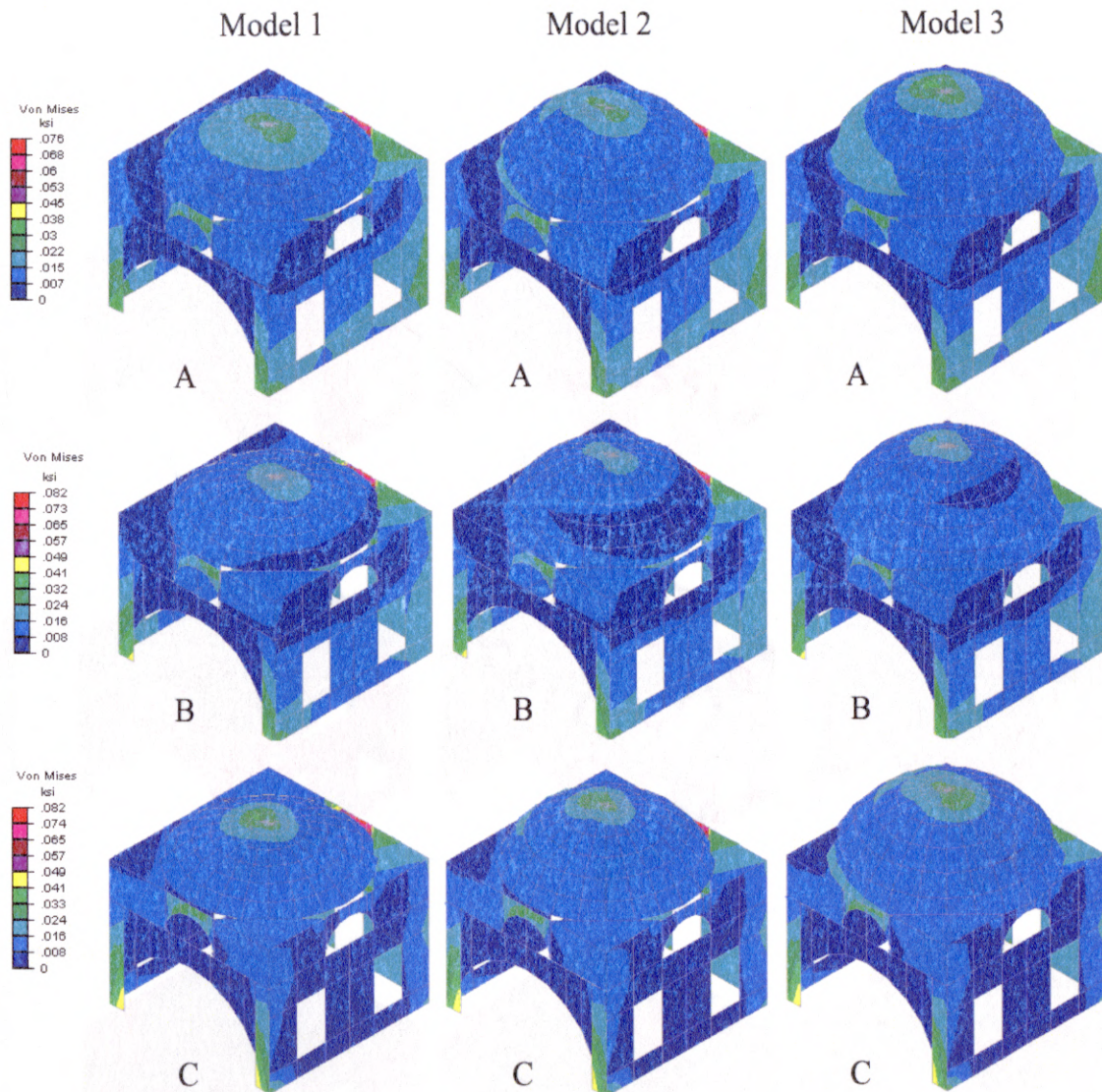

The simulations above show that the stresses are slightly over the allowable stresses that are given on page 102. A simulation with an 80 cm wall gave a better performance for the principal stresses. Under the condition of the maximum (principal) stresses the conclusion can be made that for the resistance of the maximum stresses traditional mud brick construction requires thicker wall sections than 60 cm (24 inch).

FIG. 94 COMPRESSED SOIL CEMENT BLOCK STRUCTURAL ANALYSIS

Sigma (Tensile and Compression) Stresses created by a severe earthquake in region four

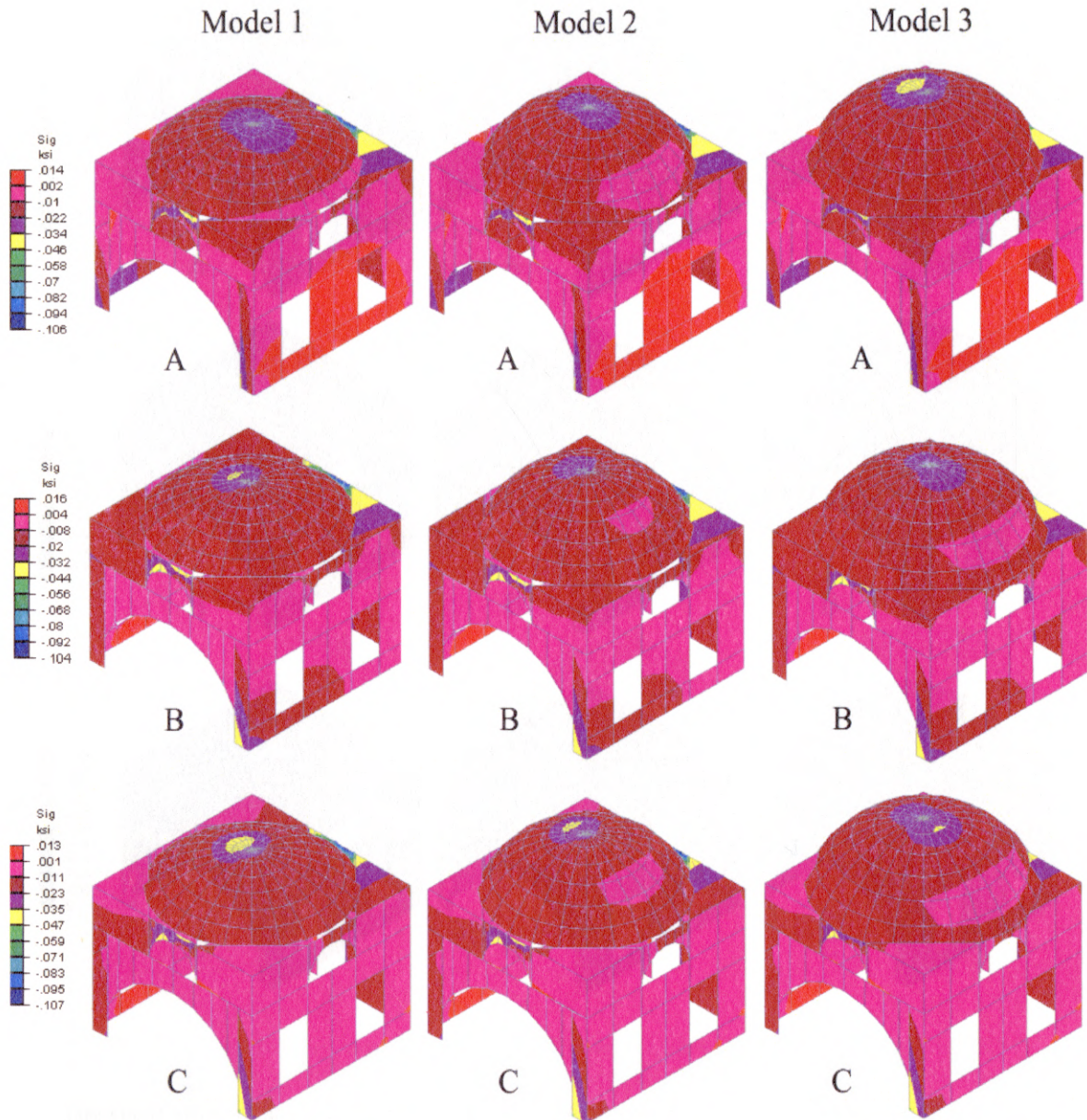

The stresses above are much lower than the allowable stresses and they are slightly over the values of the traditional bricks. This shows much better performance against traditional brick due to the comparison of the results and the allowable stresses. The shallow roof gets a larger stress than the other roofs.

Tau (Shear) Stresses created by a severe earthquake in region four

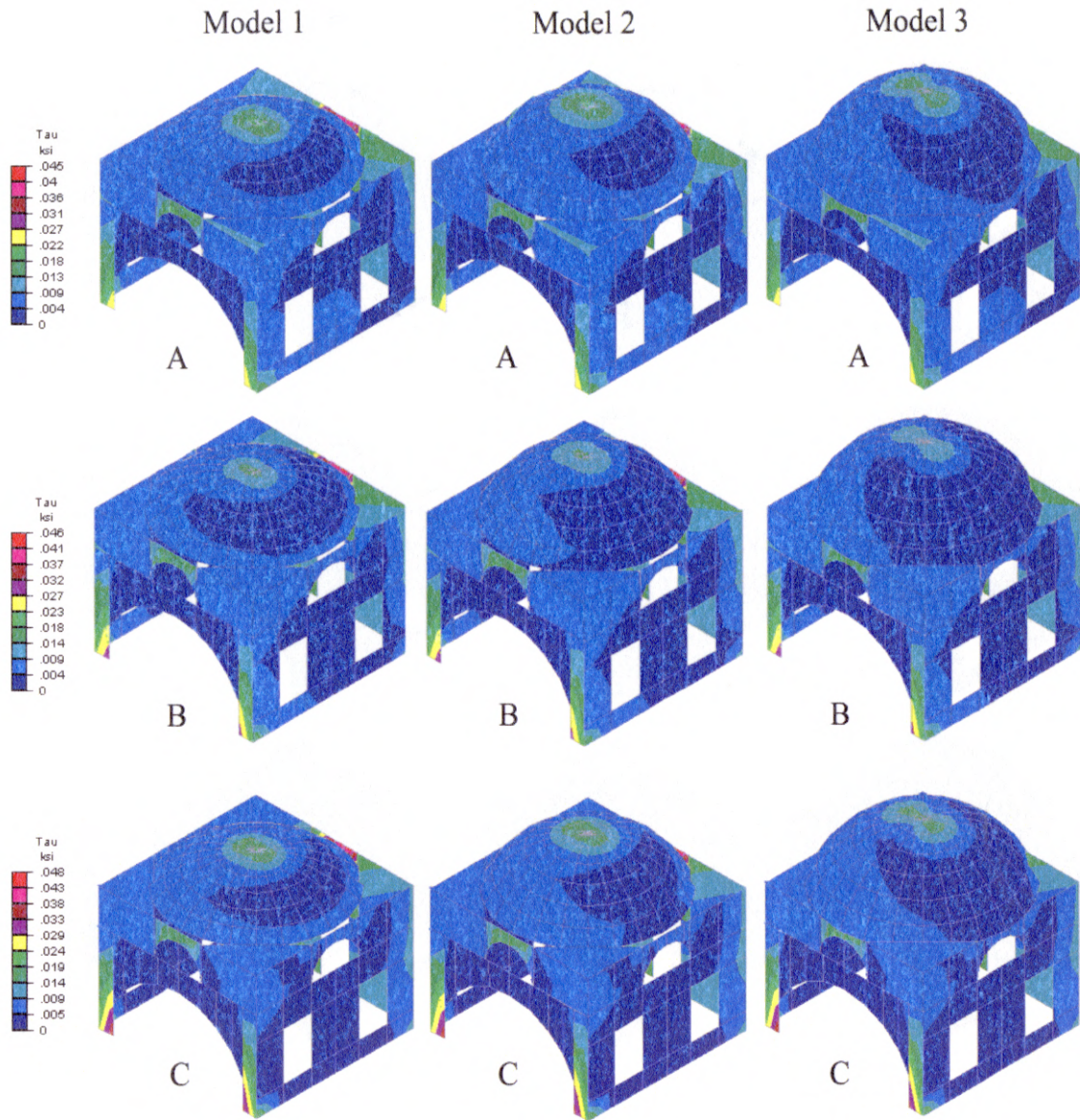

The shear stresses are six times less than the allowable stresses while on the other hand the traditional model was two times lower than the allowable stresses. None of the models show any structural problems. The model 1 roof gets a larger stress than the other two models, but the differences are structurally insignificant.

Von Mises (Maximum) Stresses created by a severe earthquake in region four

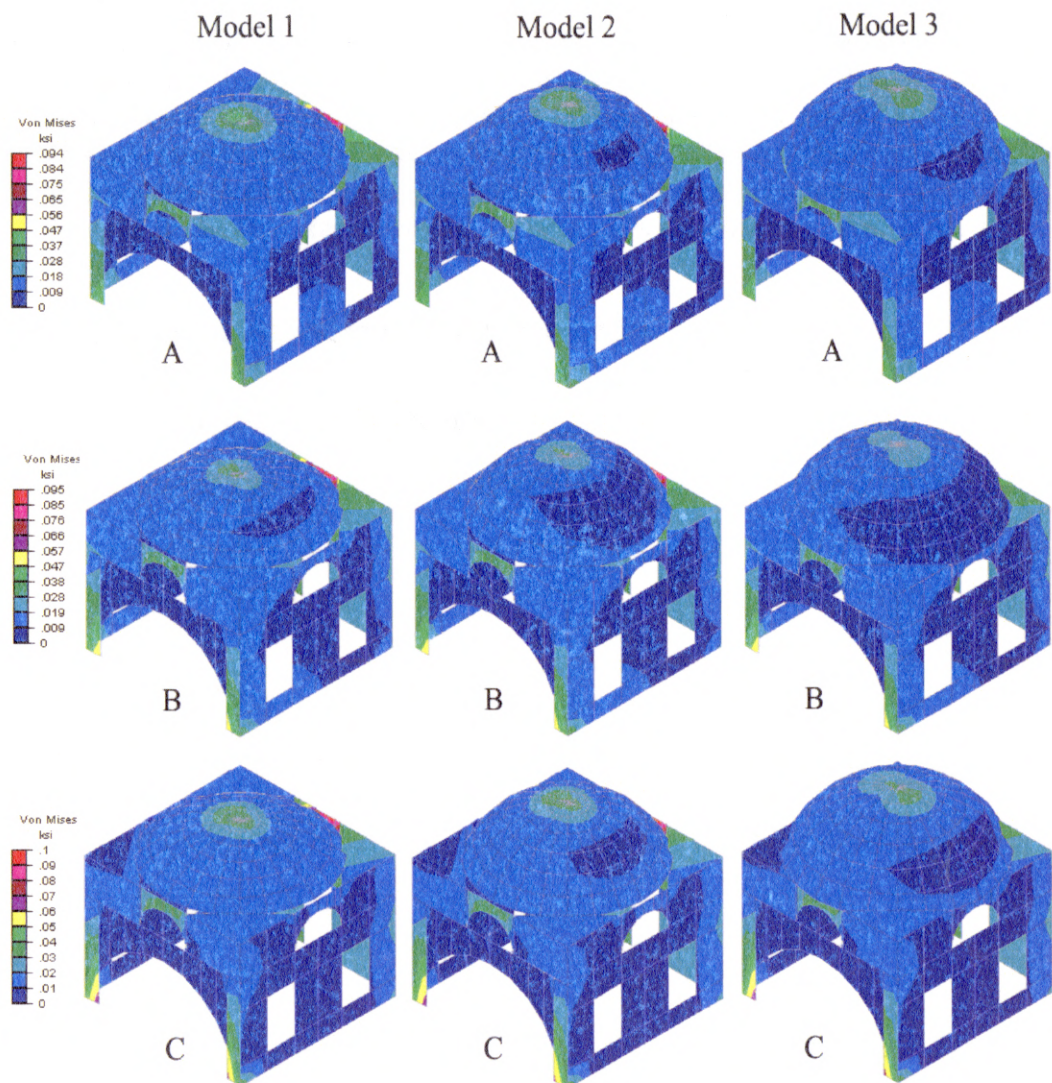

The principal stresses are again lower than the lowest maximum allowable stresses. In comparison, the principal stresses in traditional mud brick, are stressed to possible failure. All model 1 roofs show larger stresses than the other models, but the difference is insignificant.

References

¹ <http://www.risatech.com/>

² H.Houben and H. Guillaud, *Earth Construction: a comprehensive guide* (CRATerre: IT Publications,1994), The Modulus of Elasticity of mud brick comes from B.Jaishi,.W Ren, Z. Zong, and P. Maskey, *Dynamic and Seismic Performance of Old Multi-Tiered Temples in Nepal*. [http://bridge.fzu.edu.cn/English/\(2003\)](http://bridge.fzu.edu.cn/English/(2003)), Data for sandy soil brick 28 day compressive strength comes from M.Catton, "Soil Cement Technology- A Resume." *Journal of the PCA Research and Development laboratories*. vol. 4, no. 1, (1962), pp.13-21.

³ <http://www.ncdc.noaa.gov/oa/climate/research/afghan/overview.html>

⁴ <http://www.ncdc.noaa.gov/oa/climate/research/afghan/overview.html>

8 CONCLUSIONS

The recommendations and results of this thesis can be summarized into three categories: design, structure, and material.

8.1 Design

The flexibility of the cells and clusters represented in the design allow it to be arranged for different functions. Therefore this adaptation of cellular clusters into different programmatic needs is important to compose different sizes of schools or other community structures. Use of clusters and cells in a certain way promotes different functional and enjoyable outdoor spaces, such as courtyards, gardens, and arcades. The use of clusters also increases the construction speed due to frequent applications of the same details and educates large numbers of unskilled labor due to its repeated phases that provides the same exercises. Use of CSSB in the design makes the spaces more hygienic and better quality than traditional sun dried bricks. The appearance of facades also looks more finished and professional.

Designing is a continuous action of thinking and it has to be stopped in order to reach a conclusion. It is believed that within the given and agreed time, the design of this thesis has improved and accomplishes its objectives. However, there is no exact truth in architecture and opinions can be change from one person to another. So, these prototypes of spaces purposed by this thesis are open to criticisms and it surely will be. Therefore it is important and also part of the conclusion to have these kinds of criticisms in order to improve the design.

8.2 Structure

The structural analysis showed that the architectural design of the main cell is much safer with the use of CSSB rather than traditional mud brick. Simulations showed that it is possible to use thinner walls and have a larger span dome. With the use of CSSB, the ratio of the dome, height/span, can be smaller than the traditional mud brick.

Simulations also helped to see where the major forces occur in the structure. With the help of this information these places can be built much stronger by paying more attention to the building process and increasing the cement ratio in the mortar can help to the increase strength.

This thesis is not involved with real case model simulations. It can be suggested as a further research to build a model with 1/1, 1/2 or 1/4 scale of the design with real CSSB and right construction details to apply earthquake tests. It can also be suggested that the use of different structural software to compare the results would be useful.

A study of real case seismic model analysis for a wall made out of CSSB as an outer layer and traditional mud brick as an inner layer can be useful to observe how these two types of blocks behave as one unit during an earthquake. If the results were satisfactory one layer of CSSB and one layer of traditional mud brick can be sufficient enough to build the prototypes.

It can be concluded that the simulations run on structure shows profound distinction between CSSB and traditional mud bricks in the favor of CSSB and also structural analysis of the traditional brick construction confirmed the very marginal resistance to seismic loads.

8.3 Material

Previous limited research on high-density compressed stabilized soil-blocks shows that the blocks seem reasonable as low-cost building materials.¹ It requires less energy than other conventional materials yet it is strong enough to resist any weather conditions and seismic forces. It is a material that can be manufactured on site with locally available materials. Research still continues to increase the strength and durability of the material and to better understand the nature of CSSB.

It is important to work with the right amount of soil and water to produce stronger blocks. Extra attention must also be paid during the making process and curing phases. These are the important issues that most of the papers and researchers agree on.

The literature on the Cinva-Ram is very limited and the impacts of the Cinva-Ram with different press handle designs are not well known. Research can be conducted to improve the compression force that is applied on the Cinva-Ram. Various sizes of handles can be tested to see if the impact increases or the force that is transferred through the mechanism can be altered differently to increase the final force applied

on the material. Increasing power in compaction will increase the density; therefore the strength and durability will increase, too. This kind of research can be useful to keep the cost of compaction still low and increase the quality of the bricks.

Finally, the use of CSSB with current and future research is likely to increase as a low-cost building material in developing countries.

It is important to unify the people in Afghanistan with today's conditions. This can be done by conserving the culture and building tradition through the promotion of earth based building techniques. Together with religion, earth construction is one of the common standards of life in Afghanistan. Even though the advantages of CSSB against traditional mud bricks are explicit, the method needs to be promoted for countrywide acceptance. Governments should be involved introducing and financing the use of CSSB. This thesis and many other projects are believed to be useful in this manner. One of the outcomes of this thesis is a paper and publication that is submitted for international conference². The paper will help to introduce the design, outline the problems and solutions, and raise questions about CSSB within an international academic audience.

References:

¹ Montgomery, D.E. & Thomas, T.H, 2001. *Minimizing the Cement Requirement of Stabilized soil Block Walling*. Department Technology Unit, School of Engineering at Warrick University, Coventry, UK.

² Watts, D., J. & Yoldas, C., 2004. Re-Conceiving Afghan Cellular Architecture for the Reconstruction of Rural Schools. 2004 Conference: Sharjah/ Dubai. *Post Traditional Environments in a Post Global World*. By IASTE (International Association for the Study of Traditional Environments.)

BIBLIOGRAPY

Afghanistan:

- Azizi, M. (1980). "A Preliminary Study of Traditional Building Crafts in Kabul, Afghanistan" Royal Danish Academy of Fine Arts, Department of Building Restoration.
- Hallet, S.I & Samizay, R. (1980). *Traditional Architecture of Afghanistan*. New York: Garland STPM Press.
- Kazimee, A. B., & McQuillan, J. (2002). *Living Traditions of the Afghan Courtyard and Aiwan*. Traditional Dwellings and Settlements Review, v.XII, No: II, Spring, pp.23-34.
- Leslie, J. (1991). *Afghanistan: Utopian Upgrading*. Mimar 41: Architecture in Development. London: Concept Media. pp. 15-17.
- Scherrer, O., 1990. Afghan Refugee Housing. Mimar 34: Architecture in Development, London, Concept Media Ltd. pp. 43-50
- Sibtain, S.N. (1981). To Build a Village. *Afghanistan Journal*. Jg 8, Heft 3, pp. 79-89.
- Szabo, A. & Barfield, T.J. (1991). *Afghanistan: An Indigenous Domestic Architecture*. Austin, Texas: University of Texas Press.
- Watts, D.J. (1981). Recurrent Patterns in Traditional Afghan Settlements. *Afghan Journal* Vol. 8, No. 2 first quarter pp.66-72
- Watts, D.J & Yoldas, C. (2005). "Re-Conceiving Afghan Cellular Architecture for the Reconstruction of Rural Schools." Traditional Dwellings and Settlements Working Paper Series: vol. 168. Center for Environmental Design Research, University of California, Berkeley, Forth Coming.

Earth Construction:

- Baghdadi, Z. A., & Shihata, S. A. (2001). *Long-Term Strength and Durability of Soil Cement*. Journal of Materials in Civil Engineering. Vol. 13, No. 3 May/June, pp. 161-165.
- Bourdon, D. (1995). *Designing the Earth: the Human Impulse To Shape nature*. New York: Harry N. Abrams, Inc.
- Bourgeois, J-L. (1983). *Spectacular Vernacular: A New Appreciation of Traditional*

Desert Architecture. Salt Lake City: Gibbs M. Smith Inc.

- Choobbasti, A. J. & Bagherpour, I. (2003). *Stabilization of Fine-grained Soils by Adding Microsilica and Lime or Microsilica and Cement.* The Electronic Journal of Geotechnical Engineering, Vol. 8, Bundle B. www.ejge.com
- Cotton, M. D. (1962). *Soil-Cement Technology-A Resume.* Journal of the PCA Research and Development Laboratories, Vol. 4, No. 1, 13-21, January.
- Dethier, J. (1981). *Down to Earth: Adobe Architecture:an Old Idea, a New Future.* Facts On File, Inc. New York, USA.
- Easton, D. (1996). *The Rammed Earth House.* Vermont:Chelsea Green Publishing Company.
- Elizabeth, L. & Adams, C. (ed.) (2000). *Alternative Construction: Contemporary Natural Building Methods.* New York: John Wiley & Sons.
- Erdik, M.O. (ed) (1987). *Middle east and Mediterranean regional conference: on Earthen and Low-Strength Masonry Buildings in Seismic Areas.* Middle East Technical University, Ankara.
- Gooding, D.E. (1993). *Quasi-Static Compression Forming of Stabilised Soil-Cement Building Blocks.* Working Paper No. 40, Development Technology Unit, University of Warwick. Coventry, England.
- Gooding, D.E. (1993). *Soil Testing for Soil-Cement Block Preparation.* Working Paper No. 38. Development Technology Unit, University of Warwick, Coventry, England.
- Gooding, D.E. (1994). *Improved Processes for the Production Soil-Cement Building Blocks.* PhD Thesis. University of Warwick. Coventry, England.
- Gooding, D.E., Thomas, T.H. (1995). *The Potential of Cement Stabilised Building Blocks as an Urban Building Material in Developing Countries.* Working Paper No. 44. Development Technology Unit. University of Warwick. Coventry, England.
- Guilaud, H., Joffroy, T & Odul, P. (1995). *Compressed Earth Blocks: Volume II, Manual of design and construction.* German Appropriate Technology Exchange (GATE) Publications. Eschborn, Germany.
- Heathcore, K. A. & Moor, G. J. (2000). *Durability of Cement Stabilized Earth Walls.*

Fifth CANMet/ ACI International Conference on Durability of Concrete,
Barcelona, Spain.

- Houben, H. & Guillaud, H. (1994) *Earth Construction: A Comprehensive Guide*. Southampton Row, London: Intermediate Technology Publications.
- Joy, R. (2002). *Rick Joy: Desert Works*. Princeton Architectural Press, New York, USA.
- Kapfinger, O. (2001). *Rammed Earth*. Basel Switzerland; Birkhäuser- Publishers for Architecture.
- Kerali, A.G. (2001). *Durability of Compressed and Cement-Stabilized Building Blocks*. Unpublished Doctoral Dissertation, University of Warmick, Warmick, England.
- King, B. (1996). *Buildings of Earth and Straw*. Sausalito, California: Ecological Design Press.
- Khalili, N. (2003). *Ceramic Houses & Earth Architecture: How to Build Your Own*. Cal-Earth Press, California, USA.
- Langenbach, R. (1989). *Bricks, Mortar, and Earthquakes: Historic Preservation vs. Earthquake Safety*. The Journal of the Association for preservation Technology, Vol. XXI, No. 3&4, pp. 30-43.
- Lee, S. T. & Faisal Hj. A. (2004). *Behavior of Clayey Soils with Cement Additive*. Malaysian Geotechnical Conference, 16-18 March, Sheraton Subang, Petaling Jaya, Malaysia.
- Leslie, J. (1991). *Building with Earth in South Arabia*. Mimar 38: Architecture in Development, London, Concept Media Ltd. pp. 60-67.
- McHenry, P. G. (1973). *Adobe: Build It Yourself*. Tucson, Arizona: The University of Arizona Press.
- McHenry, P. G. (1984). *Adobe and Rammed Earth Buildings: Design and Construction*. New York: John Wiley & Sons.
- McNown, W.C. (1941). *Soil-Cement Building Blocks: An Answer to Inquiries*. School of Engineering and Architecture, University of Kansas, Lawrence.
- Minke, G. (2000). *Earth Construction Handbook: the Building Material Earth in Modern Architecture*. Southampton, Boston: WIT Press.
- Minke, G. 2001. *Construction Manual for Earthquake-Resistant Houses Built of*

Earth. GATE-BASIN, Building Advisory Service and Information Network, at GTZ GmbH, Gesellschaft für Technische Zusammenarbeit, Germany.

Montgomery, D.E. (1998). *How Does Cement Stabilization Work?* Development Technology Unit School of Engineering, University of Warwick, UK

Montgomery, D.E. & Thomas, T.H. 2001. *Minimizing the Cement Requirement of Stabilized soil Block Walling*. Department Technology Unit, School of Engineering at Warrick University, Coventry , UK.

Montgomery, D.E. (2002). *Dynamically Compacted Cement Stabilized Soil Blocks for Low-cost Housing*. University of Warwick, School of Engineering, England.

Morris, J. & Booyesen, Q. (2000) *Earth Construction in Africa*. Conference on Strategies for a Sustainable Built Environment, Pretoria, 23-25 August.

Oliver, A. (ed.), (2000). *Fort Selden Adobe Test Wall Project: Phase 1 Final Report*. California: Getty Conservation Institute.

Rawi, N. M., & Wash, A. A. A. (1995). *Strength and Thermal Properties of Plain and Reinforced Soil-Cement*. Journal of Islamic Academy of Sciences, Vol. 8, No. 3

Rigassi, V. (1995). *Compressed Earth Blocks: Manual of Production*. Vol. 1. CRATerre-EAG. Vilefontaine Cedex, France.

Schueller, W. 1996. *The Design of Building Structures*. Prentice-Hall, Inc. New Jersey.

Sibtain N.S. (1981). *To Build a Village*. Afghanistan Journal, Jg 8, Heft 3, pp. 79-89.
Warren, J. (1999). *Conservation of Earth Structures*. Oxford, UK: Butterworth-Heinemann.

The Getty Conservation Institute, (2001). *Conservation*. The Getty Conservation Institute Newsletter, V. 16, No. 1.

United Nations. (1964). *Soil-Cement: Its Use in the Building*. Sales No. 64. IV. 6. , United Nations Publications. New York, USA.

Sustainability:

Fathy, H. (1886). *Natural Energy and Vernacular Architecture*. The University of Chicago Press, Chicago, USA.

- Hyde, R. (2000). *Climate Responsive Design: A Study of Buildings in Moderate and Hot Humid Climates*. New York: E & FN spon.
- Imhoff, D. (2001). *Building with Vision: Optimizing and Finding Alternatives to Wood*. Healdsburg, California: Watershed Media.
- James & James science publishers Ltd., (1999). *A Green Vitruvius: Principles and practice of sustainable architectural design*. London, UK.
- Panschich, E, & Zimmerman, J. (2001). *Mainstreaming sustainable Architecture: Casa de Paja: A Demonstration*. Corrales, New Mexico: High Desert Press.
- Saini, B.S. (1980). *Building in Hot Dry Climates*. New York: John Wiley & Sons.
- Sharma, A., Dhote, K. K. & Tiwari, R. (2003). *Climatic Responsive Energy Efficient passive Techniques in Buildings*. The Institution of Engineers, India. Technical Journals: Architectural Engineering, Vol. 84, April.
- Wines, J. (2000). *Green Architecture*. Taschen, Italy.
- Wright, D. & Andrejko, D. A. (1982). *Passive Solar Architecture: Logic and Beauty*. New York: Van Nostrand Reinhold Company.

Theory:

- Ardalan, N. & Bakhtiar, L. (1973). *The Sense of Unity: The Sufi Tradition in Persian Architecture*. ABC International Group, Inc. Chicago, USA
- Beng, T. H. (2001). *Modernizing Appropriations/ Appropriating Modernity*. In A. Tzonis, L Lefaivre & B. Stagno (Eds), *Tropical Architecture: Critical Regionalism in the Age of Globalization* (pp.93-103). New York: Wiley-Academy.
- Curtis W.J.R. (1986). *Towards and Authentic Regionalism*. Mimar, 19, Jan.-Mar., pp. 24-31 *Architecture in Development*. Singapore: Concept Media Ltd.
- Fathy, H. (1973). *Architecture for the Poor*. Chicago:University of Chicago Press.
- Nesbitt, K. (ed). (1996). *Theorizing a New Agenda for Architecture: an Anthology of Architectural Theory 1965-1995*. Princeton Architectural Press, New York, USA.
- Pallasmaa, J. (1996). *The Eyes of the Skin: Architecture and the Senses*. London: Academy Group LTD.
- Pallasmaa, J. (1988). *Tradition & Modernity: the Feasibility of Regional*

Architecture in Post-Modern Society. Architectural Review, May, pp. 27-34.

Saliya, Y. (1986). *Notes on the Architectural Identity in the Cultural Context*. Mimar 19: Architecture in Development, London, Concept Median Ltd. pp. 32-33

Taylor, B. B. (1986). *Perspectives and Limits on Regionalism and Architectural Identity*. Mimar 19: Architecture in Development, London, Concept Media Ltd. pp. 1921.

Wilson, St.J.C. (1995). *The Other Tradition of Modern architecture: the Uncompleted Project*. London, England: Academy Group Limited.

APPENDIX

DOCUMENTATION OF THE DESIGN PROCESS

PROPOSAL ONE:

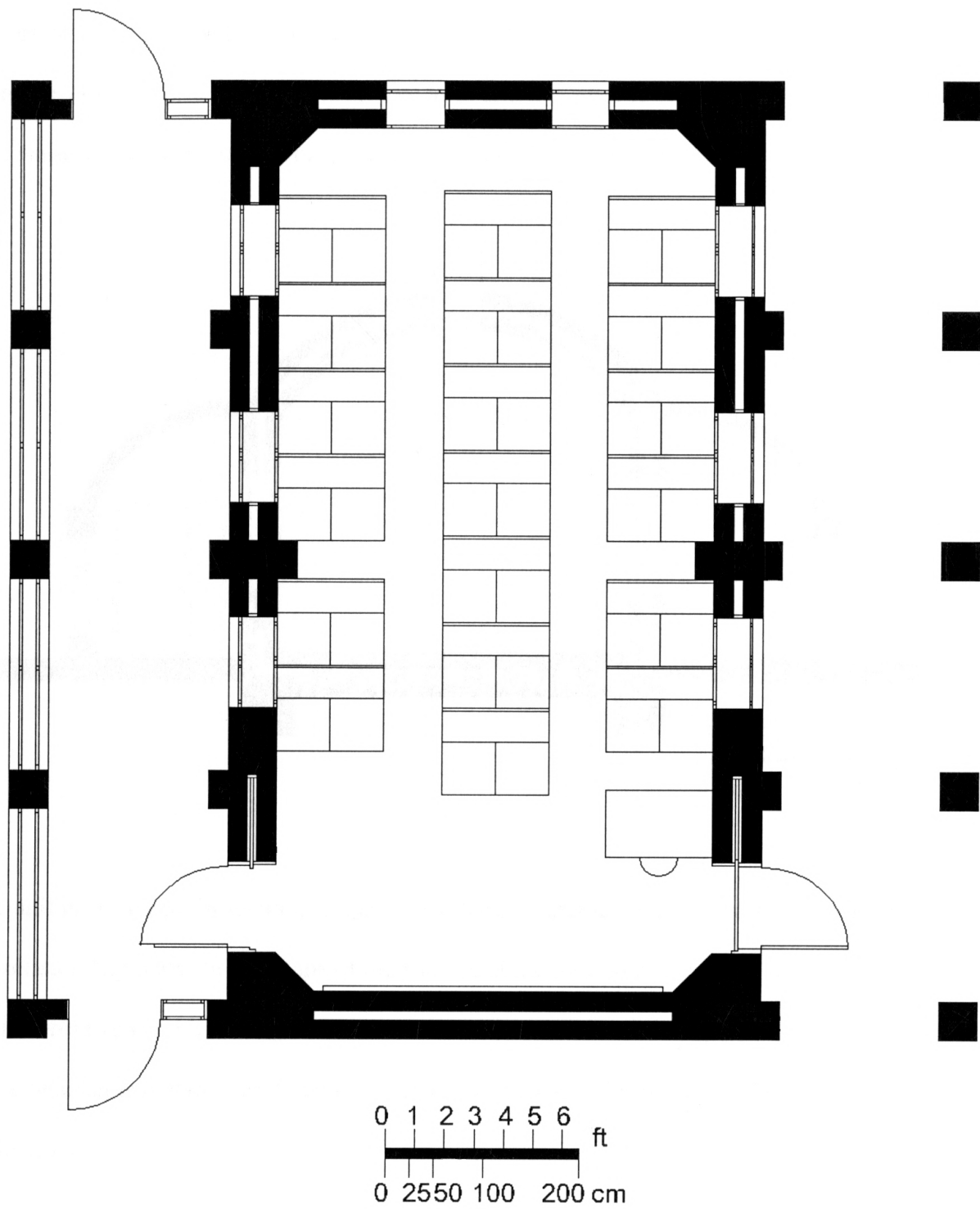

This prototype is divided in three sections: enclosed sunspace or main entry, main classroom unit, and shaded arcade. The clear span of the classroom area is 4.5 meter by 9 meters. It is covered by two domes, which are 4.5 meters by 4.5 meters. The two other areas are covered by a vault type roof. The total unit is a square, 10 meters wide and long. The walls of the main classroom space are 50 cm wide with 10 cm of an air gap.

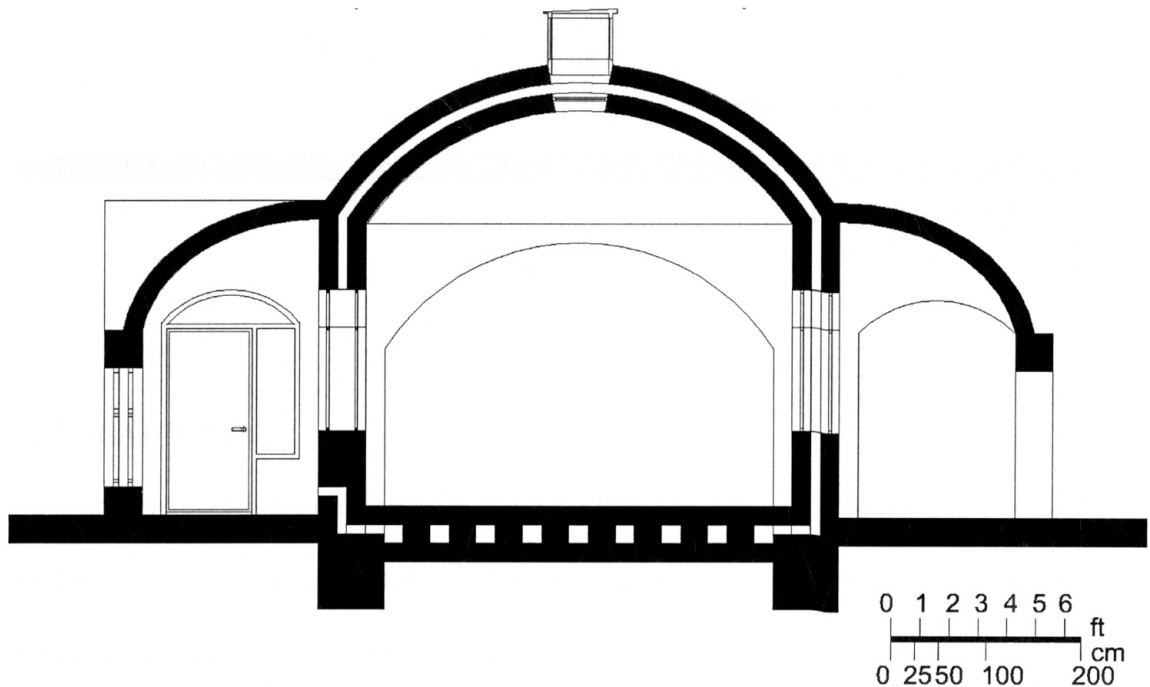

The unit is criticized for its unused spaces and lack of alternative space variations. Due to the relationship between the shape of the space and the roof type, use of the double dome is also criticized and it is suggested that the use of a vault would be appropriate if the space beneath is rectangular. Later on with the other proposal this idea lead to shape the main space.

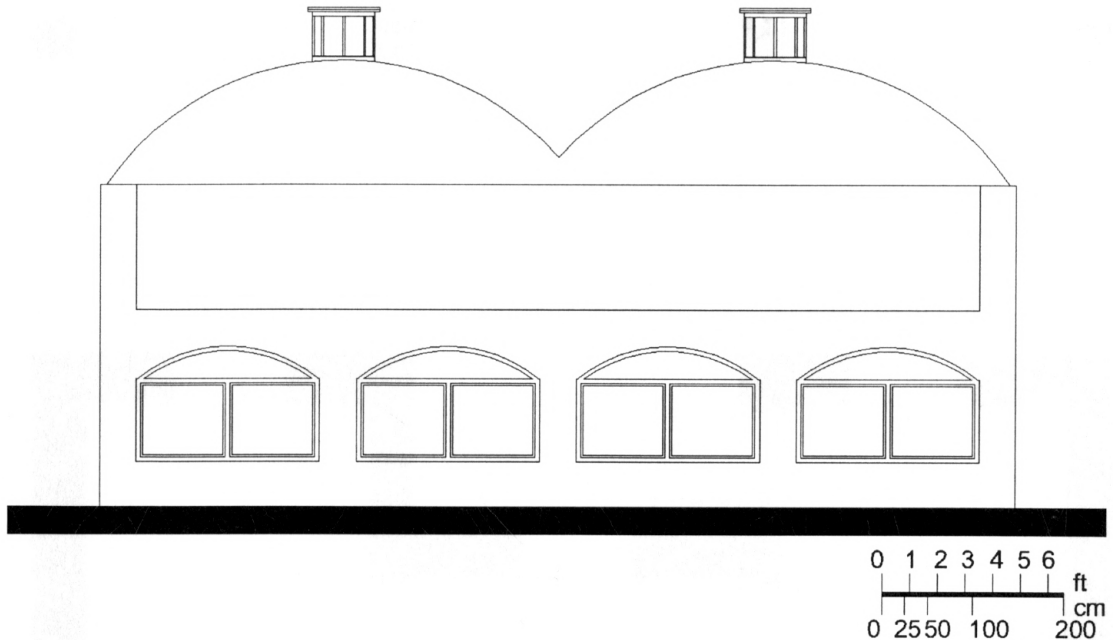

PROPOSAL TWO:

This is an asymmetrical solution with various alternative spaces. Zoning is more explicit than the first one. It has a 5 meters by 5 meters dome on top of the classroom area and a vault on top of the blackboard and teacher's realm. Two small cells are on each corner of the middle zone. One is for storage and heating purposes and the other one is a protected entrance. The front colonnade area is covered on two sides with dome structure and in the middle towards the entrance niche is covered with a vault.

This unit does not work very well due to its asymmetrical design. It required two units to be more completed. The spaces were not big enough to enable other functions. This unit helped to shape the existing classroom area and the existing vaulting roofs. The existing design became a mixture of these two proposals.

