

DEVELOPMENT OF A NATURAL CONVECTION DRYER
FOR ON-FARM USE IN DEVELOPING COUNTRIES

by

FRANCIS NOEL BOLDUC

B. S., University of Vermont, 1973

A MASTER'S THESIS

submitted in partial fulfillment of the

requirements for the degree

MASTER OF SCIENCE

Department of Grain Science and Industry

KANSAS STATE UNIVERSITY
Manhattan, Kansas

1978

Approved by:

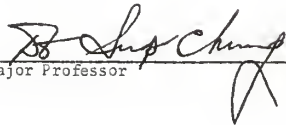
Major Professor

Document
2668
TH
1978
B65
C-2

ACKNOWLEDGMENTS

The author wishes to express his sincere gratitude to the members of his graduate committee, Dr. Carl R. Hoseney and Dr. Paul A. Seib, for their support in the completion of this study. Special thanks go to the author's major advisor, Dr. Do Sup Chung, for his technical aid and assistance in helping to organize and evaluate this thesis work.

The author wishes to recognize the Feed and Food Grain Institute of Kansas State University for the financial assistance they provided for this project. The author would also like to express his sincere appreciation to the following people for their unrelenting support:

- Richard Cook: (Director of Cloud County Ceramics, Concordia, Kansas) for his generous donation of 24 yd³ of Kaolinite clay for the dryers without which the feasibility of this research would have been dim.
- Dr. Robert Julian: for his stern and vigorous support without which the author would not have finished this study.
- Dr. K. E. Kemp: for helping analyze the data statistically.
- Sam G. Maurer: fellow roommate and friend whose unlimited patience and guidance helped the author not only orient himself with KSU but also commence on the right foot.
- Dr. H. B. Pfost: for his technical guidance.
- John E. Robson: fellow roommate and friend whose physical support in helping to construct the dryers played a major role in their successful completion.

Patricia L. Stewart: a deep appreciation for her sacrifices in typing both the tentative and final copy of this thesis.

Rao G. Vemuganti: a friend whose computer abilities proved irreplaceable for helping analyze the drying data.

Last and most important of all I would like to thank my parents (Fernand O. and Jeanne A. Bolduc) for their unyielding moral and financial support throughout my college career.

TABLE OF CONTENTS

	Page
LIST OF TABLES.	v
LIST OF FIGURES	vi
INTRODUCTION.	1
LITERATURE REVIEWED	4
Factors Affecting Drying Methods.	5
Methods of Drying	8
Low Temperature Dryers.	10
Medium Temperature Dryers	13
Brook Type Dryer.	15
Natural Convection and Buoyancy Force	18
High Temperature Dryers	19
Selecting a Grain Dryer	20
OBJECTIVES.	22
MATERIALS AND METHODS	23
RESULTS AND DISCUSSION.	41
CONCLUSIONS	72
REFERENCES.	74
APPENDIX.	76

LIST OF TABLES

Table	Page
1. The Comparison of the Unmodified Dryer and the Modified Model	24
2. Brief Description of All Drying Trials	38
3. Experimental Results on Drying Rate and Fuel Efficiency for All Drying Tests.	42
4. Effects of Grain Depth and Initial Moisture Content on Drying Rate, Dryer and Fuel Efficiency.	46
5. Effects of Turning Time and Air Inlet Size on Drying Rate and Fuel Efficiency.	51
6. Analysis of Variance for Examining Four Main Factors Based on the Drying Rate	63
7. Analysis of Variance for Examining Various Factors Based on the Drying Rate	64
8. Regression Analysis of Drying Tests: Linear Regression.	66
9. Regression Analysis of Drying Tests: Exponential Form	68

LIST OF FIGURES

Figure		Page
1A.	Unmodified Dryer with Screen Floor for Drying Unshelled Maize	25
1B.	Cross-section of Unmodified Dryer Showing Interior of Flue Trench without Drying Floor or Heat Exchanger.	25
2A.	Top View Showing Flue Trench of Unmodified Dryer.	26
2B.	Top View Showing Flue Trench of Modified Dryer.	26
3A.	Side View Showing Height of Drying Floor and Air Inlet beneath Flue in Unmodified Dryer	27
3B.	Side View Showing Height of Drying Floor and Air Inlet beneath Flue in Modified Dryer	27
4A.	Front View Showing Height of Unmodified Dryer and Air Inlet.	29
4B.	Front View Showing Height of Modified Dryer and Air Inlet.	29
5A.	Protective Shelter over Dryers	30
5B.	Log Supports for Drying Floor.	30
6A.	Perforated Sheet-Metal Floor for Shelled Maize	31
6B.	Oil-Drum Flue in Trench beneath Drying Floor Logs	31
7A.	Firebox without Draft Cover.	32
7B.	Firebox with Adjusted Draft Cover.	32
8A.	Dryer Appearance during Typical Drying Trial	35
8B.	Airflow Measurement in a Bed of Maize.	35
9.	Effect of Grain Depth on Drying Rate for Both Modified and Unmodified Dryers.	49

Figure	Page
10. Effect of Turning Time on Drying Rate for Both Unmodified and Modified Dryers.	52
11. Effect of Air Inlet Size on Drying Rate for Both Unmodified and Modified Dryers.	53
12. Temperature Variations of Drying Tests for Modified Dryer	56
13. Temperature Variations of Drying Tests for Unmodified Dryer	57
14. Moisture Distribution in Grain Bed in Modified Dryer	59
15. Moisture Distribution in Grain Bed in Unmodified Dryer	60
16. Linear Regression Plots of Drying Tests for Trial Numbers (B-1) Unmodified Dryer, (L-2) and (P-2) Modified Dryer	71

INTRODUCTION

The problem of grain drying in tropical and subtropical nations of the world has become acute, especially for the crops harvested during a rainy season. These nations are looking for not only more effective grain drying methods to minimize post-harvest losses but also for better methods to preserve grain quality.

In tropical regions the benefits are general in that it is possible to increase production through better drying methods by making possible the practice of multiple cropping whereby an off-season crop is harvested in humid weather.

In subtropical regions one of the most important problems faced is that the moisture content is high at harvest time (such as the end of the long rainy season for maize) and sun drying is usually not possible before storing and marketing because of continuous cloudy weather during the short dry season. For example, harvested maize in Benin often has a moisture content of 22-25% (wet basis) during a time when the relative humidity is usually about 80%. The range in temperature is from 70°F - 93°F with an average yearly rainfall of 60" peaking in two months; 65% of this annual rainfall falls during the long rainy season. The following figure illustrates well the given situation in subtropical Benin (Fig. A).

Under high humidity conditions during harvest, it is necessary that there be an added source of heat energy provided to supply the heat of vaporization. In the temperate regions of the world where the western nations are located, dryers have been thoroughly developed. These dryers,

however, have not been introduced successfully into tropical and subtropical regions of the world not only because of climatic differences but also because of the technological gap existing between temperate and tropical zone nations and the very small land holdings that tend to be typical of tropical zone farmers. The latter tends to put these farmers at a great economical disadvantage in acquiring good drying facilities. Therefore, the main challenge for these nations in this field is the ability to adapt known technology to their specific situations.

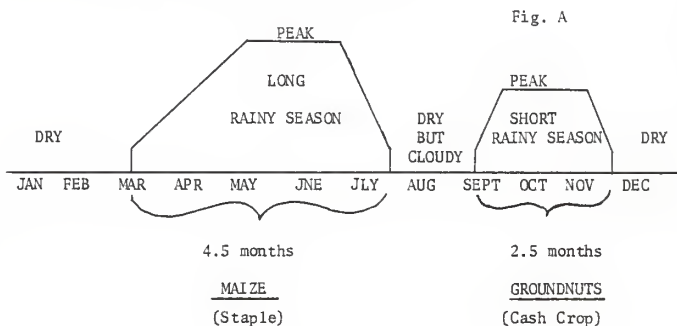

All too often aid comes to these developing nations in the form of technological improvements having high initial costs and requiring well trained personnel for their maintenance and repair. Instead of improving the conditions of the subsistent farmer, the aid makes him more dependent on the aid agency particularly for spare parts. This adverse situation can be avoided by utilizing local know-how and local building materials to their fullest extent; this is also known as appropriate technology.

The goal of this study is to modify a simple and inexpensive natural convection maize dryer (Brook's type) to improve its drying efficiency. An actual field model was built and tested not only with the new design modifications in mind but also with the intent of retaining its low cost properties so that it may continually be used by subsistent farmers in the tropical and subtropical regions of the world. The approach proposed in this study is to evaluate the modifications made to the Brook's type dryer presently being used in the West African Republic of Benin as to how much of an improvement (efficiency and capacity) the new model will create.

LITERATURE REVIEWED

Drying practices have come about mainly because of the great human need for food and feed which in turn places great demands on farmers and industries. Because of this it is essential, now more than ever, that food grains be dried quickly and effectively while maintaining a high quality product. Drying is not only necessary for grain preservation by reducing its moisture content to safe levels, but it also represents many advantages for the farmer in the following respects:

- (1) long term storage is possible without deterioration,
- (2) grain can be harvested early at high moisture contents thereby minimizing field infestation,
- (3) seed viability can be maintained for longer periods of time,
- (4) the growth of bacteria and fungi along with the development of mites and insects is prevented or seriously controlled and most important of all to the farmer is that
- (5) a better product usually resulting in better economic gains is attained.

It is the more prosperous nations in the temperate zones of the world that have utilized advanced technological drying practices for years and are still acquiring new technological advances in this field while the developing nations located mainly in tropical and subtropical regions of the world remain far behind on the subject of grain drying. Not only do they in general lack good grain handling methods but they also have the worst climatic conditions for drying: high temperatures and excessive humidity, which are two of the most important variables of control in the grain drying process.

Wheatly (1972) reported record weight losses due to insects, rodents and molds in traditional storage units for maize in three African nations located in the continent's tropical and subtropical zones. They are as follows:

- (1) Kenya - an average weight loss of 23% over a 6 month storage period.
- (2) Uganda - an average weight loss of 16% over a 7 month storage period.
- (3) Ghana - an average weight loss of 35% over a 6 month storage period.

For Africa as a whole, Wheatly reported that maize losses due to insects, rodents and molds have been assessed at 10% by weight per year which brings total losses to Africa to 2 million metric tons per year.

The importance for nations with climatic characteristics so different from those of the temperate zone that have well developed drying methods is to choose drying methods which are applicable for local situations and purposes. Limitations such as available energy sources, labor availability, market size, technological levels, etc. should be well considered before attempting to apply drying methods developed elsewhere.

FACTORS AFFECTING DRYING METHODS

I. RELATIVE HUMIDITY AND MOISTURE CONTENT

Relative humidity is the ratio of the amount of water in the air to the maximum amount that a given sample can hold at a given temperature. It is always expressed as a percentage and will indicate how much more moisture may be absorbed by the air. Therefore air with a relative humidity of 75% has a much less drying capability than air at a relative humidity of

60%. The main factor affecting relative humidity is temperature.

When crops at a given moisture content are exposed to air at a constant relative humidity there will be a moisture transfer from the grain to the air or vice versa. Given enough time these crops will eventually attain a given moisture content that is dependent on what the relative humidity is. This final moisture content that is attained is called the equilibrium moisture content. The minimum moisture content that grains are usually dried to is between 10 and 14% (wet basis).

II. TEMPERATURE

As previously mentioned, temperature is the main factor affecting relative humidity but it also plays an important role in the heat transfer process.

The temperature reached by the grain itself is much more important than the temperature of the drying air because overheating of the grain itself during drying can:

- (1) kill the germ,
- (2) change the nature of the chemical constituents such as denaturing the protein, decreasing the fat acidity, or delatinizing the starch,
- (3) crack the endosperm,
- (4) blister the grain, and in an extreme case,
- (5) char the grain.

Therefore safe temperatures for drying depend on the temperature of the grain itself. Brooker et al. (1974) stated that if short passes are made through a dryer, the air can be much hotter than the "safe" temperature, especially if the grain is not much above a moisture content of 14% (wet

basis) when entering the dryer, but at a moisture content of 20% (w.b.) and higher, if the temperature is much above that indicated as "safe" for preserving quality then the grain can be easily cooked and thus ruined.

III. AIRFLOW OR AIR MOVEMENT

In general, for the purposes of drying, air carries heat through grain to evaporate moisture and then carries the evaporated moisture out of the grain. In aeration drying air carries off heat from the grain mass thereby initiating a cooling of the grain itself.

To move air through grain, pressure is required to overcome the resistance to flow by the grain itself and the amount of pressure depends on what kind of grain you are drying, the rate of airflow and the path length that the air must follow to flow completely through the grain.

IV. GRAIN CHARACTERISTICS

The nature, size and shape of a grain have a general effect on when it will come to moisture equilibrium. Also, theoretical characteristics such as a grain's specific heat, its heat of vaporization of internal moisture and its vapor pressure of moisture have a very important role in equations developed for determining equilibrium moisture content.

V. DEPTH OF GRAIN IN BULK

It is difficult to mention grain characteristics in relation to drying without mentioning them in "bulk" since this is the most common way of drying grains artificially. It is a complex process since each grain kernel at any instant dries as though it were individually exposed to the conditions surrounding all the other kernels and these conditions are constantly changing during bulk drying. They are also dependent on all the factors that affect drying methods such as airflow rate through the

grain mass, initial temperature of the drying air, initial relative humidity of the drying air, initial moisture content of the grain and the depth of the "bulk" of grain.

METHODS OF DRYING

There are essentially two main methods of drying, natural and artificial. Both will be discussed along with their many corresponding subdivisions especially when pertaining to the technological level of this research.

I. NATURAL DRYING

This method consists simply of using the sun's rays and present atmospheric conditions for drying grain.

1) Sun Drying. While crops are maturing in the field, there tends to be a natural decrease of their moisture content. Pedersen (1976) mentions that grains are generally considered matured or "ripened" when there is no more increase in dry matter by the grain kernel. Drying will continue after maturity is reached given favorable conditions such as plenty of sunshine, warm temperatures, and low relative humidity.

In tropical countries many crops are left in the field to mature and dry but a much more widespread practice is to harvest before field infestation by insects becomes serious and spread the grain out on flat surfaces turning it occasionally so that the sun's rays may reduce the moisture content as much as possible.

Concrete slabs are widely used next to warehouses and large scale farms in tropical regions where there is plenty of cheap labor available for turning the grain constantly but by far the most common method used by the large majority of small farmers is to spread the grain on beaten earth

(which leaves a lot to be desired concerning sanitation). The disadvantages with this system are:

- a) seed viability is easily destroyed when temperatures exceed 110°F for any length of time (maize),
- b) moisture from the soil can condense on the grain,
- c) dirt can easily mix with the grain (disease potential),
- d) insects have easy access to the grain and
- *e) the grain must be moved with every threat of rain!

2) Natural Ventilation. In West Africa it is a very common sight to see many different designs of indigenous crib dryers on village farms made of bamboo frames, thatched palm-branch sides and a thatched straw roof. Other designs use wood for the frames and tin sheeting for the roofs. Whatever the design the purpose is all the same, to dry the grain using natural ventilation.

Other methods consist of tying crops in bundles in the rafters over kitchen areas so that smoke from the cooking fires will keep insects out of their crop. Whatever the means may be, it is quite obvious that the majority of methods used in tropical and subtropical regions suspend the crops, in one manner or another, above ground not only for better ventilation but also for protection against rodents and farm animals.

II. ARTIFICIAL DRYING

This method may also be called the heated air drying method because it uses heat to make unfavorable conditions of the air more favorable for drying or it makes favorable conditions even more favorable not only to increase the drying rate but also the drying capacity. Three major groups will be discussed: low temperature systems, medium temperature systems and high temperature systems.

A. LOW TEMPERATURE DRYERS

The simplest method of artificial drying consists of increasing the airflow rate through the grain by means of a fan. Air at ambient conditions can be used for this purpose as long as anyone using this method keeps in mind that the relative humidity of the air should be below the equilibrium moisture content of the grain. The problem arising with this method is that it must be very carefully watched because the relative humidity of the air never remains constant. It is normally much higher at night than it is during the day. This is a good and economically sound method of drying as long as those using it are well aware of the limitations with drying using ambient air conditions. For example, in the West African tropical and subtropical regions, it is very common to have average temperatures of 90°F with average relative humidities of 80% during the harvest time for maize (which is at the end of the long rainy season). Brooker et al. (1974) gives us an equilibrium moisture content for maize under these conditions at 16.2% (wet basis). Since maize is harvested at a moisture content of between 22 and 25% (wet basis) this means that between 5 and 8% of the moisture can be driven out with natural aeration drying. The rest of the moisture would have to be driven out with heated-air drying given that the relative humidity and temperature condition would remain constant.

Low temperature drying is very appropriate for the above example. It raises the drying air temperature only enough to assure that the air humidity is adequate to reduce the moisture content of the grain to safe levels. A good rule of thumb to follow is that if you raise the air temperature by 10°F then you create fairly good drying conditions. Take the formerly mentioned tropical condition where you have a wet bulb

temperature of 85°F and a dry bulb temperature of 90°F giving a relative humidity of 80% at which the equilibrium moisture content of maize is 16.2% (w.b.). Just by raising the dry bulb temperature to 100°F you lower the relative humidity from 80% to 55%. Brooker et al. (1974) gives the equilibrium moisture content of maize at 100°F with a relative humidity of 55% as 11.3% (w.b.). Although this final equilibrium moisture content was interpolate thereby making it relative, it at least demonstrates the drying potential of a low temperature use of the drying air under normal tropical conditions during harvest time in West Africa.

Muckle and Sterling (1971) have shown that by raising the air temperature 1°C, (1.8°F), you can reduce the relative humidity of the air approximately 4.5%. Holmes and Lipper (1974) classified low temperature dryers as those that employ only enough heat to increase the air temperature 20 to 40°F and considered it impractical at these temperature rises to use electric heaters. Instead they recommended that waste heat from engine-driven fans be used to obtain these low temperature rises.

1) On-the-Floor-Dryers.

With this system grain below 21% M.C. (wet basis) is laid on a floor with a depth of no more than 2 meters (6.56 feet). Lateral ducts connected to a power source supply the air forced through the grain mass at a minimum airflow rate of 5 m/min (16 ft/min). The airflow rate can be checked with a simple airflow meter.

Since drying takes place from the bottom layer up, the relative humidity of the air should be monitored as the moisture content of the grain changes. Excessive temperatures will cause overdrying in the bottom layers and condensation of moisture in the upper layers.

The main problem with on-the-floor dryers is with insect infestations. Since this dryer is only suitable for bulk handling it makes it difficult to load and unload without mechanical equipment.

2) In-Bin Dryers

These dryers represent one of the most common systems in use today in which crops are dried in circular or square bins with a wide range of capacities usually between 10 and 100 tons. Their usefulness stems mainly from the fact that grain is dried and stored within the unit itself thereby minimizing grain handling and exposure. Ambient air conditions determine the size of the heater to be chosen and of course the grain capacity and the type of grain to be dried will determine the fan size. Although electric heaters many times prove to be not very practical, they are usually present to raise the air temperature.

The drying takes place in layers with the bottom layer being dried first. The fan should not be turned off until the drying layer is either completely pushed or pulled through the entire grain mass. The relative humidity should be kept below 70% to avoid the danger of grain rewetting. Brooker et al. (1974) reports that in many areas of the United States humidistats for maize are set at 55% during drying so that resulting plenum air conditions are such that the maize is dried to 12-13% moisture content (wet basis).

Muckle and Stirling (1971) recommend that grains at a moisture content of 22% or less (w.b.) should not be dried in depths greater than 10 feet and that grains with moisture contents greater than 22% should not be dried in depths greater than 5 feet. Brooker et al. (1974) does not quite agree with this saying that small grains harvested during the warmer

months at moderate moisture contents (20% (w.b.) or less) can be dried in depths of up to 16 feet and that maize harvested late enough in the fall when temperatures are relatively low can be dried at this depth with moisture contents of up to 25% (w.b.). The slow drying rate and the mold growth-temperature-time relationship dictates the initial moisture content.

Brooker et al. (1974) recommends that for a depth of 16 feet of maize, the airflow rate should vary with the initial moisture content of the grain. It is recommended that maize with an initial moisture content of 25% (w.b.) have an airflow rate of 5 cfm per bushel while the same grain at an initial moisture content of 16% (w.b.) need only have an airflow rate of 1 cfm per bushel.

The advantages attributed to full in-bin drying are:

- 1) The grain can be harvested at any rate desired.
- 2) The management is relatively simple.
- 3) Grain handling is at a minimum.
- 4) Heat in the drying air is efficiently used.
- 5) Grain is not over dried.
- 6) The low temperature air causes a minimum number of stress cracks.

Its disadvantages are:

- 1) Harvesting cannot take place at high moisture contents.
- 2) The drying process is long, requiring a long management period.

B. MEDIUM TEMPERATURE DRYERS

The greatest use for this system arises when higher moisture extraction rates are required, when heat from the fan engines is not enough to dry

the grain. In this case oil fireboxes or electric heaters are used to accomplish the desired temperature rise.

1) Batch-In-Bin and Dryeration

The Batch-In-Bin system is used for larger operations than the In-Bin dryers. Here the grain is dried in single batches in bins and then transferred to storage bins.

The operating principle of this type of dryer is to force large quantities of heated air through relatively shallow thicknesses of grain to obtain rapid drying. Air temperatures going into the bin are about 120°-160°F with airflow rates ranging from 8 to 15 cfm per bushel. With maize the layer is usually never more than 4 feet deep and when the average moisture of the grain reaches the desired final moisture content then the grain is cooled simply by turning the heater off and letting the fan run. Grain is then moved either for storage or for marketing.

In a modified system, called dryeration, the grain is partially dried in a bin to a moisture content of 16 to 17% (w.b.) using heated air as hot as 240°F (but with the actual kernel temperature remaining between 120 and 140°F). The grain is then transferred to another bin where it is allowed to temper to allow the moisture within the kernel to redistribute to eliminate the moisture gradient between the kernel interior and the kernel surface. The moisture redistribution process takes anywhere from 4 to 10 hours. The final 2% of moisture is finally removed in 6 to 12 hours by using an airflow rate of 0.5 to 1 cfm per bushel. Brooker et al. (1974) sums dryeration into 3 major stages:

- 1) high temperature drying (up to 240°F).
- 2) tempering (4 to 10 hrs.).

3) cooling accompanied by final drying (6 to 12 hrs.)

These systems are applicable where larger quantities of grain are handled and require more capital investment and more handling equipment than previously mentioned low or medium temperature dryers. Good supervision is also required to avoid grain spoilage.

Dryeration systems use fuel more efficiently and produce less stress cracking with increased capacities.

2) Brook Type Dryer

This system of drying could very well be called the "Model T" dryer of the modern Batch-In-Bin Dryeration dryers of the Western world. It is definitely a batch type dryer using moderate temperatures to dry a thin layer of grain down to a desired moisture content. The grain is then removed to cool before storing or marketing.

Despite its apparent primitiveness, the Brook type dryer has actually undergone quite a development starting with the original Samoan Cocoa Dryer.

Bournville (1958) was the first person to publish an article on the Samoan Cocoa Dryer which is a very primitive natural convection dryer used to dry white coconut meat (copra). The copra is placed on a drying floor under which a fire is built for drying. Direct firing is used; that is, smoke, flying embers, sparks, etc. pass through the drying floor.

J. A. Brook (1961) took the Bournville (1958) specifications for the Samoan Cocoa Dryer and modified it for use as a groundnut dryer in northern Nigeria. From 1961 to 1963 at the Mokwa Sub-Station at Ahmadu Bello University, Brook modified, built and tested his modifications until he came up with a good workable model for drying groundnuts at the farm and village level.

Later Webb (1969) took Brook's model and redesigned, constructed and tested it for maize drying in the Western State of Nigeria. He raised the drying floor to 2.5 feet above the firebox to prevent the crop in the center from becoming scorched during the drying process. It was recommended that a 4 inch layer of shelled maize with a mean drying temperature of 130°F in the plenum chamber be used.

The Webb model was made of adobe blocks with a simple thatched cover and with most of the work involved with the construction undertaken by the farmer himself, but still a considerable amount of supervision by someone familiar with the dryer was needed.

Operation of this dryer was simple and required that a "wood fire be kept alight continually for about 3 days and nights and that the heat generated would not become excessive at any time." This dryer could dry 1 metric ton of maize in 3 days.

Wheatly (1972) reported that considerable encouragement was given to farmers in the Western State of Nigeria to build this type of dryer but the response was extremely disappointing. Wheatly believes that the most probable factor to its failure was that the local societies in Nigeria did not have staff with adequate organizational ability or sufficient technical experience or knowledge to ensure operation of the dryer with a reasonable degree of efficiency.

When Webb (1969) was demonstrating his model dryer in western Nigeria, a group of Peace Corps-Benin agriculture volunteers from Cotonou attended. Returning to Benin they worked with the model in 1969 and 1970 at the IRAT (Institut de Recherches Agronomique Tropicales et des Cultures Vivrieres) research station near Niaouli, Benin. In 1971 they introduced the Peace

Corps-Benin model of the Brook type dryer, which they had also remodified to the point where the only non-indigenous materials of the entire dryer were the 3-55 gallon capacity oil barrels, to the Beninian farmer. Other non-indigenous materials such as chicken wire or corrugated tin-sheeting were sometimes used as a drying floor because these materials happen to be locally available where the dryers were being built.

The author of this thesis worked for two years (1974-1975) with this model dryer in the subtropical region of Benin as a Peace Corps grain storage volunteer. By the end of the year (1975) southern Benin had 144 of these Brook type dryers built to help with maize drying. We were much more successful with its introduction to Beninian farmers than Webb was with the Nigerian farmers.

As previously mentioned, this model dryer is basically a batch dryer having a rectangular pit forming both a chamber for the oil barrel flue and for the stoking area. The laterite soil from the excavation of the pit is used to build the adobe walls which bind the flue-pit and support the drying floor. The enclosed space below the floor forms the plenum chamber in which the gas-tight flue made of oil drums is placed. The stoking pit is actually located outside the dryer itself in front of the firing-barrel but is a continuation of the initial dug-out flue-pit. Air heated by the fire in the first barrel (firebox) rises through the grain on the drying floor. The drying floor is 1 meter (3.28 feet) from the surface of the oil-barrel flue to the surface of the drying floor. The drying floor surface has an area of 2.20 m (7.22 ft) by 2.40 m (7.87 ft). It takes 48 hours to dry 500 kg (1100 lbs) of shelled maize from a moisture content of 25% (w.b.) to 12% (w.b.) with a mean plenum temperature of 60°C (140°F).

(Further discussion of this dryer-type will follow.)

Three Peace Corps-Benin volunteers were responsible for the first construction manual of this Brook type model: Lindblad, Newman, and Vinita (1974).

All these different models based on the James A. Brook type dryer are also based on the same drying principle, natural convection and buoyancy force. It is known that natural or free-convection heat transfer is a result of the motion of fluids due to density changes arising from the heating process.

Archimedes, who is credited with the discovery of this principle, said that, "A body is buoyed up by a force equal to the weight of the fluid displaced." In other words, if an object is less dense than the fluid it is placed in, it will float.

Thus the expansion of the air in the plenum chamber of these dryers caused by heat radiating from the fire-barrels causes the heated air in a cubic foot of space to become less dense than the outside ambient air (per cubic foot of space). Because the upward buoyancy force (F_B) of the denser ambient air is greater than the downward weight of heated plenum air (W), the heat-expanded air is pushed upward through the drying floor with grain. There is a net upward force because F_B is greater than W pushing the heated air upward at certain rate until $F_B = W$. Of course grain resistance and resistance against the drying floor will also play a role on the air-flow rate caused by this principle.

On December 13, 1974, there was an international conference on the grain storage problems of African village farmers held in Cotonou, Benin. One of the attendants was Dr. Do Sup Chung, Agriculture Engineer from

Kansas State University. Dr. Chung returned to KSU and with one of his graduate students (Kwan Hee Ryu) did the first systematic study on the design criteria and performance of the Peace Corps-Benin-Brook type dryer. This study was published in the form of a Master's thesis by Ryu in 1976. It was based on this study that this author constructed and tested the first field model with the following proposed physical modifications undertaken:

- (1) Increase the height of the standard model dryer (unmodified) by 50%.
- (2) Increase the air inlet of the standard model dryer by 100%.
- (3) Improve the flue trench of the standard model by wedging the flue trench from the air inlet back to the chimney end so that there is maximum air circulation about the fire-barrel and minimum air circulation about the chimney-barrel.

(For details see Appendix.)

C. HIGH TEMPERATURE DRYERS

Where there are large quantities of crops received in a harvest season, the need to dry faster is accomplished by exposing the grain to high temperatures for a short period of time (12-60 min.). The grain loses moisture but will not come to equilibrium with the drying air since the relative humidity has been reduced so much. As the grain leaves the dryer it is cooled down to ambient air temperatures in order to avoid condensation and deterioration. Most commercial dryers employing this principle have their own built in cooling chambers.

Many of these dryers operate on a continuous grain flow principle with the grain being passed over a series of baffles, while falling by

gravity, through which air is being blown as the grain moves.

Not all continuous flow dryers are vertical. Some are horizontal and contain grain laid flat on a moving bed through which air is blown.

Continuous flow dryers have capacities of from 1 ton to 40 tons per hour. They require skilled operators due to the danger of overdrying and operate with temperatures as high as 230°F.

Materials that are not free flowing and that are not damaged by continuous handling are sometimes dried in rotary dryers. These dryers utilize single, double or triple drums which can be fitted with flights that lift the material and shower it down through heated air. Multiple drum types are preferred because the overall length can be regulated and heat loss due to conduction and radiation is small.

The main disadvantages of the rotary dryers are that they have a high initial temperature and occupy more floor area per unit capacity than batch or column type dryers. Their use should be avoided if batch or column type dryers are suitable.

III. SELECTING A GRAIN DRYER

Finally we come down to the principal considerations that one should review before choosing a grain dryer. So different are the range of conditions varying from temperate to tropical zones of the world that the applicability of a particular system is the first thing one should look into before selecting a drying method. General considerations that should be thoroughly studied are characteristics such as drying capacity, cost of installation, control of drying, ambient air conditions of the area, air temperature used by dryer, safety of operation, uniformity of output, suitability of handling equipment and ease of cleaning.

It is possible to employ, in one way or another, all the dryers mentioned in this review (provided they meet the above mentioned conditions) in tropical and subtropical regions of the world. Definitely the ones most likely to meet success are the low temperature dryers since they can be more easily adapted to local conditions. The low temperature batch type dryers studied in this thesis are definitely good examples of low temperature dryers adapted to local conditions.

Solar drying is by far the most widely practiced drying method for drying cereal grains throughout the tropical and subtropical world. Despite the disadvantages mentioned in the sun drying section of this review, no other drying system may match it economically. As mentioned before, the major use for the Brook type dryers studied in this thesis is to complement the sun drying system and not replace it, especially in subtropical regions where there are two rainy seasons and two dry seasons. All too often the short dry season between the two rainy seasons does not render enough solar energy to sufficiently dry their crops before the next rainy season begins. Here is where artificial drying would be of greatest benefit. In tropical regions the problem is obvious; there is never a significant drying period for cereal crops.

OBJECTIVES

Objective: To develop a more efficient natural convection dryer which can be adopted for on-farm use in developing countries.

Specific Objective: To evaluate the drying performance of a modified dryer with its unmodified prototype by testing four main factors on the drying rate, the fuel efficiency and the grain quality (moisture gradient). The four main factors are:

- 1) Initial moisture contents of 20% and 25% (w.b.).
- 2) Grain depths of 4" and 6".
- 3) Effect of turning the grain every 2 and 4 hours, and no turning as a control.
- 4) Air intakes of 1/2 and full.

MATERIALS AND METHODS

This study consists mainly of a bilateral experiment comparing a modified dryer with an unmodified type of the same gender. This bilateral experiment also carries with it four main factors that were tested (see Objectives). It was intended to evaluate the conventional Peace Corps-Benin-Brooks type dryer in relation to a new modified version developed at Kansas State University in order to find the effects of the four main factors mentioned on the drying performance of maize.

For evaluation purposes both model dryers were constructed with their basic design shown in Figures 1A through 4B. The material to be dried is contained on a removable perforated metal sheet (as shown in Figure 6A) and mounted over a plenum chamber (shown in Figure 6B). The walls enclosing the plenum chamber are constructed of adobe and have a cross-sectional area of 100 ft². The grain rests on the perforated steel sheet secured on 10 - 4"x4"x8' cedar beams (see Figures 5B and 6A) and is attached to the walls with adobe. This way the beams, in time, can be easily removed for making repairs if needed. Twenty-four cubic yards of Kaolinite clay were used to construct the dryers tested; 13 cubic yards for the modified model and 11 cubic yards for the unmodified model. An overall view of these dryers under the protective shelter is shown in Figure 5A.

There are no differences in the construction of both model dryers from the ground level up. The major differences are with the air inlet, the drying floor height above the flue and the flue trench. The differences and similarities are listed in Table 1 while the physical differences and

TABLE 1. The Comparison of the Unmodified Dryer and the Modified Model.

Classification	Unmodified	Modified
Size of Drying Bed	8' x 8'	8' x 8'
Height of Drying Floor from Center of Flue	4'3"	6'5"
Diameter of Flue	2'	2'
Clearance between the Flue-Pit Wall and the Flue Cylinder at the Center Edge of the Flue: (Front)	2"	1'
(Rear)	2"	6"
Size of Air Inlet	3.65 ft ²	8.65 ft ²
Materials of walls	1' thick adobe	1' thick adobe

similarities can be seen in Figures 2A through 4B.

Figures 2A and 2B show the flue trench design for the unmodified and modified dryers respectively. As can be seen, the flue trench for the modified dryer is designed so that there is maximum air circulation about the fire-barrel at the stoking-pit. The reason why the flue trench is not wedged all the way back to the chimney is because of the difficult construction problems that this design caused. Therefore, the trench was left straight from the end of the fire-barrel back to facilitate construction methods.

Figures 3A and 3B show the dryer floor heights for the unmodified and modified dryers respectively. As can be seen, there is a 62.8% increase in floor height of the modified dryer over the unmodified model from the top of the flue-barrels to the top of the drying floors. Also

Peace Corps-Benin Brook-Type Dryer Used in Experiment

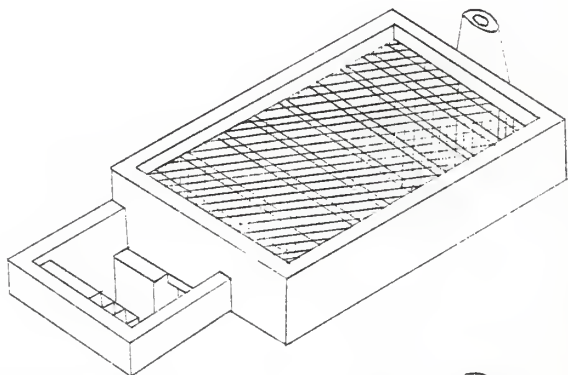

Figure 1A. With Screen Floor for Drying Unshelled Maize.

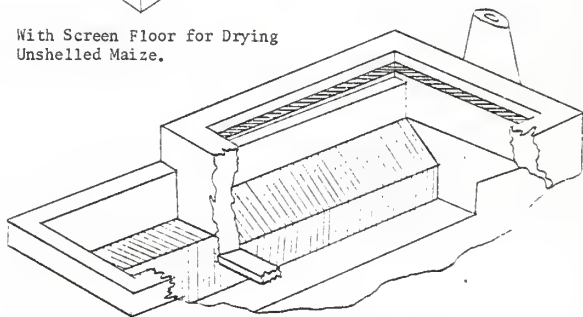

Figure 1B. Cross-section Showing Interior of Flue Trench without Drying Floor or Heat Exchanger

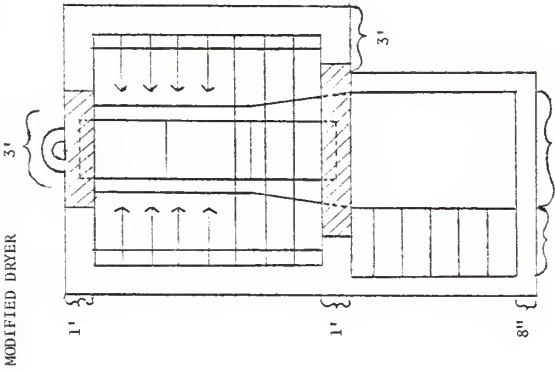

Figure 2B

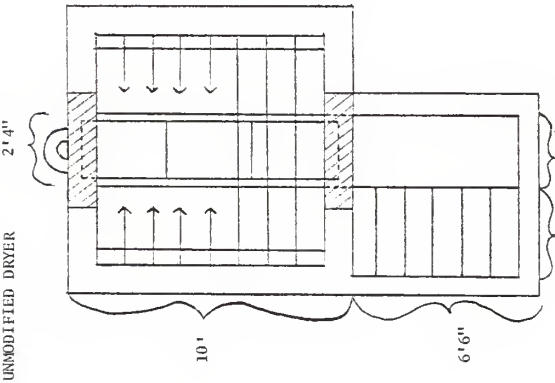

Figure 2A

Top View Showing Flue Trench Difference

UNMODIFIED DRYER

MODIFIED DRYER

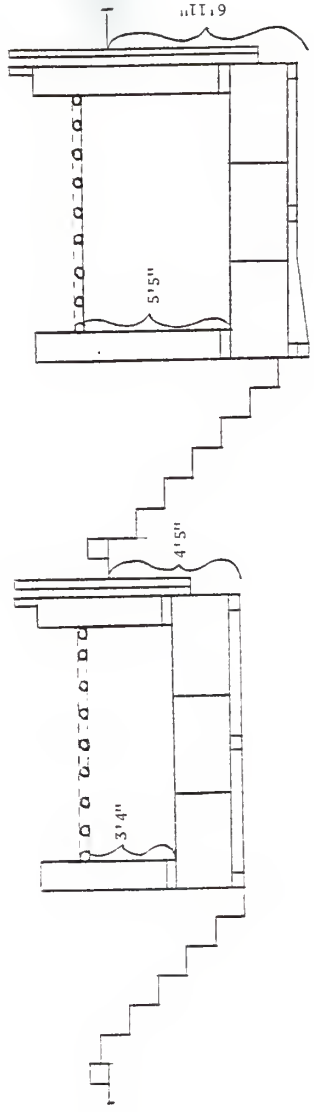

Figure 3A

Figure 3B

Side View Showing Difference in Both Height of Drying Floor and Air Inlet Beneath Flue

notice the 56.6% increase in the depth of the modified dryer over the unmodified dryer from the ground level down to the bottom of the flue trench at the chimney-end. A side view of the air inlet wedge can be seen below the fire-barrel of the modified dryer as opposed to the straight air inlet of the unmodified dryer.

Figures 4A and 4B show a front view of the air inlets and the dryer heights of the unmodified and modified dryers. Figure 4B shows an increase in air inlet size (in ft^2 and shown by the letter I) of more than 100% of the modified dryer over the unmodified model (shown in Figure 4A). There is a total increase in the height of the modified dryer over the unmodified model of 36% from the bottom of the fire-barrel trench to the top of the dryer but this difference is not noticeable with an actual field model since they occur 100% below ground level (also seen in these same figures).

The heating unit [Figures 4A, 4B, 7A (open) and 7B (closed)] consists of 3 - 55 gallon oil drums with all the ends cut out in the manner explained in the construction manual (see Appendix). These drums are placed inside the enclosed plenum chamber as seen in Figures 2A, 2B and 6B. Air is supplied into the plenum chamber through air inlets as seen by the letter I in Figures 4A and 4B. The adobe walls are 1" thick where they enclose the plenum chamber and drying floor. Where they enclose the stoking-pit hole on the sides, they are only 8" thick since their function here is limited to protect the pit against water flow and debris. To make sure the plenum chamber is air tight, fresh adobe was used to fill all major cracks caused by shrinking during the curing process.

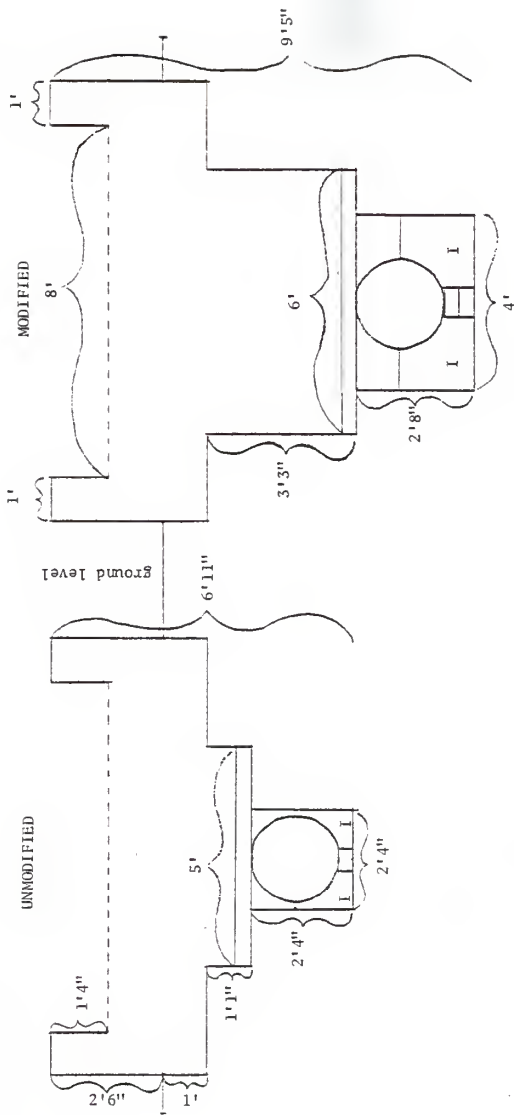

4'5"

Below Ground Level

6'11"

Below Ground Level

Figure 4A

Figure 4B

Front View Showing Height and Air Inlet Difference



Figure 5A. Protective Shelter over Dryers



Figure 5B. Log Supports for Drying Floor



Figure 6A. Perforated Sheet-Metal Floor for Shelled Grain.



Figure 6B. Oil-Drum Flue in Trench Beneath Drying Floor Logs.



Figure 7B. Firebox with Adjusted Draft Cover.



Figure 7A. Firebox without Draft Cover.

The inlet drying temperature was monitored using a Yellow Springs Instrument Company's tele-thermometer (thermistor) and controlled by:

- 1) varying the amount of wood fed to the fire and,
- 2) controlling both the firebox and the chimney draft openings.

Temperatures were measured by thermocouples placed just below the drying floor inside the plenum chamber in both the front and back of the dryers. These temperature readings were recorded every two or four hours depending on what the turning rate for that particular grain trial happened to be.

In preparation of the samples for the drying trials field maize freshly harvested at 25% and 20% was used during the months of September and October, 1977. It was found that over an area of 64 ft² a depth of 4" usually weighed about 1200 lbs and a depth of 6" usually weighed about 1600 lbs (before drying).

The data that was recorded for each trial included the plenum temperature at the front and back of each dryer just below the drying floor, the bottom and top portions of the drying grain in five different locations, the ambient air conditions above the grain, the weight of the wood used for each trial, the moisture content of the grain before each turning and occasionally the air flow rate through the grain.

In the air-inlet tests, the comparison of the airflow rate of the unmodified dryer with that of the modified dryer was studied to see if the new modified air-inlet on the modified dryer made a significant difference on the airflow rate using the same quantity of grain with the same initial moisture content in both dryers. Also the new height of the drying floor in the modified dryer was studied to see if there would be a difference in the airflow rate between the two dryers (Table 1).

No forced convection was used in the airflow tests; only natural convection was tested.

Airflow rate was calculated from the energy consumption using the relationship given by:

$$Q = C_a \times \frac{Z \times 60}{V} \times (T_2 - T_1)$$

where Q: energy consumption (BTU/hr)
 C_a: specific heat of air (BTU/lb °F)
 Z: airflow rate (cfm)
 V: specific volume of air (ft³/lb)
 (T₂ - T₁): temperature rise (°F)

To measure the airflow rate through the grain a hot-wire anemometer (Model B-22: Hastings-Haydist, Inc.) was used with a metal cone to increase the airflow rate to a measurable velocity (see Figure 8B). In calculating the airflow rate the specific heat of air was assumed to be 0.2407 BTU/lb °F throughout the tests (Brooker et al., 1974).

The grain used for all the tests was shelled yellow dent corn, which had been newly harvested in September and October, 1977, at about 25% and 20% moisture content (w.b.). No storage was needed since the trials were being conducted during the harvesting period; therefore the grain was brought from the fields as needed.

The mean initial moisture content of the bed was obtained from samples taken as the dryers were being filled.

In the comparative test the modified dryer has a height 62.8% higher than that of the unmodified dryer (Figures 3A, 3B, 4A and 4B). The inlet sizes and other modifications seen in Table 1 were made according



Figure 8A. Dryer Appearance During Typical Drying Trial.



Figure 8B. Airflow Measurement in a Bed of Maize.

to the recommendations proposed by Ryu (1976).

The wet-bulb temperature of the ambient air was measured by means of a Bacharach sling-psychrometer which also gave the relative humidity. These measurements were also taken every 2 or 4 hrs depending on the turning rate of the grain for any particular trial.

During the test, samples were obtained at different intervals from four subsections in the bed. A Motomco moisture tester was used to determine the time when the desired moisture content had been reached. In each of the four subsections a sample was taken from both the top and bottom of the bed for the determination of the moisture gradient within the bed for quality control.

The moisture content of each individual grain sample was determined by exposing 50 grams of whole grain in a thermostatically controlled forced draft oven for 72 hours at 220°F. The final moisture content in the bed was calculated from the initial moisture content and the weight loss due to evaporation of water was made under the assumption that the measured weight loss at the end of each run was due solely to the evaporation of H₂O, and the weight loss due to sampling for the determination of the moisture content by the oven method during drying.

A number of tests were conducted to obtain information on the results of mixing a bed of maize during drying. For example, beds of 4" deep and 6" deep maize were mixed with a hoe for about 5 minutes at intervals of 2 hrs and 4 hrs after the start of each drying trial. The mixing was done while the warm air was passing through the bed of drying grain. Just before each turning the bed was sampled at the top and bottom to determine the moisture gradient.

The total heat input during drying was calculated by weighing the total amount of wood used to dry corn at each drying trial. The heating value of wood used is considered to be 7,100 BTU/lb taken from Brooker et al. (1974). Since the grain temperatures at the beginning of each drying trial were different, the heat required to raise the temperature of the grain to the reference temperature, which was considered to be the average ambient temperature of 65°F, was taken into account. In calculating the results, it was assumed that the specific heat of maize is 0.531 BTU/lb °F (AFMA Handbook, 1976). Heat loss through the dryer walls was excluded.

Four main factors were examined with respect to drying rate, fuel efficiency and grain quality (moisture gradient). Table 2 describes the test numbers for each of the drying trials of both dryer models and their test conditions. It should be noted that each drying experiment at the specified test conditions was replicated once.

TABLE 2. Brief Description of All Drying Trials.

Unmodified Dryer

Test Number	Description
A-1, A-2	4" grain depth, turning of grain every 2 hrs., initial moisture content 25% (w.b.), full air inlet.
B-1, B-2	4" grain depth, turning of grain every 2 hrs., initial moisture content 20% (w.b.), full air inlet.
C-1, C-2	6" grain depth, turning of grain every 2 hrs., initial moisture content 25% (w.b.), full air inlet.
D-1, D-2	6" grain depth, turning of grain every 2 hrs., initial moisture content 20% (w.b.), full air inlet.
E-1, E-2	4" grain depth, turning of grain every 2 hrs. and every 4 hrs. respectively, initial moisture content 20% (w.b.), 1/2 air inlet.
F-1, F-2	4" grain depth, turning every 4 hrs., initial moisture content 20% (w.b.), full air inlet.
G-1, G-2	6" grain depth, turning every 4 hrs., initial moisture content 25% (w.b.), full air inlet, continuous drying.
H-1	4" grain depth, turning of grain every 4 hrs., initial moisture content 25% (w.b.), full air inlet.
I-1, I-2	4" grain depth, NO turning of grain, initial moisture content 25% (w.b.), full air inlet.
J-1, J-2	4" grain depth, turning of grain every 2 hrs., initial moisture content 25% (w.b.), full air inlet.

TABLE 2 (Contd.)

Modified Dryer

Test Number	Description
K-1, K-2	4" grain depth, turning of grain every 2 hrs., initial moisture content 25% (w.b.), full air inlet.
L-1, L-2	4" grain depth, turning of grain every 2 hrs., initial moisture content 20% (w.b.), full air inlet.
M-1, M-2	6" grain depth, turning of grain every 2 hrs., initial moisture content 25% (w.b.), full air inlet.
N-1, N-2	6" grain depth, turning of grain every 2 hrs., initial moisture content 20% (w.b.), full air inlet.
O-1, O-2	4" grain depth, turning of grain every 2 hrs. and 4 hrs. respectively, initial moisture content 20% (w.b.), 1/2 air inlet.
P-1, P-2	6" grain depth, turning of grain every 4 hrs., initial moisture content 25% (w.b.), full air inlet, continuous drying.
Q-1, Q-2	4" and 6" grain depth (respectively), turning of grain every 4 hrs., initial moisture content 25% (w.b.), full air inlet.
R-1, R-2	4" grain depth, turning of grain every 2 hrs., initial moisture content 20% and 25% (w.b.) respectively, full air inlet.
S-1, S-2	6" grain depth, turning of grain every 4 hrs., initial moisture content 25% and 20% (w.b.) respectively, full air inlet.
T-1	4" grain depth, turning of grain every 2 hrs., initial moisture content 20% (w.b.), full air inlet.
U-1	4" grain depth, NO turning of grain, initial moisture content 25% (w.b.), full air inlet.

TABLE 2 (Contd.)

Modified Dryer

Test Number	Description
V-1, V-2	4" grain depth, turning of grain every 4 hrs., initial moisture content 25% (w.b.), full air inlet.
W-1	4" grain depth, turning of grain every 4 hrs., initial moisture content 20% (w.b.), full air inlet.

RESULTS AND DISCUSSION

Forty-two drying trials were conducted, 19 with the unmodified dryer and 23 with the modified one. A total of 20 metric tons of maize were dried from an initial moisture content of either 20% or 25% (w.b.) down to 12% or 13% (w.b.).

The results of the airflow tests for the modified dryer were quite favorable. The range of the airflow rates (in cubic feet per minute per bushel) for the unmodified dryer with the maize at a 20% M.C. (w.b.), the depth at 4" and the relative humidity at 60% was from 4.69 cfm/bu to 6.82 cfm/bu with a mean airflow rate of 5.75 cfm/bu. For the modified dryer at the same moisture content, grain depth and average relative humidity, the range was from 5.16 cfm/bu to 9.06 cfm/bu with a mean airflow rate of 7.11 cfm/bu. Thus the mean airflow rate of the modified dryer was 24% higher than the mean airflow rate of the unmodified dryer.

Table 3 contains the experimental results for all the drying trials for both unmodified and modified dryers. The second column gives the initial moisture content of the drying beds of grain, M_0 , and the third column presents the final moisture content, M_f , or the point at which the drying trial was stopped. The fourth column gives the time it took to dry each trial from M_0 to M_f . The fifth column describes the total amount of water removed in pounds during the trials and the sixth contains the total amount of wood used in pounds for each individual trial. The drying rate is given in the seventh column in terms of pounds of water removed per hour and in the last column the fuel efficiency is given in terms of pounds of water removed per hour per pound of wood used.

TABLE 3. Experimental Results on Drying Rate and Fuel Efficiency for All Drying Tests.

UNMODIFIED DRYER

Test No.	M_o^*	M_f^*	Drying Time (hrs.)	lbs H ₂ O Removed	lbs Wood Used	lbs H ₂ O Removed hour	lbs H ₂ O Removed hr-lb wood
A-1	25.24	12.87	24.0	170.37	345.0	7.10	.021
A-2	24.92	13.21	26.0	161.91	332.5	6.23	.019
B-1	21.03	12.26	20.0	119.95	306.5	6.00	.020
B-2	22.87	12.81	22.0	138.46	279.5	6.29	.023
C-1	23.10	12.67	38.0	191.09	343.0	5.03	.015
C-2	24.27	13.89	34.0	192.87	357.5	5.67	.016
D-1	21.66	12.81	32.0	162.40	332.0	5.08	.015
D-2	22.04	13.34	34.0	160.63	325.0	4.72	.015
E-1	20.29	13.07	25.5	99.67	297.5	3.91	.013
E-2	21.29	12.22	29.0	123.99	338.5	4.28	.013
F-1	20.93	12.19	20.0	119.44	357.0	5.97	.017
F-2	20.24	13.10	22.0	98.60	380.0	4.48	.012
G-1	25.21	13.39	41.0	218.36	480.0	5.33	.011
G-2	24.15	13.05	38.0	204.26	240.0	5.38	.022
H-1	25.41	12.19	30.0	180.66	422.0	6.02	.014
I-1	24.96	12.78	40.0	167.58	468.5	4.19	.009
I-2	25.03	12.46	41.0	175.59	470.0	4.28	.009
J-1	23.09	12.13	26.0	149.68	343.7	5.76	.017
J-2	22.97	11.98	26.5	149.83	345.3	5.65	.016

*: Moisture Content, wet basis, in %.

TABLE 3 (Contd.)

MODIFIED DRYER

Test No.	M ₀	M _f	Drying Time (hrs.)	lbs H ₂ O Removed	lbs Wood Used	lbs H ₂ O Removed hour	lbs H ₂ O Removed hr-lb wood
K-1	24.47	12.91	20.0	159.28	235.0	7.96	.038
K-2	25.19	12.83	18.0	170.13	231.0	9.45	.041
L-1	21.03	11.80	16.0	125.58	207.0	7.85	.038
L-2	20.24	12.12	16.0	110.88	215.0	6.93	.032
M-1	24.04	12.44	30.0	211.97	292.5	7.07	.024
M-2	24.34	12.20	28.0	221.23	280.0	7.90	.028
N-1	21.17	12.95	26.5	151.09	258.5	5.70	.022
N-2	22.23	13.80	28.5	156.47	263.5	5.49	.021
O-1	21.89	13.81	21.0	112.50	210.0	5.36	.026
O-2	22.24	12.94	21.5	128.19	209.5	5.96	.028
P-1	25.21	12.15	28.0	237.86	324.0	8.50	.016
P-2	24.14	12.30	28.0	216.01	279.5	7.71	.028
Q-1	25.39	13.05	24.0	218.36	428.5	5.33	.011
Q-2	24.48	12.88	30.0	213.04	378.5	7.10	.019
R-1	22.10	12.50	16.0	131.66	200.0	8.23	.041
R-2	22.69	12.36	21.0	141.44	296.5	6.74	.023
S-1	26.38	10.62	14.0	204.26	292.5	5.38	.022
S-2	20.93	13.03	24.0	145.34	375.5	6.06	.016

TABLE 3 (Contd.)

MODIFIED DRYER

Test No.	M _o	M _f	Drying Time (hrs.)	lbs H ₂ O Removed	lbs Wood Used	lbs H ₂ O Removed / hour	lbs H ₂ O Removed / hr-lb wood
T-1	21.67	12.73	28.0	122.93	357.0	4.39	.012
U-1	24.87	12.37	35.0	171.17	275.5	4.89	.018
V-1	25.03	11.97	26.0	178.03	263.8	6.85	.026
V-2	24.86	12.41	25.0	170.57	264.7	6.82	.026
W-1	22.11	12.18	16.0	135.69	230.3	8.48	.037

Table 4 illustrates the effects of grain depth and the initial moisture content (w.b.) on the drying rate and the dryer and fuel efficiencies for both dryers. It should be noted that all the trials presented on this table were conducted with a full air inlet and with a turning time for the grain of every two hours.

The depth factors of 4" and 6" of grain presented in Table 4 reveal a difference in the performance of both dryers. In the modified dryer the average dryer efficiency (lbs of water removed/lb of wood used) was increased by 6.2% over the 4" depth but the 4" depth increased both the average drying rate (lbs of water removed/hr) and the average fuel efficiency (lbs water removed/hr/lb of wood used) by 23% and 54% respectively over that of the 6" depth.

The depth showed a similar relationship with the unmodified dryer. The 6" depth factor increased the average dryer efficiency by 12% over that of the 4" depth factor but the 4" depth factor increased the average drying rate by 25% and the average fuel efficiency by 40% over that of the 6" depth.

When the depth of grain is used in comparing the modified dryer with the unmodified dryer, then an obvious advantage can be seen. At a 4" depth the modified dryer depicted a 26% increase in the average drying rate, a 36% increase in the average dryer efficiency and a 76% increase in the average fuel efficiency over the unmodified at the same grain depth. With a 6" depth the modified dryer also improved its performance but to a lesser degree. The average drying rate and dryer efficiency increased by 28% and the average fuel efficiency increased by 60% over the unmodified dryer also at a 6" grain depth.

TABLE 4. Effects of Grain Depth and Initial Moisture Content on Drying Rate, Dryer and Fuel Efficiency.

Modified Dryer

Maize Depth	Initial Moisture Content	Test no.	Drying Time (hrs)	lbs H ₂ O Removed hr	lbs H ₂ O Removed lb wood used	lbs H ₂ O Removed hr - lb wood used
4"	25%	K-1	20.0	7.96	.676	.038
	25%	K-2	18.0	9.45	.737	.041
	20%	L-1	16.0	7.85	.607	.038
	20%	L-2	16.0	6.93	.516	.032
6"	25%	M-1	30.0	7.07	.725	.024
	25%	M-2	28.0	7.90	.790	.028
	20%	N-1	26.5	5.70	.584	.022
	20%	N-2	28.5	5.49	.594	.021

Unmodified Dryer

Maize Depth	Initial Moisture Content	Test no.	Drying Time (hrs)	lbs H ₂ O Removed hr	lbs H ₂ O Removed lb wood used	lbs H ₂ O Removed hr - lb wood used
4"	25%	A-1	24.0	7.10	.494	.021
	25%	A-2	26.0	6.23	.487	.019
	20%	B-1	20.0	6.00	.391	.020
	20%	B-2	22.0	6.29	.495	.023
6"	25%	C-1	38.0	5.03	.577	.015
	25%	C-2	34.0	5.67	.540	.016
	20%	D-1	32.0	5.08	.488	.015
	20%	D-2	34.0	4.72	.494	.015

Turning every 2 hours with full air inlet.

In general, it can be said that the 4" depth factor was important in increasing the performance of both dryers over the 6" depth factor in terms of drying rate and fuel efficiency. Only with the dryer efficiency did the 6" depth factor have a slight advantage over the 4" depth factor in both dryers. When the modified dryer was compared with the unmodified model at the same depth the results were unanimous. The modified dryer displayed its greatest efficiency over the unmodified model at the 4" depth in terms of drying rate, dryer efficiency and fuel efficiency. At the 6" depth the modified dryer was also more efficient in all the previously mentioned aspects but to a subordinate degree. The results from the statistical analysis showed a very small difference between a 4" and 6" depth factor on the dryers' performance most likely caused by too small a sample size because Table 4 illustrates that the 4" depth definitely has a slight advantage in relation to the drying rate and the fuel efficiency. Only with the dryer efficiency was there a slight advantage exhibited by the 6" depth. Therefore, it will be recommended that a 4" depth of maize be used in the dryers.

Also displayed in Table 4 are the effects of two initial moisture contents (20 and 25% w.b.) of the drying grain on the performance of the dryers. For the modified dryer the initial moisture content of 25% (w.b.) increased the average drying rate, dryer efficiency and fuel efficiency by 25%, 27% and 18% respectively over the initial moisture content of 20% (w.b.). A relative response occurred with the unmodified dryer where the average drying rate and dryer efficiency increased by 9% and 12% respectively over the trials with an initial moisture content of 20% (w.b.). There was no difference in the average fuel efficiency for the unmodified dryer for both initial moisture contents.

When comparing the modified dryer with the unmodified dryer at each initial moisture content (20 and 25% w.b.) the modified dryer noticeably outperformed the unmodified dryer in both instances. At the initial moisture content of 25% (w.b.) the modified dryer's performance increased by 35% for the drying rate, 40% for the dryer efficiency and 83% for the fuel efficiency over the unmodified model. At the initial moisture content of 20% (w.b.) the modified dryer again exhibited a better performance than the unmodified dryer but to a lesser extent than at the initial moisture content of 25% (w.b.). Here the modified dryer's performance increased by only 18% for the drying rate, 23% for the dryer efficiency and 56% for the fuel efficiency. Though the statistical analysis reveals that there is a small difference on the dryers' performance with either starting with an initial moisture content of 20% or 25% (w.b.), probably due again to too small a sample size, the tests in Table 4 exhibit a favor towards starting with 25%. Therefore, it will be recommended that an initial moisture content of 25% (w.b.) be used if possible.

The epitome of the results from Table 4 was that the grain depth of 4" and the initial moisture content of 25% (w.b.) had the greatest effect on the drying rate and the fuel efficiency of both dryers with a turning time of every 2 hours and a full air inlet. This same depth, initial moisture content, turning time and air inlet size also gave the modified dryer the highest drying performance in terms of fuel efficiency where it proved 76% more effective than the unmodified dryer under the same given conditions.

Figure 9 graphically illustrates the effect of the grain depth on the drying rate for both modified and unmodified dryers. Four drying

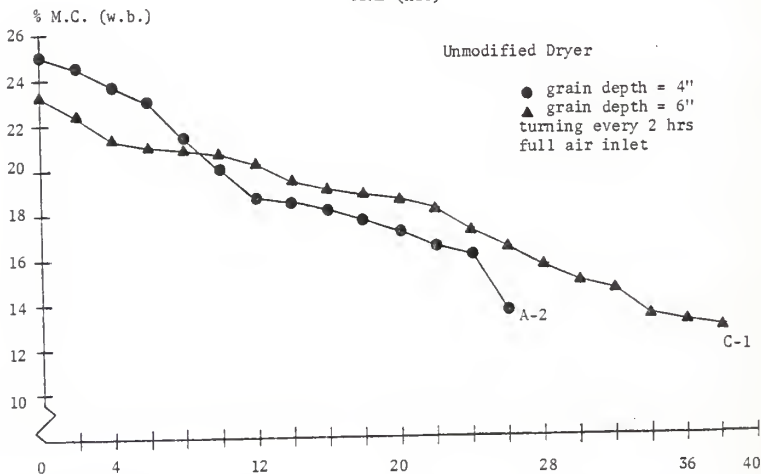
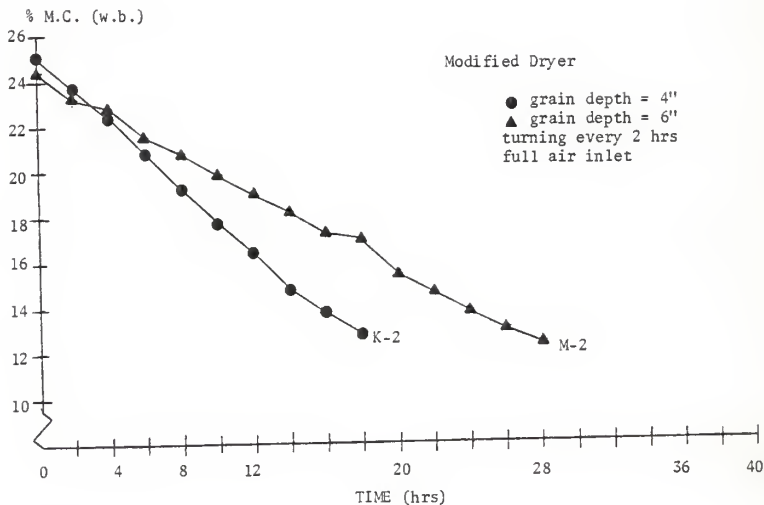

Figure 9. Effect of Grain Depth on Drying Rate for Both Modified and Unmodified Dryers.

trials were taken from Table 4 to give a visual presentation of how the different grain depths affected each dryer given an initial moisture content of 25% (w.b.), turning time of every 2 hours and a full air inlet.

The top half of Table 5 presents the effects of the turning time and the air inlet size on the drying time, drying rate and fuel efficiency for both modified and unmodified dryers at an initial moisture content of 20% (w.b.) and a grain depth of 4". The bottom half of Table 5 presents the effects of no turning and turning every 2 hours on the drying time, drying rate and fuel efficiency of both dryers at an initial moisture content of 25% (w.b.), a 4" grain depth and a full air inlet. The graphical presentations of typical drying trials showing the effects of turning time and air inlet size on the drying rate are shown in Figures 10 and 11 respectively:

As seen in Table 5, the effect of the turning time between every 2 hours and every 4 hours on the drying time, drying rate and fuel efficiency was not significant while the effect of the air inlet size was quite significant for both dryers.

For the drying rate, the modified dryer with a full air inlet and a turning time of every 2 hours was 54% more efficient than that with a turning time of every 4 hours and a 1/2 air inlet size. At a turning time of every 4 hours with the same dryer the full air inlet size gave a 42% increase over the 1/2 air inlet size with the same turning time. Thus the modified dryer provides the most efficient drying rate with a full air inlet and a 4 hours turning time at a 4" grain depth.

For the unmodified dryer with a turning time of every 2 hours the full air inlet trial gave a 54% more efficient drying rate than the 1/2

TABLE 5. Effects of Turning Time and Air Inlet Size on Drying Rate and Fuel Efficiency.

Modified Dryer						Unmodified Dryer					
[4" depth and $M_0 = 20\%$ (w.b.)]						[4" depth and $M_0 = 20\%$ (w.b.)]					
Air Inlet	Test No.	Turning (hrs)	Drying Time (hrs)	lbs H_2O Removed/hr	lbs H_2O Removed/hr - lb wood used	Air Inlet	Test No.	Turning (hrs)	Drying Time (hrs)	lbs H_2O Removed/hr	lbs H_2O Removed/hr - lb wood used
Full	R-1	2	16.0	8.23	.041	Full	B-1	2	20.0	6.00	.020
	W-1	4	16.0	8.48	.037		F-1	4	20.0	5.97	.017
1/2	O-1	2	21.0	5.36	.026	1/2	E-1	2	25.5	3.91	.013
	O-2	4	21.5	5.96	.028		E-2	4	29.0	4.28	.013
Modified Dryer						Unmodified Dryer					
[4" depth and $M_0 = 25\%$ (w.b.)]						[4" depth and $M_0 = 25\%$ (w.b.)]					
Full	U-1	None	35.0	4.89	.018	Full	I-1	None	40.0	4.19	.009
	K-2	2	18.0	9.45	.041		A-2	2	26.0	6.23	.019

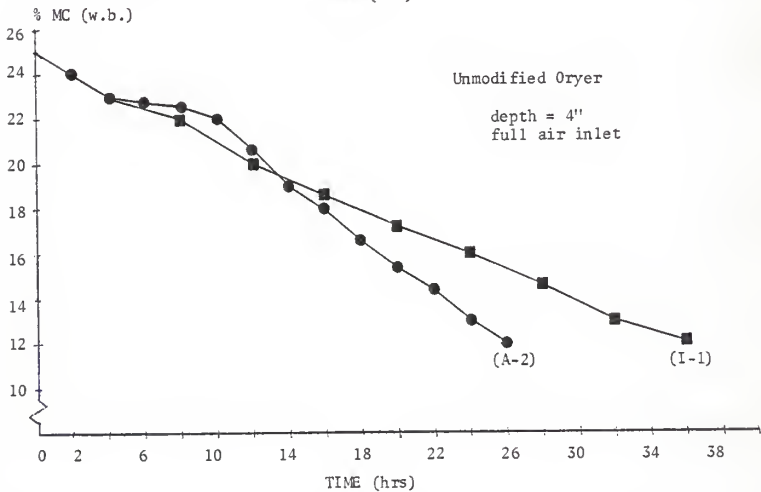
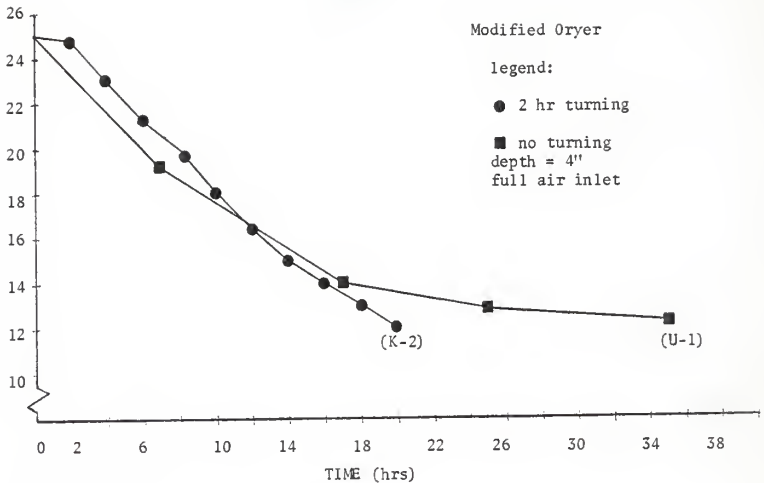

Figure 10. Effect of Turning Time on Drying Rate for Both Unmodified and Modified Dryers.

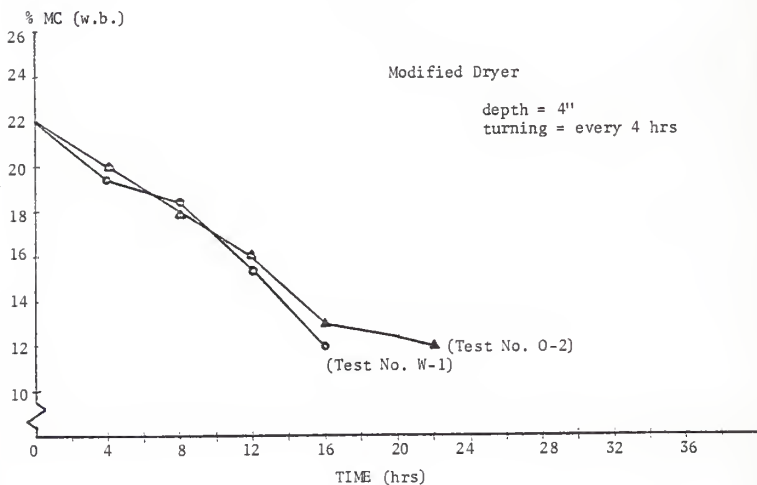
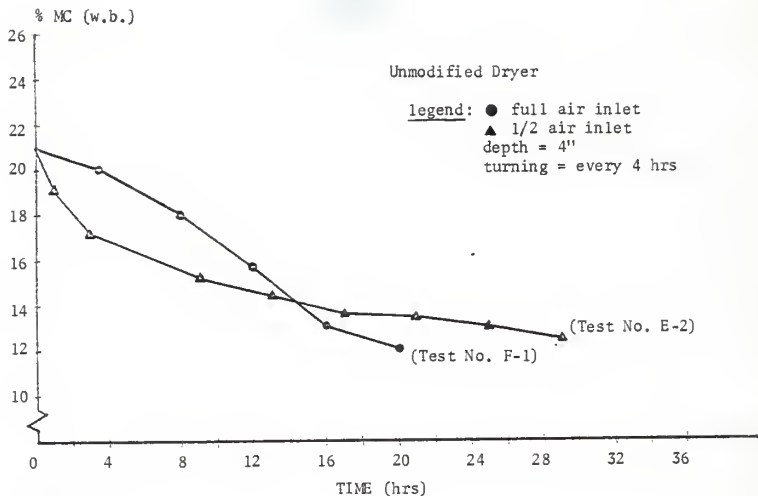

Figure 11. Effect of Air Inlet Size on Drying Rate for Both Unmodified and Modified Dryers.

air inlet trial. At a 4 hour turning time the full air inlet trial gave a 40% more efficient drying rate than the 1/2 air inlet trial. Thus the highest drying rate with the unmodified dryer was achieved with a full air inlet and with a turning time of every 2 hours as opposed to the modified dryer that had its highest achieved drying rate with a turning time of every 4 hours. The drying rate of the modified dryer was 41% more efficient using a full air inlet and turning the grain every 4 hours than the unmodified dryer with a full air inlet and turning the grain every 2 hours.

The bottom section of Table 5 illustrates the effect of no turning versus turning every 2 hours on the drying time, drying rate and fuel efficiency for both dryers with a grain depth of 4", a 25% initial moisture content and a full air inlet size. The results were extremely favorable in that the modified dryer improved its performance by turning the grain by 94% for the drying time (hrs), 93% for the drying rate (lbs water removed/hr), and more than 100% for the fuel efficiency (lbs of water removed/hr/lb of wood used).

Turning the grain versus no turning the grain with the unmodified dryer depicted a much smaller effect with the drying time and drying rate where the turning effect improved the performance of the dryer by 50% over the no turning, but note that again the fuel efficiency increased by more than 100% simply by turning the grain every 2 hours instead of no turning (which is the current practice used with the unmodified dryer).

The most phenomenal differences occurred when comparing the modified dryer in conjunction with turning with the unmodified dryer as it is presently being used (no turning). The modified dryer depicted a better

than 100% improvement over the unmodified dryer in terms of drying time, drying rate and fuel efficiency. In general, it may then be said that not only does the turning time improve the fuel efficiency of each dryer by 100% but it also depicts a tremendous improvement of the modified dryer over the unmodified dryer (100%) in conjunction with the drying time, drying rate and fuel efficiency. These results had a major influence on the recommendations given for using the modified dryer in the conclusion.

Typical results on the grain temperature and the plenum air temperature variations during the drying tests at different turning times are shown in Figure 12 for the modified dryer and in Figure 13 for the unmodified dryer. Both figures reveal some differences in temperature variations between turning times. However, it should be noted that these variations are attributed not by the turning time alone but also by the fueling time and amount. As examples, the drying tests with no turning and turning every 4 hours show limited temperature variations as opposed to turning every 2 hours. This is mainly due to even heat distribution resulting from a more regulated fuel feeding.

In general, the grain temperature gradients with the grain beds in the modified dryer appeared to be smaller than in the unmodified dryer. The grain temperatures never exceeded 60°C (140°F) even though the plenum air temperatures at times exceeded 60°C. It should be mentioned that the drying trials with the unmodified dryer should be watched much more carefully than with the modified dryer by reason that the drying temperatures in the unmodified dryer easily inclined to exceed a safe drying temperature (60°C).

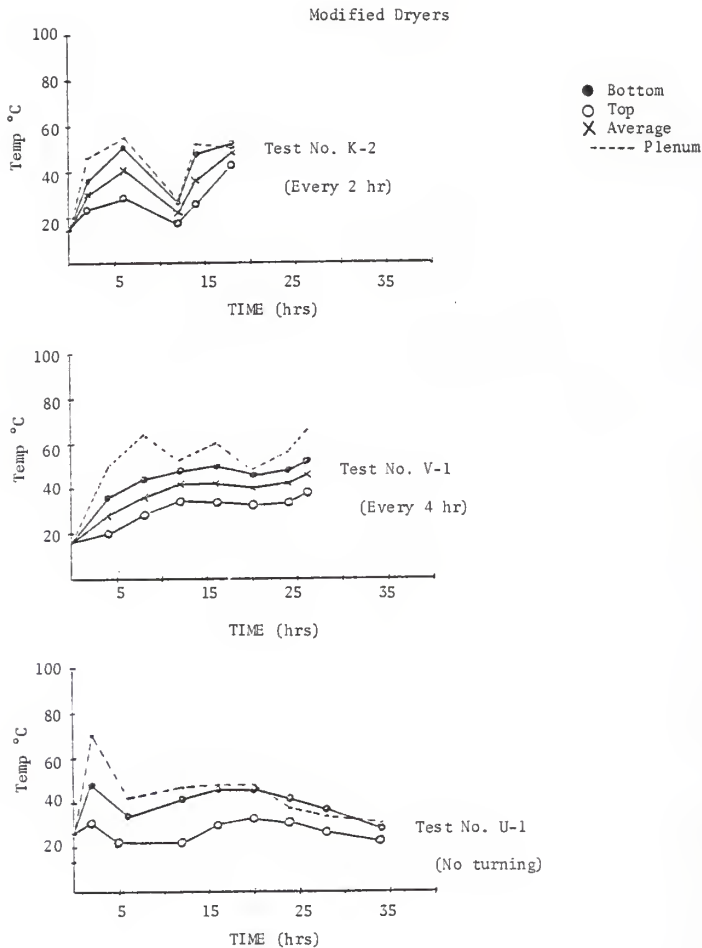

Figure 12. Temperature Variations of Drying Tests for Modified Dryer.

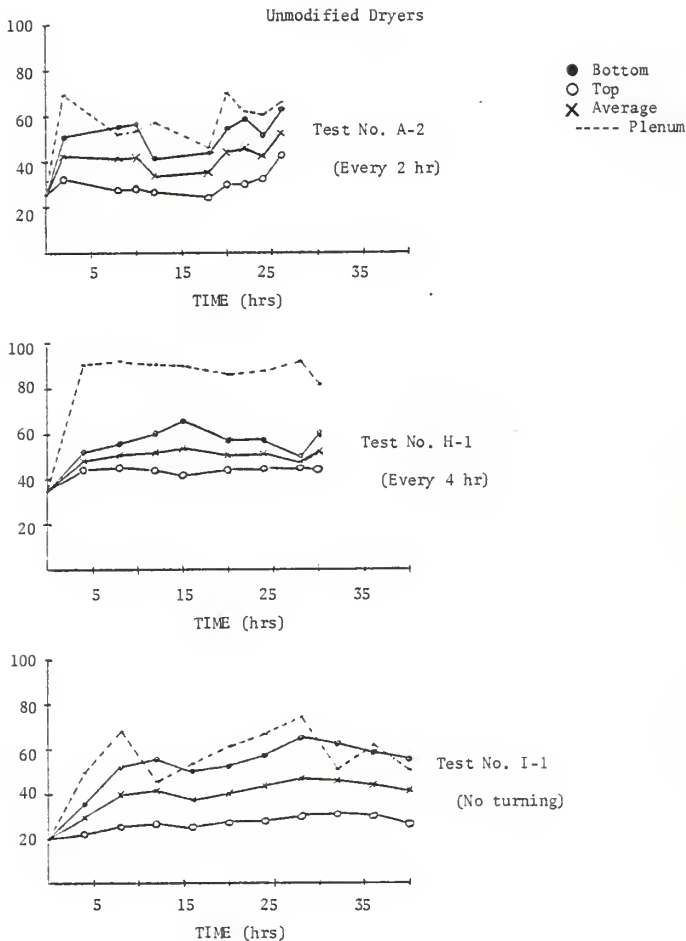

Figure 13. Temperature Variations of Drying Tests for Unmodified Dryer.

The effect of turning the grain versus no turning on the grain quality, in terms of moisture gradient, and on the drying rate can be seen in Figure 14, for the modified dryer, and in Figure 15, for the unmodified dryer. The standard parameters for both figures are: a 4" grain depth, a full air inlet and a 25% initial moisture content (wet basis) for all the drying trials.

The top portion of Figure 14 illustrates the moisture gradient in maize after 35 hours of drying using the modified dryer with no turning and an initial moisture content of 25% (w.b.) and ending with an average final moisture content of 13% (w.b.). There is a moisture content difference of 14% between the bottom portion ($\approx 6\%$ (w.b.)) of the grain and the top portion (20% (w.b.)) at the end point of drying. The bottom portion of the grain is obviously over dried and the top portion is too wet for safe storage.

The lower section of Figure 14 shows the moisture gradient in grain dried with the modified dryer under the same conditions except there is a turning rate of every 2 hours instead of no turning. The same quantity of grain was dried in 18 hours using the 2 hour turning rate. At the end of this drying trial, the top portion of the grain had a moisture content of 14% (w.b.) while the bottom portion had a moisture content of 12% (w.b.). Not only was the moisture gradient for the 2 hour turning rate trial reduced by 86% over the no turning trial but the drying rate (lbs water removed/hr) was increased by 95%.

For the unmodified dryer (Figure 15) the differences were more acute. It took 40 hours to dry 1200 lbs (4") of maize from an initial moisture content of 25% (w.b.) to an "average" final moisture content of

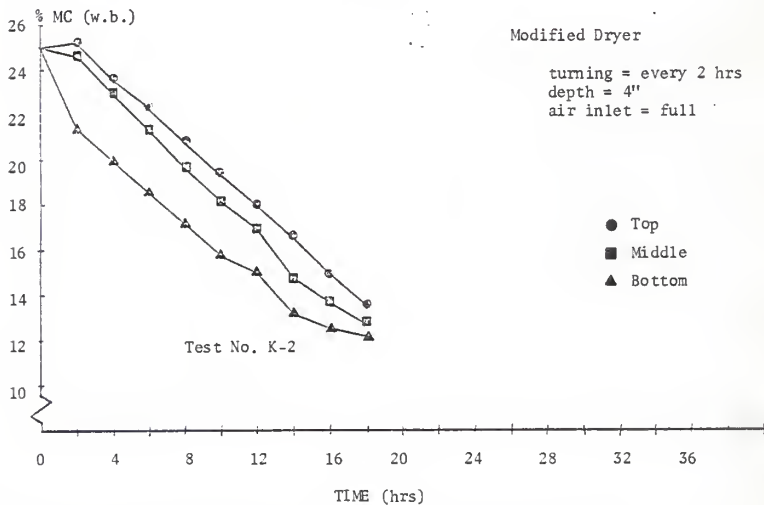
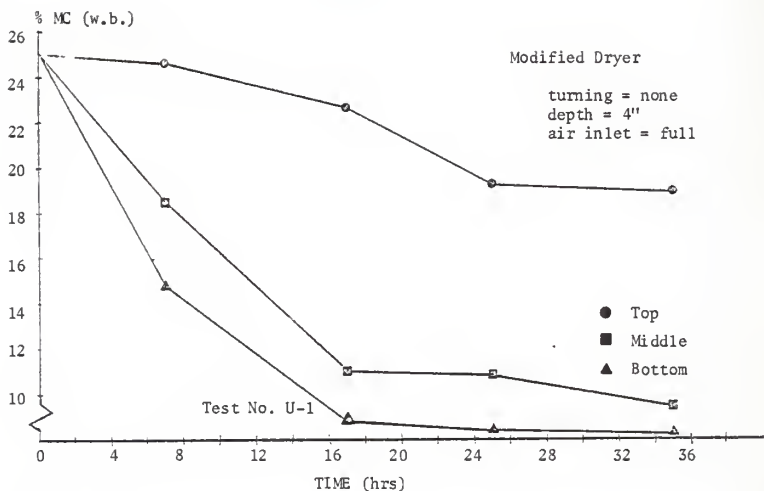

Figure 14. Moisture Distribution in Grain Bed in Modified Dryer.

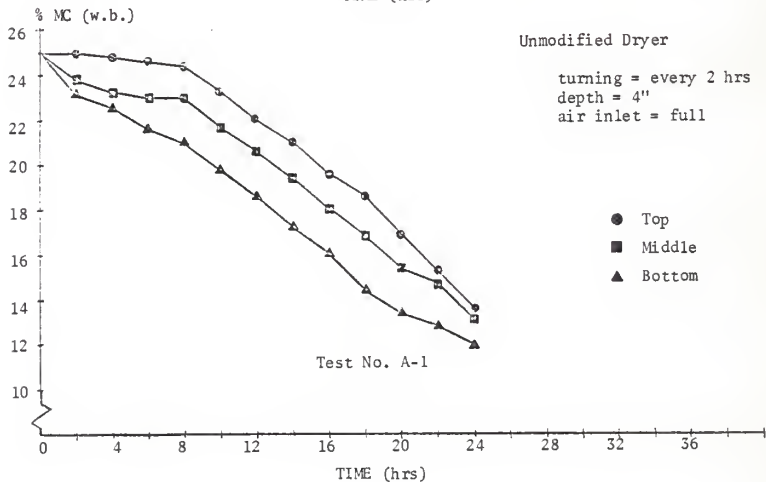
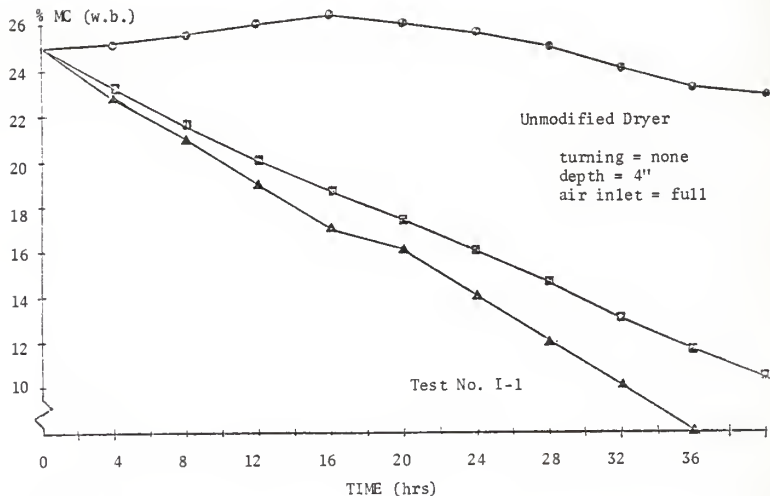

Figure 15. Moisture Distribution in Grain Bed in Unmodified Dryer.

13% (W.B.). Figure 15 (top) depicts a moisture content difference from the top of the grain bed to the bottom of 20% (w.b.) at the end of the drying trial. Just by turning the grain bed every 2 hours not only was the drying time reduced from 40 to 24 hours but the moisture gradient was reduced from 20% to 2%. Consequently, not only was the grain quality improved by reducing the moisture gradient by more than 100% but the drying rate (lbs water removed/hr) was increased by 67%. By comparing the modified dryer (with turning) with the unmodified dryer as it is presently being used (no turning), a greater than 100% improvement in the drying rate and in the moisture gradient (grain quality) is observed in the modified model over the unmodified one.

An extra parameter that was tested, but not part of the objectives of this research, was the effect of continuous drying; that is, the drying of grain from one batch to another without allowing the plenum chamber to cool (maintaining a continuous fire). Two trials for each dryer were tested with the second trial being the "continuous" trial of the first. With the unmodified dryer's trials (G-1 and G-2 on Table 2) at a grain depth of 6", a turning time of every 4 hours and a full air inlet, the fuel efficiency was improved by 100% while the modified dryer's trials (P-1 and P-2 on Table 2) at the same grain depth, turning time and inlet size had an improved fuel efficiency of 75%. Though not statistically proven this is a good parameter to investigate further in future work.

In addition to the fuel efficiency, the actual dryer (thermal) efficiency was calculated by using the following constant values:

- a) heat of vaporization of water in grain = 1500 BTU/lb
- b) heat content of wood used = 7100 BTU/lb.

The dryer (thermal) efficiency for the drying trials of the unmodified dryer ranged from 8% to 12% with the highest efficiency by using an initial moisture content of 25% (w.b.), a grain depth of 6", a full air inlet size and a turning time of every 2 hours while the lowest efficiency was obtained with an initial moisture content of 25% (w.b.), a grain depth of 4", a full air inlet size and with no turning of the grain.

The dryer (thermal) efficiency for the drying trials of the modified dryer ranged from 11% to 17% with the highest efficiency obtained with an initial moisture content of 25% (w.b.), a grain depth of 6", a full air inlet size and a turning time of every 2 hours.

In general, the dryer efficiency with the modified dryer increased more than 100% over that of the unmodified dryer using current drying practices.

Supplementary to the above analysis, the results were analyzed statistically by using the "SAS" computer program. These results are shown in Tables 6 and 7. Table 6 contains the results of the analysis of variance for examining the types of dryers, grain depths, turning times, and initial moisture contents on the drying rate. The significant effects occurred between the types of dryers. Among all the main factors and their interactions examined, only the type of dryer effect was significant at $\alpha = .05$.

Table 7 contains the analysis of variance for examining the effects of the modified dryer versus the unmodified dryer, the turning times and the 1/2 air inlet size versus the full inlet size on the drying rate. The results show that only the effect of the dryers and the inlet sizes were significant at $\alpha = .05$ among the main factors and their interactions tested.

TABLE 6. Analysis of Variance for Examining Various Factors Based on the Drying Rate.

- A) 2 types of dryers (Mod, Unmod)
 2 different grain depths (4", 6")
 2 different turning rates (2 hrs, 4 hrs)
 2 initial moisture contents (W.B.) (25%, 20%)

B) Dependent variable: lbs H₂O removed/hour

Source	Degrees of Freedom	Sum of the Squares	F Value	PR > F
Dryer	1	7.56677	8.32	0.034*
Depth	1	0.00823	0.01	0.928
Turning	1	1.07251	1.18	0.327
(IMC)	1	0.36980	0.41	0.552
Dryer vs. Depth	1	0.75279	0.83	0.405
Dryer vs. Turning	1	0.24189	0.27	0.628
Dryer vs. Init. H ₂ O	1	0.05991	0.07	0.808
Depth vs. Turning	1	0.26036	0.29	0.616
Depth vs. IMC	1	5.16811	5.68	0.063
Turning vs. IMC	1	0.53561	0.59	0.478
ERROR	5	4.54797		

*level of significance ($\alpha=0.05$)

IMC = initial moisture content

TABLE 7. Analysis of Variance for Examining Various Factors Based on the Drying Rate.

A) Modified vs. Unmodified

Turning every 2 hrs vs. every 4 hrs

1/2 Air Inlet vs. Full Air Inlet

B) Dependent variable: lbs H₂O removed/hour

Source	Degrees of Freedom	Sum of the Squares	F-Value	PR > F
Dryer	1	7.0125	303.41	0.0365*
Turning	1	0.3081	13.33	0.1702
Inlet	1	9.6580	417.87	0.0311*
Dryer vs. Inlet	1	0.1891	8.18	0.2141
Dryer vs. Turning	1	0.0990	4.28	0.2865
Inlet vs. Turning	1	0.0171	0.74	0.5477
ERROR	1	0.0231		

*level of significance ($\alpha=0.05$)

An attempt was made to describe the drying curves for the movement of moisture through the drying bed of maize for all the drying trials. Since it was already known that all cereal grains follow a falling rate curve (Brooker, Bakker-Arkema, Hall, 1974), two curve fittings were applied to see which would have the best description of the falling rate for maize using the data from the modified and unmodified natural convection dryer trials from this investigation.

The two equations tested were as follows:

$$1) Y = Ae^{-Bx} \quad (\text{exponential})$$

$$2) Y = A - Bx \quad (\text{linear})$$

where $Y = \frac{M - M_e}{M_0 - M_e}$: the moisture ratio.

M = instantaneous moisture content at any time, x , in % moisture content, wet basis.

M_e = equilibrium moisture content, in % moisture content, wet basis.

M_0 = initial moisture content of grain in % moisture content, wet basis.

x = drying time in hours.

A and B = drying constants.

The analysis showed the Equations 1 and 2 fitted the experimental data very well. However, Equation 2 gave a much better fit. This can be seen in Table 8 for Equation 2 and in Table 9 for Equation 1. Table 8 displays the constants A and B in Equation 2, the standard error of the Y estimates and the R^2 values calculated for each trial. The R^2 values ranged from .860 to .999 for fitting the drying tests of this research with Equation 2.

TABLE 8. Regression Analysis of Drying Tests

Linear Regression

$$\frac{M - M_e}{M_o - M_e} = A - Bx$$

Unmodified Dryer

Test No.	Constant A	Constant B	Standard Error of Y Estimate	R ²
A-1	1.065	0.041	0.055	0.970
A-2	0.967	0.034	0.058	0.999
B-1	1.188	0.065	0.097	0.949
B-2	0.959	0.048	0.057	0.972
C-1	1.011	0.026	0.047	0.976
C-2	0.928	0.026	0.041	0.978
D-1	1.032	0.029	0.061	0.964
D-2	1.025	0.030	0.023	0.994
F-1	1.100	0.037	0.109	0.860
F-2	1.000	0.043	0.022	0.995
G-1	1.105	0.024	0.062	0.962
G-2	1.091	0.291	0.066	0.970
H-1	0.971	0.027	0.065	0.951
J-1	1.244	0.045	0.060	0.970

TABLE 8. (Contd.)

Modified Dryer

Test No.	Constant A	Constant B	Standard Error of Y-Estimate	R ²
K-1	0.979	0.053	0.067	0.969
K-2	1.008	0.059	0.012	0.956
L-1	0.977	0.062	0.034	0.989
L-2	0.973	0.062	0.015	0.998
M-1	0.897	0.033	0.051	0.972
M-2	0.955	0.035	0.015	0.997
N-1	1.120	0.040	0.040	0.986
N-2	0.944	0.033	0.054	0.966
P-1	0.974	0.040	0.047	0.985
P-2	0.883	0.029	0.079	0.923
Q-1	0.940	0.039	0.047	0.980
Q-2	0.981	0.036	0.076	0.962
R-1	1.012	0.061	0.053	0.973
R-2	0.972	0.049	0.039	0.987
S-2	1.106	0.043	0.106	0.937
V-1	0.945	0.036	0.043	0.980
W-1	0.928	0.068	0.099	0.949

TABLE 9. Regression Analysis of Drying Tests

Exponential Form

$$\frac{M - M_e}{M_0 - M_e} = A e^{-Bx}$$

Unmodified Dryer

Test No.	Constant A	Constant B	Standard Error of Y Estimate	R ²
A-1	1.384	0.091	0.178	0.835
A-2	1.075	0.063	0.038	0.849
B-1	2.435	0.218	0.575	0.742
B-2	1.246	0.122	0.099	0.972
C-1	1.539	0.072	0.219	0.749
C-2	1.370	0.078	0.167	0.677
D-1	1.633	0.083	0.248	0.790
D-2	1.429	0.074	0.164	0.849
F-1	1.173	0.053	0.152	0.799
F-2	1.087	0.074	0.075	0.943
G-1	1.309	0.044	0.144	0.889
G-2	1.461	0.067	0.193	0.921
H-1	1.151	0.057	0.127	0.836
J-1	1.510	0.076	0.165	0.868

TABLE 9. (Contd.)

Modified Dryer

Test No.	Constant A	Constant B	Standard Error of Y Estimate	R ²
K-1	1.582	0.176	0.225	0.940
K-2	1.326	0.142	0.146	0.986
L-1	1.253	0.149	0.139	0.874
L-2	1.207	0.141	0.108	0.919
M-1	1.243	0.095	0.095	0.939
M-2	1.290	0.089	0.123	0.885
N-1	1.528	0.088	0.185	0.858
N-2	1.404	0.086	0.187	0.682
P-1	1.368	0.115	0.182	0.920
P-2	0.978	0.059	0.065	0.911
Q-1	1.079	0.082	0.067	0.940
Q-2	1.380	0.103	0.171	0.943
R-1	1.324	0.144	0.180	0.774
R-2	1.413	0.140	0.167	0.908
S-2	1.808	0.129	0.416	0.761
V-1	1.039	0.067	0.048	0.960
W-1	1.054	0.154	0.078	0.952

Figure 16 illustrates the results of curve fitting three drying tests by using the linear regression equation (Equation 2).

The results of the linear regression analysis along with the results shown in Figure 14 definitely indicate that the drying tests undertaken with the modified and unmodified dryers can be described by Equation 2.

In summary, the major accomplishments achieved by this investigation were as follows:

- I. Among the four main factors studied, the effects of turning the grain and using a full air inlet were more pronounced than the effects of the initial moisture content and the grain depth on the following parameters:
 - a) drying rate,
 - b) fuel efficiency,
 - c) dryer efficiency.
- II. A considerable improvement of the drying performance of the modified dryer over the unmodified model with current drying procedures was observed:
 - a) the moisture gradient was virtually eliminated,
 - b) the drying performance was increased by more than 100% in terms of the drying rate (capacity), the fuel efficiency and the dryer efficiency,
 - c) the mean airflow rate was improved by 24% (cfm/bu),
 - d) safer drying temperatures could more easily be maintained.

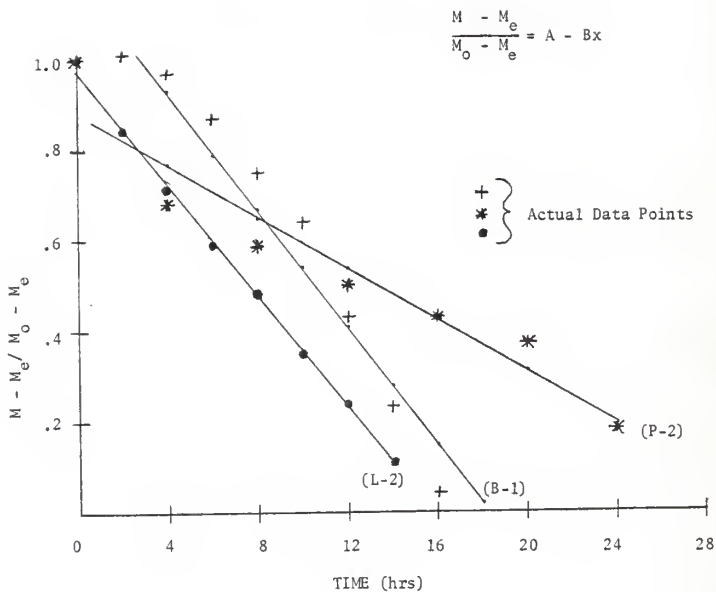

Figure 16. Linear Regression Plots of Drying Tests for Trial Numbers (B-1) Unmodified Dryer, (L-2) and (P-2) Modified Dryer.

CONCLUSIONS

From the results obtained from this investigation, the following conclusions were drawn:

1. Though the statistical analysis showed that the effect of the initial moisture content on the drying performance was small, an advantage of drying grain with an initial moisture content of 25% (wet basis) was observed with respect to the drying rate, the dryer efficiency and the fuel efficiency.
2. The statistical analysis also showed that the effect of using either a 4" or 6" grain depth on the drying performance was very small, but again the drying tests showed that the dryers performed slightly better at a 4" depth than at a 6" depth in terms of drying rate and fuel efficiency.
3. The turning methods definitely improved the drying performance of both dryers in terms of drying rate, dryer (thermal) efficiency, fuel efficiency and grain quality (moisture gradient reduction) as opposed to no turning. However, there was statistically no difference between turning the grain every 2 hours and every 4 hours.
4. With a full air inlet the drying performance in terms of drying rate, dryer efficiency, fuel efficiency and temperature variations were considerably improved.
5. The drying performance of both dryers in terms of fuel efficiency can further be increased by as much as 50%

simply by continuously drying from one batch of grain to another.

6. There was a 24% improvement of the airflow rate (cfm/bu) of the modified dryer over the unmodified model because of physical modifications made on the unmodified dryer:
 - a) wedged flue trench,
 - b) enlarged air inlet, and
 - c) increased drying floor height.

7. There was a 100% increase in the dryer efficiency, fuel efficiency and grain quality (moisture gradient) of the modified dryer over the unmodified dryer with current drying procedures by using the following recommended practices:
 - a) grain depth of 4"
 - b) turning rate of every 4 hours
 - c) full air inlet size
 - d) initial moisture content of 25% (wet basis), if possible.

8. The drying of maize in both dryers can be described by the following equation:

$$\frac{M - M_e}{M_o - M_e} = A - Bx$$

REFERENCES

- Adesuyi, S. A. and A. U. Patel. 1975. Crib storage of maize under tropical village conditions in the Ibadan area of Nigeria. London, England. Tropical Stored Products Information.
- Brook, J. A. 1964. A cheap crop dryer for the farmer. Tropical Stored Products Information. (7):257-26B.
- _____. 1964. A cheap crop dryer for the farmer: Results and recommended design. Tropical Stored Products Information. (B):301-307.
- Brooker, Bakker-Arkema and Hall. 1974. Drying Cereal Grains. 301-336.
- Bournville. 1958. The Samoan cocoa dryer. Birmingham, England. Canbury Bros.
- Brownell, W. E. 1976. Structural Clay Products. New York. 2-5.
- Chancellor, W. J. 1968. A simple grain dryer using conducted heat. Transactions of the American Society of Agriculture Engineers. 11(6):857-862.
- Christensen, C. M. 1974. Storage of cereal grains and their products. American Association of Cereal Chemists. 333-360, 481-501.
- Chung, D. S. and L. F. Fleske. 1973. Development of a simple grain storage unit and method applicable to humid areas. Food and Feed Grain Institute, Kansas State University. 25-56.
- Chung, D. S. and H. B. Pfof. 1967. Absorption and desorption of water vapor by cereal grains and their products. Part II: Development of the general isotherm equation. Trans. of ASAE 10(4):553-556.
- Corbett, G. G. 1973. Grain handling systems for the lowland tropics. Tropical Stored Products Information (25):10-14.
- Darrow and Rick. 1976. Appropriate Technology Sourcebook. Washington, D.C.:10-30.
- Hall, D. W. 1970. Handling and storage of food grains in tropical and subtropical areas. FAO paper no. 90.
- Henderson, S. M. and R. L. Perry. 1976. Agricultural Process Engineering. Third edition: 300.
- Holmes, E. S. and R. I. Lipper. 1974. Low temperature grain drying. Cooperative Extension Service, Kansas State University.

- Johnson, H. K. and A. C. Dale. 1954. Heat required to vaporize moisture. *Agricultural Engineering*. St. Joseph, Michigan. 35(10):705.
- Lindblad, C. and D. Laurel. 1976. Small farm grain storage. Washington, D.C. Action/Peace Corps.
- Lindblad, C., M. Newman and R. Vinita. 1974. Construction manual for the mud-walled grain dryer. Cotonou, Benin.
- Matthes, R. K., G. Borns-Welch, J. C. Delouche and G. M. Dougherty. 1969. Drying, processing and storage of corn seed in tropical and subtropical regions. ASAE paper no. 59.
- Muckle, T. R. and H. G. Stirling. 1971. Review of the drying of cereals and legumes in the tropics. *Tropical Stored Products Information* (22).
- Pedersen, J. R. 1976. The fundamentals of grain storage (lecture notes). Kansas State University.
- Ryu, Kwan Hee. 1976. Factors affecting drying performance of a natural convection dryer for developing countries. Master's Thesis. Kansas State University.
- Schumacher, E. F. 1975. Small is beautiful. New York:169-179.
- Webb, E. R. 1969. A crop dryer and grain storage silo for the small farm. Ministry of Agriculture and Natural Resources, Ibadan, Nigeria.
- Wheatley, P. E. 1973. The maize storage problem in the less developed countries of Africa. *Chemistry and Industry*, London. 1049-1052.
- Woodforde, J. and P. J. Lawton. 1965. Drying cereal grains in beds six inches deep. *Journal of Agriculture Engineering Research*. 10(2):146-171.

APPENDIX

PROCEDURE FOR CONSTRUCTION OF
MODIFIED DRYER

I. Tools and Materials

- 3 empty oil barrels (55 gallon capacity each)
- 150 ft² chicken wire
- 33 ft of rebar (reinforcing armature)
for lintels (rebar $\emptyset = 3/8''$)
- materials for making lintels;
6 - 90 lb sacks of Sakrete - Concrete mix
- 50 ft of tying wire
- 10 logs (heat resistant) for drying floor
 $\emptyset = 4'' \times 4''$
l = 8'
- 2 strips of small mesh screen each about 6' long
and 8" wide
- digging tools
- 15 yd³ of good quality clay (Kaolinite)
- plentiful source of water

II. Manpower

(1 working day = 8 hrs)

- | | |
|-----------------------------|------------------|
| 1) digging hole | 6-8 man days |
| 2) preparing adobe (banco) | 6-8 man days |
| 3) mounting the walls | 9-12 man days |
| 4) placing the barrels | 1 man day |
| 5) placing the drying floor | <u>1 man day</u> |

Total = 21-30 man days

III. Select a Site

* Find a well-drained site where the water table never rises higher than 7 feet below ground level. Be sure that the topography allows you to have the stoking-pit hole of the dryer facing the predominant wind direction. Be careful not to place the dryer in natural runoff areas.

IV. Construct 2 Lintels

These are concrete horizontal slabs that will support the weight of the walls over the barrels. Logs may easily replace concrete if more appropriate for the region of construction.

1 chimney lintel: 4' x 1' x 4"

1 stoking-pit lintel: 6' x 1' x 4"

1) Make 2 molds (forms), one for each of the lintels. This can be done either with wood or by digging their dimensions out of the soil. Line either form well with left-over paper saved from cement sacks.

2) Cut the rebar into 6 pieces;

3 pieces at 6 ft

3 pieces at 4 ft.

Bend a hook into each end to minimize expansion of cement during curing.

3) Mix Sakrete in given proportions but if using Portland Cement, then mix as follows;

1 part cement

2 parts sand

3 parts gravel

Mix sand and cement thoroughly, then mix in gravel. Finally add just enough water to make the mixture workable but not watery.

- 4) Pour concrete mixture into lintel forms up to a level of 2" and tamp.
- 5) Lay 3 of the rebar pieces in each of their respective forms. Space them evenly and equidistant from one another with their hooked ends lying horizontally on the tamped mixture.
- 6) Finish pouring remaining 2" of concrete, tamp firmly, then level.
- 7) Keep both lintels wet for the next 7 days to insure slow curing of the cement thereby maximizing its potential strength.

V. Shelter

Construct a good shed roof to protect at least the area to be used for the dryer. If possible build it large enough to also protect a small storage unit or two. Be sure that the dryer's stoking-pit is free to prevailing winds. It is better to put any additional space for storage on the downwind area of the dryer.

VI. Drainage Ditches

* It is very important to dig good drainage ditches around the shelter to assure at least ample run-off capacity not only from the shelter roof but also to handle run-off from surrounding land. This should be done before digging of dryer hole begins.

VII. Staking of Dryer

Stake out the drying chamber and the stoking pit.

- 1) Stake out the drying chamber as shown in the following diagram (10' x 10').
- 2) Be sure to place the chimney on the downwind side to assure that smoke will not be blown back into the grain.
- 3) Place the stoking pit (as shown) in the direction of the prevailing winds. This will assure that there is ample draft for the fire. (see figure #1)

Figure #1

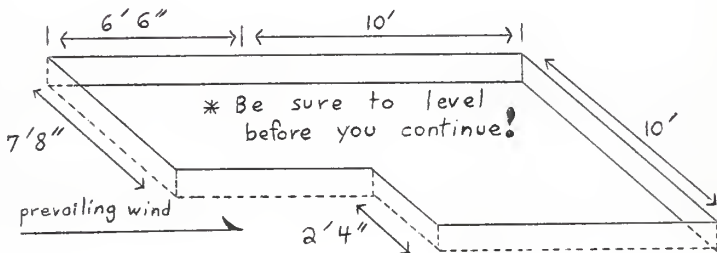

VIII. 1st Diggings

Dig the soil out of the staked-out area to a depth of 1 foot. (Be sure to separate organic matter from good clay soil since you should pile the clay by itself to be used later for the adobe (banco) walls.)

IX. Trench

Dig a trench in the center of the staked-out area as follows;
(see figure #2)

Figure #2

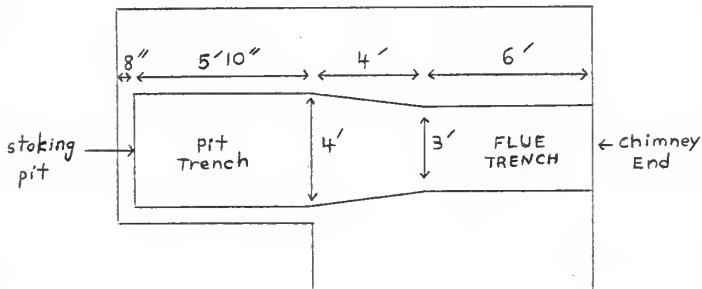

- 1) This trench should be 3' wide at the chimney end and extend 15'10" to the stoking-pit end which is 4' wide. 8" should remain around the stoking-pit trench for the retaining wall base. Notice the slope of the trench floor begins 6' from the chimney end and extends to the front of the dryer before straightening into the stoking-pit floor. This is well illustrated in a side-view diagram in the back of this manual.
- 2) Again be sure to save the good clay by separating it into a single pile apart from the organic top soil.

X. Shaping of Trench

- 1) Dig the entire trench 6'7" deep but once you get down to the 4'3" depth be sure to dig your lintel slots (shelves) before

digging the rest of the way down. The lintel slots should appear as follows; (see figure #3)

Figure #3

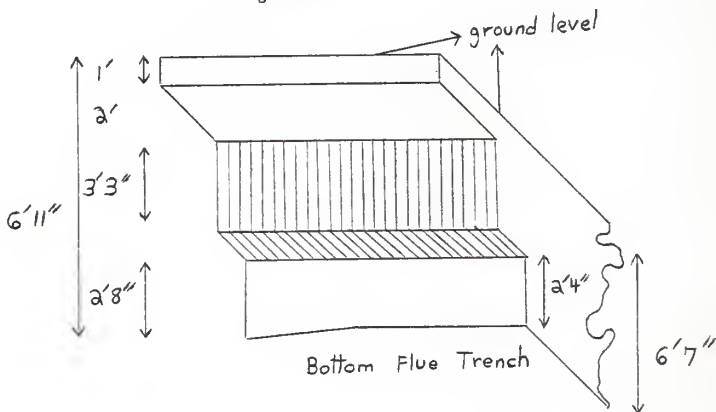

- 2) Mark the points where the dryer ends and the stoking-pit begins (10' from chimney). This should be the extent of your lintel slots (shelves).
- 3) The trench should be 2'4" below the lintel shelves at the chimney end and 2'8" below the lintel shelves at the stoking-pit end. * The only part of the trench floor that is sloped is the part from 6' to 10' from the chimney end. Also remember that your 6' lintel will be placed at the stoking-pit end and the 4' lintel will be placed at the chimney end. Therefore be sure to adjust shelves accordingly.

XI. Cut-outs for Chimney

Be sure you place this chimney cut-out in the center of the trench. The 6" x 6" x 4' cut-out is the smoke outlet trench while the 1' x 1' x 1' cut-out will serve as the foundation for the actual chimney with the smoke outlet trench extending through its center. (see figure #4)

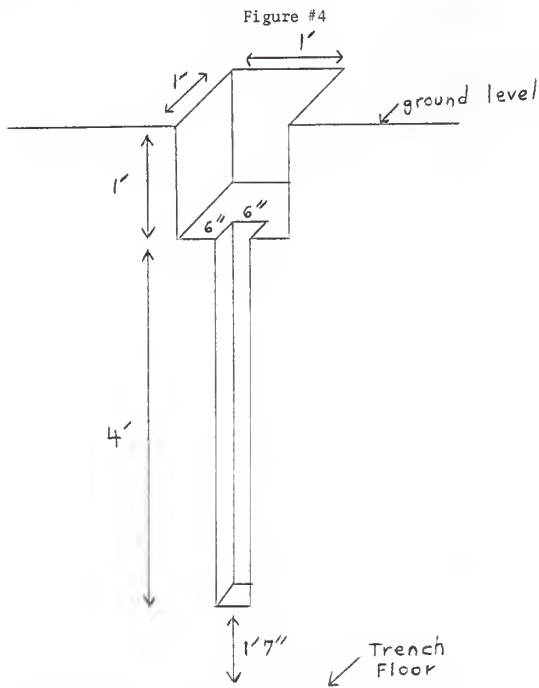

XII. Place the Lintels

The lowering of the lintels into place is a very delicate job especially for the long lintel (6') stationed at the stoking-pit end.

- 1) Lay a 2" layer of adobe (banco) in each of the 4 areas where the lintels will rest.
- 2) To lower the lintels into place first place two logs parallel to one another onto the lintel shelf on one side and slope them up to the 1' dug out area on the other side (as shown in the following diagram). Then slowly slide the lintels into place. (see figure #5)

Figure #5

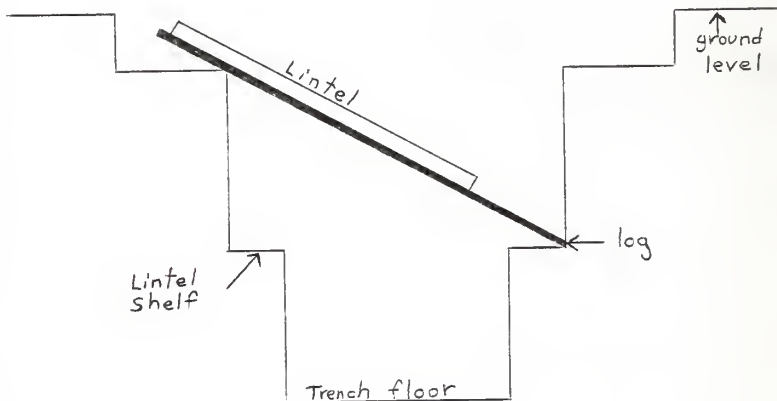

- 3) Have two men hold the lintel up while one other removes the logs underneath.
- 4) Have a third man or even a fourth man descend into the trench and help the two others holding one end of the lintel above

lower it into place.

(Lowering the chimney end lintel will not be as laborious as the stoking-pit lintel.) (see figure #6)

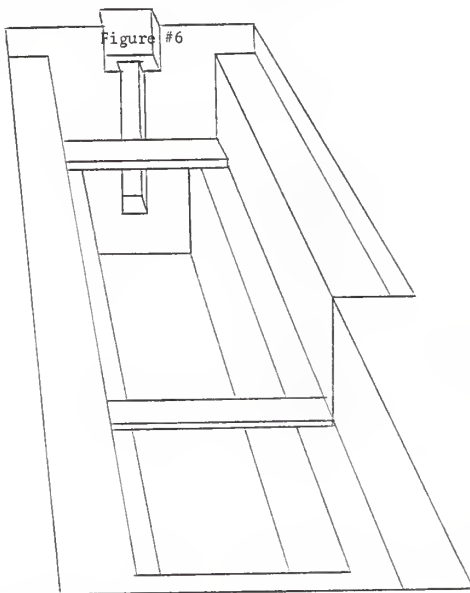

XIII. Building the Dryer Walls

- 1) Make the front and back walls over the lintels 1' thick which is exactly the same width as the lintels.
- 2) Once you build these walls up to the original 1' dug-out area, be sure to continue the entire structure as one unit! This includes building the chimney up to meet this level and also the 8" wide retaining wall around the stoking-pit. You must

have a very ample supply of adobe (banco) on hand from this point on. If this is not done then during the curing process the walls will pull apart where they have been joined. Therefore, I repeat, it is very important to continue the entire unit as one! Also be sure that the two dryer walls normal to the two lintels are 1' 6" wide from the 1' dug-out base to 10" above ground level or if the ground level is very irregular, 1' 10" from the dug-out base.

- 3) The height to which the adobe (banco) walls may be built each day depends very heavily on the "quality" of the adobe. The higher the moisture content, the less height you may attain each day you add a layer and the longer you will have to allow each layer to dry before continuing.
- 4) Once the walls reach a height of no more than 10" above ground level, the slope of the earth within the plenum chamber should be made. This is done by carving away the earth about 1" to 1.5" away from the wall base down to 1' 4" above the base of the trench at the chimney end of the trench. This should give you a slope of about 70°.
- 5) You should also make sure that the walls at this height (10" above ground level or 5' 1" from the bottom of the front lintel) are completely level because it is at this height that the logs will be placed. The two walls of the dryer normal to the two walls above the lintels will also continue at a width of 1' from this point on.

- 6) Once the top of the dryer walls are level, continue the dryer walls another 4" but all at a width of 1'. This should leave a 6" shelf on both sides of the dryer for the logs to be placed. At this 4" height above this shelf, embed a strip of chicken wire, or other type of wire mesh you have chosen, into all four walls of the dryer. The strips should be 8" wide and 8' long. Embed half (4") of the wire into the wall with the other half hanging into the drying chamber over the log shelves. Later when the logs are placed, this will allow a medium to which to anchor your drying floor.
- * 7) The retaining wall around the stoking-pit hole should not be continued above this level. In fact, 10" above ground level is sufficient height for this wall.
- 8) Finally finish the dryer wall by building it 1' 4" above the wire screen or 1' 8" above the log shelf. Continue to build the chimney 10 - 12" above the dryer wall to provide a better draft and minimize the possibility of smoke entering the drying grain. (see figure #7)

Figure #7

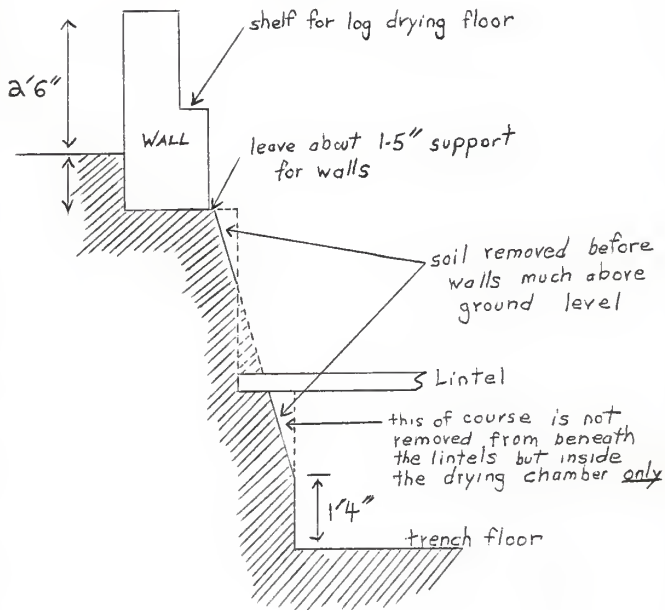

XIV. Retaining Wall Around Stoking-Pit

- * 1) As previously mentioned, this wall should be built as one unit with the dryer so that a separation between it and the main dryer will not occur during curing.
- * 2) Its main purpose is to protect the stoking-pit from water erosion during heavy rains.
- 3) It need only be 8" wide and built 10" above ground level. It surrounds the stoking-pit on three sides and joins the dryer

wall over the firebox lintel on the fourth side. (see figure #8)

Figure #8

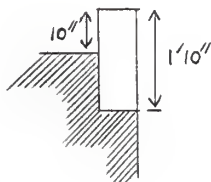

XV. Chimney

- 1) Again, the chimney should be built at the same time as the dryer to prevent separation during curing. This is even more critical here because separation from the dryer wall will mean large smoke leaks causing irregular draft.
- 2) The chimney should extend 10 - 12" above the dryer wall with its exhaust hole having no larger a diameter than 4". * At 6" above the dryer wall, place an 8" x 8" piece of chicken wire to prevent debris (such as oranges) from being thrown down the chimney by children. A good thickness (6") for the chimney wall will aid in containing the smoke and will make it easier to patch stress cracks during curing if they should occur.

XVI. Stoking Pit Stairs

This part is not so important and may be done according to the constructor's taste, but the following may be used as a guideline.

- 1) The stairs should be cut away from the wide section of earth remaining on the left side of the stoking-pit facing the chimney end of the dryer.
- 2) Cut them 1' x 1' and 1' 8" making 7 steps down into the pit with the final step being 11" high (thus giving a total height of 6' 11" to the staircase.
- 3) Do not make the staircase wider than 1' 8" so as not to undermine the earth supporting the retaining wall adjacent to the stairs. (see figure #9)

XVII. Assemblage and Placement of Firebox Barrels

- 1) Cut out both ends from two 55 gallon oil drums.
- 2) Cut out one end completely from a third barrel but leave its other end intact. At this untouched end, cut a small square hole 8" x 12" nearest the rim thereby leaving a neat chimney hole. This end with the hole on the upper side will be placed under the chimney lintel. This hole will permit smoke to exit by way of the smoke trench.
- 3) Four holes should be punched evenly around the rim of each barrel level to the holes punched in the other barrels so that when they are joined to one another, they will match perfectly making a complete 3-barrel flue.
- 4) Join two of the barrels together through the punched holes with tying wire (the chimney end barrel and one other). Do not join the firing-barrel until the two other barrels are placed in the trench to avoid great difficulty in maneuvering the barrels under the two lintels. Only after placing the

first two tied barrels in their proper place in the trench are you to then tie-in the firing barrel under the stoking-pit lintel.

Figure #9

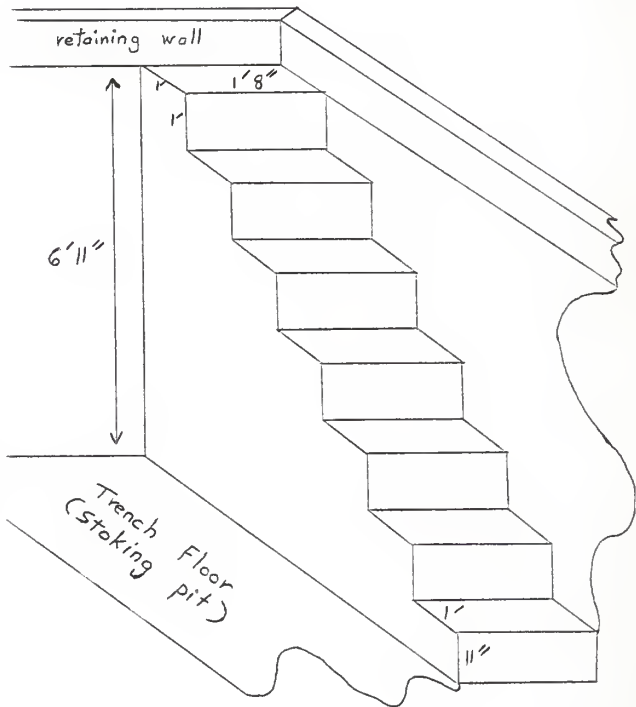

- 5) After attaching the third barrel, look through the aligned barrels to see if the chimney hole is facing up!
- 6) Remember, the last two barrels towards the chimney should have a 4" brick underneath them to allow air circulation beneath them and prevent rusting. The front fire barrel should have 2-4" bricks beneath it to give it an 8" height above the floor. This is because of the planned slope beneath this barrel that will give it maximum air circulation. Also try to slope the entire 3-barrel flue just enough so that the smoke will easily roll back towards the chimney. (see figure #10)

Figure #10

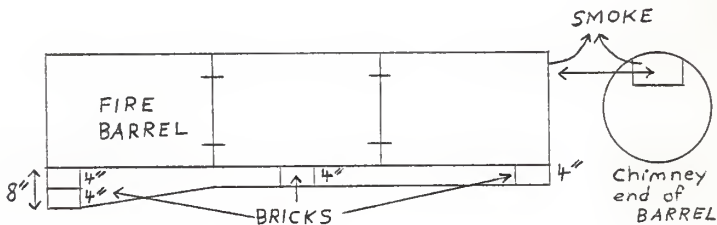

- 7) Seal the joints where the barrels are joined by placing a strip of screening (no wider than 6") completely around them with a mortar plaster (1 part Portland cement to 8 parts sand) or with a good quality adobe (banco) on the inside of the screen against the barrel joints. Paper from

the empty cement sacks should be weaved against the outside of the screen so as to assure that the mortar will hold against the joints while curing. This will also assure that the wire screening will embed itself into the mortar or clay thereby acting as a sort of strengthening armature.

- 8) Finally align the barrels one last time making sure that:
 - a) they set well on the bricks,
 - b) they slope upwards lightly towards the chimney,
 - c) the chimney cut-out is facing upwards towards the chimney lintel giving free passage into the smoke-trench.
- 9) Seal the ends of the barrels under the lintels with banco (adobe). At the chimney end, make sure that the barrel is completely sealed all the way around its circumference and flush with the lintel. This should prevent any smoke from backflowing into the plenum chamber.

Under the front lintel, completely seal only the upper half of the barrel leaving the bottom half open for air circulation. If you use a good quality adobe then no supports will be needed. Simply hand-ramming the adobe will make it hold sufficiently on its own during curing. For best results have someone inside the plenum chamber working on this seal at the same time you have someone working in the stoking-pit. This will prevent the person hand-ramming the adobe in the pit from pushing adobe clear into the plenum chamber. The adobe also should be rammed flush with the edge of the

lintel inside the plenum chamber and flush with the barrel edge in the pit.

- *10) Always test the seals by lighting a smoky fire in the fire barrel to see if there are any leaks in the plenum chamber. If leaks occur then seal them immediately! Make sure the fire is only smoky and not hot! You do not want to dry the mortar (or clay) seals around the barrel joints too quickly or they will crack! You want them to cure as slowly as possible. Do not place the logs for the drying floor until you have completed this step!

XVIII. Placing the Drying Floor

This is the very last step before finishing the dryer. Make sure all work dealing with the trench, plenum chamber and fire barrels is completed before placing the logs for the drying floor.

- 1) Use 10 logs of solid wood and fairly heat resistant. In Africa the most applicable in this case is teak wood. The logs ideally should be 4" x 4" x 8' but if these logs are obtained near a village then most likely they will have a diameter of 4" at the base then taper to a 2-3" diameter at the tip. Since this case is the most probable then one should alternate the logs in the dryer so that you have a sequence along one shelf starting with a 4" base then continuing; 2" tip, 4" base, 2" tip, etc. etc.
- 2) Space the logs evenly across the shelf under the screening which is embedded into the wall on all four sides. Resting

these logs into their places instead of "mortaring" them in place will make them easier to replace if they weaken. If they are round logs then you can place adobe on each side of their ends to prevent them from rolling.

- 3) Finally stretch the screening across the logs and tie it into the screening embedded into the walls above the logs. This will make one continuous drying floor good for drying ear corn. All sections should overlap by 2" so that they can all be easily attached by weaving tying wire between all overlapped sections.

This is, of course, only one type of drying floor that can be used. Weaved thatched palm branches also make an excellent drying floor but it also has to be replaced more often (the cost factor though make it very worthwhile). These woven mats should be attached to the embedded screening in the wall in much the same manner that the chicken wire would be attached.

If shelled corn is to be dried then perforated tin-roofing is an excellent material. Simply flatten the corrugations out with a hammer and then perforate it with holes using a hammer and nail. This makes a very durable and long lasting floor. It also makes turning the grain during drying much easier.

FRONT VIEW

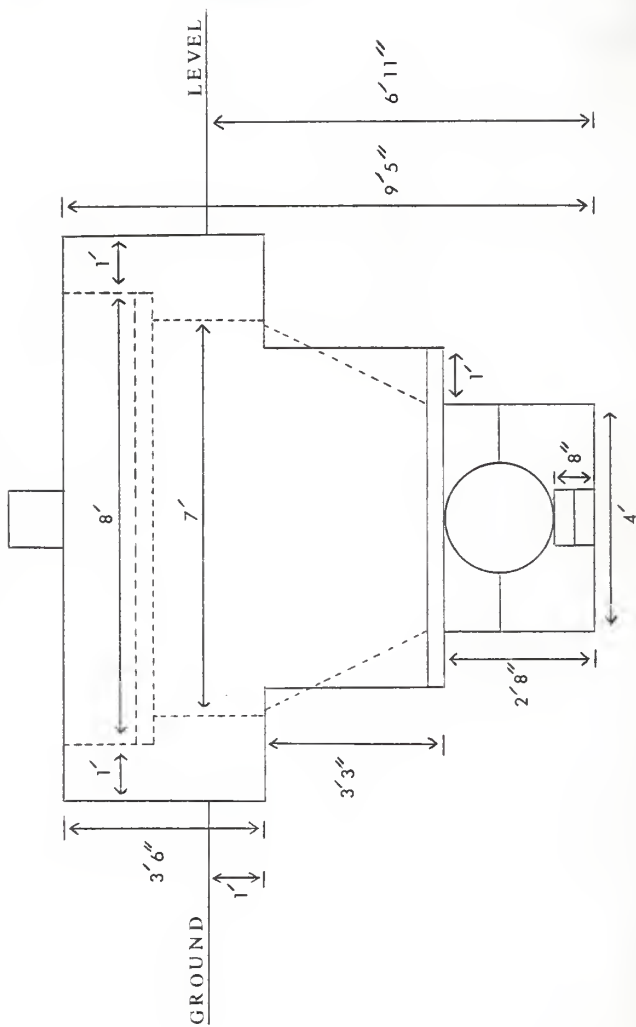

SIDE VIEW

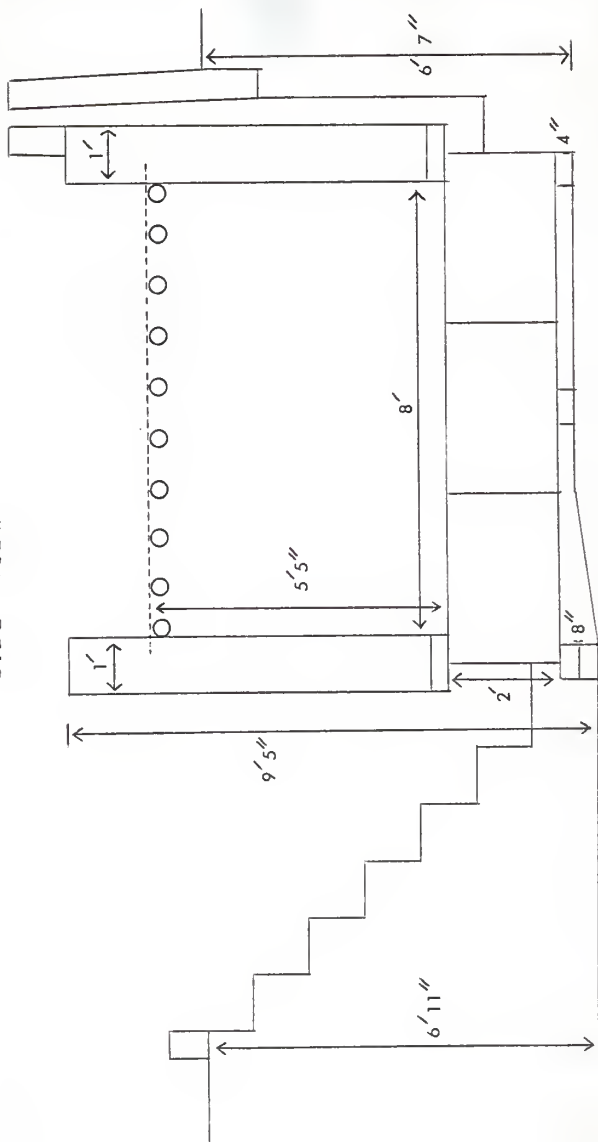

TOP VIEW

98

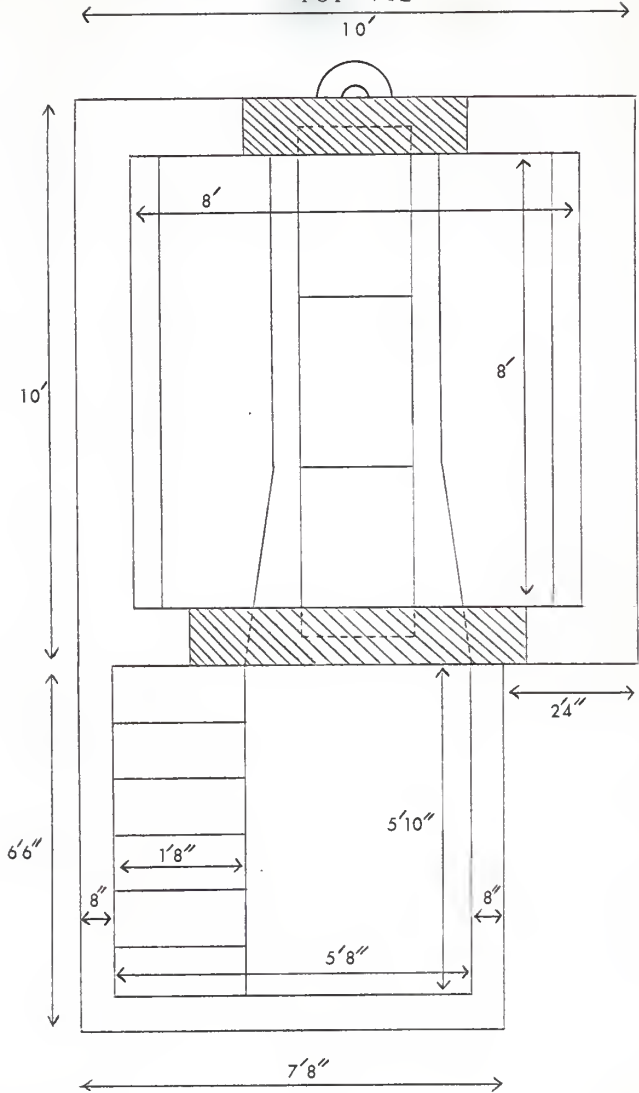

DEVELOPMENT OF A NATURAL CONVECTION DRYER
FOR ON-FARM USE IN DEVELOPING COUNTRIES

by

FRANCIS NOEL BOLDUC

B. S., University of Vermont, 1973

AN ABSTRACT OF A MASTER'S THESIS

submitted in partial fulfillment of the

requirements for the degree

MASTER OF SCIENCE

Department of Grain Science and Industry

KANSAS STATE UNIVERSITY
Manhattan, Kansas

1978

1

The objective of this study is to develop a more efficient convection dryer which can be adopted for on-farm use in developing countries. The modifications introduced were meant to improve the Peace Corps-Benin-Brook type dryer by increasing the drying performance without increasing its low-cost factor.

The dryers were built of adobe made from Kaolinite clay. A flue and stoking pit trench were first dug as a foundation before the adobe walls were mounted. The flue for both dryers consists of 3 - 55 gallon oil drums laid end to end in the flue trench. The drying floors consist of 10 - 4"x4"x8' cedar logs laid horizontally between the adobe walls to support the perforated metal floor. The grain median dried was maize and the fuel used was wood. The stoking pit is used for storing wood and for fueling the fire-barrel.

The modifications made on the unmodified dryer were:

- 1) the floor height was increased from 1m to 2m above the flue
- 2) the air inlet was increased from 3.65 ft² to 8.65 ft²
- 3) the flue trench was wedged from the air inlet back to the chimney end.

There are four main factors that were tested on the drying performance of the two dryers in terms of drying rate, dryer (thermal) efficiency, fuel efficiency and grain quality (moisture gradient). The four main factors are:

- a) initial moisture contents of 20% and 25% (wet basis)
- b) grain depths of 4" and 6"
- c) effect of turning the grain every 2 and 4 hours with no turning used as a control

d) air intakes of 1/2 and full size.

The grain used for the drying test was freshly harvested shelled yellow dent corn obtained in the fall of 1977.

In summary, this study showed that the effect of turning the grain and the air inlet size was more pronounced than the effect of the initial moisture content and the grain depth on the overall drying performance of both dryers. A more equal temperature distribution with a higher airflow rate resulted from an increase in the drying floor height, a wedged flue trench and with an enlarged air inlet in the modified dryer. Consequently, a very considerable improvement in the drying performance of the modified dryer over the unmodified model resulted. The overall performance of the modified dryer over the unmodified dryer was increased by 100% in terms of drying rate, dryer efficiency, fuel efficiency and grain quality (as to moisture gradient).

The recommendations are that the grain depth be kept at 4" (10 cm) for shelled maize, that the grain be turned every 4 hours, that a full air inlet be used and that the initial moisture content be 25% (wet basis) if possible. The fuel efficiency of either dryer may be further increased by as much as 50% by continuously drying from one drying batch to another.

The drying of maize in both dryers can be described by the following equation:

$$\frac{M - M_e}{M_o - M_e} = A - Bx$$

This investigation not only shows subsistent farmers in developing countries how to build a more efficient dryer without increasing its costs over his present dryer (Peace Corps-Benin-Brook type dryer) but also how to operate it more effectively in order to obtain better quality grain for storing or processing.