

AUTOMATON OF LIVESTOCK
HANDLING AND FEEDING

by

LEO THEODORE WENDLING, JR.

B. S., Kansas State College of Agriculture and Applied Science, 1947

A THESIS

submitted in partial fulfillment of the

requirements for the degree

MASTER OF SCIENCE

Department of Agricultural Engineering

KANSAS STATE COLLEGE
OF AGRICULTURE AND APPLIED SCIENCE

1956

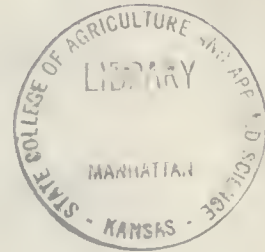

LD
- 2668
T4
1956
W47
c.2
Document

TABLE OF CONTENTS

INTRODUCTION 1

SURVEY OF LITERATURE 3

 Literature on Basic Principles of Work Simplification 4

 Literature on Livestock Working Corrals and Equipment 5

 Literature on Livestock Feeding Systems and Equipment 7

 Literature on Feed Handling Methods and Equipment 9

PRINCIPLES OF LIVESTOCK AUTOMATON 11

LIVESTOCK WORKING CORRALS 13

 Working Corral Location 15

 Topography 15

 Access 15

 Utility 16

 Protection 16

 Working Corral Design and Construction 16

 Holding Pens 17

 Crowding Pens 25

 Working Chutes 31

 Loading Chutes 43

 Squeeze Chutes 45

 Spray Pens 54

 Scales 54

 Gates 55

 Working Corral Layout 56

 Summary 73

 Holding Pen 73

Crowding Pen	73
Working Chute	73
Loading Chute	74
Squeeze Chute or Head Gate	74
Scales	74
LIVESTOCK FEEDING LOTS AND EQUIPMENT	74
Feeding Lots	75
Feeding Bunks	77
The Box Feeder	77
Feeding Racks	85
Fence Line Feeders	94
Self-Feeders	99
Self-feeders for Grain	104
Self-feeders for Hay	104
Self-feeders for Silage	113
Methods of Distributing Feed	120
Wheeled Cart and Track Carriers	121
Wagon	121
Self-unloading Wagon	122
Power Scoop Feeding	122
Bunk Line Conveyors	127
FEED HANDLING	127
Hopper-Bottom Bins	136
Belt Conveyors	137
Chain Conveyors	140
Screw Conveyors	143

Bucket Elevators	145
Pneumatic Conveyors	147
CONCLUSIONS AND SUMMARY	150
ACKNOWLEDGMENT	155
LITERATURE CITED	156
APPENDIX	158

INTRODUCTION

One of the problems facing the American livestock producer is automaton of livestock handling and feeding. Competition in agriculture is demanding each operator manage and use all available resources efficiently to survive and prosper. Automaton as used in this study may be defined as the technique of applying technological information to livestock production labor efficiency. Such applications in livestock handling and feeding have failed to keep pace with current developments. Progress made in this field has been slower than in other phases of agriculture. Livestockmen are generally aware of this condition. They are also familiar with the increasing cost of farm labor and its decreasing supply. The need for improved labor management is recognized and an effort is being made to do something about the situation. The question is how to do the job? What is the best and most economical solution to the individual producers problem? To date there has been no one source of data to provide the answer to this question. Available published information on the subject tends to be specialized. Most of the data covers either one method of doing a specific feeding or handling task on a particular farm or provides technical information on some specific job related to the subject. It is very difficult for the livestockman to assemble and apply such scattered information.

The study presents in a consolidated form an accumulation of facts both technical and empirical on the techniques of applying automaton to cattle production labor efficiency problems. The scope of the information includes: layout, design, and construction data on the structures, equipment, and machines used for cattle handling and feeding.

The object of the study is to assemble in one source enough information to aid any livestockman with the installation of an efficient effective livestock handling and feeding system. This was accomplished by summarizing the available published information, studying and analyzing numerous practical installations using efficient feeding and handling systems, and applying the logic of established work simplification principles to these data. It is believed the information can serve livestockmen as a guide on the subject. Such a guide would be invaluable to a cattleman when planning and developing new or improved facilities.

The wide range of variables encountered in the cattle production business makes it necessary to keep the information somewhat general. Facts and basic principles or fundamentals are presented on the following topics:

1. Basic principles of automaton in livestock handling and feeding.
2. Recommendations for functional design and layout of handling equipment.
3. Recommendations for the design and layout of feeding lots and equipment.
4. Basic characteristics and information on the use of feed conveying machines.

In each case an objective analysis of alternative methods and equipment available to do the various tasks is considered. These topics include the major fields of labor use in livestock handling and feeding.

SURVEY OF LITERATURE

The following is a survey of literature on the subject Automaton of Livestock Handling and Feeding. Only those materials applying to cattle production are included. The literature reviewed was of three general types; periodical news items, authentic publications, and technical data. Most issues of the leading agricultural newspapers or magazines include some item on at least one phase of automating livestock handling or feeding. These sources of information are normally non-technical illustrated stories of some livestockmen's way of doing a specific job. They stimulate thinking and present ideas but are generally inadequate within themselves to permit active application by others. The frequency of such items does, however, indicate interest in the problem and shows a need for more complete information. The authentic publications referred to are governmental and state bulletins, circulars, or leaflets. Literature of this type generally presents a recommended solution to a specific problem. The information is based on scientific research or practical experience in the field. The technical data includes parts of some government or state publications as well as books and research reports. Much of this data is a presentation of research findings. This information provides the fundamentals upon which future developments are to be made.

Since effective automaton of livestock handling and feeding involves the combination of several more or less independent operations in livestock management, it is considered appropriate to classify the information as follows:

1. Basic principles of work simplification.
2. Livestock working corrals and equipment.

3. Livestock feeding systems and equipment.

4. Feed handling methods and equipment.

These classes represent the four major areas of management under consideration in this study.

Literature on Basic Principles of Work Simplification

The written material in this field covers reports of careful studies conducted during the past few years. Vaughan and Hardin (19) define work simplification as:

--- the development and use of easier, quicker, and more economical ways of doing farm jobs. Essentially it is an application of the industrially developed techniques of scientific management and methods engineering to farm work.

Studies conducted by these same authors show the basic consumers of labor in farm work to be the movement of the hands and body without changing location, the movement of the worker from place to place, and the movement of materials and equipment. Further developments of the study resulted in the formulation of what is referred to as fundamental principles of effective work (19).

1. Have buildings and work areas close together to reduce travel.
2. Provide for circular travel to eliminate backtracking.
3. Use gravity to move feed and supplies--chutes, feed bins, self-feeders, etc.
4. Provide paths, alleys, and doorways that are sufficiently wide, level, and smooth for carts.
5. Locate tools and supplies at the place where the work is done.
6. Combine jobs and rearrange for better order.
7. Plan to complete one operation where another begins.
8. Haul maximum practical loads to reduce trips.
9. Work at reasonable speed--avoid wasting energy.

When presenting a summary on how to increase "production work per man" while doing chores French (5) suggests planning chores in advance to minimize the

number of times feeds are handled, planning an overall layout for the barnyard and fields, and studying the current methods being used to do the job. Thorough analysis of the current practices can best be accomplished by following a set procedure according to Hardin (6). He suggests the following four-step procedure of analysis.

- Step I Break down the job - Observe what you are doing.
- Step II Question every detail - Think about what you do. (why is it necessary and what is its purpose? - where and when should it be done - who should do it? - how is the "best" way to do it?)
- Step III Develop the new method - Decide on a better way. (apply the principles of effective work.)
- Step IV Apply the new method - Act on your new ideas. (improvements will not help unless they are used.)

These principles according to the literature reviewed are the tools that can be used effectively when developing efficient livestock labor management practices.

Literature on Livestock Working Corrals and Equipment

The information in this area deals with the layout, design, and construction of the various facilities and equipment needed for loading, unloading, weighing, sorting, confining, and treating cattle. The safety and ease with which these operations can be accomplished are important to the livestockman. The values to be derived from this type of equipment are many. Krewatch and Meyer (12) include the following as some of the more obvious: save labor, help prevent injury to both the animals and the owner, assist in maintaining herd health, and increase profits. These authors consider location important for successful operation. Leading factors to consider are well drained ground, convenient to pastures or buildings, and access to trucks for loading even during bad weather.

Miller and Tolman (14) present considerable information on construction requirements. The following were included as essential construction features. Crowding pens must be strong; in other words one should use heavy posts well set and spaced closely. The fence height should be five and one-half to six feet. Plank and heavy poles are suitable fencing materials. Make gates strong and free swinging and be sure they are equipped with quick sure fasteners. The inside surface of crowding areas should be smooth to prevent bruises, curved corners are also recommended. The entrance to the system should be in a corner for ease of working cattle into the corral. A "wing fence" five to ten rods long and at an angle from the entrance gate is helpful. Near level sites or arrangements where the cattle are worked up hill are desirable.

The basic requirements for a spray pen as recommended by Huber (8), have at least two pens, one for holding and one for spraying. The suggested width for the spraying alley was eight feet. Catwalks should be provided for convenience. The recommended height for catwalks is about four and one-half feet above the ground. A top rail on the fence at waist height above the walk is helpful as a support for the sprayer. An eight foot by thirty foot spraying alley will hold a carload of grown cattle according to Cuff (4).

Recommendations on the area required for working corral holding lots or crowding pens ranged from 25 square feet for each cow and calf Koch (11) to 60 or 80 square feet of space per animal Oregon State Extension Bulletin 715 (1).

The basic requirements for livestock equipment such as working chutes, loading ramps and head gates were about the same in all the literature reviewed. The major working chute recommendations were minimum length approximately 30 feet, height of fence six feet, bottom width 18 inches, top width

30 inches. Additional features which were listed as desirable include a catwalk, a weather proof floor, and nearly solid sides up at least two feet. Loading equipment should be located where it can be reached from outside the lots at any time by truck or trailer. The recommended maximum width for the chute is three feet in the clear. Either the step or ramp type floor in the loading chute is quite satisfactory provided it is not too steep (1). The side opening style of head gate is usually considered somewhat faster than the end opening gate (14).

Literature on Livestock Feeding Systems and Equipment

The information under consideration in this section includes the facilities and equipment used for cattle feeding. Layout, design and construction are the major points of concern. One of the first steps in establishing a feeding system is to determine the basic space requirements and size specifications.

The following information on this subject is taken from tables listing the most generally accepted requirements for cattle under practical management in "The Farm Book" (17). Feeding lot area was 150 to 500 square feet per head if unsurfaced and 35 to 100 square feet per head if surfaced. Wintering lot area for beef or dairy are 300 to 1000 square feet per head when unsurfaced. Hay manger length per head is 18 to 30 inches of feeding space and throat height 20 to 26 inches. The feed bunk length per head needed is 18 to 30 inches with a throat height of 24 to 30 inches. Water in the feeding or holding lot required is one square foot of open surface per 25 head for a pressure system. Shelter needed for beef is 25 to 40 square feet per head, dairy 40 to 100 square feet per head. For feed storage hay without silage, baled or chopped, allow 250 to 600 cubic feet, baled hay with silage 125 to

300 cubic feet of hay per head, one to three tons of silage. If loose hay is used double the hay space requirements. Grain storage needs vary with the program. When used one should provide a minimum of 25 to 40 bushel of storage per head. Bedding storage, baled or chopped, allow 75 to 150 cubic feet per head.

The box-type combination manger and rack was found to be the best hay feeder to reduce waste by Brennen (2). The principal reason presented for waste in hay feeders was cattle backing away from the feeder with a partial mouthful of hay and subsequent dropping of some hay under their feet. A few of the basic measurements on this hay feeder are width five to seven feet, manger depth 22 inches, vertical spacer gap width 11 inches for dehorned cattle and 29 to 34 inches for horned animals with an eight inch high stub spacer centered between the regular spacers, height of head opening 20 inches. The maximum recommended depth of filling was six inches above the top of the manger. Considerable work has been done on self-feeding chopped hay at Iowa State College, Shove, et al., (15), reported the following as essential points of design for a farm built chopped hay self-feeder.

1. A tapering structure having a smaller diameter at the top than at the bottom.
2. Construction of a cone in the center of the structure to force the hay out toward the feeding manger.
3. Use of a swinging guard for the manger which permits the cattle to reach well into the structure.
4. Formation of an unlined air duct in the center of the structure.
5. Formation of "cleavage planes" in the hay to allow it to spread out over the cone.

Self-feeding silage from a trench, stack, or bunker silo can be done with about a tenth of the labor ordinarily required according to VanArsdall and Cleaver (18). They list as important factors in this method of silage feeding a silo near the feed lot with a paved floor and a stable wall equipped

with a feeding fence across one end. The space requirement given was three to six inches per animal.

Literature on Feed Handling Methods and Equipment

This section includes information on various aspects of the machines used to transport, load, or unload livestock feeds. Henderson and Perry (7) classify handling devices as follows:

1. Belt conveyors
2. Chain conveyors
3. Screw conveyors
4. Bucket elevators
5. Pneumatic conveyors
6. Gravity conveyors
7. Cranes
8. Lifts and carrying trucks and carts

All of these devices may be used in livestock feed handling. Some of the basic characteristics given for the more common feed handling machines were:

Belt Conveyors. Belt conveyors have a high mechanical efficiency. They induce very little or no damage to the product being transported. They have a high carrying capacity, are adapted to long distance movement, and give long service. The major disadvantages of belt conveyors are high initial cost, low limit for the angle of elevation, and they require careful engineering to insure satisfactory operation.

Chain Conveyors. Chain conveyors are easy to build, inexpensive, and do not require special skill for design. They are very versatile to different agricultural uses. The major objections to chain conveyors are low mechanical efficiency, noisy, and relatively slow. The three general types of chain conveyors are trolly, scraper, and apron.

Screw Conveyors. The auger or screw conveyors are well adapted to use in agriculture for handling finely ground products. They are simple,

relatively inexpensive, dust tight, easy to move, and reasonably accurate in rate of delivery. The chief disadvantages of screw conveyors are a high power requirement and a limit to the length for single sections.

Bucket Elevators. The bucket elevators are what might be considered a modified version of either the belt or chain conveyor. They are well adapted for the vertical movement of feeds. Bucket elevators are very efficient when properly designed. They are generally more expensive than the scraper conveyor.

Pneumatic Conveyors. Pneumatic conveyors or blowers are well adapted to some agricultural uses. The chief advantages for this type of conveyor are relatively low initial cost, mechanical simplicity, adaptation to changing direction in conveying path, ability to handle a wide variety of materials, and the system is self-cleaning. The main disadvantages for pneumatic conveyors are high power requirement and possible damage to some conveyed products.

Knight and Dixon (10) suggested applying the following principles when working with feed handling problems.

1. Don't move it! Or move it as little as possible. Shorten distances. Let animals self-feed.
2. Handle larger amounts! Make every trip count. Eliminate small batches.
3. Make the flow continuous! Use machines to move materials automatically.
4. Condense it! Reduce bulk and weight of materials. Change their shape for easy handling.

Feed handling is a different problem for each livestock producer.

Swegle (16) suggested the operator look at the following points when deciding how much to invest and how to make materials-handling equipment pay off. How many bushels or animals are handled? Is the current supply of available labor adequate? What are the age and health conditions of the operator? Will the time saved permit the operator to do a better job with animals or crops? Will the time saved permit increasing the size of operation either livestock or

farm acres, or enable the operator to eliminate hired help?

PRINCIPLES OF LIVESTOCK AUTOMATON

The automaton of livestock handling and feeding has been defined as the technique of applying technological information to livestock production labor efficiency. This section presents a condensed version of the principles involved in its application. The information is based on data from numerous work simplification studies and is justified, however, since work simplification is defined by Vaughn and Hardin (19) as;

--- the development and use of easier, quicker, and more economical ways of doing farm jobs. Essentially it is an application in industrially developed techniques of scientific management and methods engineering to farm work.

From these two definitions it is obvious the two terms are synonymous in so far as livestock production is concerned. The material in this section provides the basis for a systematic attack to the problem of labor efficiency in a livestock program.

The starting point toward a more efficient work schedule is a complete analysis of present methods and equipment. The following is the four step procedure for making an objective analysis as presented by Hardin (6).

Step I Break down the job --- Observe what you are doing.

Step II Question every detail --- Think about what you do (why is it necessary and what is its purpose? --- where and when should it be done --- who should do it? --- how is the "best" way to do it?)

Step III Develop the new method --- Decide on a better way (apply the principles of effective work.)

Step IV Apply the new method --- Act on your new ideas. (improvements will not help unless they are used.)

When applying these four steps it should be remembered habit and custom are

two of the biggest stumbling blocks for effective labor utilization. They are no criterion for efficient work.

The major areas of labor use in livestock production are livestock handling, livestock feeding, and feed handling. Each of these topics are the subject of more detailed consideration in later sections. When developing new and more efficient methods of livestock handling or feeding periodical reference to the following principles of effective work Vaughan and Hardin (19) will help keep the thinking objective and insure sound decisions.

1. Plan to use both hands simultaneously when doing a job.
2. Relieve the hands when possible by providing holding devices.
3. Preposition materials and supplies within easy reach for convenience.
4. Carry a full load each trip to reduce the number of trips.
5. Arrange buildings and work areas close together to reduce travel.
6. Plan work travel circuits to reduce backtracking.
7. Locate tools and supplies where the work is done.
8. Combine jobs and rearrange schedules so one operation is completed where another begins.
9. Whenever possible use gravity to move feed and supplies.
10. Provide level smooth paths or alleys for travel routes.
11. Fit the equipment to the job, the farm, and the worker.
12. Make maximum use of equipment by using it in all possible ways.

The handling and processing of livestock feeds offers many livestockmen a great opportunity for automaton. The high labor cost, the decreasing labor supply, and the availability of electrical power on most farms has changed this problem quite rapidly in recent years. The principles of

efficient feed handling as listed by Knight and Dixon (10) are:

1. Don't move it! Or move it as little as possible. Shorten distances. Let animals self-feed.
2. Handle larger amounts! Make every trip count. Eliminate small batches.
3. Make flow continuous! Use machines to move materials automatically.
4. Condense it! Reduce the bulk and weight of materials. Change their shape for easy handling.

These are the tools for greater labor efficiencies in livestock handling or feeding operations on all farms. The application of these principles on any farm may require mechanization, new equipment, a better arrangement of new or existing equipment, or a combination of these items. The management in each case must determine the workable combination for the individual farm. Some additional factors to be considered along with these principles are size of operation, labor supply, available capital, and the benefits to be gained.

Economic justification for improvements which increase labor efficiency is sound only when the value of the marginal product created by the increased efficiency is equal to or greater than the cost. The marginal product in this case being the difference in labor cost per production unit and the difference in production efficiency per unit due to better handling practices or feed utilization.

LIVESTOCK WORKING CORRALS

This section of the thesis concerns the automaton of that portion of the livestock production plant commonly referred to as working corrals. The working corrals include the equipment and facilities needed and used to load,

unload, weigh, sort, confine, and treat animals. A well planned arrangement of these facilities can aid the producer in a number of ways. A few of the more important services rendered include:

1. Reduce the labor required when handling livestock.
2. Reduce injury to livestock while being handled.
3. Reduce the chance of accident and injury to the producer during handling.
4. Encourage better fly and parasite control measures.
5. Encourage better herd health by making inspection and treatment easier.
6. Encourage better management practices such as timely dehorning, vaccinating, branding, and periodical weighing.

It is quite obvious no livestock producer's facilities are complete today without working or handling corrals of some type.

The information to follow was prepared to provide a guide for the builders of such equipment. It is believed the information and illustrations can be adjusted or combined into a workable plan for any condition of terrain or management encountered by the livestockman. The recommendations are general and the designs illustrate basic principles. Corrals of similar design are serving many Kansas livestockmen quite satisfactorily at the present time. The phases of working corral planning discussed in this thesis are location, design, and construction. The judgement exercised in planning each phase is usually evident in the final product.

Working Corral Location

Location of the working corral is considered first because it is the initial step in any structural planning. The convenience of the system is dependent on the site and its location with respect to fences, roads, buildings, and other corrals or lots. The ease with which livestock can be worked into the corral depends on its location hence the importance of site selection. The more important factors to consider when selecting a working corral site include the production system, topography, access, utility, and protection.

The production system determines how, when and where the system is to be used. For example, where will the livestock be when the handling is required, in the feedyard, on pasture, adjacent to the farmstead, or away from home? It is desirable to locate working corrals near the livestock for convenience. This may mean there is a need for more than one working corral layout for some livestock programs. Working corrals can be of service in pastures as well as around barn lots.

Topography. The topography of the land is important. Relatively level sites with good drainage or with a moderate uniform slope are preferred. Cattle work better in such areas, gates are easier to operate, and it is easier to maintain a site of this type. Avoid whenever possible locations subject to periodical flooding or with poor drainage, excessive erosion, and very irregular surfaces. An available water supply may be desirable for some operations.

Access. The availability is important. That portion of the system used for loading and unloading livestock should be adjacent to a road system which

will allow movement to market or wherever desired at any time independently of the prevailing weather conditions.

Utility. Convenience and flexibility is needed. Select a location adjacent to and available from as many lots or pastures as possible. Good sites for range and pasture corrals are where several pastures meet or where natural collecting areas such as water points, mineral and grain feeders, or shelter are located. Barn yard units are best when direct access to each pen is provided and the loading area is off the farm court or road system.

Protection. Protected sites are preferred when there is a need for using the corrals during winter months. The protection may be from a windbreak, a natural bluff, or buildings. Having the corrals in a protected location encourages more use of the system. Avoid placing crowding pens, working chutes and similar equipment in areas subject to severe icing such as along the North side of a large building or heavily shaded areas.

Working Corral Design and Construction

The design and construction of a working corral can and should be adjusted to fit the producers needs and the site. Convenience, safety, simplicity, and flexibility are the keys to a successful design. It is possible to develop a very practical solution for each producer by keeping these points in mind during the planning process. As a starting point analyze the production program. Determine the number and size of animals to be handled at one time and the kind of operations to be performed. These factors provide the basis for deciding on the facilities required such as the number of pens and their size. If future expansion is anticipated it is wise to

consider this when making a decision.

The design of a working corral system is essentially a problem of arranging or organizing the different parts into a working unit. To simplify the problem the function and construction of each part are considered separately. The various parts can then be assembled for the final stage in design. The component parts of a working corral include holding pens, crowding pens, working alleys, working chutes, loading chutes, squeeze chutes or head gates, spray pens, scales, and cutting gates. The number of parts to be assembled into a unit will depend on the need and purpose of the corral.

Holding Pens. The holding pen is the confining lot into which the animals are placed or collected prior to or after working. They may be existing lots if available or they may be pens built as a specific part of the working corrals. It is generally considered desirable to provide at least two holding pens. One for holding cattle prior to working and one for holding the animals after treatment. The space required will vary quite widely depending on the size of animals, time they are to be held in the pen, and the weather conditions while in the lot. The most generally accepted space requirement varies from 20 to 40 square feet per head on calves or yearlings and 35 to 70 square feet per head for mature cows. The shape of the holding pens can be whatever the local site demands. Sharp exposed corners should be avoided in a holding pen. These pens need direct convenient access to the crowding pens, working alleys or chutes, and pastures or areas from which the cattle are assembled. A "wing fence" five to ten rods long at an angle from the entrance gate helps funnel livestock into the system Miller and Tolman (14). Placing entrance gates at a corner is also helpful in directing

livestock in or out of the holding pen. If the cattle are held in these pens for long periods or during hot weather it is wise to provide a watering point in the pen. Locate the tank where it will cause the least interference and arrange so cattle will not get in the tank when crowded.

The construction of the holding pen must be strong, however, it may be somewhat less rigid than a crowding pen fence. A five to five and one-half foot fence is recommended. Posts should be firmly set at least 30 inches deep and placed approximately two per rod or eight feet on center. A six-inch pressure treated or native hedge post is the standard fence support. Suitable substitute post materials include good three to four inch pipe set in concrete and discarded railroad ties. Use only sound fully treated ties, either pine or oak. Badly cracked or damaged ties and those just dipped are prone to rot off just below the ground line in a period of five to ten years. Purchase treated posts from a reliable source and be sure the post is fully pressure treated. The appearance of a fresh saw cut one foot from the end of the post is a simple field test for noting degree of treatment impregnation. The split or sawed post is easier to use with some fencing materials. If a split post is used a base diameter of eight to ten inches prior to splitting is required to provide equal strength and rigidity. There is a wide range of suitable fencing materials. Some of the factors to consider when making a selection are initial cost, maintenance or upkeep costs, and the frequency of use. The illustrations in Plates I, II and III show the more common fencing materials and the recommended spacings for the materials. While all of these fences may have nearly equal holding qualities when in good repair the general opinion among livestockmen seems to favor a type of

EXPLANATION OF PLATE I

Fig 1. Typical 1x6 fence board holding pen or corral fence.

Fig 2. Typical 2x6 plank holding pen or corral fence.

PLATE I

FIG. 1.

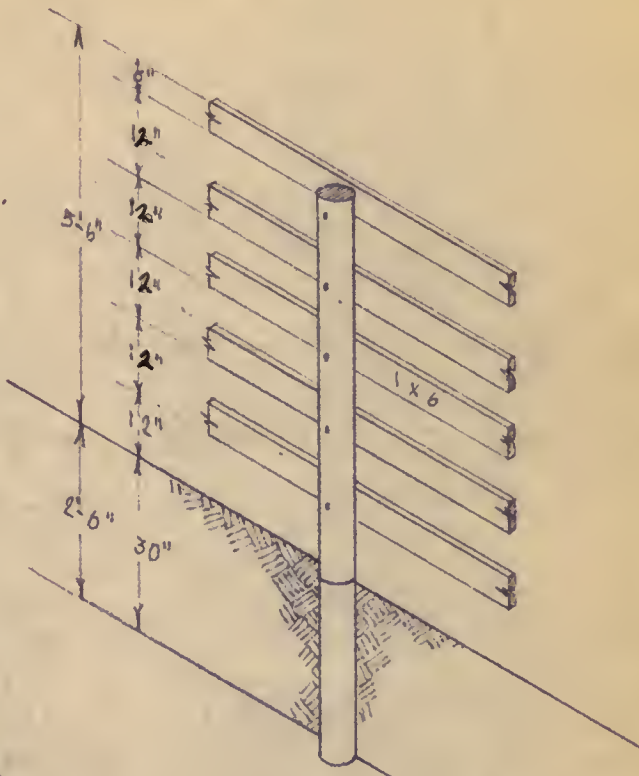
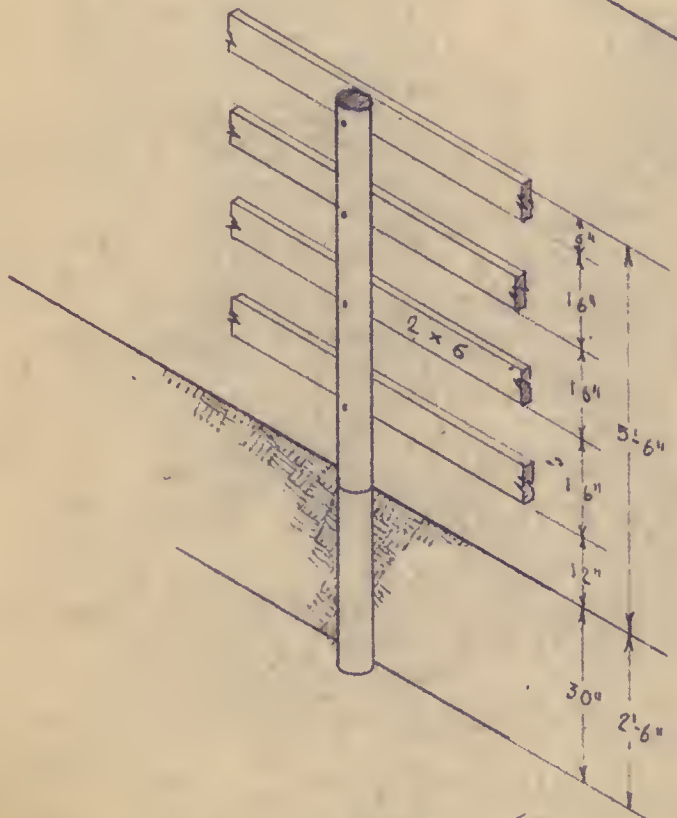

FIG. 2.



EXPLANATION OF PLATE II

Fig 1. Typical 48 inch woven wire holding pen or corral fence.

Fig 2. Typical pole or pipe holding pen or corral fence.

PLATE II

FIG. 1

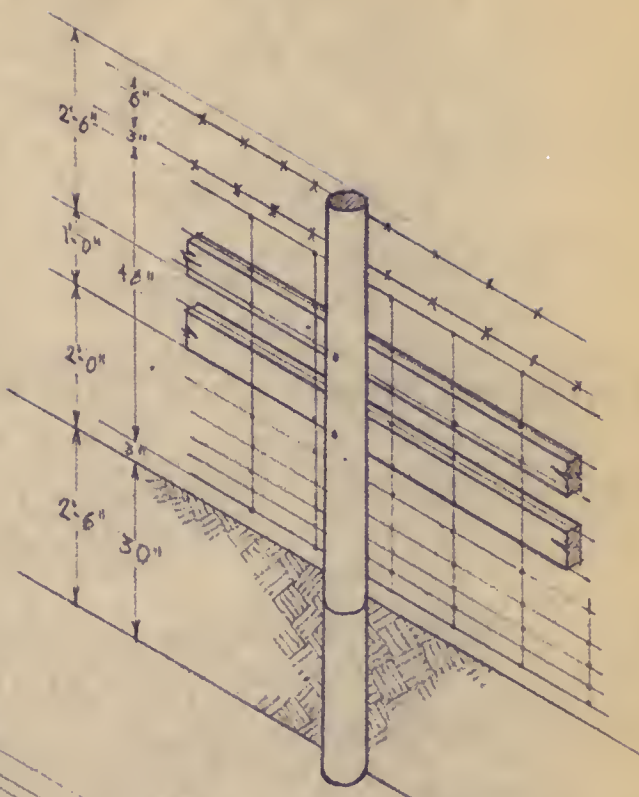
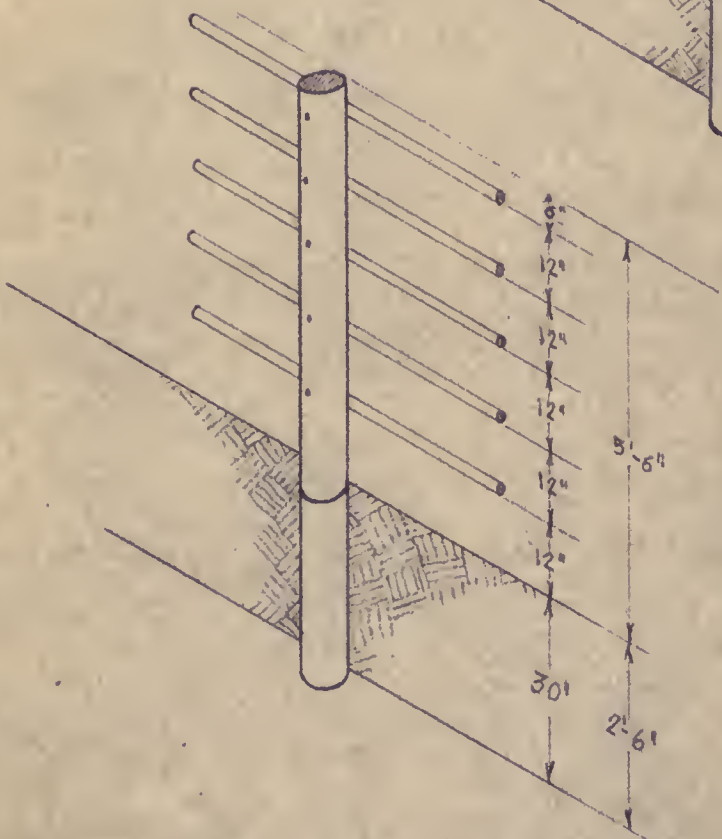

FIG. 2



EXPLANATION OF PLATE III

This is a typical holding pen or corral fence using landing mat and barbed wire.

PLATE III

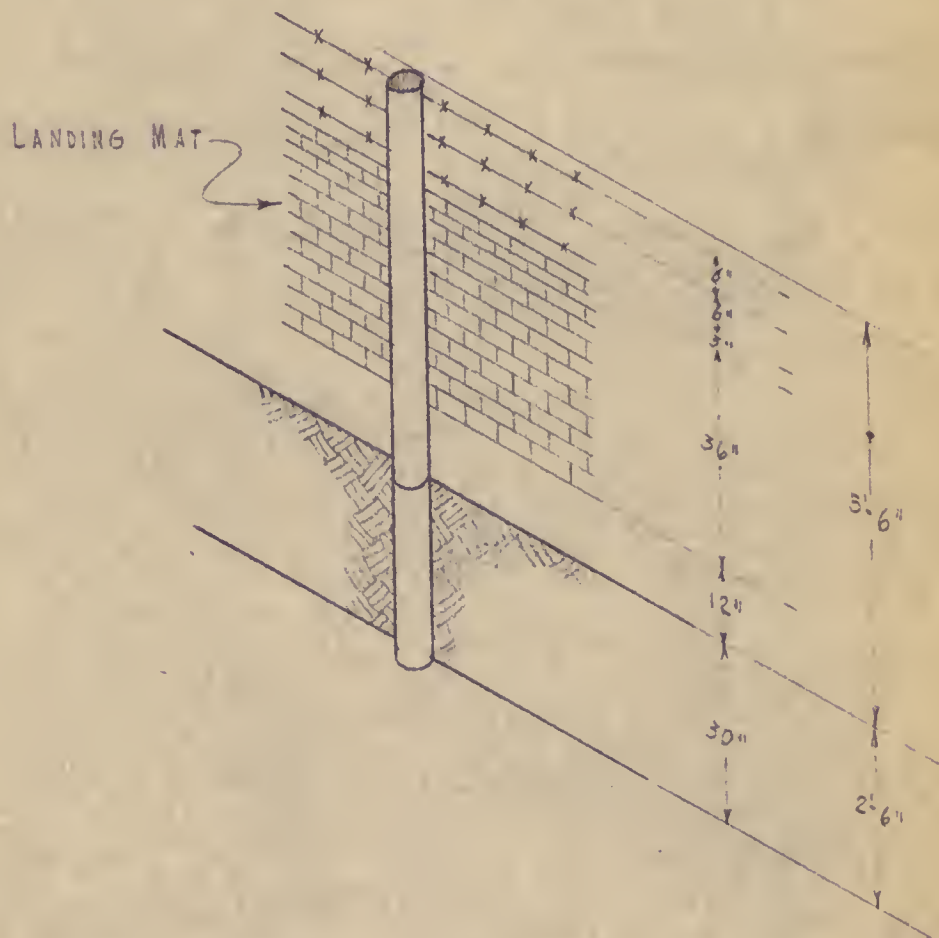

fence including pole boards or some material the cattle can see readily. This is one of the most important factors to consider when wild or flighty cattle are corraled. Stampeding into hard to see fence materials is a common problem and accounts for much of the damage to corral fences. It also results in injury to animals in some cases. Assembling the fencing materials as panels which can be fastened to the posts makes moving easy and increases the flexibility of the fence. Panel construction is especially recommended for use by tenants if they must both build and supply the fencing materials.

The methods used to secure the fencing materials to the posts varies quite widely. A few of the desirable characteristics of fasteners are good holding power, durability, ease of installation, ease of removal or replacement, minimum damage to the fencing materials, no sharp edges or projections to injure the animals, and neat appearance. Select the fastener which meets the requirements best and is most economical locally. Good fasteners are essential. The strength of a fence is determined by its weakest part. A number of accepted methods of fastening a fence to the posts is illustrated in Plates IV and V.

Crowding Pens. The crowding pen is the confining area into which the cattle are placed as a starting point for working. This pen must have direct access from the holding pens and to the loading or working chute into which the cattle will go from this pen. The major purpose of this pen is to enable closer control of the animals than the holding pen allows and provide a means of forcing the cattle to go where desired with minimum effort. In many installations this area also doubles as a sorting alley, a spray pen, and a

EXPLANATION OF PLATE IV

Fig 1. Bolt and washers used to fasten fence board or plank to posts.

Fig 2. Lag screw fastener for board or plank fences.

Fig 3. Bolt with washer and metal plate fastener used at fence board or plank junctions.

PLATE IV

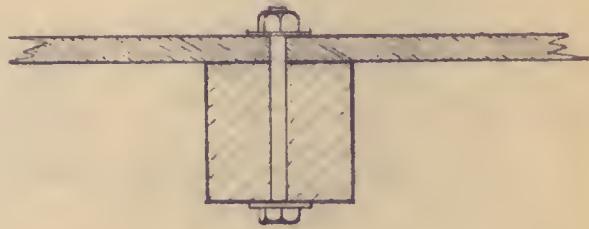

FIG. 1

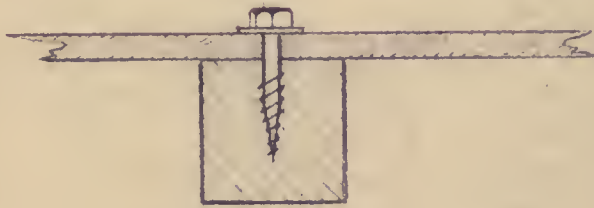

FIG. 2

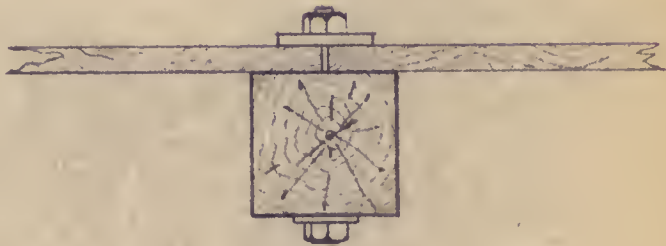

FIG. 3

EXPLANATION OF PLATE V

Fig 1. U-bolt fastener for pipe, pole, or rod fencing.

Fig 2. The use of a 40d spike in pole fencing.

Fig 3. Bolt fastener for pipe or pole fencing.

Fig 4. Metal strap pipe, pole, or rod fastener.

PLATE V

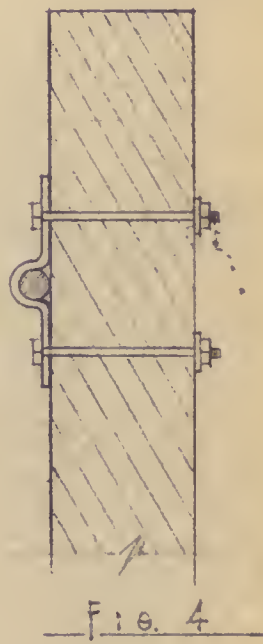
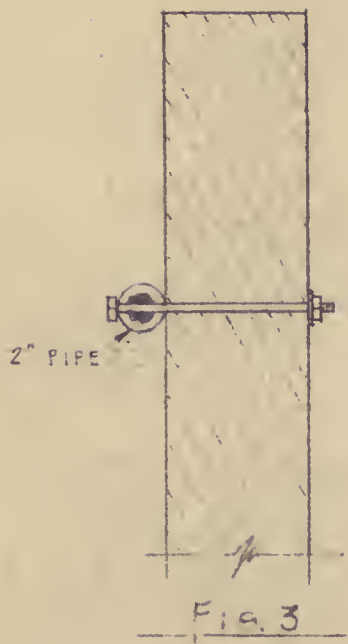
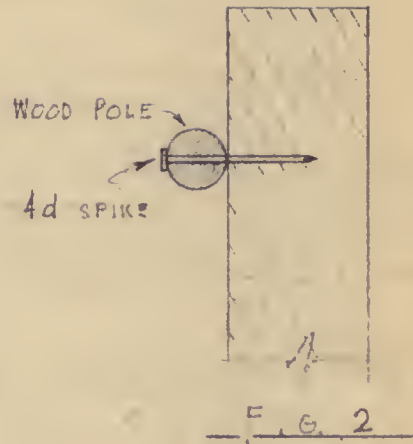
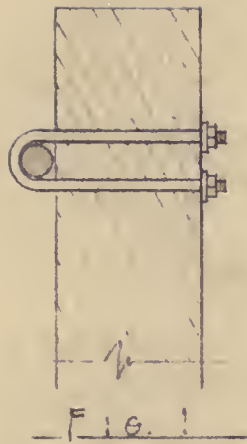

confining lot for a stray or sick animal. The minimum requirements for this area is one pen of approximately 400 square feet of floor area, enough to accomodate one large truck load (Cuff,4). When the crowding pen serves a double purpose more space is often desired. Two pens of this size or one pen twice this size which can be divided makes a good arrangement.

To be effective the crowding pen must permit close accurate control of the cattle movement. This is accomplished in most cases by the shape of the pen and the location of gates. There are three basic shapes for crowding pens in common use. They are the rectangular, triangular, and circular. A rectangular pen is sometimes called a working alley. It consists of a pen from eight to twelve feet wide and as long as needed. The pen is usually slightly tapered at one end to direct the cattle into the desired direction. This type of crowding area will normally be equipped with one or more cross gates to make control easier. The alley is preferred by many operators particularly the producer with a cow herd because it provides an excellent area for sorting or cutting large numbers of animals fast, and it is simple. This arrangement is also convenient to use as a spraying area. The circular or semi-circular crowding pens are also adapted to the large units. The major advantage to these arrangements are their effective positive crowding abilities when equipped with a crowding gate which swings across the circle from a center point. The arrangement requires more work and care in its layout and may be more difficult to erect. The triangular arrangement represents a compromise between the circular and the rectangle system. The funnel or pie shaped pen permits effective crowding especially when provided with a crowding gate. This type of pen is simpler to build than the circular

type. This arrangement is not as adaptable to other uses such as sorting or spraying. All three basic layouts for crowding pens are illustrated in Plates VI, VII, VIII.

The same principles of good construction covered in the holding pen section apply to the crowding pens, however, these pens must be built stronger. The posts need to be spaced approximately six feet on center and in the ground at least three feet. The fencing materials also must be heavier two-inch planking or its equivalent as illustrated in Plate IX. The fence should be five and one-half to six feet high. The gates should be extra strong and special care should be taken during construction to eliminate all square corners or sharp projections which might cause injury to the cattle. A well built crowding pen is essential to all working corral systems.

Working Chutes. The working chute is the lane into which the cattle are placed for treatment. The alley or lane starts at an opening off the crowding pen and normally leads to a squeeze chute or head gate which opens into a holding pen. The purpose is to aline the cattle in single file for treatment. Since this lane alines the cattle in single file it may also be used as a location for sorting or cutting gates. This arrangement for sorting has the advantage of permitting positive individual dividing. Sorting by this method is slower, however, than the group sorting possible in a working alley. The recommended length for the working chute is from 25 to 30 feet. Providing this length is very important if the chute is to be efficient and convenient to use. This length permits placing from five to seven animals in the ready line for working at one time which speeds the work up considerably.

EXPLANATION OF PLATE VI

Fig 1. Typical working corral layout with rectangular working alley, separate working chute and scale location. Adequate for up to 100 head.

Fig 2. Typical working corral layout for small unit using rectangular working alley.

PLATE VI

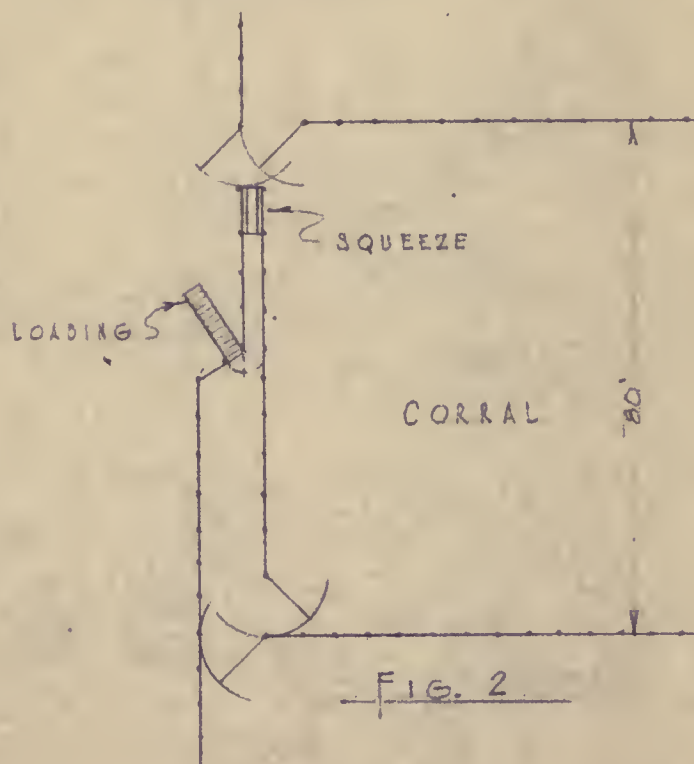
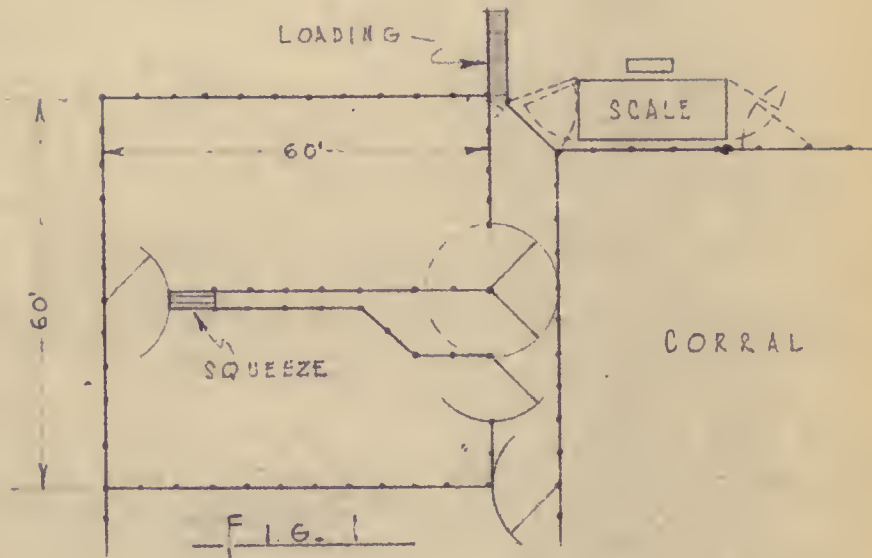

EXPLANATION OF PLATE VII

Fig 1. Working corral arrangement for small to medium sized units using triangular crowding pens.

Fig 2. Working corral layout for medium to large units with 200 head or more using triangular crowding pen.

PLATE VII

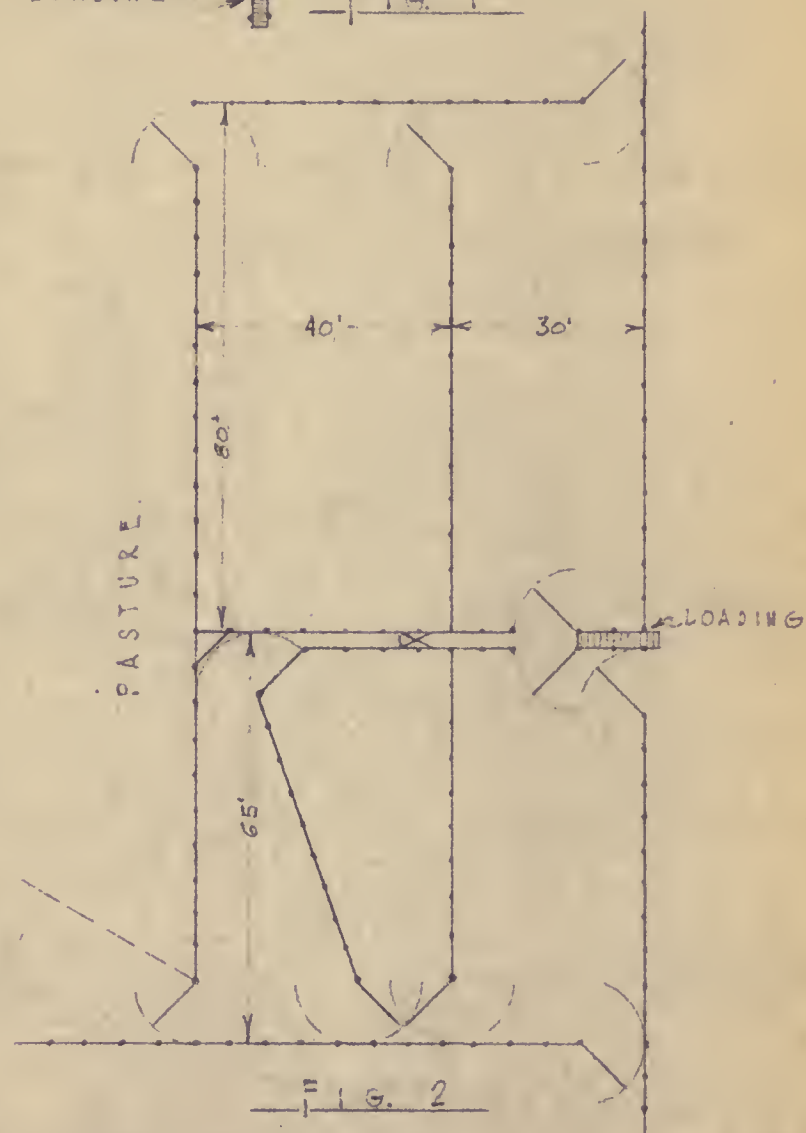
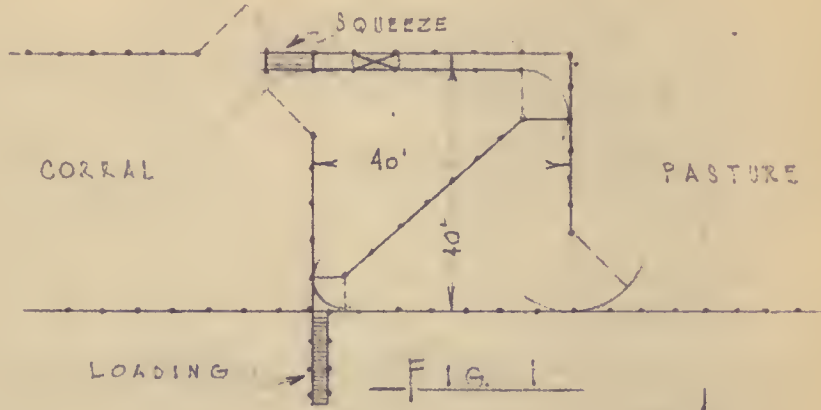

EXPLANATION OF PLATE VIII

Fig 1. Working corral arrangement for 100 to 200 head using semi-circular crowding pen with crowding gate.

Fig 2. Working corral arrangement for medium to large unit using circular crowding pen with two crowding gates.

PLATE VIII

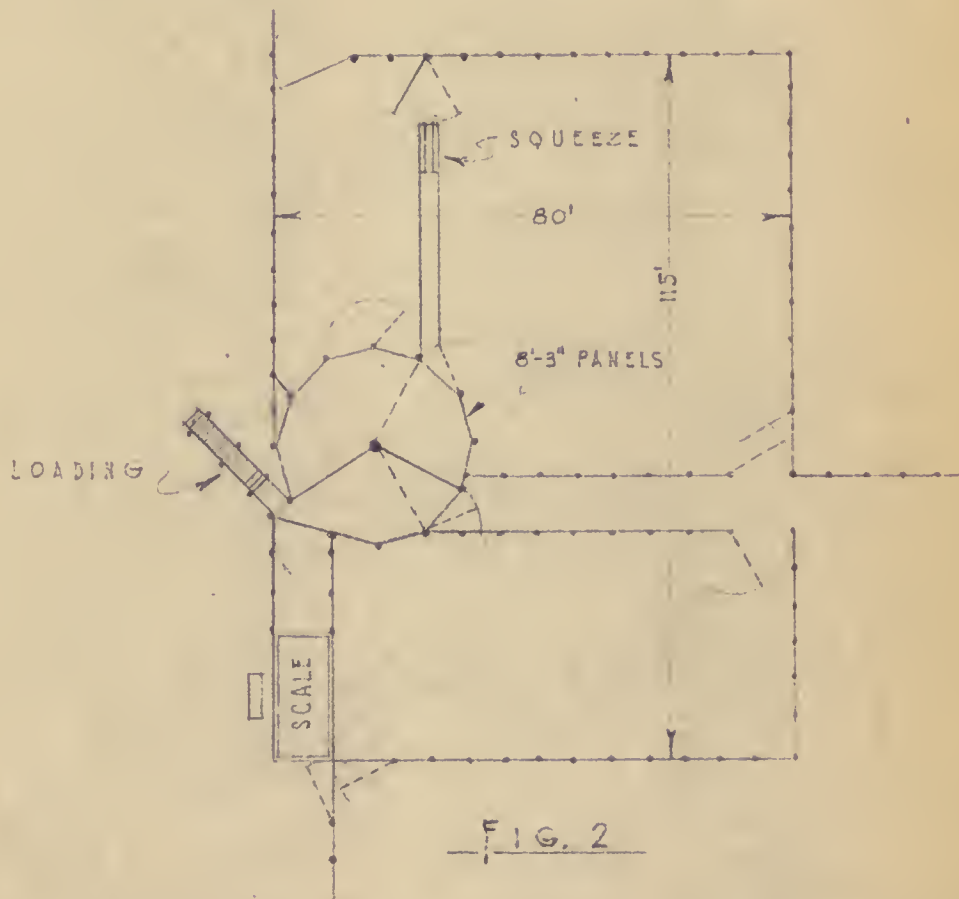
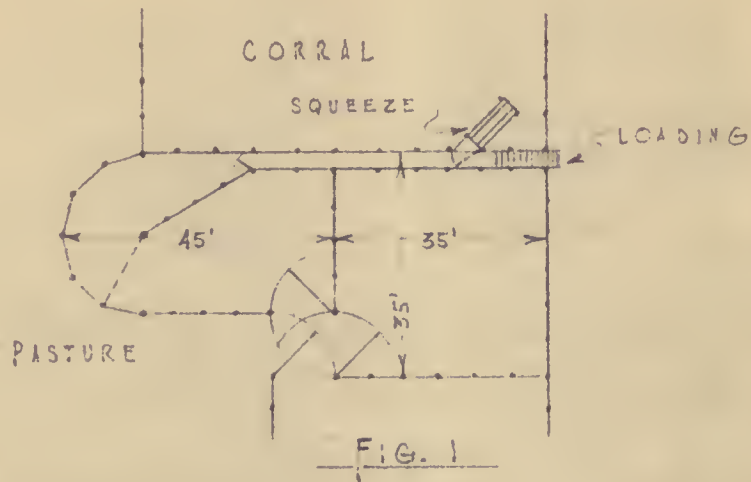

EXPLANATION PLATE IX

Fig 1. Typical 2x6 plank crowding pen fence.

Fig 2. Typical pipe or pole crowding pen fence.

Fig 3. Typical sucker rod crowding pen fence.

Fig 4. Typical 2 tier landing mat crowding pen fence.

Fig 5. Typical 1 tier landing mat and plank crowding pen fence.

PLATE IX

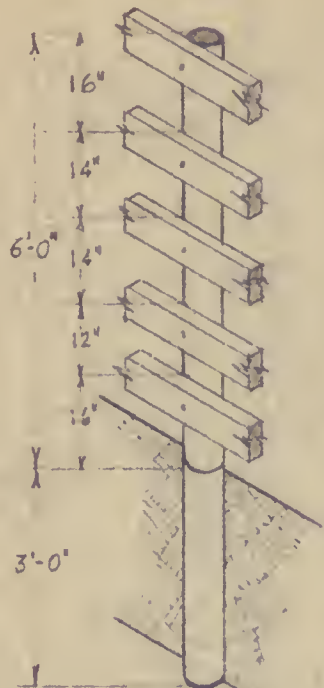

FIG. 1

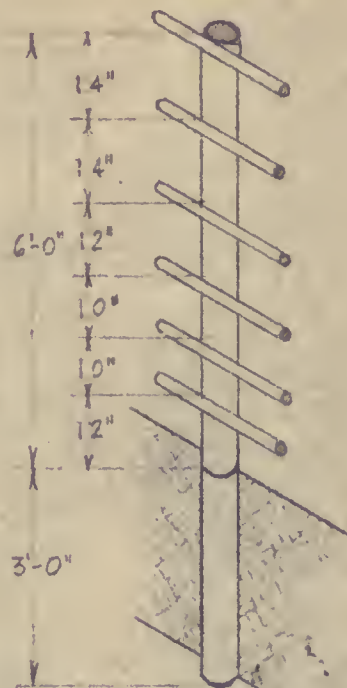

FIG. 2

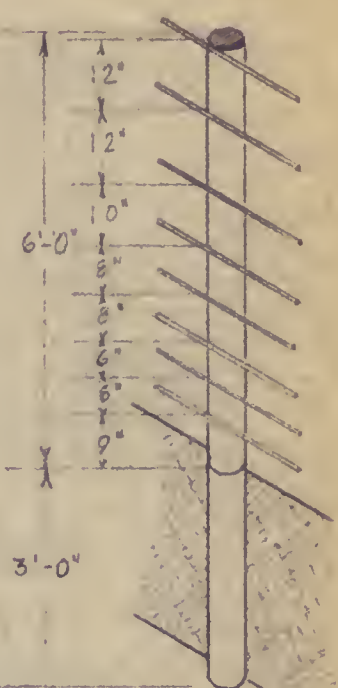

FIG. 3

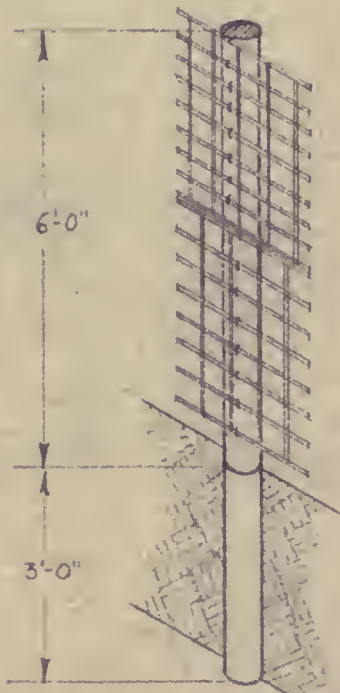

FIG. 4

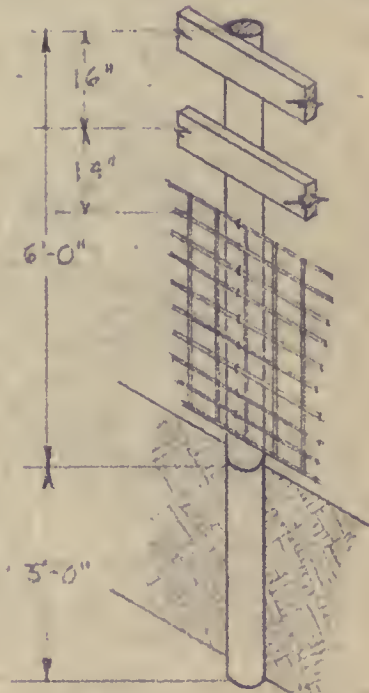

FIG. 5

Close adherence to the dimensions specified for the cross section of a chute is also quite important. The section should just fit the animal with a minimum of clearance for best results. The narrow width eliminates the problem of having more than one animal try to go through the chute at one time and discourages the cattle in the chute from trying to turn around. The generally accepted clearance required for mature cattle is 30 inches. Young cattle obviously do not need this much width in fact less width is desired. In order to make one chute serve all sizes efficiently two construction techniques are commonly used. The posts are set at an angle making the chute "V" shaped for one method and inserts are fastened to the fence to narrow the fence at the bottom for the other method. The illustrations in Plate X give the recommended measurements for both systems.

Additional construction features recommended for working chutes include: the addition of catwalk or walkway along the chute, provide solid or nearly solid sides on the fence up two feet from the floor, and provide a weather proof floor. The catwalk aids in working the cattle down the chute. The height of the catwalk should be from 24 to 36 inches. This makes the top board on the fence about waist height. The solid fencing near the ground serves two purposes; it limits the view from in the chute which aids in getting the cattle to move along better and it eliminates possibility of the cattle getting a foot or leg caught which could result in an injured animal. Suitable weather proof floors include a six to eight-inch crushed rock fill or very rough concrete. Planks are sometimes used for flooring but are generally not economical in this area. If a solid floor is omitted working cattle during wet weather can be very disagreeable and there is some danger of slipping. The working chute is one of the biggest labor savers in the working

EXPLANATION PLATE X

Fig 1. Typical working chute cross section for mature animals only.

Fig 2. Typical working chute cross section with inserts making chute narrower at bottom and suitable for large or small animals.

Fig 3. Alternate cross section of working chute for all sizes of cattle. Shows slanted posts.

PLATE X

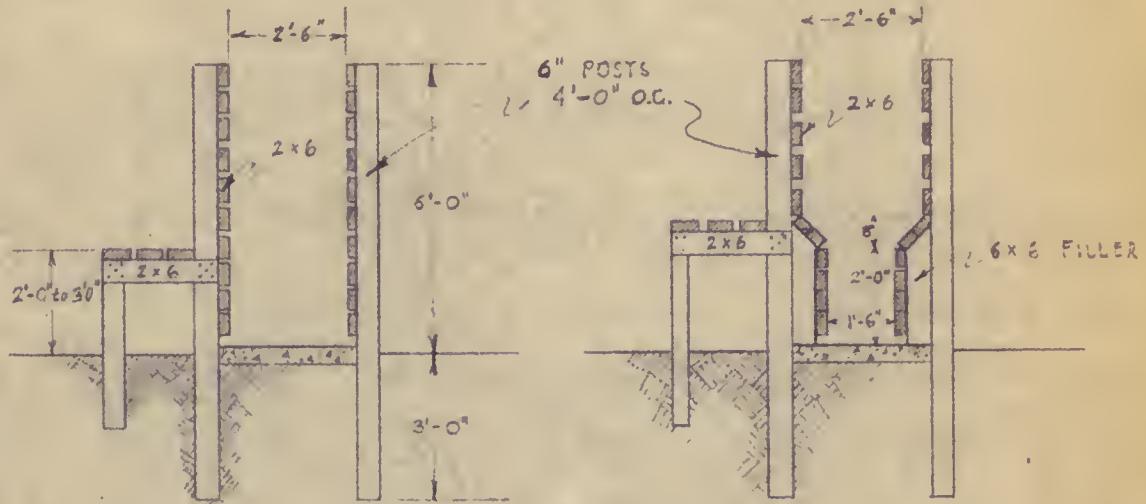

FIG. 1

FIG. 2

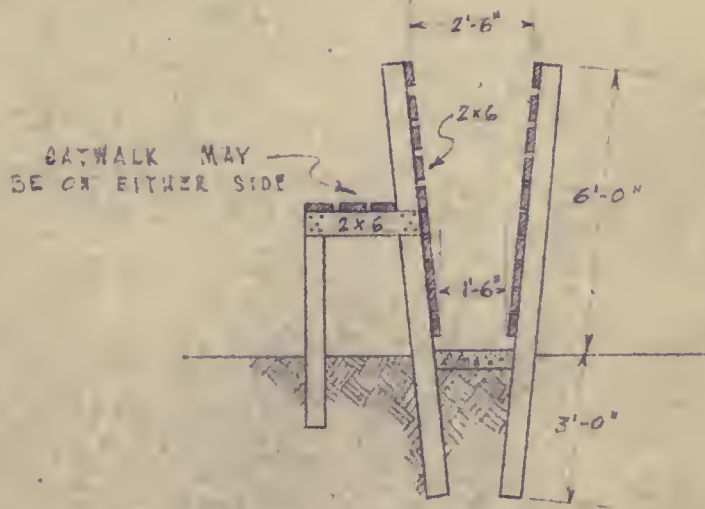

FIG. 3

corral system when properly built.

Loading Chutes. The loading chute is the equipment or device used to move the cattle vertically from the ground level to the floor level of the conveying truck, pickup, or trailer. This likewise is one part of the system which should not be omitted. Every livestockman large or small needs a loading device. Loading chutes may be classified into three groups according to their construction such as ramps, portable chutes, and permanent or non-portable chutes. Each type has advantages and disadvantages but when properly built will do a good job. The ramp is best adapted to sloping sites but they are also satisfactory for level sites with a little more construction work. The advantages for the ramp are general rigidity and the solid floor. Livestock load better over a solid floor. The inflexibility and higher construction costs on some sites are the leading disadvantages of the ramp. The floor of a ramp may be gravel and clay, crushed rock, or concrete provided it is roughed to prevent slippage when wet. The portable loading chute is best adapted to the medium or small operator who finds it necessary to load animals at more than one point. By making the chute portable one chute is adequate and thus keeps down overhead costs. Portable chutes are also desirable where the installation of a fixed chute would interfere with other work. The degree of portability can vary depending on the distance to be moved and the method of movement. Either wheels or skids can be used to make the chute portable. The disadvantages of a portable chute are the difficulty of making portable equipment as durable as desired for permanency and the tendency for portable equipment to wander from home and therefore not be available when needed. The permanent loading chute is very similar

to a ramp with the exception of the floor which is usually a suspended plank instead of the solid earth or concrete. This lowers the construction cost in most areas and permits the installation of a device which will permit changing the elevation level of the floor to match the height of the hauling machine.

Proper location of the loading chute is a point of major importance if maximum convenience and efficiency is desired. The loading chute should have direct access to the traffic or roadway system on the farm or in the pasture. This permits loading during any kind of weather which may be an important marketing consideration. The chute must also have access to either the working chute or the crowding pen for convenience of getting the cattle assembled for loading. Additional points which are desirable to consider when possible are arranging lots so the cattle are worked up hill in the pens leading to the crowding area and loading with the truck headed down hill. This makes it easier to fill the front end of the truck.

The construction of a loading chute must be rugged and durable yet the finish must be such that there are no sharp corners or edges which cause injury to the animals being loaded or unloaded. The dimensions most generally accepted for loading chutes are clearance width 30 to 36 inches, length of chute 10 to 16 feet, loading height adjustable from three to four feet, and height of sides five and one-half to six feet. Additional structural features considered desirable include solid or nearly solid sides at least two feet above the floor, cross ties overhead if used at least seven feet above the floor, and the installation of a loading platform with small access gates between the truck and the end of the loading chute proper. Many of the newer chutes are equipped with a stepped floor instead of a cleated ramp type floor.

The illustrations in Plates XI, XII, XIII and XIV give all critical dimensions and the structural details needed for construction.

Squeeze Chutes. Squeeze chutes and head gates serve the same purpose in a working corral system, that of holding the cattle securely while being treated. The proper location for this equipment is at the end of the working chute with the outlet into a holding pen. It is satisfactory to set the squeeze at an angle to the working chute if necessary provided the turn is not too sharp. An angle of 45 degrees with the horizontal being about maximum for best results. As a general rule the head gate is adequate for the smaller units where only a few head are worked at one time and the squeeze is used by the larger operations. The squeeze permits a more positive hold on the animal and therefore makes the work much easier.

Some of the features to look for on a head gate or the head holding device on a squeeze are: ease of operation, simplicity, sure fast catch, quick action, and safety. The safety feature is important to both the operator and the livestock. Care should be taken to prevent choking the animals. No one design for a head gate or squeeze chute is best for all operators, some prefer one type and some prefer another type. Select the one which will provide the most features needed in a particular case. One important point to consider when selecting a squeeze is the outlet gate location. Some chutes open to the front and some open on either one side or the other. Most cattlemen think the side opening chute is faster than the end opening chute. Be sure to place the opening so the cattle are released where they should go. It is also wise to purchase or build the needed adjustments into the chute. Some of the adjustments which are especially useful include drop bars or sections that open to permit easy access for

EXPLANATION OF PLATE XI

This is a typical cross sectional view of a permanent loading chute. The measurements can be used for any type loading chute.

PLATE XI

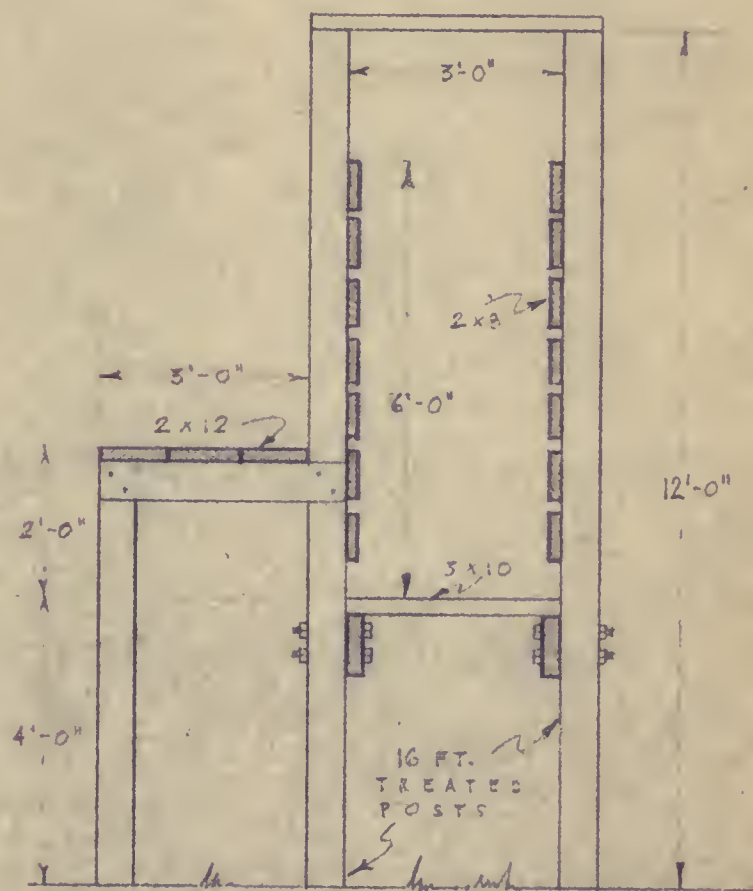

EXPLANATION OF PLATE XII

Side elevation view of typical permanent type loading chute.

PLATE XII

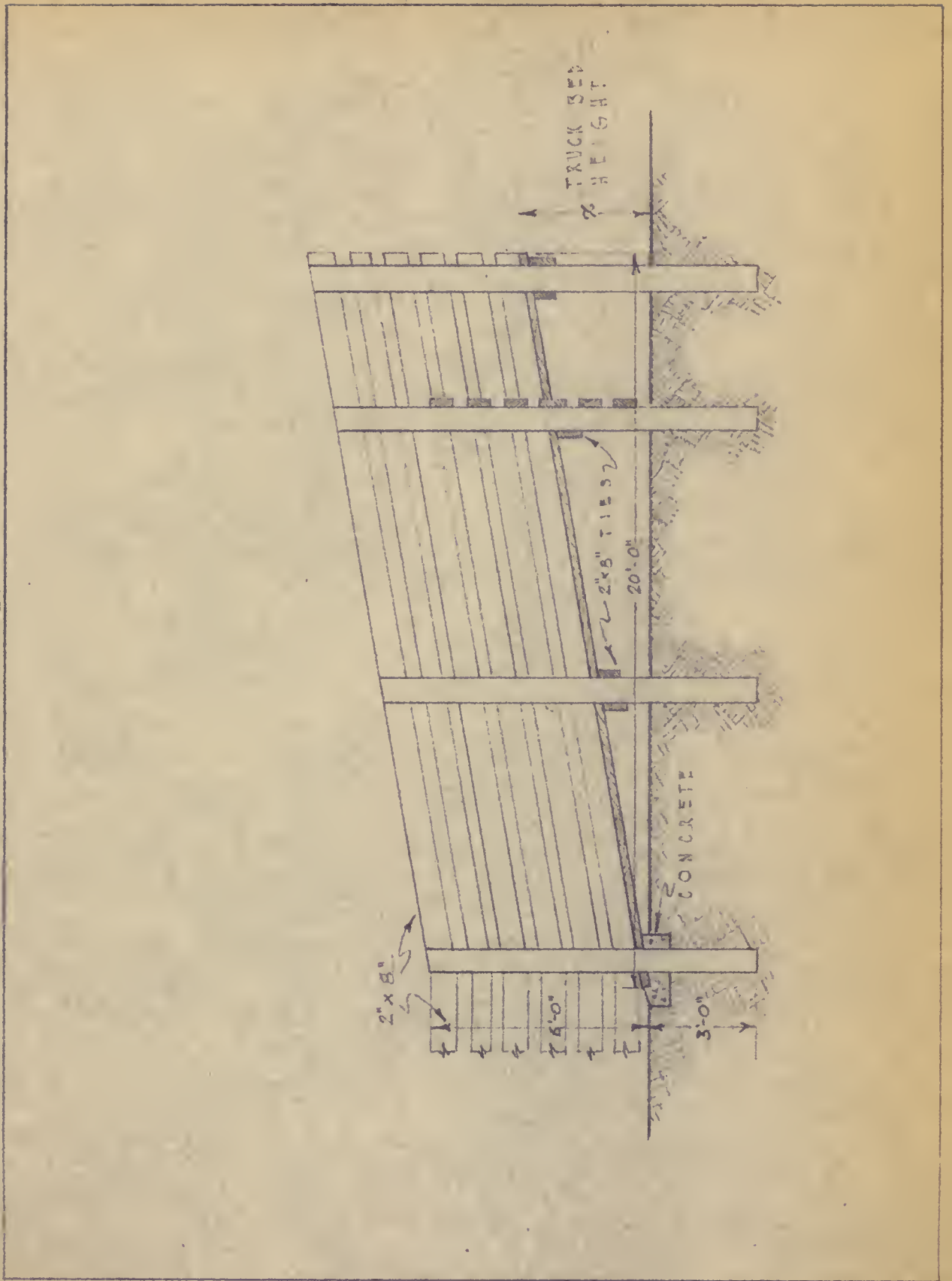

EXPLANATION OF PLATE XIII

Fig 1. Plank step floor detail for permanent loading chute.

Fig 2. Side view typical ramp type loading chute.

PLATE XIII

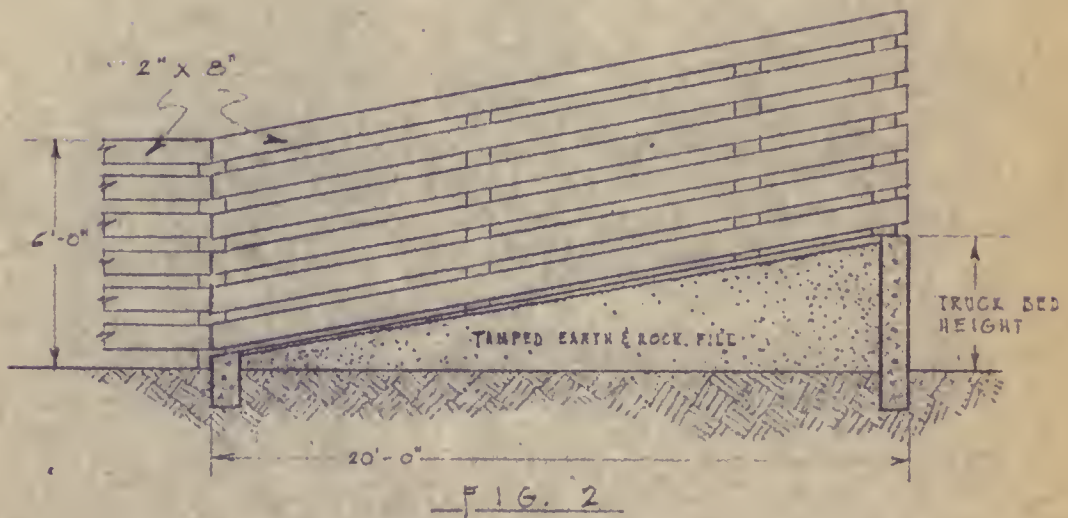
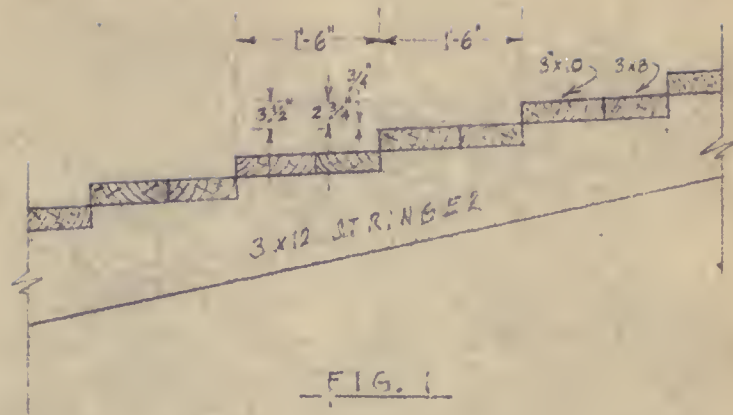

EXPLANATION PLATE XIV

Fig 1. Stepped-floor detail for portable chute.

Fig 2. Typical trailer mounted portable loading chute.

PLATE XIV

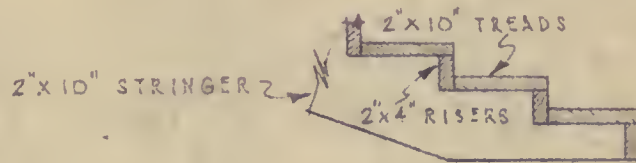

FIG. 1

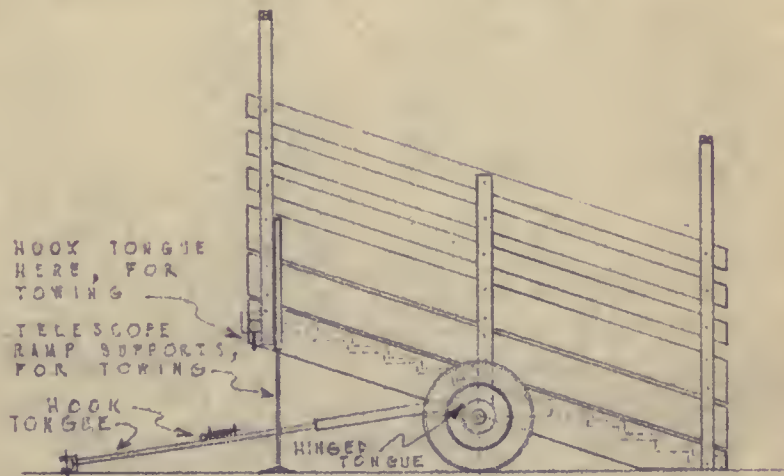

FIG. 2

branding or treating, and width adjustments at the base which make the equipment fit the various sizes of cattle to be worked. The squeeze chute is one piece of working equipment that can be purchased ready-made. It is a key piece of equipment for the treatment of cattle.

Spray Pens. The spray pen as previously mentioned is usually a dual job for some other part of the system such as the crowding pen, working alley, or working chute. Since this is the normal condition the discussion on this topic will deal with a few specific recommendations for a structure used for spraying. The fencing used for any of the above mentioned parts is adequate for the spray pen if provided with a catwalk. According to Huber (8) the catwalk seems to work best if it is four to four and one-half feet above the ground. It is also helpful if a top railing is placed about waist height above the catwalk to rest the spray equipment upon and keep it away from the cattle. A pen about eight feet wide and 20 to 30 feet long makes an excellent spray pen. The placement of a gate across the center of the pen will speed operations as it permits assembling one group while spraying another. One other requirement of a spray pen is it must have a floor covering material that will not get muddy with continued use. A good fill of eight to ten inches of coarse gravel, or rock makes a satisfactory floor. Another satisfactory floor would be a four-inch concrete floor over a sand or gravel bed. If concrete is used the surface should be left rough.

Scales. Although scales are not as common as the other parts mentioned previously they should be a part of the beef producers working equipment. They provide a means of measurement for the program. There are two types of scales in common use on farms today; the regular platform scales designed to weigh groups or individual animals and the small scales designed to weigh

individual animals. The second type is a new development in this area used by some producers of calves to determine individual weights at weaning time. When this is the type of scale to be used the proper location is at the end of the working chute just as the squeeze. In fact many of these scales are portable and are designed to take the place of a portable squeeze in the layout. The location of the regular platform scale is not this simple in most cases. The proper location for a scales is some where near the loading chute with a means of direct access to the chute and the crowding pens. It should, however, be placed so it can be bypassed whenever desired during working or loading. In many cases the operator wishes to weigh feeds and trucks on the scales as well as livestock which requires a location with access to the road system. If the operator plans to weigh trucks the problem of scale fencing and its removal is simplified if the platform is made nine feet wide instead of eight. This extra foot will permit weighing of the truck without removal of the scale pen. Most operators prefer to locate the beam house outside the corral proper. Some find a small building over the beam desirable because it protects the beam and eliminates some of the wind problem encountered with the open type beam cover, and it also provides an excellent place to keep records. The fencing for scales must be located on the edge of the platform. This is necessary to prevent inaccuracies in weight due to the animal being partly off the scale. The pens must be rigid and durable but in most cases removable with a minimum of work. When scales are properly located in a working corral system weighing is a very simple method of keeping tab on the livestock operation.

Gates. The gate is that part of the working corral upon which the

success of the system is hinged. Gates pose many problems in working corrals. Their construction and location are essential to efficient control. The ideal gate would have the following characteristics: it would be strong and durable, light and easy to manage, quick opening, and secure at the hinges and latches. Although many materials and designs are available for gate construction there is apparently plenty of room for future improvement in this part of the system. The wooden gate is most satisfactory for crowding areas it is strong and will withstand a lot of abuse. The weight of the gate is its biggest disadvantage, Adequate bracing must be used to keep this gate from sagging. Several gates are illustrated in Plates XV, XVI, XVII and XVIII. Metal prefabricated gates are light, easy to hang, easy to open, and they do not sag but they are subject to damage when rammed by livestock. They are therefore best suited for areas such as the holding pen where the crowding is held to a minimum. One additional problem encountered with metal gates which have a raw edge on the metal staves, braces, and fencing strips is the tendency for these semi-sharp edges to cut or scratch the cattle contacting them. The homemade metal pipe or welded rod gate is improved for use in crowding areas by adding two or three planks to make it easier to see. There are numerous devices used to hinge and latch the gates. Simple strong fool-proof equipment is best and most economical. Plates XIX, XX, XXI and XXII illustrate a number of the more common hinges and latches. The needs for the individual gate will often dictate which type of hardware is best.

Working Corral Layout

Working corral layout is the final stage in design, it involves a combining of the parts previously discussed into a working unit. The procedure

EXPLANATION OF PLATE XV

Fig 1. Typical entrance gate for working corral system. Note the spring latch and top brace to prevent post tilting.

Fig 2. Typical crowding gate in crowding pen. Utilizes slide catch, collar hinges and adjustable brace rod to prevent sag.

PLATE XV

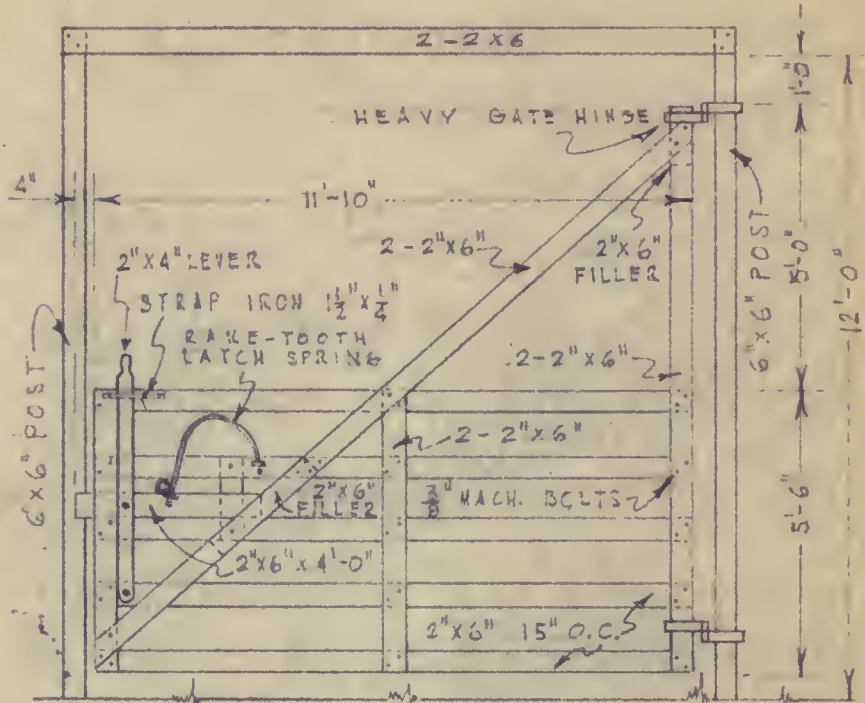

FIG. 1

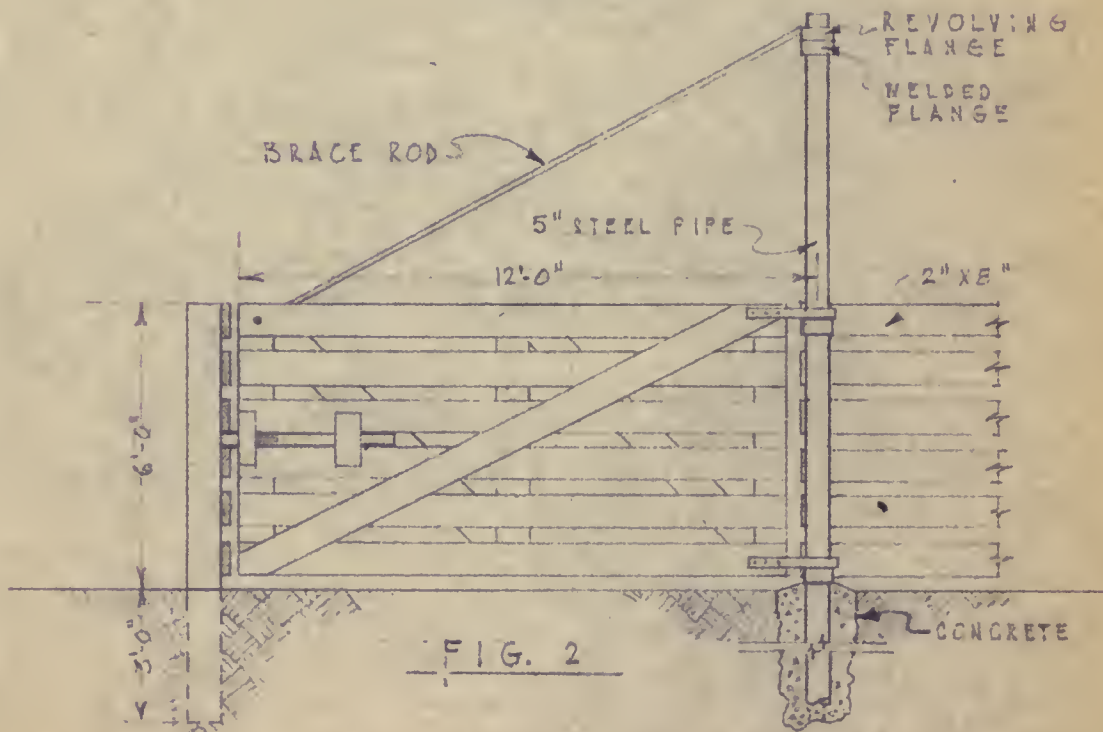
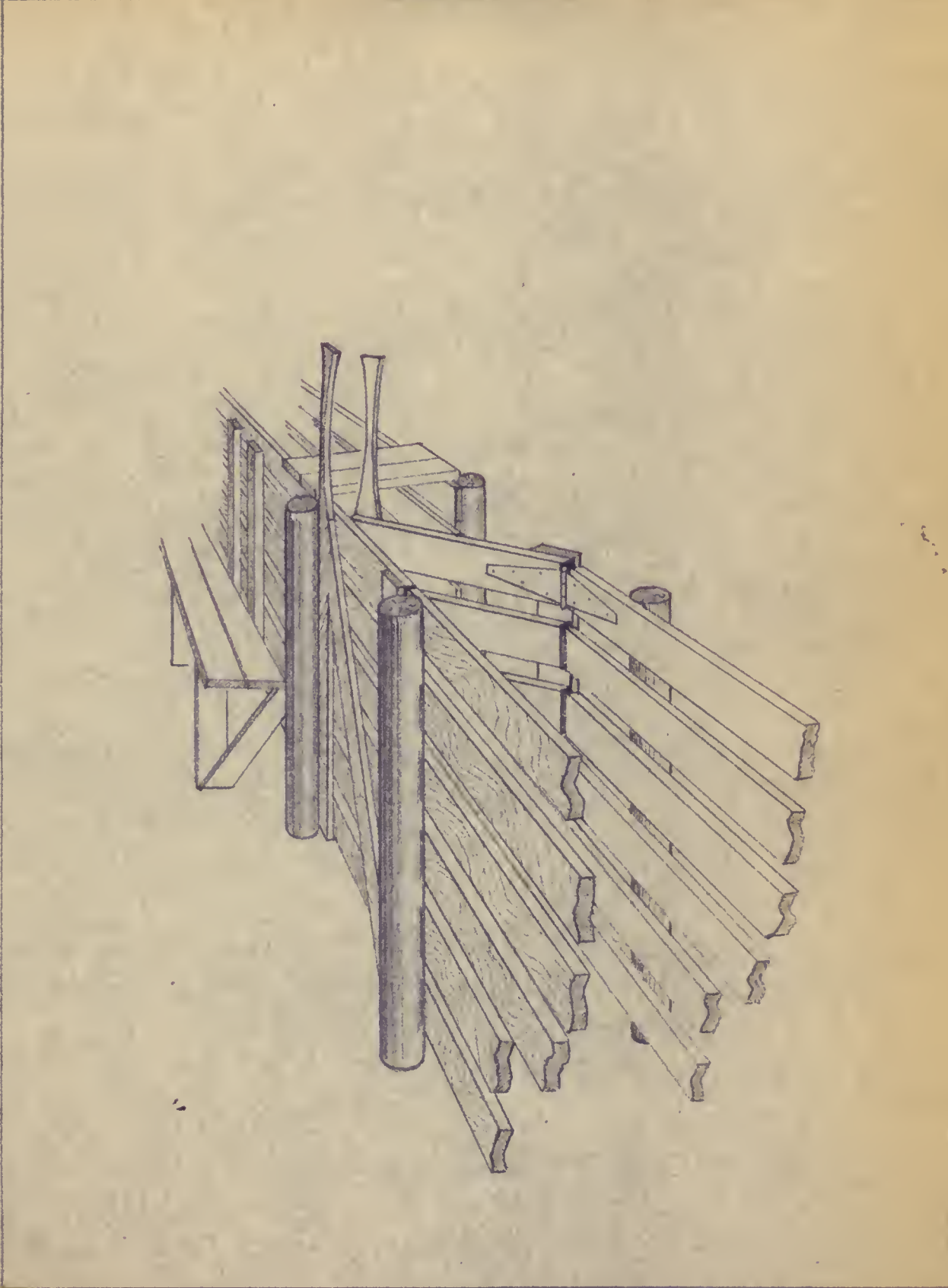

FIG. 2

EXPLANATION OF PLATE XVI

Isometric of typical cutting gates in working chute. Designed to operate from over head.

PLATE XVI



EXPLANATION OF PLATE XVII

Isometric view of telescoping gate suited to use on some loading chutes or where an adjustable gate length is needed.

PLATE XVII

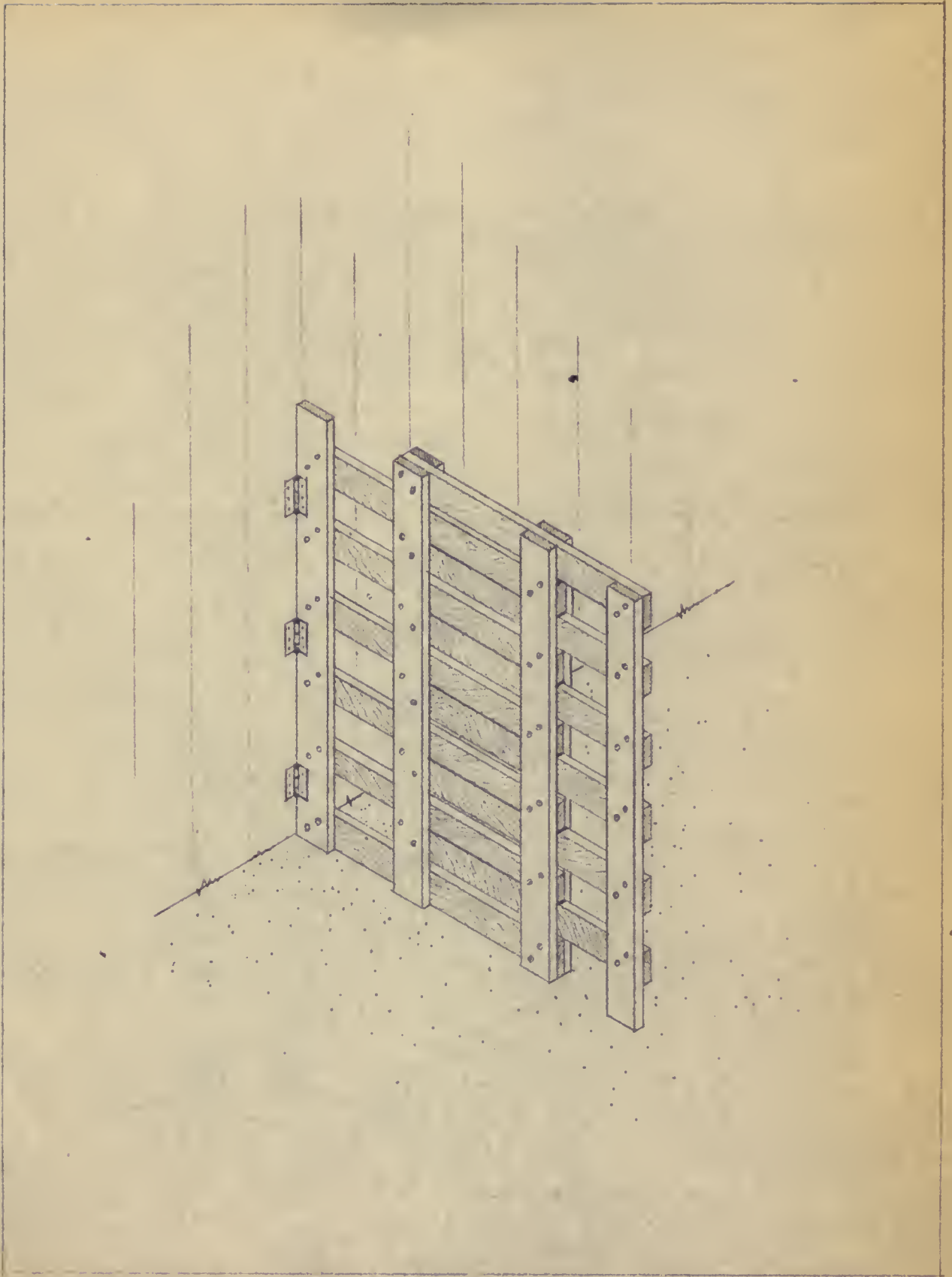

EXPLANATION OF PLATE XVIII

Isometric of typical concrete and pipe cattle guard type gate.

PLATE XVIII

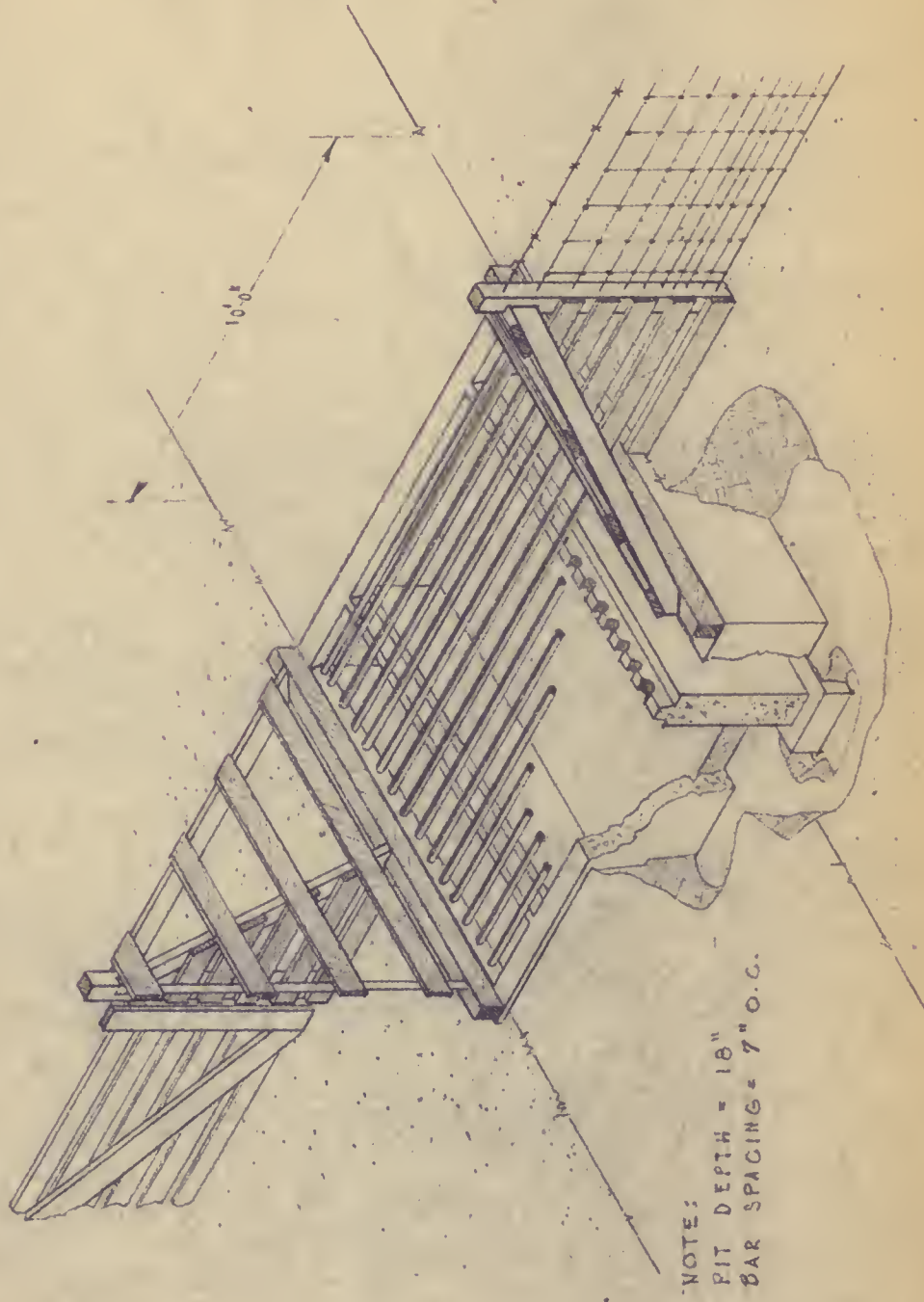

EXPLANATION OF PLATE XIX

Fig 1. Typical strap iron and bolt type hinge for gates.

Fig 2. Typical I-bolt, pipe and strap iron gate hinge.

PLATE XIX

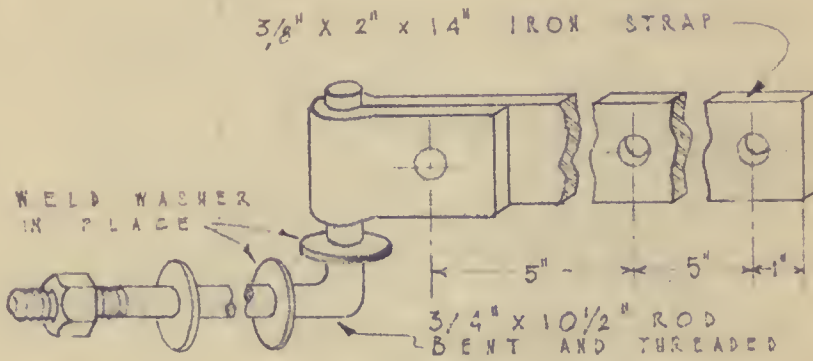

FIG. 1

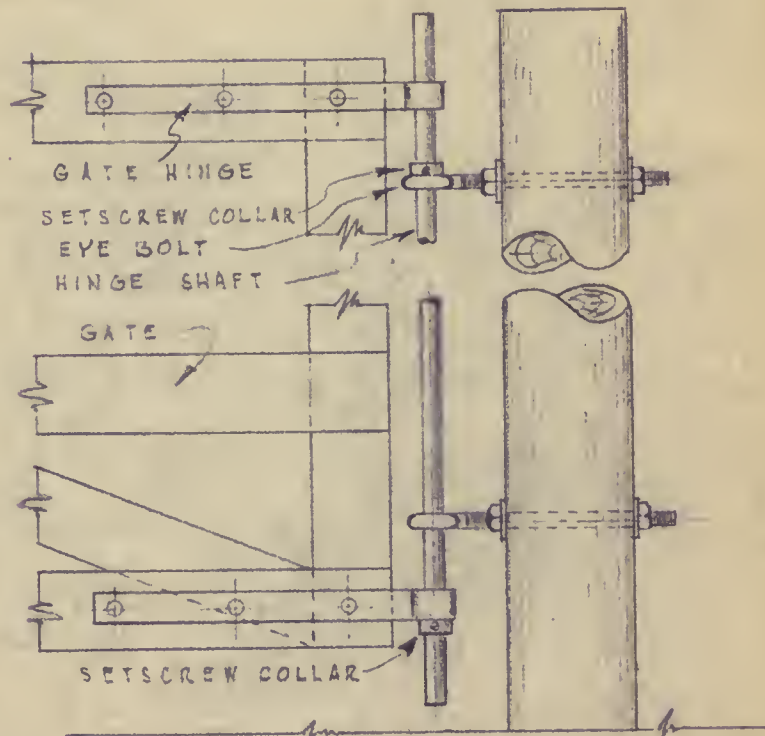
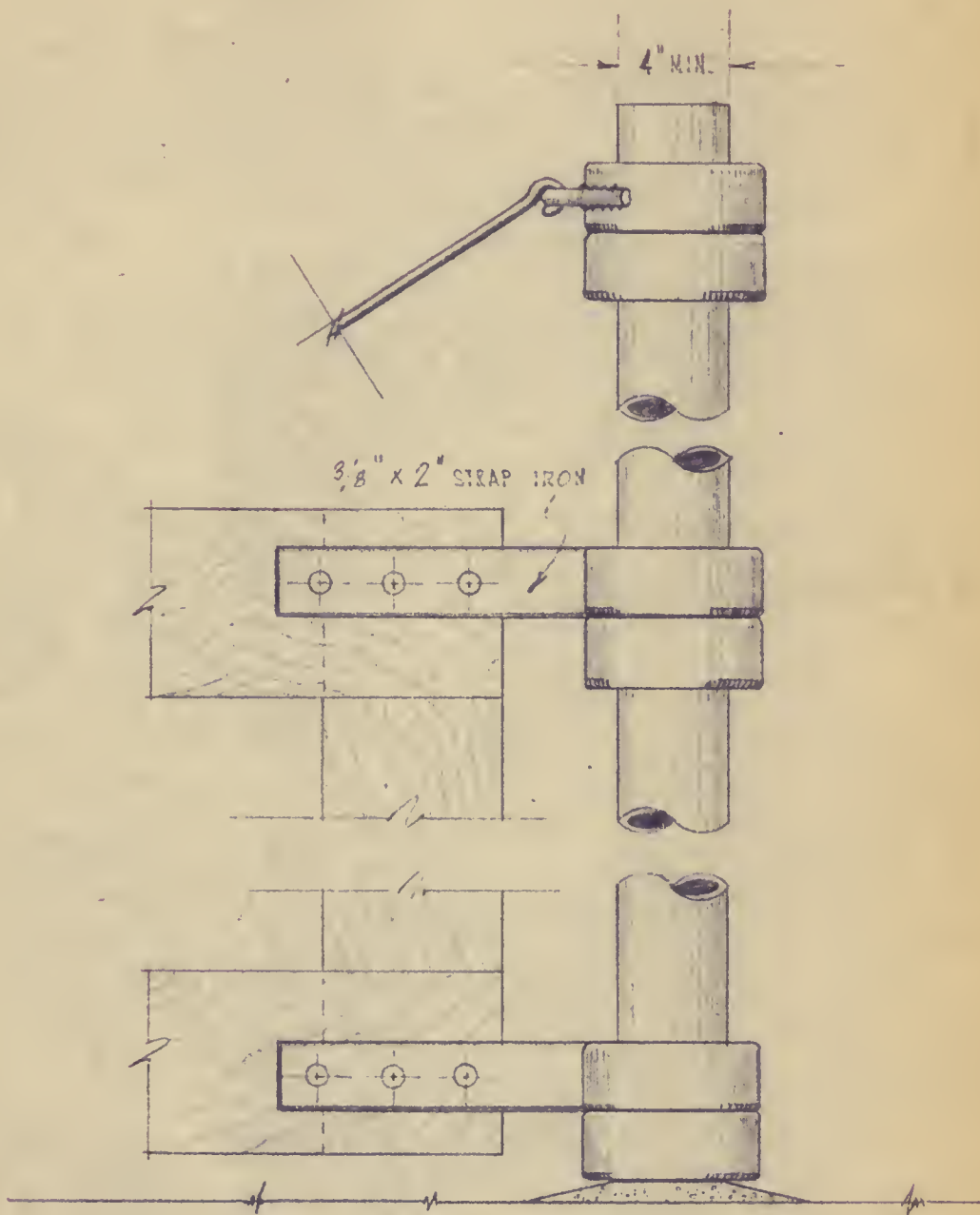

FIG. 2

EXPLANATION OF PLATE XX

A collar type strap iron gate hinge for crowding gates. A good hinge where a large swing angle is needed.

PLATE XX



EXPLANATION OF PLATE XXI

Fig 1. Sliding plank gate latch with hand lever at top.

Fig 2. Heavy hook and eye gate latch with locking block.

PLATE XXI

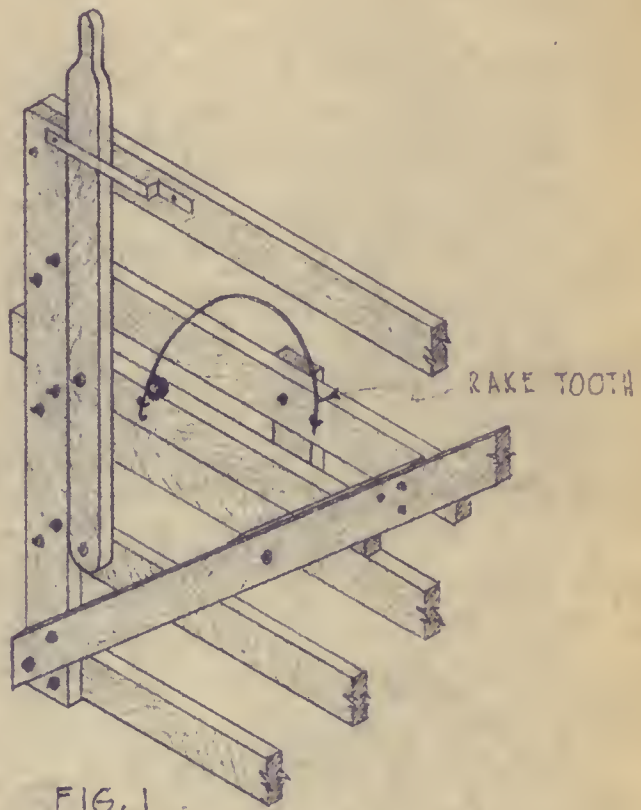

FIG. 1

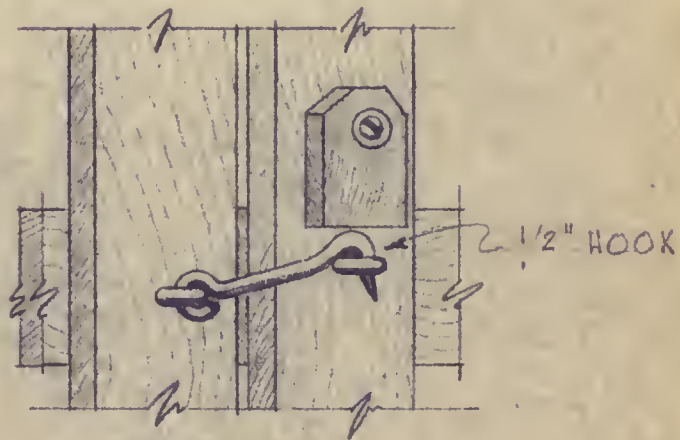
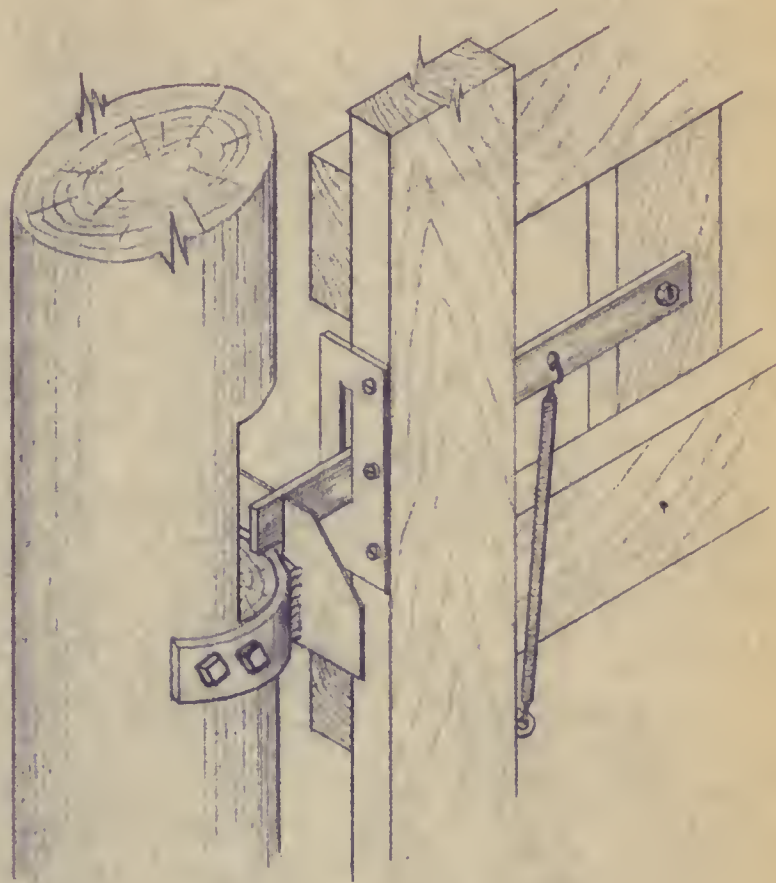

FIG. 2

EXPLANATION OF PLATE XXII

Isometric of simple spring activated self locking metal gate latch.

PLATE XXII



NOTE: USE $\frac{1}{4}$ " x 2" STRAP IRON

to follow in this phase is start with the essentials and work in special features as needed. The actual drawing or sketching of a plan to fit the site is probably the best method to use as it allows study and provides a record and guide to follow in construction. A good scale to use when preparing the sketch is to let one inch represent 20 feet on the ground. The use of cross section paper will aid in the preparation of the sketch. Plates VI, VII and VIII illustrate a number of sample layout sketches showing all parts assembled into a unit.

Summary. The following summary of basic principles and requirements will aid in preparing the actual layout. Convenience, safety, simplicity, and flexibility are the keys to a successful design. Before starting construction one should analyze the needs or requirements of the system. Select a well drained site easily reached and convenient to the livestock. The basic parts of a working corral are: holding pens, crowding pen, working chute, loading chute, and squeeze chute or head gate. Secondary features often needed include: spraying area, scales, cutting gates, and crowding gates. The basic requirements of the major parts are:

Holding Pen. Provide two lots as a minimum, allow from 20 to 70 square feet per head, locate with direct access to crowding pens, working chutes and an area from which cattle are assembled.

Crowding Pen. Select a location with direct access to holding pens and loading or working chute, allow a minimum of 400 square feet of area.

Working Chute. Select a working chute location with direct access from crowding pen leading into a holding pen; make chute from 25 to 30 feet long; keep width within limits for animals to be handled 30 inches top maximum for

mature animals.

Loading Chute. Select a loading chute location with direct access to the crowding pen or working chute and the road system for the site, provide an inside clearance of from 30 to 36 inches. Twelve to 16 feet of length is desirable.

Squeeze Chute or Head Gate. Place the squeeze at the end of the working chute with the outlet into a holding pen.

Scales. Select a scale location with direct access to crowding pen and loading chute but arrange so a by-pass of scales is possible if desired.

LIVESTOCK FEEDING LOTS AND EQUIPMENT

This portion of the study considers the automaton of cattle feeding. Included in this section is information on the design, layout, and construction of feeding lots, feeding bunks, self-feeders, and methods of distributing feed. The need for this equipment is universal to the livestock business. Every producer large or small must provide some means for feeding and needs to develop a method of doing the job. There is no phase of livestock management that offers more opportunity for increasing production labor efficiency at less cost. A few of the ways feeding equipment can aid the livestockman are:

1. Reduce the labor requirement for feeding the livestock.
2. Reduce the loss of feed due to wastage from poor or inadequate equipment.
3. Reduce the investment cost per year by providing more durable and useful feeders.
4. Promote higher production efficiencies through more satisfactory and

sanitary conditions for the livestock.

A realization of these savings is possible when sufficient thought and planning is done by the producer. The information to follow is prepared to serve as a guide in this planning. It represents an attempt to consolidate the basic data needed to establish an effective efficient feeding system.

Feeding Lots

The feeding lot maybe defined as the corral or corrals in which the feeding is to be done. The normal location for feeding corrals is near the farm headquarters adjacent to available livestock shelters. Such a location is generally considered easiest to manage or supervise and most convenient. If however there is no suitable site at the farmstead very good feeding lots can be developed elsewhere. The basic requirements of a good feeding corral site are; good drainage, not subject to flooding, adequate protection, access to a road system, good water supply, and convenient to the feed and livestock. Additional factors to consider when locating the lots are: prevailing winds, the direction of drainage, and the availability of electrical energy. One should try to locate corrals so drainage is away from the farm yard or home. A slope of two to four percent is adequate for most soils. Select a location where the objectional odors and dust from the lot will be blown away from the home by prevailing winds. A site with a southeast slope is preferred as it will dry quicker and be warmer during the winter. Good protection for corrals can be obtained from windbreaks, bluffs, and buildings to the north and west of the site. A minimum distance of 150 to 200 feet is recommended between the house and the corral.

The fence used for feeding corrals must be strong and durable. Any of the illustrated holding pen fences in Plates I, II, and III are considered suitable. When wood products are used for posts, fencing, or feeding equipment, the use of pressure treated wood is recommended. The size of corral needed is determined by such factors as drainage, the type of soil, lot surfacing, and the livestock program. The general space recommendation varies from 75 to 500 square feet per head. More specific recommendations for different age groups normally handled are as follows:

1. Mature animals, wintering program, 500 square feet per head.
2. Yearling steers or heifers, wintering program, 300 to 500 square feet per head.
3. Calves, wintering program, 100 to 300 square feet per head.
4. Steers or heifers, full feeding lot, unsurfaced except around feeders, 150 to 200 square feet per head.
5. Full feeding lot, surfaced, 75 square feet per head.

These figures assume average drainage and normal soil conditions. On poorly drained sites or areas with soggy soils it is suggested that the space recommendations be increased 50 percent except when surfaced. In extreme cases surfacing may be the only satisfactory solution.

The number of lots or pens to provide will be determined by the normal divisions needed for the management program. The minimum number recommended is two pens. Even in cases where all animals are handled in one group at least two pens are desirable. Providing more than one pen adds flexibility and convenience to the system. The shape of feeding corrals is adjusted to fit the site and the feeding system. For economy of fencing the square pen is best but it may not satisfactorily fit the local conditions. For example

if fence line feeding is planned a rectangular arrangement may be necessary when only one side of the lot is suitable or available for feeders. Under these conditions a depth of 100 feet will provide all the corral needed for the feeder space available. Since the livestock often move directly from these corrals to market, or need to be worked while in the corral, it is desirable to provide working corrals centrally located to the feeding lots. When this is done the corrals can serve as the holding pens. Several feeding corral layouts are illustrated in Plates XXIII, XXIV, and XXV along with labor saving arrangements of feeding equipment.

Feeding Bunks

Feeding bunks are one type of structure into which feeds are placed for the cattle to eat. The purpose of these structures is to provide a means of holding the feed while being eaten which will prevent unnecessary waste or loss of feed. Three types of feeding structures are classified as bunks in this study, they are: box feeders, racks, and fence line feeders. Self-feeders and feed distributing methods will be discussed separately. The type of feeder to select should be determined by the feed, the method of handling the feed, and the livestock program. All of these feeders can be made either portable or permanent structures.

The Box Feeder. This type of feeder is the best selection for feeding grain or silage in a corral. It consists of a round, square, or rectangular box like container supported on a foundation or legs. The method used for filling determines which shape will be most efficient. When the feed is dumped into the feeder with equipment such as a front-end-loader on a tractor a circular or square feeder is easier to use as it can be filled with less

EXPLANATION OF PLATE XXIII

Typical corral layout for permanent feeding arrangement from upright silo into lots with hay storage and shelter.

PLATE XXIII

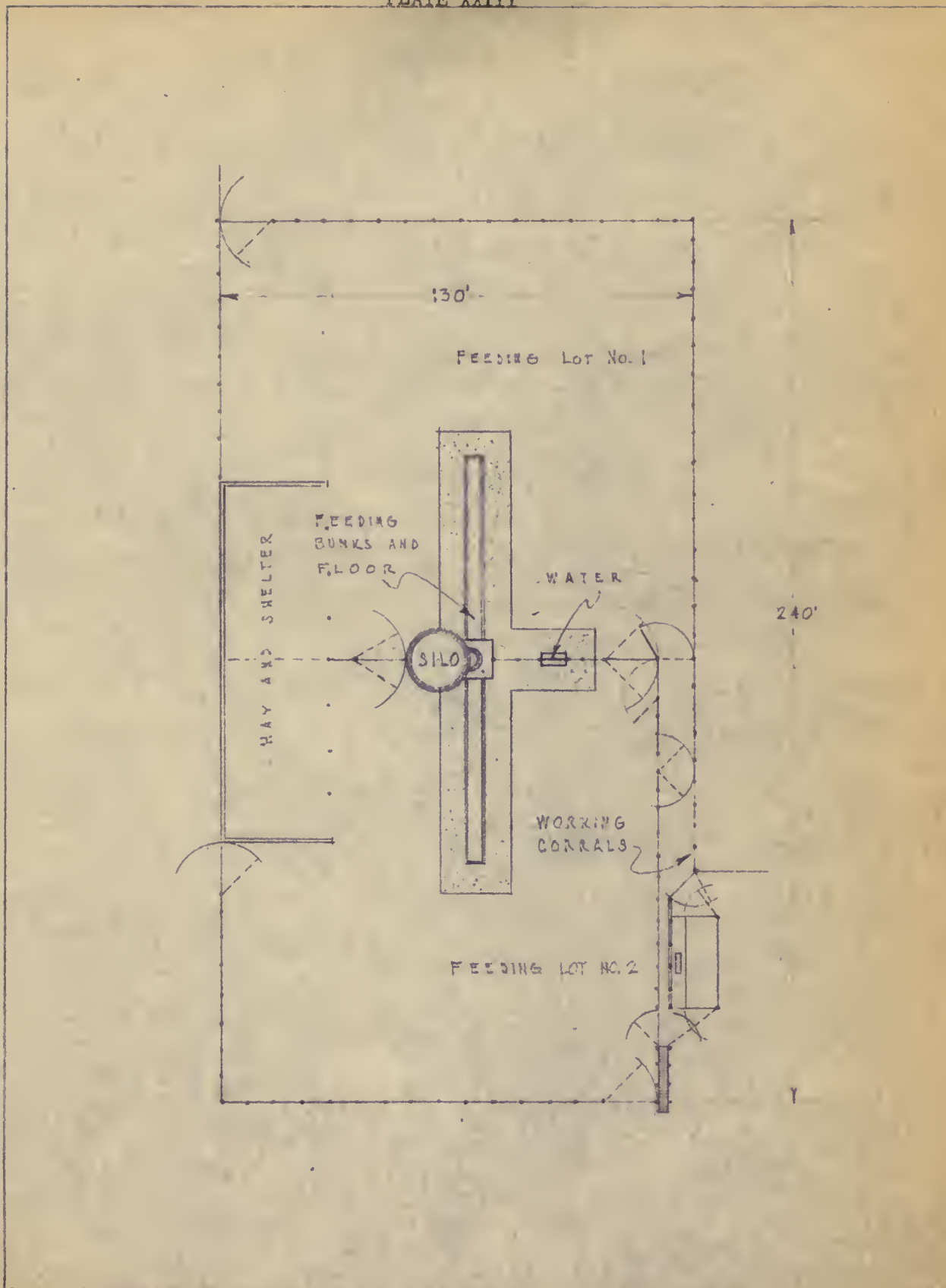

EXPLANATION OF PLATE XXIV

Typical two pen feeding corral with fence line feeder, and working corral layout. Hay fed directly from storage.

PLATE XXIV

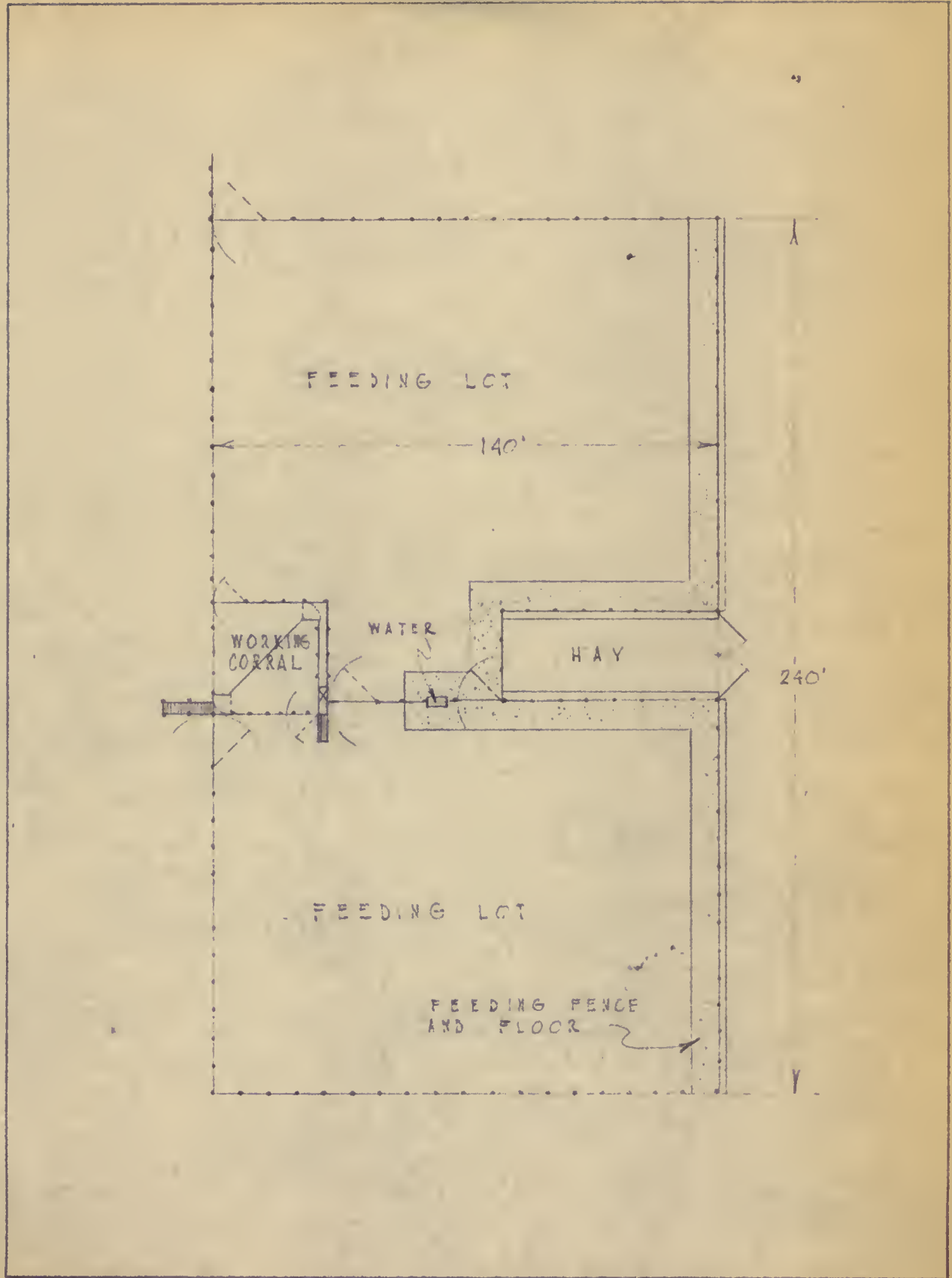

EXPLANATION OF PLATE XXV

Typical feeding corral layout for commercial or large feeding operations. Includes: fence line feeder, feeding alley, and working corrals with scales.

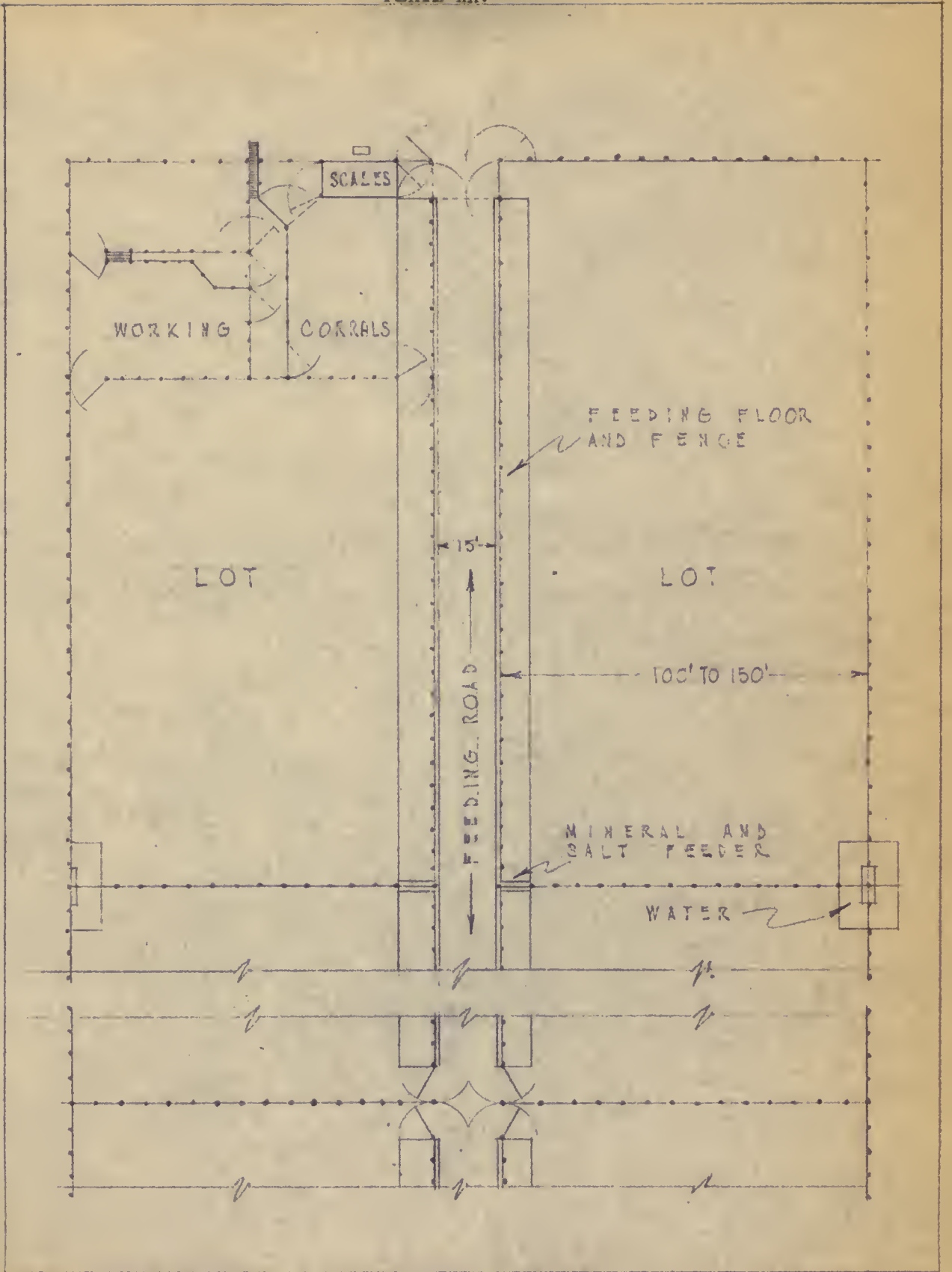

loss due to spilling. When the feeder is filled by hand or with a power unloading wagon the rectangular shape is preferred. For these bunks to be effective the cattle must be able to eat the feed from them without a need for labor other than filling. This requirement has resulted in the development of specific recommendations regarding the size of this equipment. The more important size recommendations for box feeders are as follows:

1. Width of feeder, feeding from both sides, 42 to 48 inches. If a wider space is used a center cone or inverted "V" slide should be used to force feed to the edge within reach of the cattle. Thirty inches is the maximum effective reach for cattle.
2. Throat height of the feeder may vary from 20 to 30 inches. The lower heights of 20 to 24 inches are best except in full feeding lots where hogs are running with the cattle in this case height is needed to keep the hogs out of the grain and feeder. The advantage of the lower height is that it fits both small and large animals.
3. The depth of the feed box may vary from a minimum of eight inches to a maximum of about 20 inches. The shallow box is suited to grain and concentrate feeding only. The deeper boxes can also be used for silage and chopped or baled hay if desired. There will usually be less waste from the deeper boxes. Fourteen to 18 inch depths are excellent for all purpose feeders.
4. The length of feeder space per head required depends on the size of the cattle. It will vary from 18 inches on calves to 30 inches on bulls. The most generally accepted design space allocation is two feet of feeding space per head.

The main construction requirements for these feeders are they must be

strong and durable. Good feeders can be made from any of the standard building materials metal, wood, or concrete. Typical construction details are illustrated in Plates XXVI and XXVII. Suggested arrangements of feeders for convenience are illustrated in Plates XXIII and XXIV.

Feeding Racks. Those structures used for the feeding of hay are called racks. Equipment of this type is of two basic designs the slatted feeder and the manger type feeder. On the slatted feeder the cattle secure the hay by pulling a mouthful through a framework of metal or wooden slates. In the manger type rack the cattle eat the hay directly from the manger. As a general rule the slatted feeder is preferred for loose hay and the manger is preferred for baled or chopped hay. The primary advantage of the slat feeder is its self-feeding characteristic. When filled, all the hay placed in the feeder can be fed without additional work. It is however somewhat difficult to fill with baled or chopped hay. There is also evidence to indicate the waste with this feeder is a little higher than the other types studied. This is very true if the feeder is not provided with a tray or box to catch the dropped leaves. The explanation offered for this extra waste is the cattle secure a mouthful of hay and back away from the feeder thus dropping the excess under their feet. Careful spacing of the slats to prevent securing too much extra hay at one time will aid in controlling the amount lost. See Plates XXVIII and XXIX for specifications. In addition to the advantages already mentioned for the manger feeder it is well adapted to rationed hay feeding and quite often the feeder can also be used for silage and grain. The small hay capacity of this feeder and the need for additional hand feeding in the rack are the leading disadvantages for this feeder. Studies conducted on this type feeder by Brennen(2) indicated the waste or loss of hay form

EXPLANATION OF PLATE XXVI

- Fig. 1. End cross section view of a "V" bottom portable wood feed bunk.
- Fig. 2. End cross section of a permanent cast in place concrete feeding bunk.

PLATE XXVI

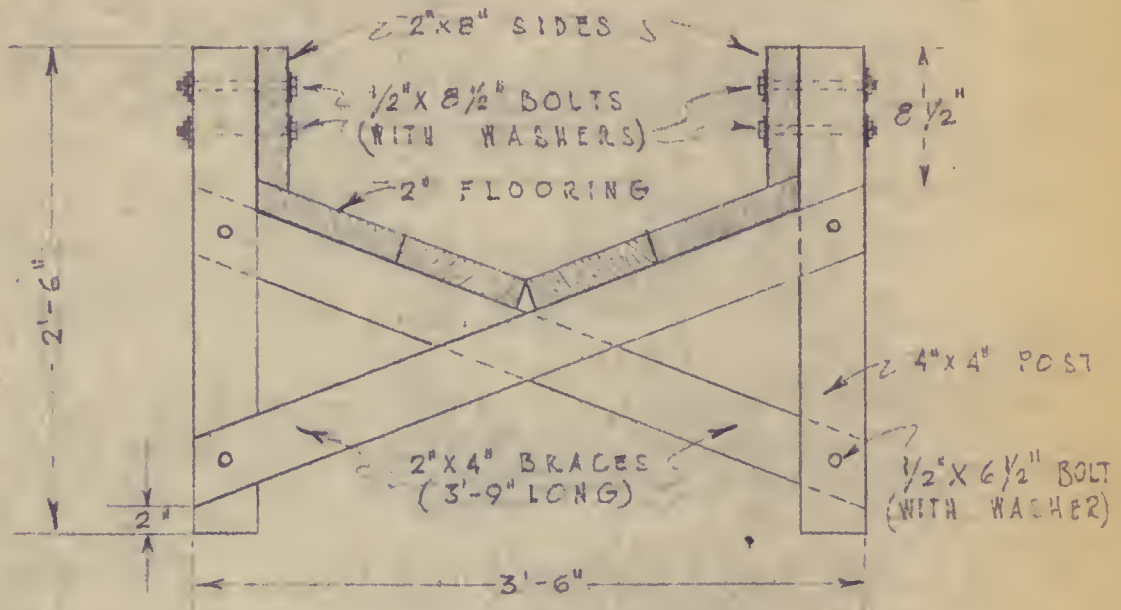

FIG. 1

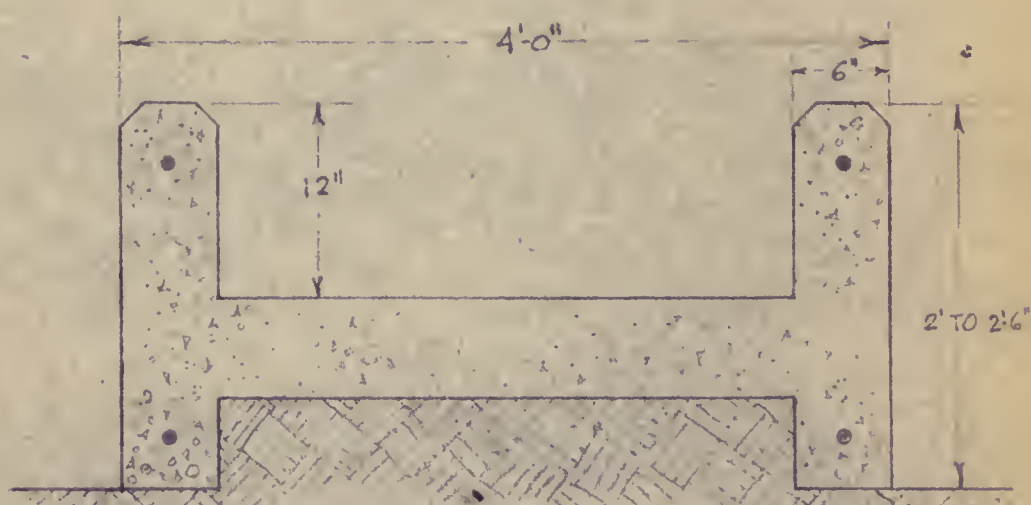
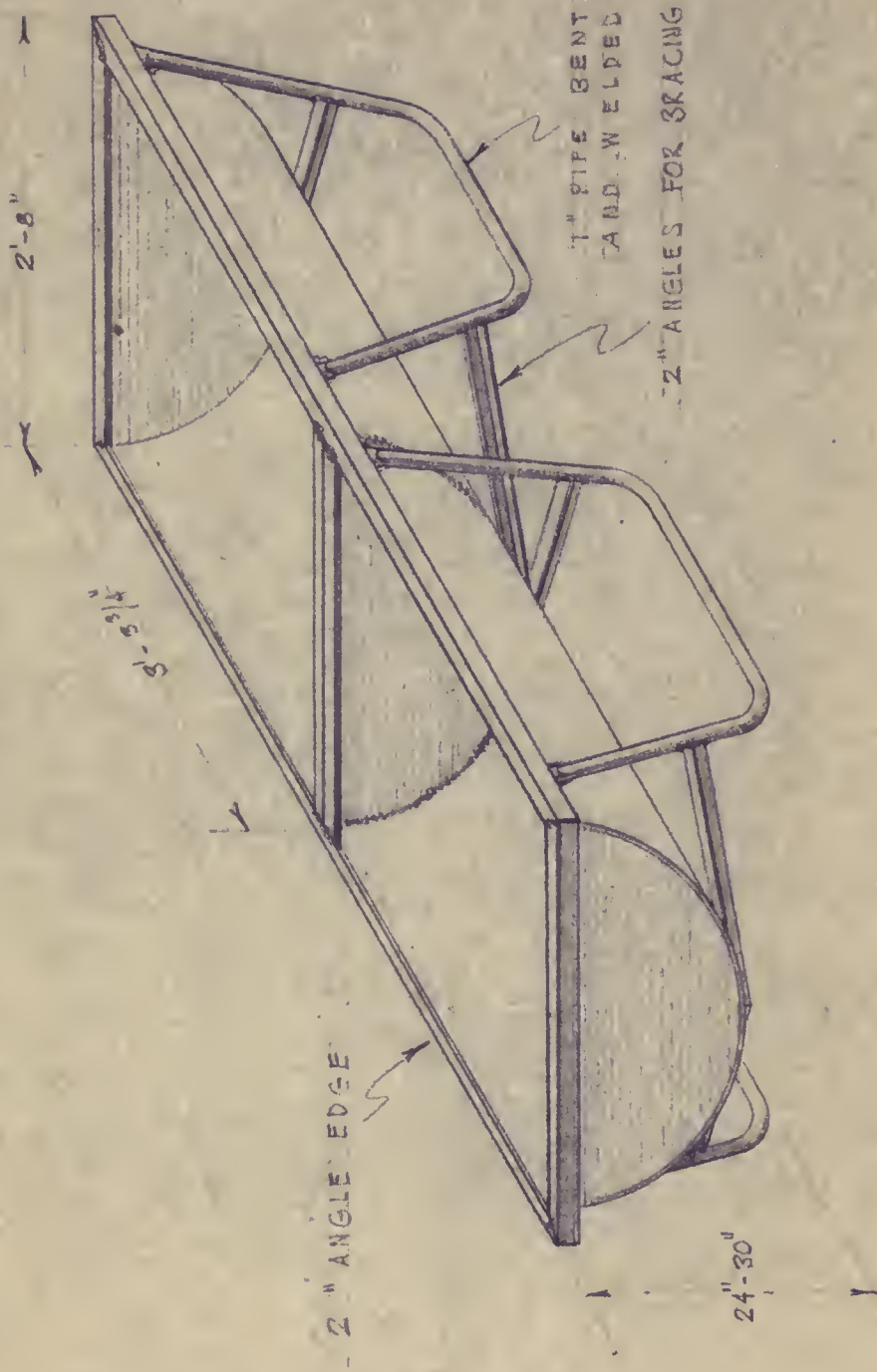

FIG. 2

EXPLANATION OF PLATE XXVII

Isometric view of a metal barrel feeding bunk.



EXPLANATION OF PLATE XXVIII

A trailer mounted slat type hay feeding rack.

PLATE XXVIII

NOTE: CORRUGATED
METAL ROOF OPTIONAL

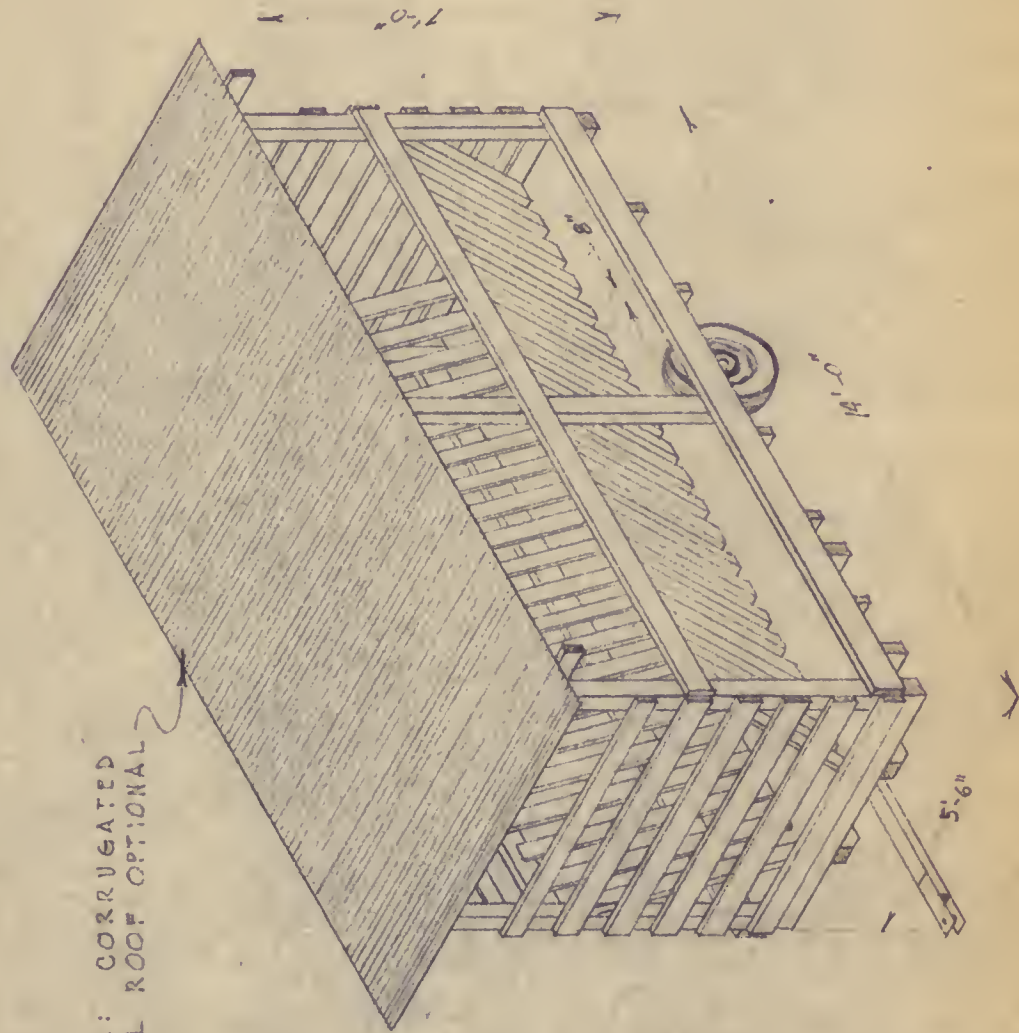

EXPLANATION OF PLATE XXIX

A skid mounted slat type hay feeding rack.

PLATE XXIX

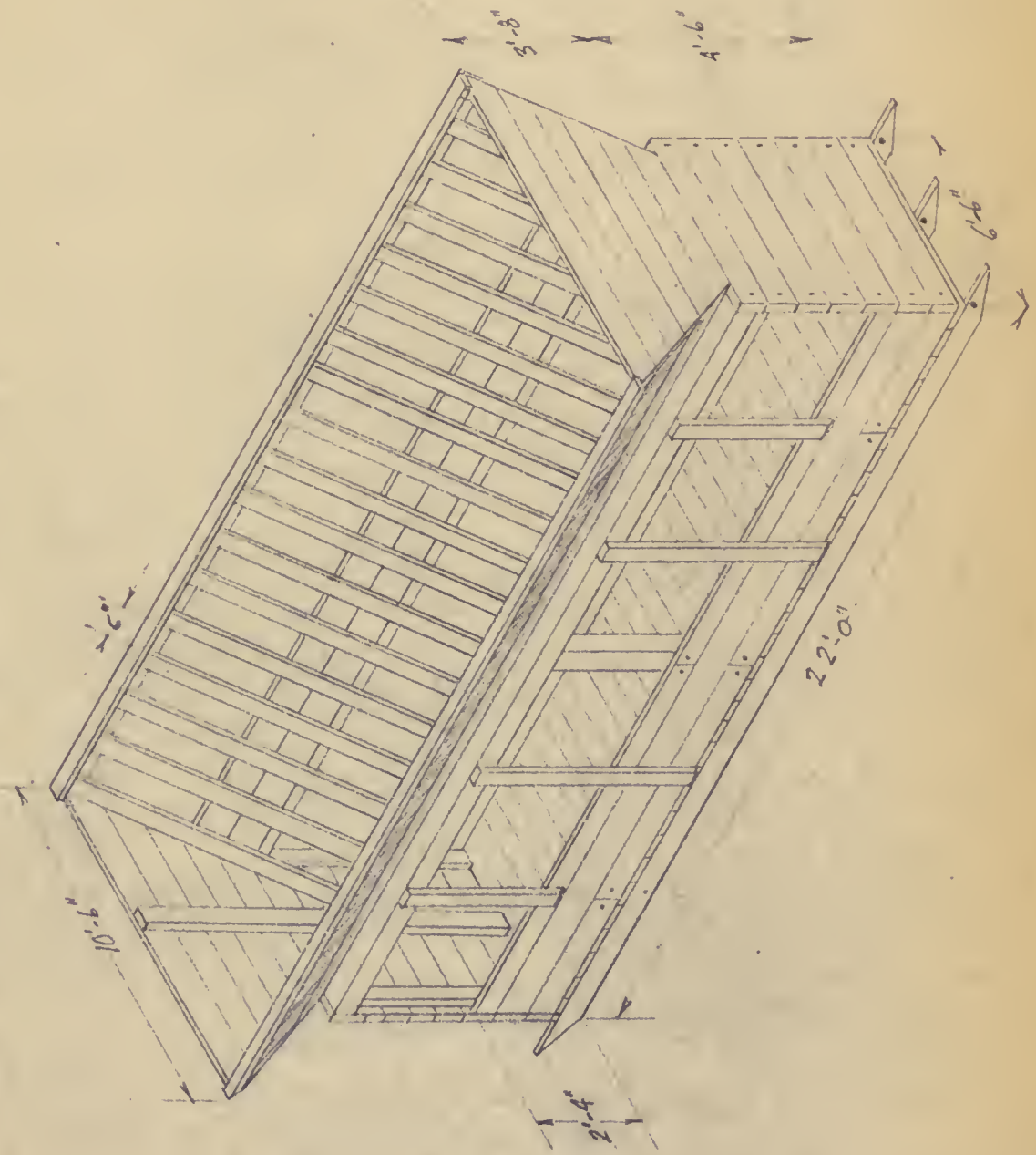

this feeder is reduced if the manger is divided into stalls with eleven inch gaps and the feeder not over filled. Maximum recommended filling height was six inches above throat height. For additional information on the construction of this type hay feeder consult Plates XXX and XXXI.

Fence Line Feeders. Building the feeding equipment into the fence is the newest addition to the general field of feeding bunks. These feeders are of both the box and manger type construction. They are being used for feeding all livestock feeds hay, silage, and grain. The fence line type of feeder is very well adapted to use where the feeds must be hauled for feeding. The manger type fence feeders are well adapted to use for feeding hay which is stored adjacent to the lot fence or around an inclosed hay storage area in the corral. The fact that fence line feeding can be done from outside the corral makes this a very good feeder for modern equipment. It eliminates the need for opening and closing gates to feed and keeps the feeding equipment out of the corral mud. The disadvantages of this system are: it takes twice as many feet of feeder length since feeding is from one side only, and the feeders are generally permanently located which reduces their flexibility. One problem common to all permanent feeding arrangements is continual feeding in one area makes it necessary to install a feeding floor to keep the cattle out of the mud and keep the soil from blowing or washing away from the feeders. The most satisfactory feeding floor is a concrete slab. Minimum specifications for a concrete feeding floor are: depth four inches over a four to six inch gravel or crushed rock fill, and width eight feet. The floor should slope away from the feeder at least one-fourth inch per foot and have a rough top surface. The outer edge of the floor should have a lip or foundation which extends

EXPLANATION OF PLATE XXX

A skid mounted manger type hay feeding rack. Feeding spaces divided with vertical dividers.

PLATE XXI

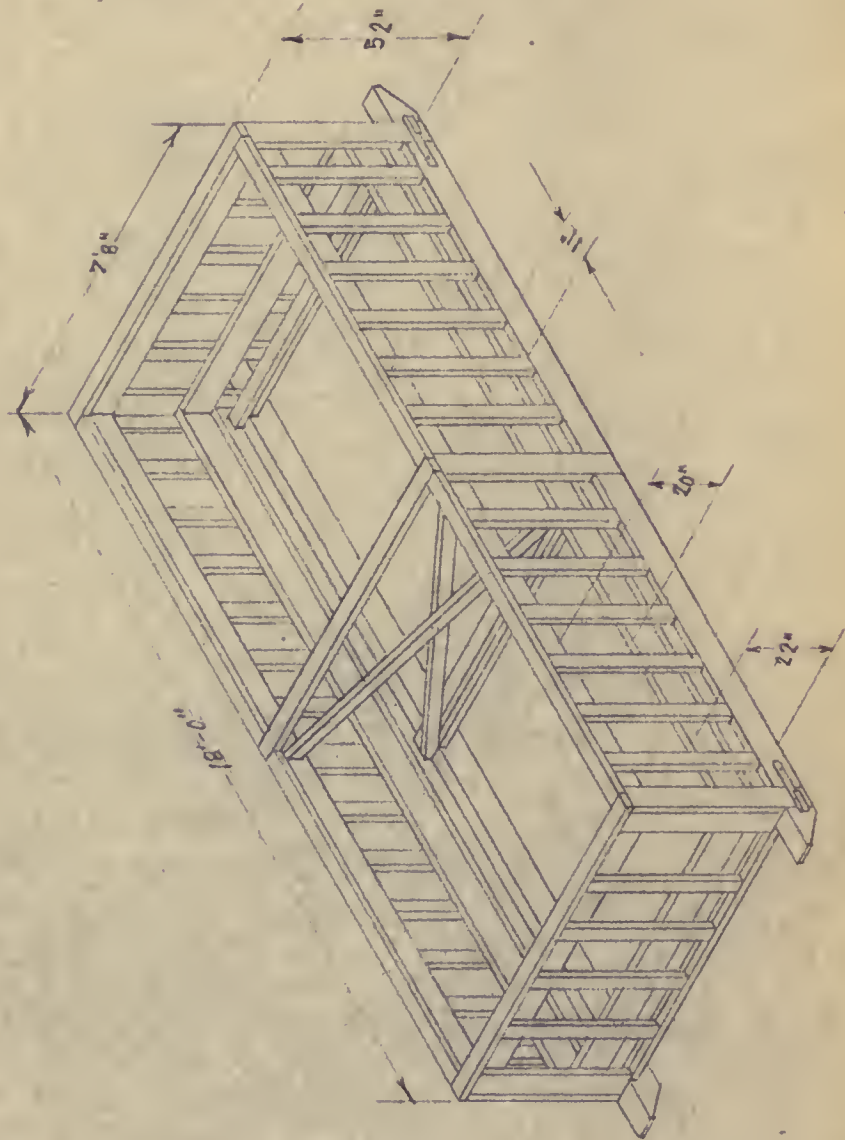

EXPLANATION OF PLATE XXXI

Isometric view of small skid mounted "W" stall
hay feeding manger.

PLATE XXXI

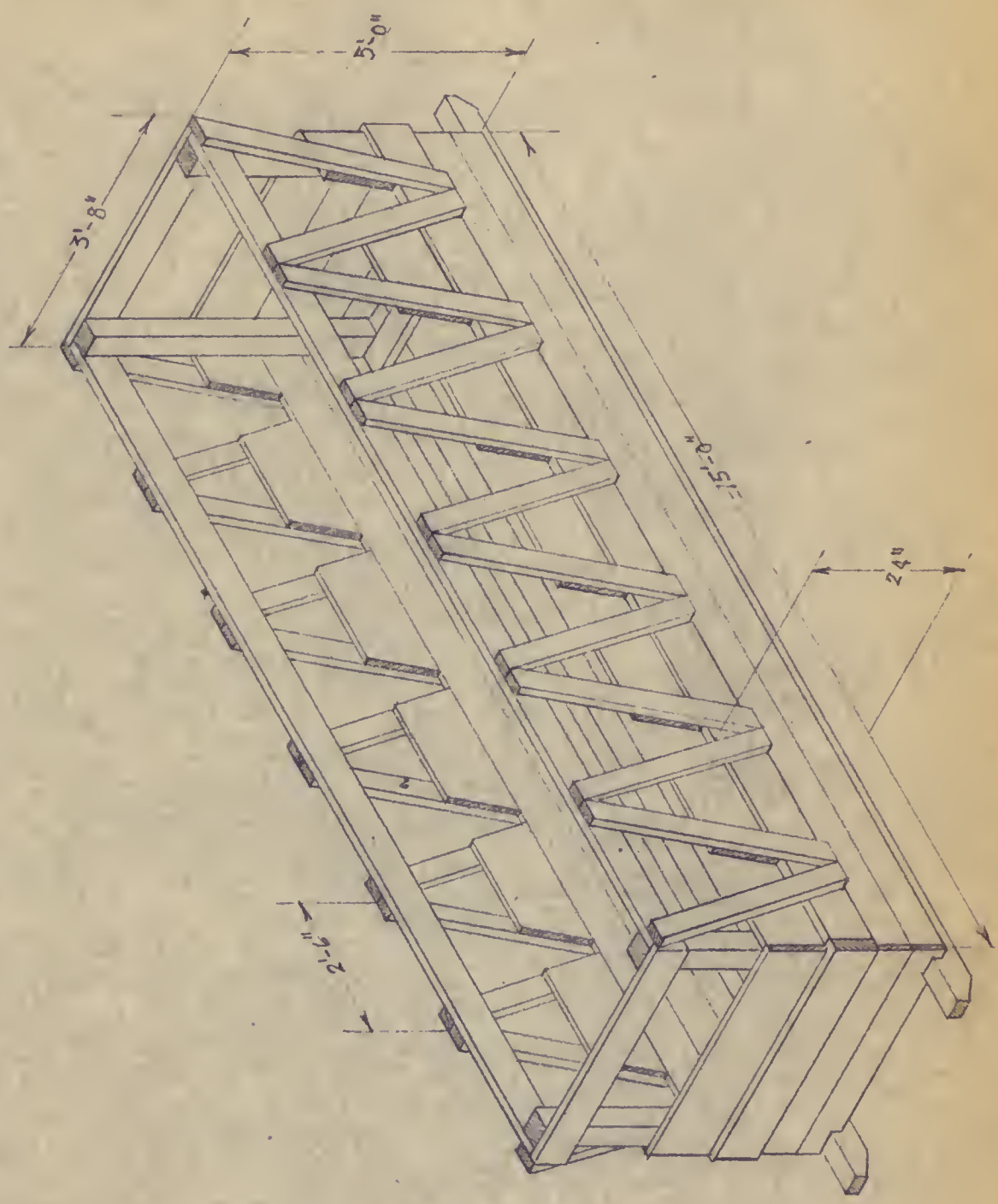

into the ground at least 15 inches to strengthen this section and prevent undermining by rats. A wire mesh reinforcing will add stability to the floor and aid in preventing irregular settlement if the floor should crack. Quality concrete should be used and recommended placing and curing practices followed.

Fence line feeders may be of either wood or concrete construction.

The basic size recommendations for these feeders are:

1. Width of feeder at bottom, 30 inches maximum, 18 to 24 inches being preferred. Width at the top of the feeder approximately 30 inches. A flat bottom bunk is preferred as it is easier to clean.
2. Throat height, may vary from 18 to 26 inches. Heights of 20 to 24 inches are preferred.
3. The height of the back retaining wall of the bunk should be approximately 30 inches. This aids in keeping waste to a minimum.
4. The feed box depth should be from 12 to 18 inches. This places the feeder bottom from six to ten inches above the ground level.
5. The opening between the feeder throat and the fence rail above the feeder will vary from 18 to 24 inches. The opening is made adjustable in most cases. Placing this rail on the outside of the fence reduces some pushing on the fence and aids to keep cattle from wearing a "bald-spot" on the top of their neck. For additional construction and design data on fence line feeders see Plates XXXII and XXXIII.

Self-Feeders

Self-feeders can and are being used by cattlemen to feed all major feeds such as grain, hay, and silage. The use of this equipment may require a few

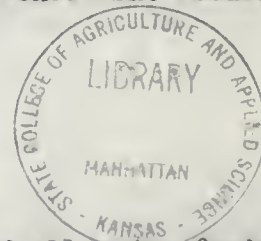

EXPLANATION OF PLATE XXXII

Fig. 1. Typical cross section of concrete cast in place
fence line feeder including feeding floor.

Fig. 2. Cross section view of wood fence line feeding
manger.

PLATE XXXII

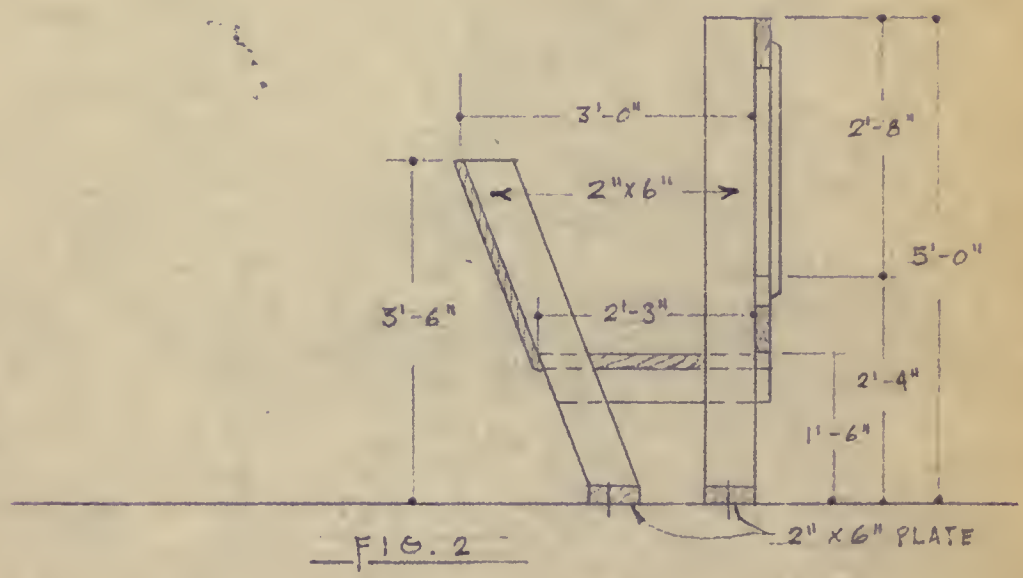
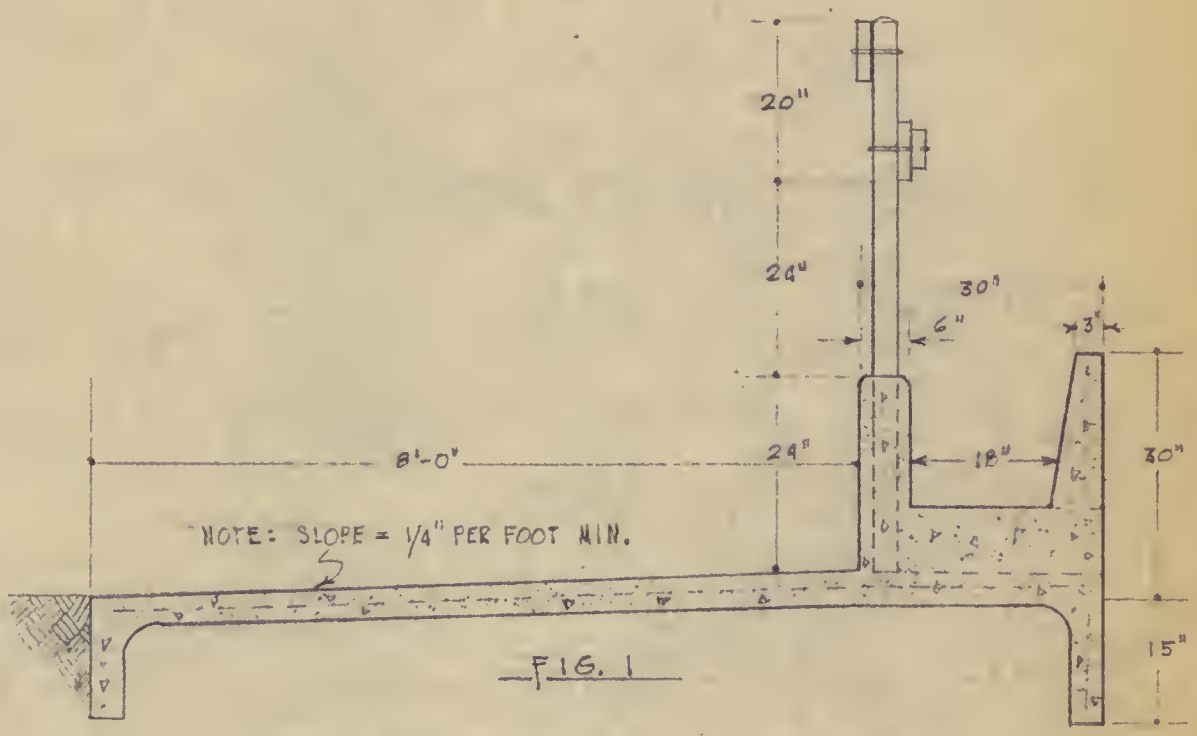

EXPLANATION OF PLATE XXXIII

Fig. 1. Typical combination wood and concrete fence line feeders with feeding alley or roadway.

Fig. 2. Isometric of box type fence line feeder for power-scoop feeding. Includes a cone to distribute feed to edges.

PLATE XXXIII

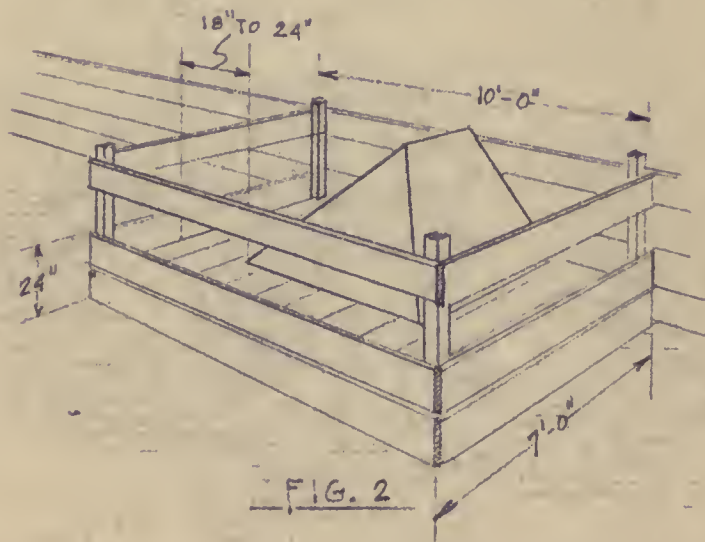
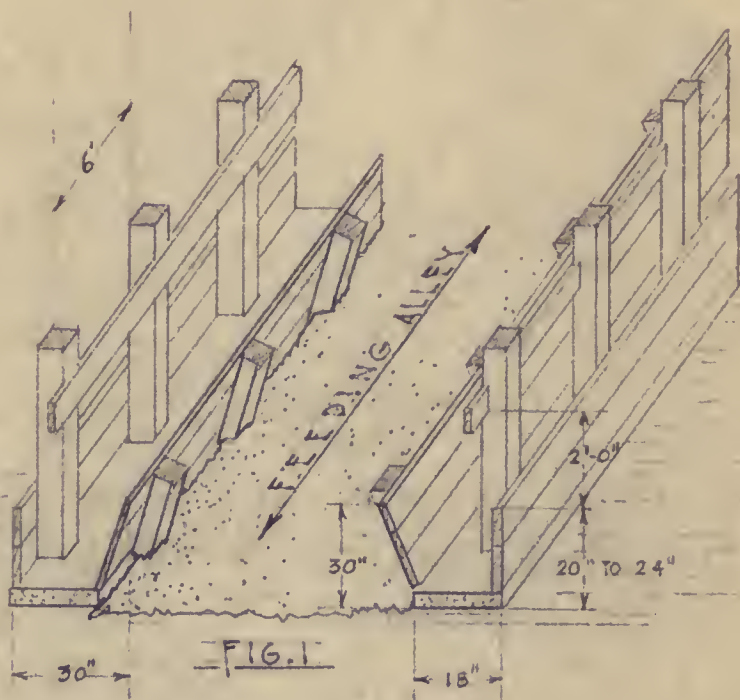

managerial changes to be successful. These feeders offer opportunities for great savings in labor combined with good feed utilization. Labor savings of up to 80 percent over conventional hand feeding is possible with self-feeding.

Self-feeders for Grain. A grain self-feeder is essentially a hopper bottom bin with a built-in feed bunk below. The size of feeder is adjusted to the number of animals to be fed and the amount of feed processed at one time. The recommended amount of feeder space per head is from six to nine inches. One of the greatest uses for a self-feeder in beef production is with the creep feeding program. These calves can use the feeder almost from birth to market. Plates XXXIV and XXXV illustrate very good feeders for this production program. The basic requirements for grain self-feeders are the same as that of the creep feeder except the size may be adjusted to fit the cattle. It is desirable to have enough roof overhang to protect the grain from getting wet. Placing the feeder at right angles to the prevailing wind is recommended.

Self-feeders for Hay. The use of hay self-feeders has been limited to chopped or ground hay. The more practical structures in use serve a combined purpose as hay storage and self-feeder. In addition the facilities for drying hay are also included in many cases. The use of this equipment permits curing a higher quality hay. Feeding directly from storage eliminates most of the hay feeding labor. Self-feeding hay structures are of two basic types. One type utilizes horizontal storage and the other vertical storage. The horizontal feeder is similar to a grain self-feeder except it is much larger. The vertical storage structures may be farm built or purchased as a prefabricated building. Plates XXXVI and XXXVII illustrate the construction

EXPLANATION OF PLATE XXXIV

Isometric of Kansas Creep Feeder plan including detachable telescoping welded pipe creep fence.

PLATE XXXIV

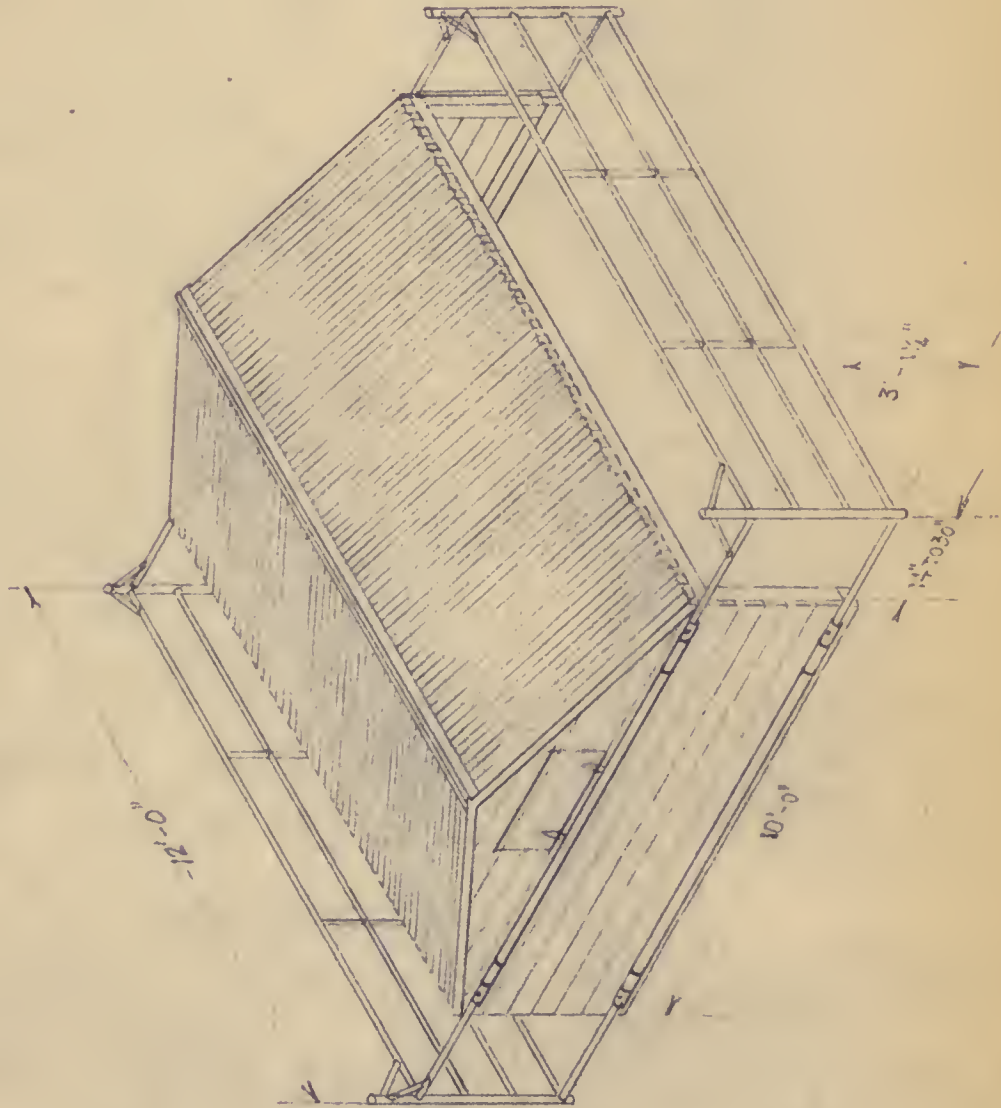

EXPLANATION OF PLATE XXXV

Cross-section of typical grain self-feeder cross section.

PLATE XXXV

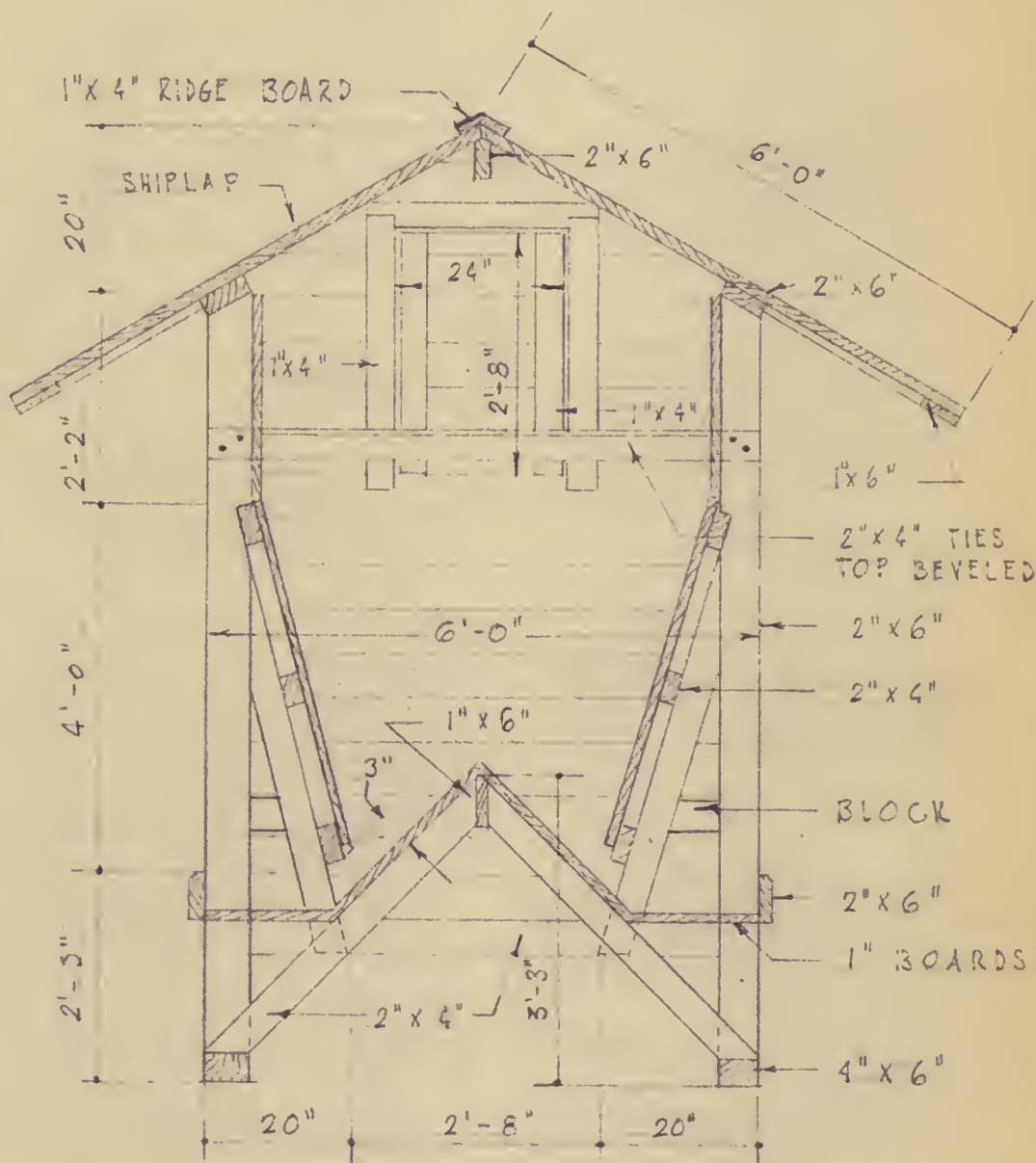

EXPLANATION OF PLATE XXXVI

Cross-section of a typical horizontal chopped hay self
feeder.

PLATE XXXVI

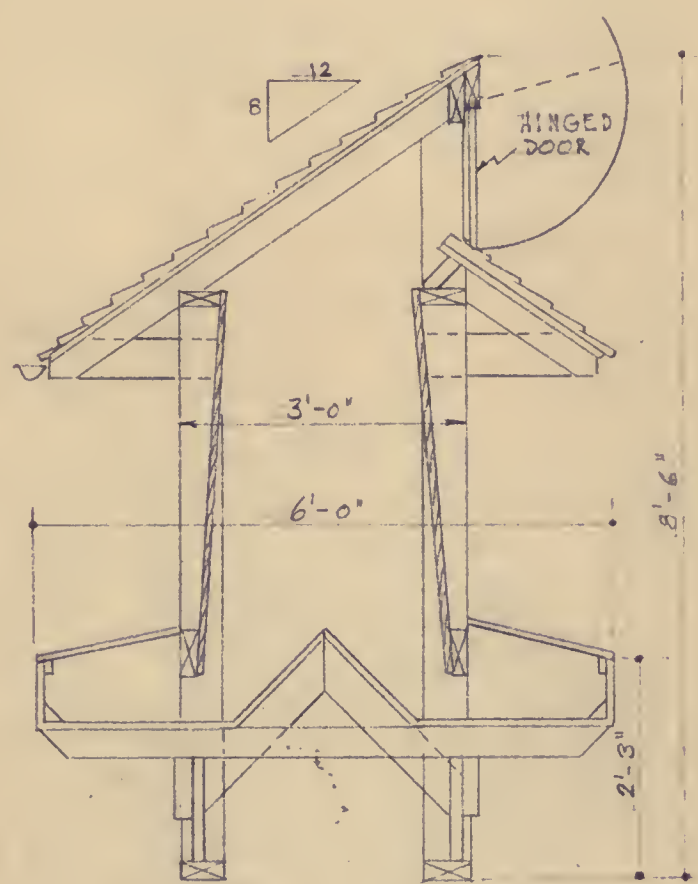

EXPLANATION OF PLATE XXXVII

An isometric view of pole type chopped hay storage,
drying, and self-feeding structure.

PLATE XXXVII

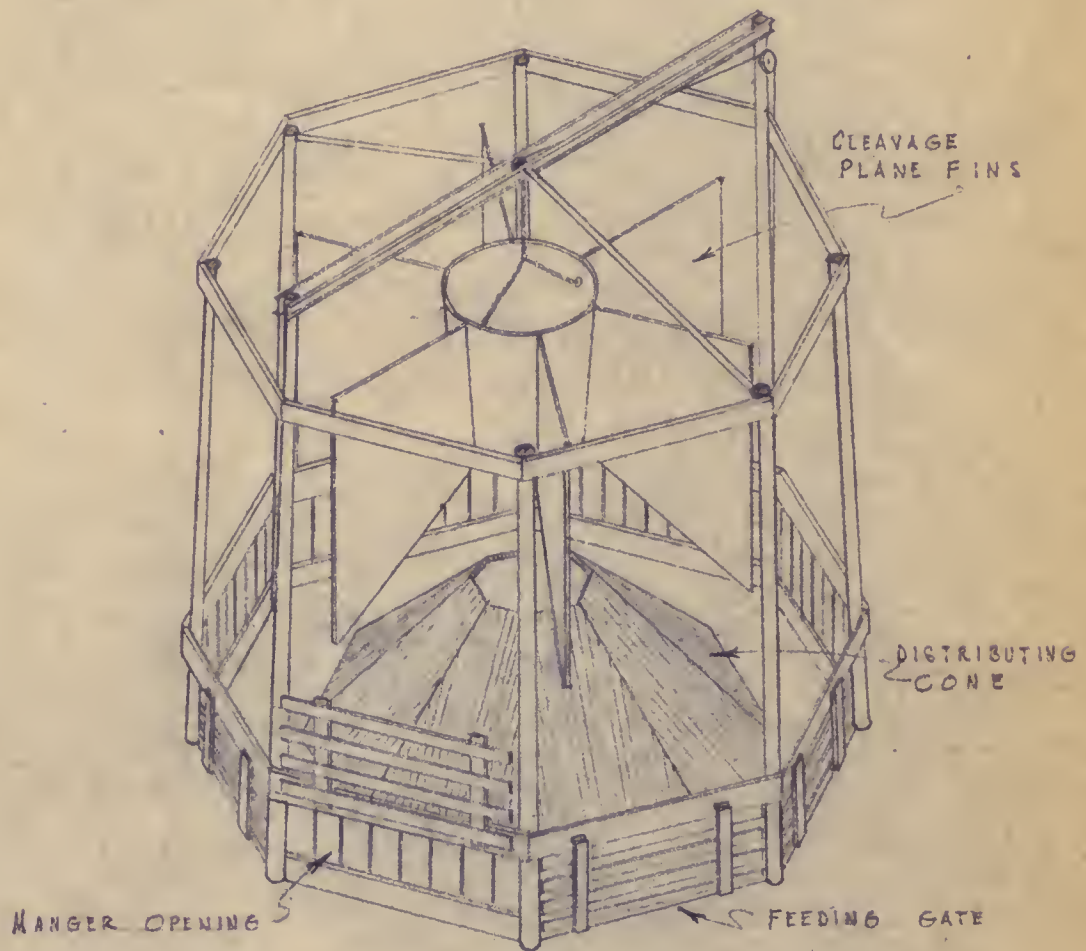

NOTE: SNOW FENCE SIDING
REMOVED TO SHOW INTERIOR

and design of farm built feeders. The designers of the structure shown in Plate XXXVII Shove et al., (15) list the following as essential construction requirements.

1. Taper the sides of the structure so the top diameter is smaller than the bottom diameter.
2. Install a cone in the center of the bottom to force the hay out to the feeder manger.
3. Use a swinging guard for the manger which will permit the cattle to reach well into the structure.
4. Form an unlined duct or core in the center of the structure.
5. Provide divider strips for the hay when filling so cleavage planes will be formed which will allow the hay to spread over the cone.

Self-feeders for Silage. Silage self-feeders discussed at this time include only those systems where the cattle eat the silage directly from the silo. At present most of these feeders are used in trench or bunker type silos. Non-mechanical unloaders in use on upright silos are not common at the present time. The users of silage self-feeding are finding this to be a very satisfactory system. Various reports indicate a labor saving of 80 to 90 percent over conventional hand feeding methods. The general opinion among livestockmen is self-feeding will work best for the small to medium sized operator handling beef calves, yearlings, or dairy cows. The beef cow may eat too much silage with self-feeding to be economical and the large operator may find it difficult to provide adequate feeder space.

The requirements of a trench or bunker silo used for self-feeding are: stabilized wall, a weather proof floor, adequate drainage, sufficient width for feeder space, and a suitable feeding panel. Plates XXXVIII, XXIX and XL

EXPLANATION OF PLATE XXXVIII

Isometric of typical skid mounted feeding fence for bunker silo with pipe divider.

PLATE XXXVIII

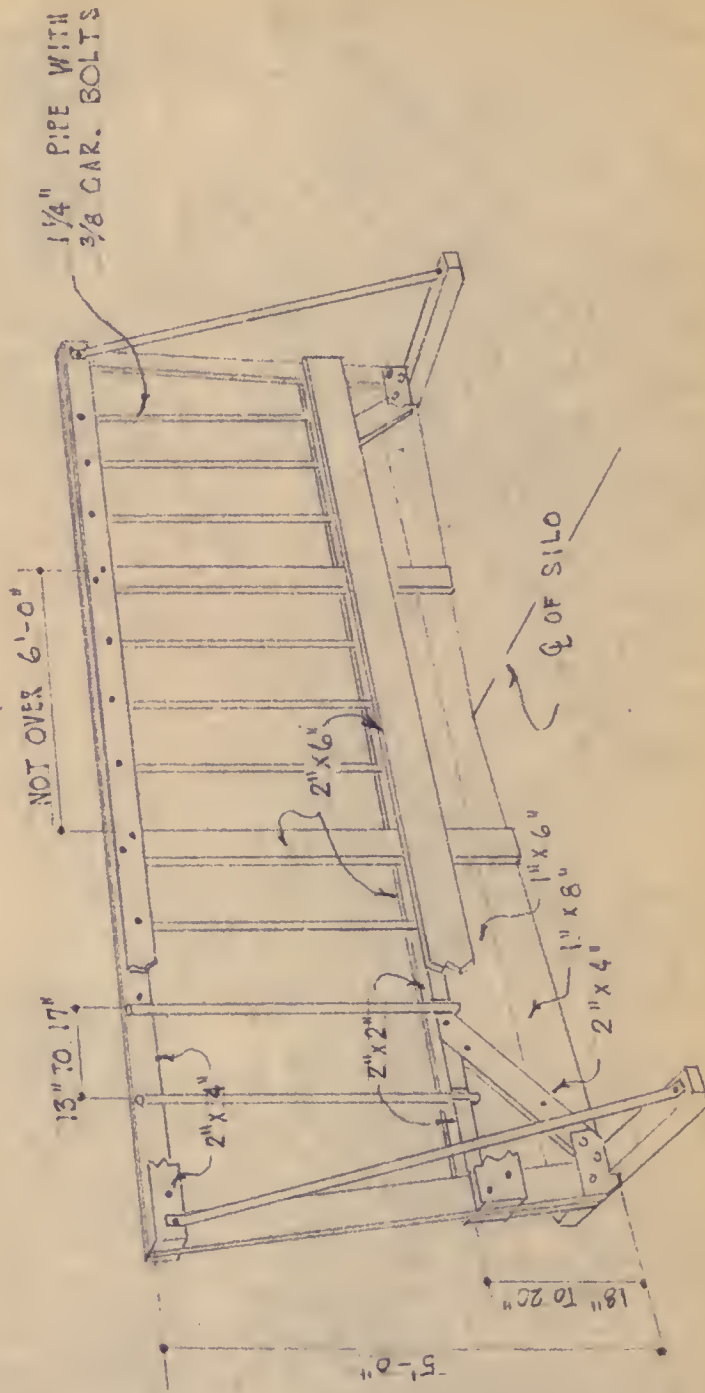

EXPLANATION OF PLATE XXXIX

Isometric of skid mounted feeding fence for bunker silo using "V"-notch feeding spaces.

PLATE XXXIX

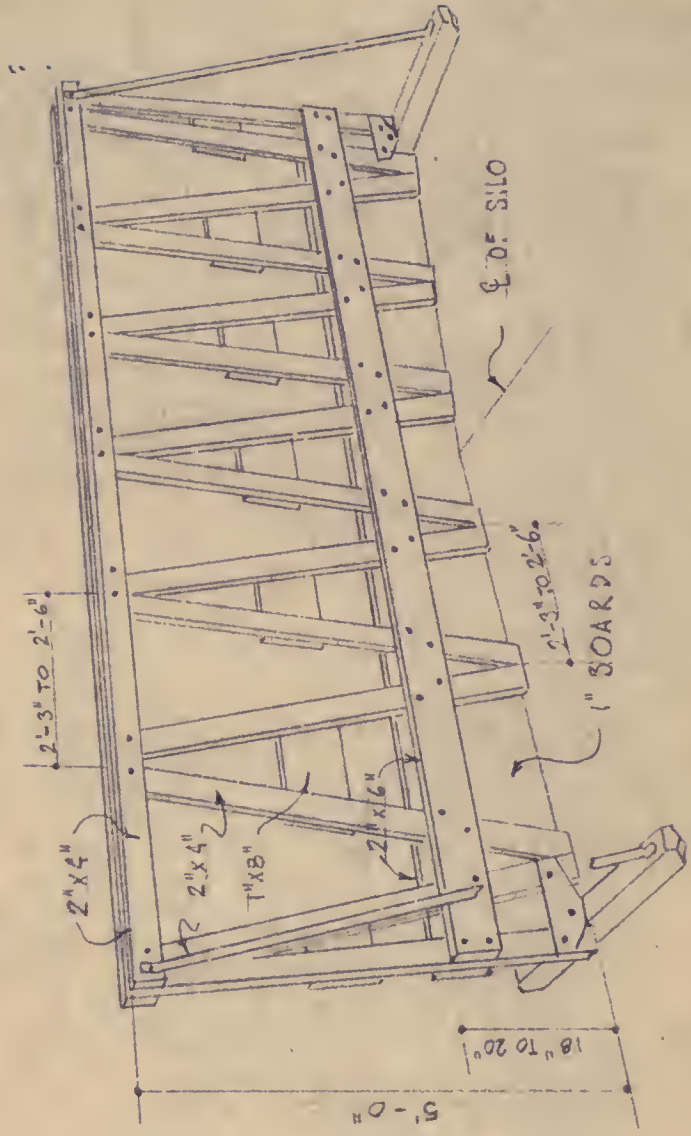

EXPLANATION OF PLATE XL

Isometric of swinging gate type self-feeding gate for bunker silo with
vertical lumber dividers.

PLATE XL

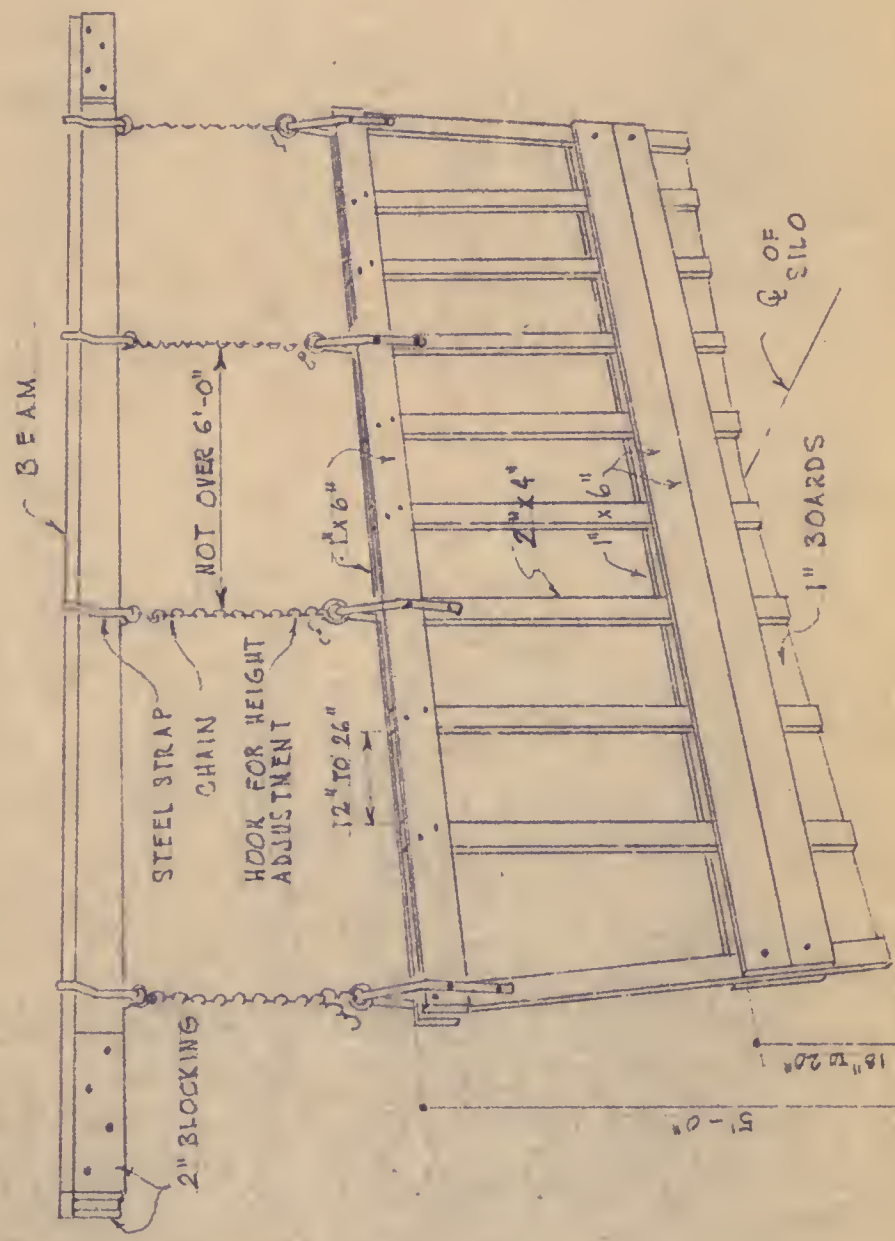

1

illustrate several variations in the self-feeding gates. Generally recommended features of the gate are: use vertical dividers for stalls, use solid fencing on the bottom 14 to 18 inches to prevent waste, and provide stops which will keep the panel at least 12 inches from the silage face at the bottom. The panel may be either skid mounted or supported from a beam across the top of the silo. The recommended feeder space requirement varies from three to six inches per head, three to four inches being adequate for calves and yearlings and six inches for mature cows. A floor slope of two feet per 100 feet of length is recommended. This provides good drainage and keeps water from flowing back under the silage. The periodical removal of manure from the silo is needed to insure good drainage. Storage over approximately seven feet in height will have to be hand fed as the cattle can not reach the higher feed.

Methods of Distributing Feed

The methods of distributing feed is discussed at this point as the fourth item of consideration in the automaton of a feeding system. The material to be covered concerns the application of various mechanisms to the job of getting feed placed in the feeders. A study of the mechanics of feed handling will be discussed in a later section. The development of new machines in recent years and the availability of high-line electrical power on the farm has revolutionized the opportunities in this field. The selection of a feed distributing system on any farm involves a wide range of choices. These choices require careful consideration of such factors as available equipment, feed storage method, location of feed, labor supply, the number of animals to be fed, and the productive use of saved labor. The following are general

recommendations regarding the use of common distributing equipment as determined by VanArsdall and Cleaver (18).

Wheeled Cart and Track Carriers. Wheeled carts or track carriers can provide effective and inexpensive methods of moving grain or silage from storage to feeder when the feeding area is adjacent to the storage. The system is most efficient when one load is adequate for one feedings. This method is best adapted to small and medium sized units or herds of from 20 to 100 head. They can, however, be used for larger units if power is employed to move the carriers. These feeders operate best when bunks are placed in straight continuous rows. Arrange the system so the feeding can be done by walking in the feed bunk. The installation of a self-dumping hopper bottom in the carrier will eliminate the need for scooping to unload the carrier. A study on six farms using this method of distribution silage indicated that the average cost of equipment for handling feed by this method was approximately fifteen cents per ton.

Wagon. The tractor drawn wagon provides an economical feed distributing system adapted to use where the feed must be hauled from the storage point to the feeders. The system requires very little special equipment but the physical labor of unloading is not eliminated. The wagon system can be used on most any size operation. The best bunk arrangement for this method of feeding is the fence line feeder illustrated in Plate XXV. When in the corral, arranging the feeders in rows eliminates the need for making sharp turns and if easy to operate gates are provided the feeding operation will be more efficient. Under ideal conditions it is possible to feed about twice as much feed with a wagon in a given time as with a carrier. The study cited (18) found the power and equipment costs by this method averaged thirty-two cents

per ton of feed handled. The average rate of feeding by wagon on 16 farms was 30 minutes per ton of feed.

Self-unloading Wagon. These wagons may be either truck or tractor powered. They are definite time and labor savers. No physical labor is needed to unload the wagon and the time required for feeding by this method is about half that of a wagon system. The high investment in the wagon requires a medium to large operation to justify the cost. This method is best suited to operations where the feed is stored out of the lots and feeding is along a feeding fence and road. For operations of approximately 200 head the cost of machinery and power averaged 41 cents per ton in four cases studied (18). Such a cost can, however, be justified on the labor saved and the hard work eliminated. A few features generally desired on feeding wagons include; ability to handle both grain and silage or a mixture of these feeds, cross-conveyor to bunks located at front of the bed for easier control, simple efficient power mechanism. Plates XLI and XLII are photographs which illustrate the use of these features on a farm built feeding wagon constructed by Mr. Gene Lorson of Abilene, Kansas. Numerous livestockmen are building such self-unloading wagons as a means of providing the equipment at a lower cost. If properly designed and built they are very satisfactory.

Power Scoop Feeding. The power scoop or front end loader provides an effective tool for feeding silage from a horizontal, trench, or bunker silo when the silo is located near the feeding area. The use of this method is most efficient when the feeders are within 60 feet of the silo. Placing a series of box type feeders along a fence as illustrated in Fig. 2, Plate XXXIII is recommended for this system. Each of these feeders will accommodate from 10 to 15 head of cattle. This type of feeder is easier to fill with a

EXPLANATION OF PLATE XLI

Fig. 1. Home-made self-unloading wagon on two wheel trailer with power take-off drive and auger cross conveyor. Built by Mr. Gene Lorson Abilene, Kansas.

Fig. 2. Close-up of drive mechanism for self-unloading wagon.

PLATE XLI

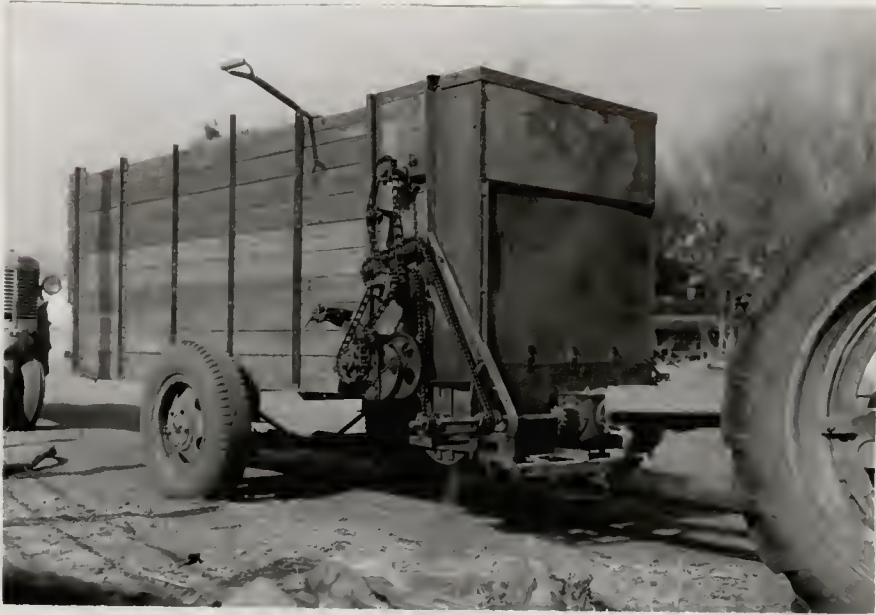

Fig. 1

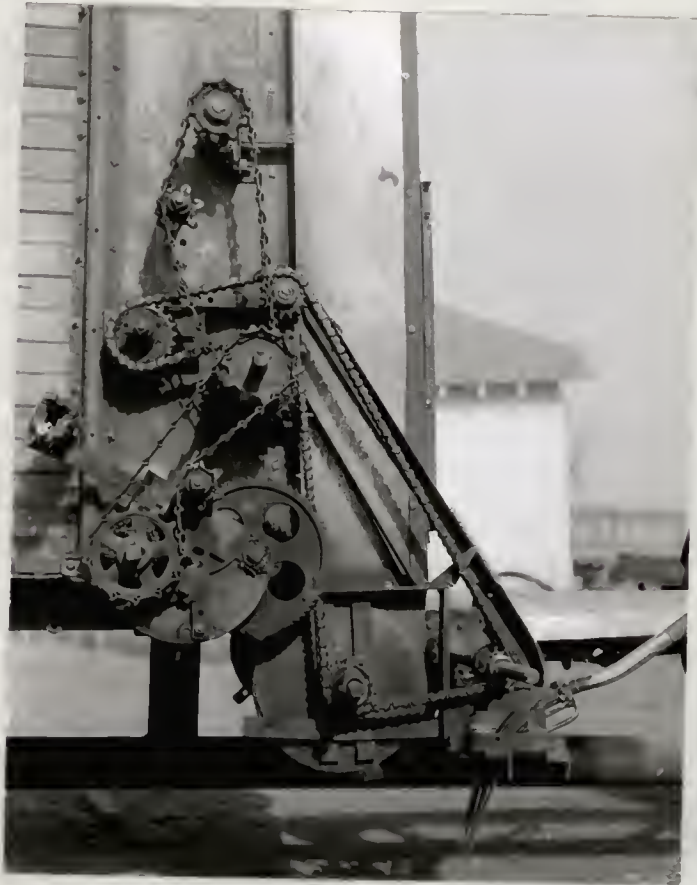

Fig. 2

EXPLANATION OF PLATE XLII

Fig. 1. Home-made self-unloading wagon with chain conveyor
for cross drive elevating.

Fig. 2. Close-up of drive mechanism for self-unloading wagon.

PLATE XLII



Fig. 1



Fig. 2

scoop without spilling feed. The estimated power and equipment cost for feeding by this method ranges from 15 to 20 cents per ton of silage handled. The power scoop method of feeding can be used on units of all sizes with little change in efficiency since the equipment is used for other jobs on the farm.

Bunk Line Conveyors. The installation of powered conveyors of various types in the feeding bunk proper provides an additional method of distributing feed. Conveying equipment in use for the method include drag conveyors, auger conveyors, and shuttle-stroke conveyors. The use of this equipment is limited to permanently arranged feeding bunks placed in a line and located adjacent to the feed storage. These conveyors eliminate nearly all of the hand labor required for placing feed in the bunks. The power required to operate these systems varies with the type used and the length of the conveyor. The range being from three-fourths to three horse-power. Plates XLIII, XLIV, XLV, and XLVI illustrate the different conveying systems.

FEED HANDLING

The last section on feed handling considers the problem of automaton in feed movement. The characteristics of the various conveying methods are presented and their application to livestock feeding is discussed. The related subjects of feed storage and processing are omitted as a just treatment of these subjects would require separate complete studies. Some of the information presented can, however, be applied to problems of feed processing and grain storage. The use of adapted feed conveying methods will reduce the time required for feed handling, decrease the back breaking work in livestock production, and encourage better feeding practices. These efficiencies can

EXPLANATION OF PLATE XLIII

Isometric of wheeled cart bunk line carriers with dump bottom.

PLATE XLIII

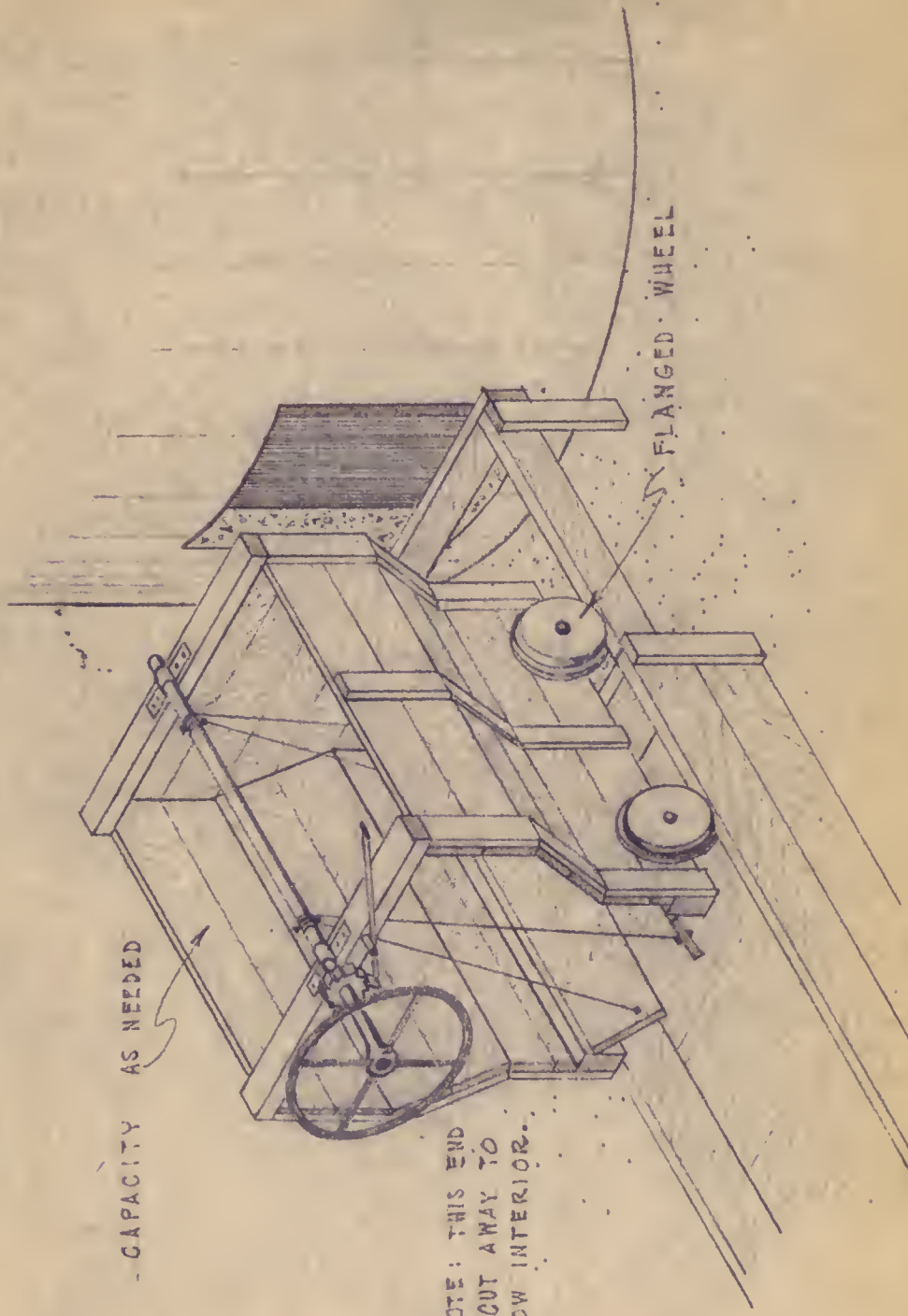

CAPACITY AS NEEDED

FLANGED WHEEL

NOTE: THIS END IS CUT AWAY TO SHOW INTERIOR.

EXPLANATION OF PLATE XLIV

Isometric sketch of a slat drag-chain conveyor. Normal conveyor speed three to five feet per minute. Power required for 100 feet of length $3/4$ horse-power.

PLATE XLIV

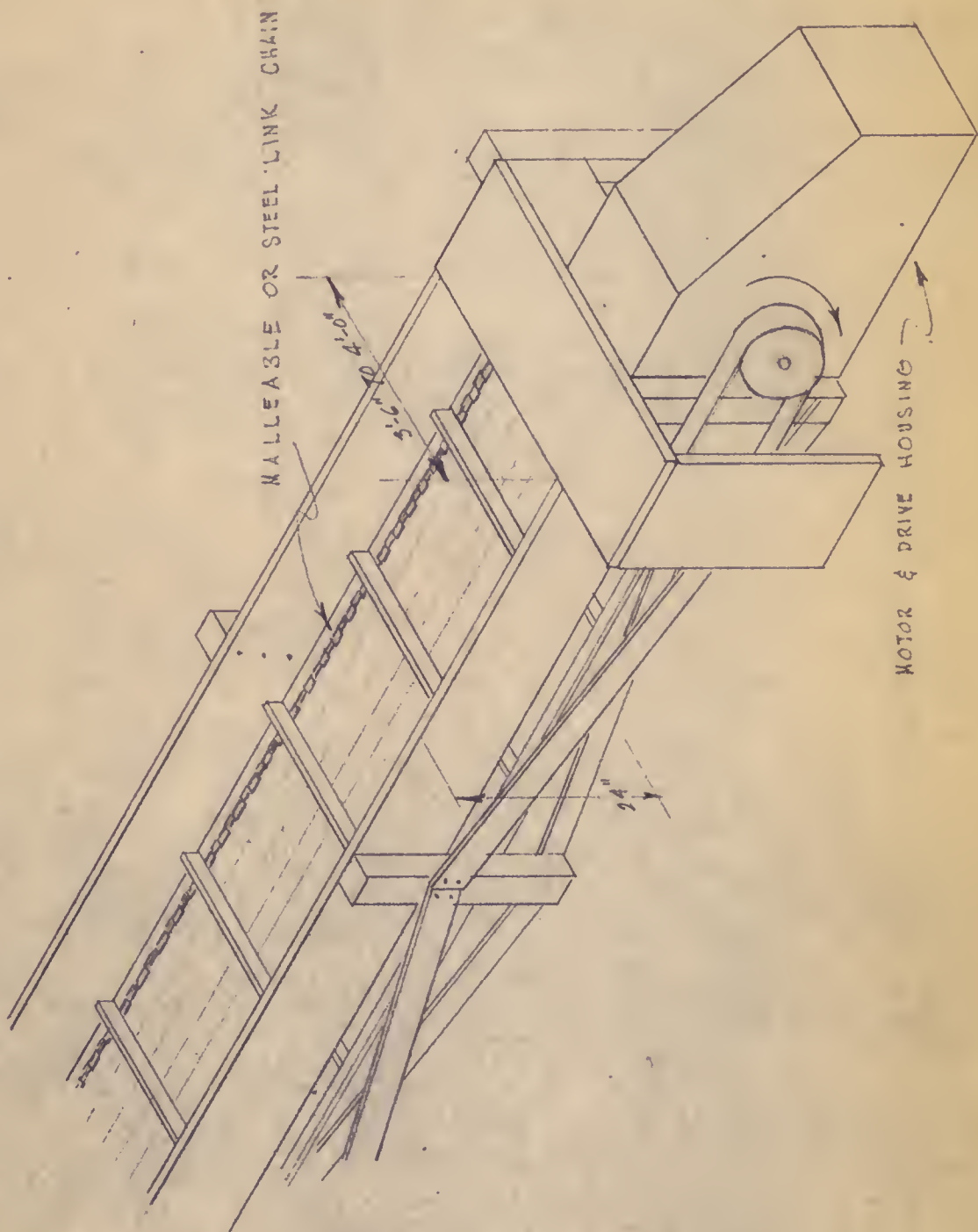

EXPLANATION OF PLATE XLV

Isometric sketch of auger bunk conveyor-power requirement approximately two horsepower per 100 feet of length.

PLATE XLV

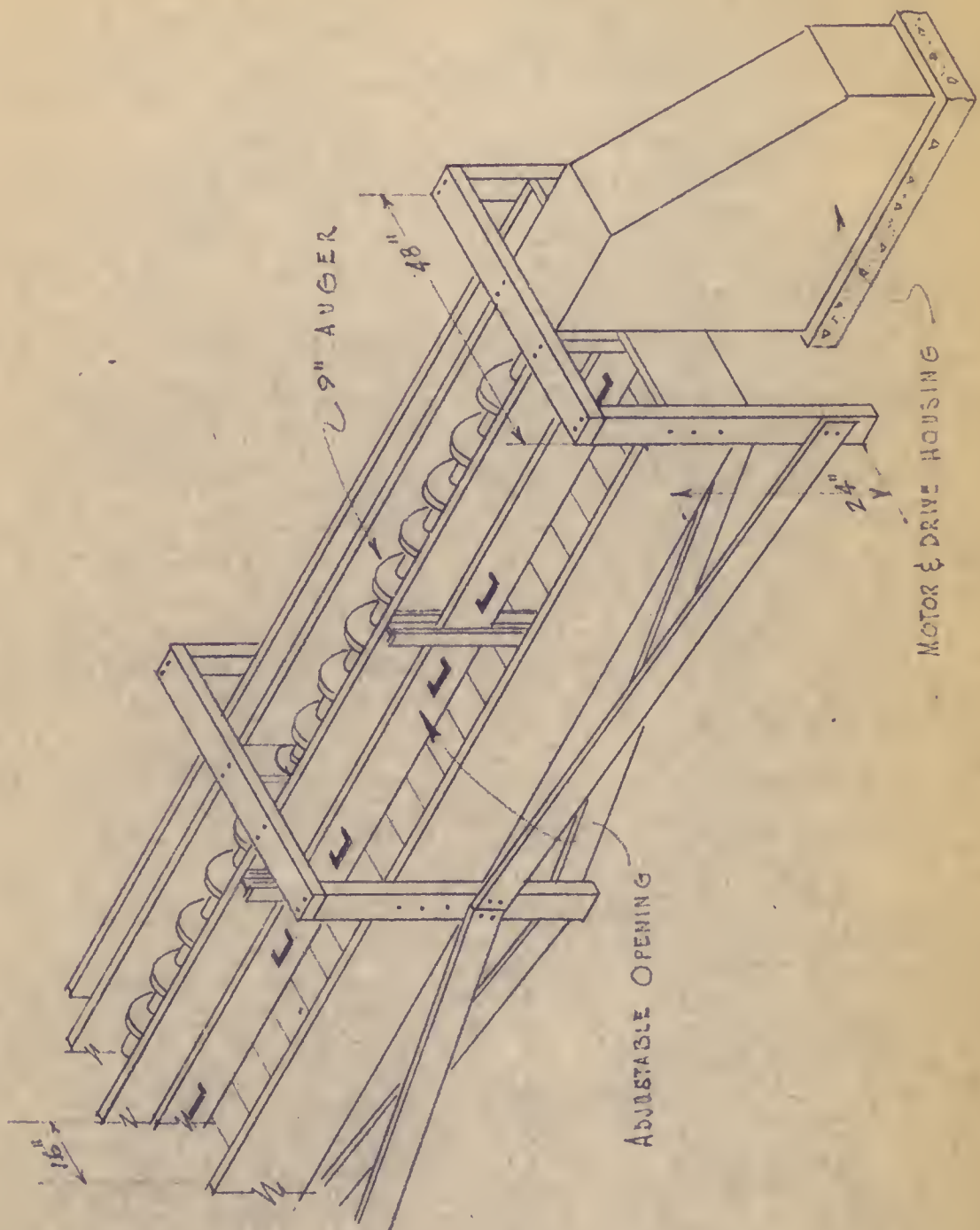

EXPLANATION OF PLATE XLVI

Fig. 1. Cross-section of bunk with Jamesway shuttle stroke conveyor above the bunk.

Fig. 2. Cross-section of Jamesway shuttle stroke conveyor in feed bunk.

PLATE XLVI

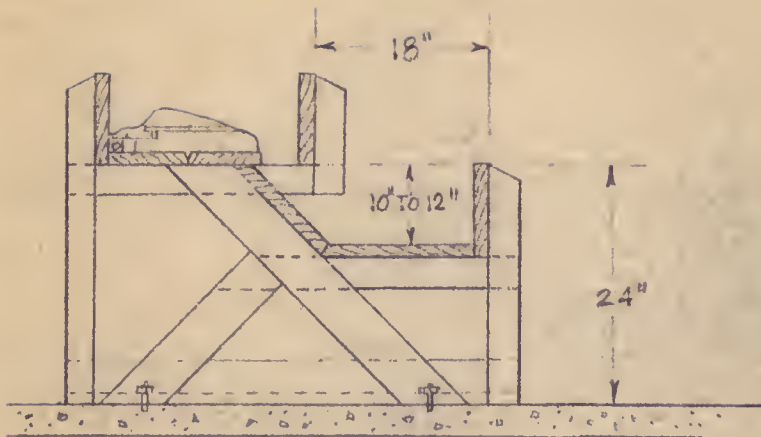

FIG. 1

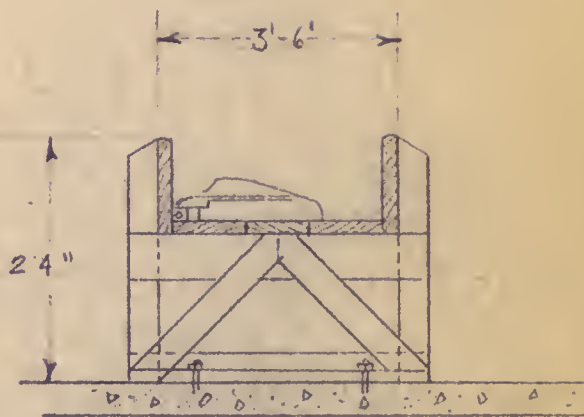

FIG. 2

be accomplished by installing conveying equipment to load, unload, transport, and distribute the various livestock feeds. The major types of conveying equipment suitable for livestock feed movement are:

1. Hopper bottom bins.
2. Belt conveyors.
3. Chain conveyors.
4. Screw conveyors.
5. Bucket elevators.
6. Pneumatic conveyors.

Each of these conveying methods has distinct advantages, disadvantages, and limitations which should govern the selection, construction, and use of the equipment for a feed handling system.

Hopper-bottom Bins

The hopper-bottom bin represents a non-mechanical method of conveying feeds. This method of moving feeds requires no additional power. It is simple to operate and has a wide flow range with easy control. The structure provides an efficient method of loading wagons, trucks, or carts and can be used as a continuous flow self-feeding device for processing equipment such as grinders. These bins also have many other self-feeding applications. Hopper-bottom bins can be used for all livestock feeds but are best suited to grains. Chopped roughages present a more difficult flow problem than grains since they tend to bridge or cling together. The limited distance of horizontal movement possible by this method prevents a more general use of this conveyor.

The minimum recommended floor slopes are 45 degrees from horizontal for whole grains and 60 degrees for ground feeds. These slopes are sufficient for self-cleaning on most feeds provided the floor surface is smooth. In extreme cases it may be necessary to install an agitator or vibrator to insure free flow.

The disadvantages most commonly listed for this conveying method are: the loss of storage space due to the hopper-bottom, the height of storage required to permit gravity flow, and the additional construction work required to erect the bin.

The metal grain bins from some old discarded pull-type combines are being used for the hopper-bottom section of bins in some cases. Their use simplifies construction and reduces the cost in most cases. Such bins can be placed over driveways and in hay mows quite easily. Their capacity is often increased by adding to the bin side height. The capacity of a grain bin in bushels can be determined by multiplying the volume in cubic feet by eight-tenths. The volume of a rectangular bin in cubic feet can be calculated by multiplying the length times the width times the height. A convenient minimum size for these bins is sufficient capacity for one load or batch as required in the program.

Belt Conveyors

The belt conveyor is essentially an endless belt operating between two or more pulleys. This type of conveyor can be used in livestock feed handling to move feeds horizontally from storage to processing and from processing to feeder. This conveyor is also used in some self-unloading and loading equipment. Belt conveyors have high mechanical efficiencies. They

inflict a minimum of damage to the feeds being moved. They have relatively high capacities, and when properly designed and maintained they give many years of service. Belt conveyors are excellent for moving feeds long distances in one direction horizontally. Fine free flowing granular materials tend to blow or shake off high speed flat belt conveyors. The use of a trough-shaped belt or providing a box frame for the belt to travel in will reduce this problem.

The factors governing the use of belt conveyors are the high initial cost and the limited amount of elevation possible. The maximum recommended incline for conveying grain by belt is 20 degrees.

The parts of a belt conveying system consist of belt, drive, tension or take-up, idlers, and loading and unloading devices. Belting materials commonly used include stitched canvas, solid woven balata, and rubber. The canvas and woven belts are normally impregnated with a water proofing material. The balata belts are similar to rubber belts in wearing qualities for livestock feed handling purposes. The size and type of belting to select is determined by the materials to be handled and the rate of flow desired.

The drive should be at the discharge end of the belt. It can be any conventional belt drive. The pulley must be large enough to insure positive belt movement and prevent over flexing the belt. If additional driving pulley surface contact is required an idler pulley can be used to provide a greater arc of contact. The take-up feature is necessary in order to take care of belt stretch or contraction and expansion due to changes in moisture and temperature. This take-up can be adjusted manually by means of adjusting screws on the end pulley or operated automatically by means of a weighted

idler pulley. To prevent excessive drag and wear on long belts load-carrying idlers are installed periodically along the conveyors length. These may be either flat single or multiple pulleys. The multiple pulley permits a trough-shaped belt which has a larger carrying capacity.

The loading of a belt conveyor should be by constant continuous flow. The hopper-bottom bin or some other conveyor are excellent although hand feeding can be used. The unloading will normally be over the end of the belt. It can, however, take place anywhere along the line. Methods for discharging along the line include: using a diagonal scraper, a tripper, or by tilting the belt with idlers.

The recommended belt speed will vary with the material handled and the width of the conveyor belt. The following are maximum recommended belt speeds in feet per minute for handling livestock feeds as reported by Knight and Dixon, (10).

1. Grain --- 400 to 800 feet per minute.
2. Chopped hay --- 220 to 250 feet per minute.
3. Sacked materials --- 120 to 300 feet per minute.
4. Dry sawdust --- 400 to 800 feet per minute.
5. Silage --- 400 to 800 feet per minute.

Slower speeds may be used if desired. There is no recommended minimum.

The power requirements for belt conveyor operation can be calculated reasonably close from the following empirical data secured from the Link-Belt Company by Henderson and Perry, (7).

1. Horsepower to drive empty conveyor

$$= \text{Belt speed, feet per minute } (A + BL) / 100$$

L = conveyor length in feet.

A = constant, see table 1.

B = constant, see table 1.

Table 1. Conveyor belt constants.

Conveyor Belt Width, in.	Constant A	Constant B
14	0.20	0.00140
16	0.25	0.00140
18	0.30	0.00162
20	0.30	0.00187
24	0.36	0.00224
30	0.48	0.00298
36	0.64	0.00396
42	0.72	0.00458
48	0.88	0.00538
54	1.00	0.00620
60	1.05	0.00765

2. Horsepower to convey material on level

$$= \text{Tons material per hour, } (0.48 + 0.00302L) / 100$$
3. Horsepower to lift material

$$= \text{Lift in feet} \times 1.015 \times \text{Tons of material per hour} / 1000$$

The total power required is the sum of the power requirements calculated from equations. 1, 2, and 3.

Belt conveyors require careful engineering in design and construction to function properly. It is therefore advisable to secure the services of an engineer when installing this type of conveyor if a sizable unit is needed.

Chain Conveyors

Chain conveyors provide one of the most versatile methods of moving livestock feeds. The system consists of one or two chains with flights operating in a wooden or steel trough. The chain conveyor is simple to design, easy to build, economical to construct, and is adapted to moving all livestock feeds. They are not as mechanically efficient, fast, or quiet as the belt conveyor. Two types of chain conveyors are commonly used to handle feeds. They are scraper conveyors and apron conveyors. The scraper being adapted to

use for grains, using flights and the apron being adapted to the movement of roughages such as silage, hay, and sacked materials. The apron conveyor utilizes flat slats as a conveying device.

The construction and design of both the scraper and apron conveyors are so similar only the scraper conveyor will be discussed in detail. The chain used can be any one of several types and the choice depends on the service required. The malleable detachable chain is most common and economical. This chain will provide excellent service for light loads and where only intermittent service is required. A chain with approximately the same strength but with better wearing qualities is the pintle malleable. This chain is commonly used inside elevators and other similar places. Where both high strength and long wearing qualities are needed the steel and roller chains are recommended.

The flight height, length, and spacing depends on the expected duty of the conveyor. In general flat flights are recommended for sacked materials or baled hay, shallow flights for large sized materials such as ear corn and standard flights for small grains or ground feeds. The standard flight height is approximately four-tenths the flight length and the spacing is approximately the flight length. The length will be just slightly less than the trough width.

The normal speed for chain conveyors varies from 75 to 125 feet per minute. The slower speeds are for larger materials and the faster speeds are for small grains. The speed may however be reduced as desired. For example apron conveyors on unloading wagons will normally run from one and one-half to three feet per minute and bunk conveyors as illustrated in Plate XLIV operate at speeds of less than five feet per minute. It is normally better to increase the capacity of a chain conveyor by increasing the flight and

conveyor size rather than the speed. High speeds on this equipment causes excessive wear and may damage the product being conveyed.

The capacity of a scraper conveyor operated on the level can be assumed to be 115 percent of the rectangular space between flights when designed as outlined by Henderson and Perry, (7). This capacity is reduced when operating at an incline as indicated below.

Table 2. Effect of incline on conveyor capacity.

Incline Degrees	:	Approximate Relative Capacity
20		0.77
30		0.55
40		0.33

These capacities are based on movement in an upper side open top conveyor. If materials are in an inclosed lower side conveyor the incline will not materially affect the capacity. The inclosed type conveyor is normally used for incline conveying for this reason.

According to Henderson (7) the theoretical power requirement for flight chain conveyors can be determined from the following formula.

$$\text{Horsepower} = \frac{2vL_c W_c F_c + Q(LF_m + H)}{33,000}$$

- v = speed of conveyor, ft per min.
- L_c = horizontal projected length of conveyor, ft.
- W_c = weight of flights and chain, lb per ft.
- F_c = coefficient of friction for chains and flights.
- Q = lb material to be handled per min.
- L = horizontal projected length of loaded conveyor, ft.
- F_m = coefficient of friction for material.
- H = height of lift, ft.

Table 3. Friction Coefficients (Sliding).

Material	:	Coefficient	:	Source
Metal on oak		0.50-0.60		Marks
Oak on oak, parallel fibers		0.48		Marks

Table 3 (cont.)

Material	Coefficients	Source
Oak on Oak, cross fibers	0.32	Marks
Cast iron on mild steel	0.23	Marks
Mild steel on mild steel	0.57	Marks
Grain on rough board	0.30-0.45	Ketchum
Grain on smooth board	0.30-0.35	Ketchum
Grain on iron	0.35-0.40	Ketchum
Coal on metal	0.60	Link-Belt
Dry sand on metal	0.60	Link-Belt
Malleable roller chain on steel	0.55	Badger and McCabe
Roller-bushed chains on steel	0.20	Badger and McCabe

The theoretical horsepower as calculated from the above formula should be increased from 70 to 100 percent in practice to provide a suitable safety factor for inefficiencies. (Table 8 appendix) gives the size of electrical motor required to operate flight type chain conveyors of different lengths at a constant conveying rate and incline.

Screw Conveyors

The auger or screw conveyors are well suited to many livestock feed handling operations. They are used to handle small grains, ground feeds, sticky feeds such as molasses, and roughages such as chopped or ground hay and silage. This type of conveyor can be used to convey, mix, and meter feeds. The units may be used to move feeds horizontally at an incline or vertically. The auger can be either portable or permanently located. They may operate independently or as a part of a machine such as a self-unloading wagon. The screw conveyors are simple relatively inexpensive machines.

The disadvantages of this conveyor are: a high power requirement, and limited length of single sections. The auger may damage some small grains by cracking. Cracking of small grains can be reduced by providing the proper clearance between the screw and the case. The clearance should be approximately

two and one-half times the diameter of the seed Knight and Dixon, (10).

The size and type of screw to select should be determined by the material to be handled, the desired rate of flow, and the degree of conveying incline. The standard pitch screw will normally be used for horizontal and inclines up to 20 degrees. Half standard pitch screws are used on steeper inclines. Double and triple-flight, variable-pitch, and stepped-diameter screws are used for moving difficult materials and for controlled feed rate work. Ribbon screws are used for wet or sticky substances and mixing.

A concise accurate formula for determining the capacity of a screw is not available. The best source of data on the capacity of an auger can be obtained from the manufacturer. A rough estimate of a screw's capacity can be determined by using the following formula Henderson and Perry, (7).

$$\text{Theoretical capacity, cu ft per hr} = \frac{(D^2 - d^2)}{36.6} \times P \times \text{rpm}$$

- D = screw diameter, in.
- d = shaft diameter, in.
- P = screw pitch, in. (normally equal to D).
- rpm = revolutions per minute of shaft.

The actual capacity will be from 50 to 60 percent of the theoretical capacity.

An approximate power requirement for normal horizontal operation of a screw conveyor can be determined from the following equation Henderson and Perry, (7).

$$\text{Horsepower} = \text{CLWF} / 33,000$$

- C = conveyor capacity, cu ft per min.
- L = conveyor length, ft.
- W = bulk material weight, lb per cu ft.
- F = material factor, (see Table 4)

Table 4. Material classification and indices for screw conveyors

Material	Bulk Weight lb per cu ft.	Horsepower Material Factor, F
Barley	38	0.4
Beans	48	0.4
Beans, castor	36	0.5
Beans, soy	45-50	0.5
Bran	16	0.4
Butter	59	0.4
Corn, shelled	45	0.4
Cornmeal	40	0.4
Cotton seed (dry)	25	0.9
Cotton seed hulls	12	0.9
Line, ground	60	0.6
Milk, dried	36	1.0
Oats	26	0.4
Peanuts, unshelled	15-20	0.7
Rice, clean	45-48	0.4
Rye	44	0.4
Sawdust	13	0.7
Wheat	48	0.4

When using the above formula to determine horsepower make the following adjustments from theoretical.

Table 5. Screw conveyor horsepower correction factor

Calculated Horsepower	Factor
less than 1 multiply by	2
1 to 2 multiply by	1.50
2 to 4 multiply by	1.25
4 to 5 multiply by	1.10
5 and over no correction.	1.00

For more information on the capacity, speed and motor size for screw conveyors refer to (Tables 10, 11, and 12 appendix)

Bucket Elevators

The bucket elevators are special adaptations of either belt or chain conveyors. In the field of livestock feed movement they are well suited to

the vertical or near vertical movement of small grains or ground feeds. Bucket elevators are quite efficient and somewhat more expensive to install than standard chain conveyors. The higher efficiency is due to the absence of friction losses from sliding materials on the housing. These elevators may be built of the size and capacity needed.

The bucket elevator may be built with both elevating and returning buckets in a single housing or the two may be in separate housings forming a two leg elevator. The return in this case can be some distance from the elevating leg if desired. The buckets are normally fastened to the chain or belt at the back. When chains are used either a one or two chain system can be installed. The two chain system is normally used for the larger units. The complete elevator is made up of the following parts: the chain or belt, buckets, head drive, foot drive, and guides or idlers in an inclosed housing. Guides are used with the two chain elevator and idlers for belt and one chain units. The purpose of the guide or idler is to prevent whip in the leg.

The power should be applied at the head pulley and the take-up for chain-wear or belt-tension provided by moving the foot pulley. The speed of operation is very important for satisfactory performance in loading and discharging feed from the buckets. The size of the head wheel will normally determine the speed. The following equation according to Henderson and Perry, (7) gives the relationship between the effective head-wheel radius and its speed in revolutions per minute for most satisfactory discharge.

$$N = 54.19 (1/\sqrt{r})$$

N = revolutions per minutes

r = effective head-wheel radius.

The foot wheel will normally be about the same diameter as the head wheel. When this condition exists loading should be satisfactory. If a smaller foot wheel is used it may be necessary to reduce the speed to secure adequate filling. By delivering the feed directly to the elevator buckets at a point slightly above the foot wheel full loading is obtained and overloading the boot in case of trouble is greatly reduced. The buckets are normally spaced on the chain or belts from two to three times the projected width apart.

The theoretical power required to elevate feed by bucket elevator Henderson and Perry, (7) can be calculated from the following equation.

$$\text{Horsepower} = \frac{QH}{33,000}$$

Q = amount of material handled per minute, lb.

H = belt speed in feet per minute times number of buckets per foot times capacity of buckets in pounds.

H = lift, ft.

This calculated horsepower should be increased from ten to 15 percent when selecting a power unit. For more information on power required for bucket elevators consult (Table 9 appendix).

Pneumatic Conveyors

The pneumatic conveyor can be used to convey such livestock feeds as chopped hay or grains in either a horizontal or vertical direction. The advantages of the pneumatic conveyor are: relatively low initial cost, mechanically simple, easy to change conveying path direction, conveying path may have branches, will handle a wide variety of feeds, and the system is self-cleaning. The disadvantages to the system are: high power requirements, possible damage to conveyed materials, and technical engineering data should be secured for installation.

The type of pneumatic conveying equipment to install should be determined by the material to be handled. There are three systems of pneumatic conveying in use for the handling of feeds.

1. Suction systems which operate below atmospheric pressure. This system is best for unloading materials where the point of unloading may move. This method is suited to materials such as hay that will not readily pass through valves, screws, or fans.
2. Low-pressure systems which use high velocity low-density air. This system normally uses a centrifugal fan and operates at low to moderate pressures. Systems using pressures not exceeding fourteen inches of water are considered low-pressure system.
3. High-pressure systems using low-velocity high-density air. This system normally uses a positive displacement blower. In general the pressure systems are more efficient than the suction system.

Materials may enter the pneumatic conveying system by being introduced directly into the fan, sucked up by a flexible hose, or metered into the moving air stream by a bucket elevator, screw conveyor or column feeder.

The generally accepted material conveying rate is 50 feet per second. This requires an air velocity sufficient to support the particles of material being conveyed plus 50 feet per second. The air velocities required to accomplish this for the common feeds are listed by Knight and Dixon, (10) as follows:

Grain -----4000 to 5000 feet per minute.

Chopped Hay-6000 to 8000 feet per minute.

Silage -----4200 to 7100 fan tip speed in feet per minute depending on height of elevation.

Under low-pressure system operation one pound of materials can be handled by each 35 to 50 cubic feet of air. The minimum air-grain ratio for grain on a high pressure system is approximately five cubic feet of air per pound of grain.

The following summary of conclusions regarding the use of pneumatic conveyors for grain movement was made by Kleis (9) after conducting a series of studies on the subject.

1. A conveying air velocity of 4,000 feet per minute is necessary and sufficient for satisfactory and continuous operation.
2. The optimum pipe diameter for any pneumatic system is the smallest allowable for the desired conveying rate. The practical limits of conveying rates for common pipe sizes at a velocity of 4,000 feet per minute are:

4-inch-pipe: 3,500 pounds per hour
 5-inch-pipe: 4,500 pounds per hour
 6-inch-pipe: 6,500 pounds per hour

3. The optimum pipe diameter for a pneumatic conveyor is not affected by the length of the system.
4. The power required to maintain an air velocity of 4,000 feet per minute without grain flowing in the system approximates:

1 horsepower for each 100 feet of equivalent length of 4-inch pipe.
 $1\frac{1}{4}$ horsepower for each 100 feet of equivalent length of 5-inch pipe.
 $1\frac{1}{2}$ horsepower for each 100 feet of equivalent length of 6-inch pipe.

When grain is injected into the system, the power requirement is increased by about one-third horsepower for each 1,000 pounds of grain per hour.

5. Neither previous work nor the results of this study indicate any efficiency advantage to sloping the conveyor pipe in one direction or another. To facilitate drainage of moisture, however, the pipe should slope slightly toward the discharge end.
6. The arrangement of the pipe in a conveyor system should be such that no elbow is within about 20 pipe diameters of the dust collector.
7. Heavier grains as well as coarsely ground feed require slightly more horsepower for a given conveying rate than grains that are lighter or finely ground. These differences, however, are negligible so far as the design of a pneumatic system is concerned.
8. A considerable amount of reduction in particle size occurs when ground feed is run through a blower. This might well be considered in determining how fine to grind grain.

9. A considerable amount of separation occurs according to particle size at the discharge point of any type of conveyor. This separation is slightly greater with a pneumatic-type conveyor than with an auger or belt-type conveyor, but the difference among them is extremely small compared with the total separation in all three types of systems.

10. Pneumatic conveyors are considerably less efficient than mechanical conveyors so far as power requirement is concerned. In other respects, however, the advantages of pneumatic conveyors are such that they constitute a practical solution to a great number of conveying problems.

For more data on power requirements, capacities and operating speeds of pneumatic conveyors see (Table 6 appendix).

The information in this section has clearly indicated conveying equipment can be efficiently and economically used to move the various livestock feeds. The selection of a system should be based on the individual's needs. The major items of consideration when selecting a system include: the type of feed, the amount to be handled, the distance of movement, the direction of movement, the rate of movement, and available capital. The information presented is somewhat general and incomplete, however, additional design information can be secured from the manufacturers of the conveying equipment and engineers.

CONCLUSIONS AND SUMMARY

1. The automaton of livestock handling and feeding can help the cattle producer in the following ways:
 - a. Reduce the labor required for handling and feeding.
 - b. Increase production income by promoting better management practices.
 - c. Increase production efficiency by reducing unnecessary losses such as wasted feed and injured animals.
2. The major areas of consideration in the automaton of a cattle program are: livestock handling, livestock feeding, and feed handling.

3. Successful automaton requires systematic planning.
 - a. Evaluate present practices and resources.
 - b. Determine requirements or needs.
 - c. Develop plans for a new or improved method.
 - d. Apply the new method.
4. Practical automaton demands convenience, safety, simplicity, and flexibility be the criterion for the design of cattle handling and feeding facilities.
5. The minimum requirements for a working corral design are:
 - a. Two holding pens inclosing an area of from 20 to 40 square feet per head to be handled at one time.
 - b. One crowding pen inclosing approximately 400 square feet.
 - c. One working chute approximately 30 inches wide and 25 to 30 feet long.
 - d. A loading chute and a squeeze chute or head gate.
 - e. The addition of scales, spray pen, cutting gates, and more pens will depend on the needs.
6. The automaton of livestock feeding can be accomplished by: mechanization, the use of new and better equipment, and a better arrangement of equipment and facilities.
7. A corral or feeding yard will normally consist of at least two pens with an inclosed area of from 150 to 300 square feet per head.
8. The most generally accepted size and space requirements for feeding racks and bunks are: feeding space, two lineal feet of feeder per head; throat height, 20 to 24 inches above ground level; feeder width, 24 to 30 inches for one side feeders, 42 to 48 inches when feeding is from both sides; feeder depth,

12 to 16 inches.

9. The more common methods of distributing feed include:

- a. Wheeled cart and track carrier is suited to medium or small operations, 20 to 100 head. Feeding by this method is direct from storage to feeder.
- b. Wagons hand unloaded are suited to any size operation where feed must be hauled. They can be utilized for feeding from either in or out of the lot; however, it does not eliminate unloading labor.
- c. Self-unloading wagons are adapted to medium or large units where the feed must be hauled. This equipment operates best from fence line feeders.
- d. Power-scoop feeding is adapted to use for medium or large units where the hauling distance is short and where the scoop can be loaded directly from storage.
- e. Bunk-conveyors are adapted to units where feeding can be carried on directly from storage to feeder. Such systems are normally permanently located. They eliminate most of the physical labor.

10. The use of permanently located feeders will normally require surfacing the area adjacent to the feeder. A four to six inch reinforced concrete slab provides the most permanent and durable surface.

11. Self-feeding can be employed to reduce feeding labor in many programs.

- a. Self-feeding grain is suited to creep feeding operations and some full feeding programs. It demands careful management to start such a system.
- b. Self-feeding hay is limited to chopped or ground hay at the

present time. This system does not permit rationed feeding unless sufficient feeder space is provided for all animals at one time.

c. Self-feeding silage to date has been largely from horizontal silos.

The system is adapted to calf or yearling wintering programs. Allow from three to six inches of feeder space per head.

12. Conveying machines aid in the automaton of feed handling operations by providing efficient economical means of loading, unloading, transporting, and distributing various livestock feeds.

13. The hopper-bottom bin provides a gravity flow non-mechanical method of feed movement. The minimum recommended floor slopes are 45 degrees from the horizontal for whole grain and 60 degrees for ground feeds.

14. Belt conveyors provide an efficient and fast method of moving feeds horizontally long distances. They demand careful design for successful operations.

15. Chain conveyors provide a relatively simple and inexpensive method of moving feeds horizontally or at an incline. They are not as efficient mechanically and do not operate as quiet as belt conveyors. The wide construction tolerances and simplicity make this an excellent system for handling most livestock feeds.

16. Screw conveyors are relatively simple and inexpensive feed moving equipment. They require a high power factor and individual sections are limited in length. The screw will move feeds either horizontally or vertically.

17. Bucket elevators are the most efficient method for moving grains or ground feeds vertically. They are relatively simple to construct but slightly more expensive to install than a chain conveyor.

18. Pneumatic conveyors provide a mechanically simple and relatively inexpensive method of moving livestock feeds. They can be used to handle most of the livestock feeds. The direction of conveying can be changed with this system. The high power requirement, mechanical damage to conveyed products, and need for specific engineering data for design are the leading disadvantages for the system.

ACKNOWLEDGMENT

The author wishes to express his appreciation to Professor F. C. Fenton for his suggestions and assistance in directing the investigation, to Professor George H. Larson for his assistance in assembling and editing the information secured, to the Extension livestock specialists, Lot F. Taylor, W. A. Moyer, and V. E. McAdams for their helpful suggestions throughout the study, and to the many county agricultural agents who supplied helpful information.

This study was made possible with the cooperation of many Kansas livestockmen who gave freely information gained through years of experience in livestock handling and feeding.

LITERATURE CITED

- (1) Beef cattle equipment. Ext. Bul. 715, Oregon State College, October 1955.
- (2) Brennen, C. A.
Hay rack and feed trough for weaner calves and yearlings. Agr. Exp. Sta. Bul. 178, Univ. of Nevada, March 1948.
- (3) Brown, Robert H. and G. E. Henderson.
Selecting farm electric motors, controls, and drives. Bul., Agr. Engr. Dept., Univ of Georgia, May 1953.
- (4) Cuff, Ray L.
Suggestions for utility alley for sorting, holding, spraying, loading, and treating livestock. National Livestock Loss Prevention Board, Kansas City 15, M o.
- (5) French, Charles E.
"Chores, how to break your farms biggest bottleneck. Cappers Farmer, January, 1954, 26-27, 46-47 p.
- (6) Hardin, L. S.
Work simplification news letter. Purdue work simplification laboratory, Issue No. 19, July, 1948, 5 p.
- (7) Henderson, S. M. and R. L. Perry.
Agricultural process engineering. New York: John Wiley and Sons Inc., 1955.
- (8) Huber, M. G.
Corrals for spraying cattle. Ext. Cir. 521, Oregon State College, August, 1948.
- (9) Kleis, R. W.
Operating characteristics of pneumatic grain conveyors. Agr. Exp. Sta. Bul. 594, Univ. of Ill., October, 1955.
- (10) Knight, William H. and John E. Dixon.
Electric elevators and conveyors find many farm uses. Farm Electrification Leaflet No. 30, Univ. of Idaho, June, 1955.
- (11) Koch, Robert M.
A new corral plan for big herds. Nebraska Exp. Sta. Q uarterly, Winter, 1954-55, 3 p.
- (12) Krewatch, A. V. and Amos R. Meyer.
Cattle chutes for easier handling. Univ. of Maryland fact sheet 77, January, 1954.

- (13) Martin, J. W. and June Roberts.
Feed grinding with small electric motors. Ext. Bul. 87, Kansas State College, September, 1941.
- (14) Miller, R. N. and Walter Tolman.
A beef cattle corral. Ext. Cir. No. 84, State College of Washington, June, 1944.
- (15) Shove, Gene C., Kenneth K. Barnes, and Hobart Beresford.
A self-feeding hay storage structure. Iowa Farm Science, June 1954, Vol. 8, No. 12.
- (16) Swegle, Wayne A.
Newest farm science materials handling. Successful Farming, Meridith Publishing Co., Des Moines 3, Iowa, 1955.
- (17) The farm book, a guide to better farming and better buildings, West Coast Woods, December 1947, 61-62 p.
- (18) VanArsdall, R. N. and Thayer Cleaver.
Handling silage and concentrates for beef cattle in dry lots. Ext. Cir. 714, Univ. of Ill., January, 1954.
- (19) Vaughn, Laurence N. and Lowell S. Hardin.
Farm work simplification. New York: John Wiley and Sons Inc., 1949.

APPENDIX

[Faint, illegible text, possibly bleed-through from the reverse side of the page]

Table 6. Blowers. (Brown and Henderson, 3)

Feed	Height (ft)	Capacity (bu or tons per hr)	Speed (rpm)	Motor Size (hp)
Grain	20	300-900 bu	700-1000	5 - 7½
Dry cut hay	30	16 tons	765	7½
Dry cut hay	40	7 tons	700	7½
Silage	30	25 tons	765	7½
Silage	40	14 tons	700	7½

Table 7. Power requirements of feed mixers. (3)

Size and Approx. Capacity (lbs per batch)	Operating Speed (rpm of pulley)	Motor Size (hp)
500	200-400	1
700	200-400	1½
1000	200-400	2
1200	200-400	3
2000	200-400	5
3000	200-400	7½

Table 8. Power requirements for flight type conveyors. (3)

Length (ft)	Approx. Capacity (bu per min)	Speed Drive Pulley (rpm)	Motor Size (hp) Horiz. to 35° - 40° Angle
16-24	15-20	150-225	1
26-28	15-20	150-225	1½
30-36	15-20	150-225	2
38-50	15-20	150-225	3

Table 9. Power requirements of bucket type elevators. (3)

Approx. Capacity (bu per hr)	Discharge Height (ft)	Speed (rpm)	Motor Size (hp)
100	6-50	(varies with elevator design and size head pulley)	1/3
200	6-34		1/3
	35-50		1/2
300	6-24		1/3
	25-50	1/2	
350	6-19	1/3	
	20-39	1/2	
500	40-50	3/4	
	6-24	1/2	
700	25-44	3/4	
	6-14	1/2	
	15-34	3/4	
	35-39	1	

Table 10. Power requirements of horizontal screw conveyors. (3)

Size Screw (in)	Length (ft)	(Approx. Capacity)		Maximum Recommended Auger Speed	Motor Size (hp)
		Corn & Beans	Small Grain	(rpm)	
		: bu per hr	: bu per hr		
4	10-20	44	64	120	1
	21-40				1½
6	10-20	180	196	115	1
	21-40				1½
9	10-20	520	672	105	1½
	21-40				2
10	up to -10	720	868	100	1½
	11-30				2
12	10-20	1240	1440	95	2
	21-40				3
14	up to -10	2000	2240	90	2
	11-30				3

Table 11. Power requirements of inclined screw conveyors. (3)

Size Screw (in)	Length (ft)	Approx. Capacity*	Maximum Recommended Auger Speed	Motor Size (hp)
		(bu per hr)	(rpm)	
6	10-12	(450	(250	¾
	13-18	to	to	1 1/2
	19-30	550)	350)	2
	31-40			3
9	10-12	(700	165	1 1/2
	13-18	to		2
	19-30	800)		3
	31-45			5

* Capacity increases at lower angle. Minimum figure for wheat, maximum figure for oats.

Table 12. Power requirements of vertical type screw conveyors. (3)

Size Screw (in)	Length (ft)	Approx. Capacity*	Maximum Recommended Auger Speed	Motor Size (hp)
		(bu per hr)	(rpm)	
6	up to 10	(230	175	1
	11-20	to		2
	21-40	500)		3
9	up to 10	(730	165	1½
	11-20	to		3
	21-40	1130)		5
12	up to 10	(1650	150	3
	11-20	to		5
	21-40	2500)		7½

* Depends on weight of grain. Minimum wheat, maximum oats.

Table 13. Hammer mill grinding with small electric motors. (3)

Grain or Forage	Fineness	Motor Size			
		1½ (hp)	3 (hp)	5 (hp)	7½ (hp)
		(lbs per hr)			
Shelled Corn	Coarse	---	---	---	---
	Medium	280-700	510-980	750-2030	1750-2750
	Fine	200-410	430-740	450-1050	1023-1150
Ear Corn	Coarse	---	---	---	---
	Medium	---	---	375-1240	800-1625
	Fine	---	---	---	---
Snapped Corn	Coarse	---	---	670-860	---
	Medium	---	314-500	550-740	750-1290
	Fine	---	---	410-1000	---
Oats	Coarse	400-680	---	---	---
	Medium	140-230	180-290	375-750	536-1300
	Fine	110-150	---	250-520	---
Barley	Coarse	260-675	---	500-1750	1100-2300
	Medium	80-260	---	510-950	---
	Fine	60-85	---	321-420	---
Wheat	Coarse	---	---	---	---
	Medium	460-700	---	770-2240	---
	Fine	150-480	390-670	---	1720-2770
Kafir	Coarse	---	---	---	---
	Medium	500-720	---	---	---
	Fine	270-550	---	---	---
Alfafa Hay	Coarse	---	410-480	---	---
	Medium	---	270-410	560-740	770-1250
	Fine	---	---	125-400	250-740
Soy Bean Hay	Coarse	---	---	---	---
	Medium	---	---	275-500	700-850
	Fine	---	---	---	---

* The blanks indicate no data available rather than inability to grind feed to the specified fineness.

Table 14. Power requirements for roller type mills. (3)

Approx. Capacity (lbs per hr)	Operating Speed (rpm)	Motor Size (hp)
150-190		½
450-850	(250	1
700-2200	to	2
1200-3000	600)	3
1800-7500		5
3500-12000		7½

Table 15. Plate or burr mill grinding with electric motors. (3)

Grain	Fineness:	Motor Size				
		$\frac{1}{2}$	$1\frac{1}{2}$	3	5	$7\frac{1}{2}$
		(hp)	(hp)	(hp)	(hp)	(hp)
		(lbs per hr)				
Shelled Corn	Coarse	90	750-1150	2200-3760	2850-4800	---
	Medium	---	300-800	800-2200	1400-2400	1630-3900
	Fine	35	175-300	750-930	800-1400	---
Ear Corn	Coarse	---	---	---	---	---
	Medium	---	---	460-525	550-1200	1000-1700
	Fine	---	---	---	---	---
Oats	Coarse	60-200	200-350	340-710	---	740-1100
	Medium	50-160	120-210	---	550-771	640-900
	Fine	40-100	100-150	450	---	---
Barley	Coarse	145	425-680	930	800-1200	1800-2000
	Medium	---	150-425	330-720	798-808	---
	Fine	70	---	---	---	---
Wheat	Coarse	180	860-1250	---	---	---
	Medium	---	370-860	---	---	---
	Fine	100	---	---	---	---
Kafir	Coarse	---	1230-1380	---	---	---
	Medium	---	700-1230	---	---	---
	Fine	---	210-700	---	---	---

* The blanks indicate no data available rather than inability to grind feed to the specified fineness.

Table 16. Comparative working corral fence material prices.

2 in. plank	3 in. pole	2 in. pipe	sucker rod	Landing mat
¢ per bd ft	¢ per ft	¢ per ft	¢ per ft	¢ per ft
6	2 1/4	5	3 3/4	15
8	3	6 2/3	5	20
10	3 3/4	8 1/3	6 1/4	25
12	4 1/2	10	7 1/2	30
14	5 1/4	11 2/3	8 3/4	35
16	6	13 1/3	10	40
18	6 3/4	15	11 1/4	45
20	7 1/2	16 2/3	12 1/2	50

Read comparative prices horizontally.

Comparison does not include erection and maintenance costs.

Pole fence life considered 50% of board fence, others considered equal.

Comparable fences: 5, 2 x 6 planks treated; 6, 3inch poles; 6, 2 inch pipe; 8, sucker rods; 2, 3 foot landing mat.

Table 17. Comparative holding pen or feeding lot fence material prices.

1 x 6 fence bd ¢ per bd ft	: 2 x 6 : plank : ¢ per : bd ft	: 3 inch : pole : ¢ per : foot	: sucker : rod : ¢ per : foot	: landing : mat : ¢ per : foot	: 42 inch : wire : ¢ per : foot	: 2 inch : pipe : ¢ per : foot
6	3 3/4	1 1/4	2 1/2	11 1/4	3 3/4	3
8	5	1 2/3	3 1/3	16 1/4	6 1/4	4
10	6 1/4	2 1/12	4 1/6	21 1/4	8 3/4	5
12	7 1/2	2 1/2	5	26 1/4	11 1/4	6
14	8 3/4	2 11/12	5 5/6	31 1/4	13 3/4	7
16	10	3 1/3	6 2/3	36 1/4	16 1/4	8
18	11 1/4	3 3/4	7 1/2	41 1/4	18 3/4	9
20	12 1/2	4 1/6	8 1/3	46 1/4	21 1/4	10

Read comparative prices horizontally.

Comparison does not include erection and maintenance costs.

Pole fence life considered 50% board fence life, others equal.

Comparable fences: 5, 1 x 6 fence boards treated; 4, 2 x 6 planks treated; 6, poles; 5, 2 inch pipe; 6, sucker rod or cable; 1, 3 foot landing mat with 3 barbs; 1, 42 inch woven wire with 3 barbs and 1, 2 x 8 plank.

AUTOMATON OF LIVESTOCK
HANDLING AND FEEDING

by

LEO THEODORE WENDLING, JR.

B. S., Kansas State College of Agriculture and Applied Science, 1947

AN ABSTRACT OF A THESIS

submitted in partial fulfillment of the

requirements for the degree

MASTER OF SCIENCE

Department of Agricultural Engineering

KANSAS STATE COLLEGE
OF AGRICULTURE AND APPLIED SCIENCE

1956

Livestock production is a highly competitive business. The growth, progress, and prosperity of those engaged in this business is controlled to a large extent by the efficiency of production. This study on the automaton of livestock handling and feeding deals with production efficiency as affected by livestock handling and feeding equipment. The proper selection and application of this equipment can insure more effective use of labor, aid in securing maximum feed utilization, and promote better management practices. The purpose of the study was to establish the guides needed to insure effective application by livestockmen.

The information presented represents an accumulation of technical and empirical facts on cattle handling and feeding facilities. Materials are presented on the layout, design, and construction of livestock working corrals, livestock feeding lots and equipment, and feed handling equipment. The information was assembled from a wide range of sources. Available printed materials: books, bulletins, circulars, and periodical news articles on the subject were reviewed. The opinions of numerous livestockmen and animal husbandry specialists were secured regarding desirable equipment. Many observations of existing equipment and systems have been made by the author while working with livestockmen during the past eight years.

The first observation made regarding the automaton of livestock handling and feeding was that there is no universal answer to the problem. Each operation presents a new set of resources and conditions which must be evaluated. Convenience, safety, simplicity, and flexibility are the criterion upon which a practical design can be made. The systematic analysis of present conditions, the needs, and possible solutions provides the basis for developing an efficient

effective design.

The working corral is essential for efficient cattle handling. Such a corral provides the pens and equipment for holding, crowding, treating, loading, unloading, and weighing cattle. The corral should occupy a well drained area adjacent to the livestock with good access to a road system. The pens for these corrals must be strong and durable. The gates must be equally strong, easy to operate, and have secure fastenings. The major parts of a working corral are: two holding pens inclosing a total area of from 20 to 40 square feet per head, one crowding pen inclosing at least 400 square feet, a working chute 25 to 30 feet long, a loading chute, a squeeze chute or head gate, and possible scales, cutting gates, and spray pen.

The demand for livestock feeding lots and equipment is quite varied depending on the production program. The generally recommended lot area required for feeding yards is from 150 to 300 square feet per head in unsurfaced lots and 75 square feet in surfaced lots. Labor efficiency in feeding can be accomplished by mechanizing the operation, installing new or better feeding equipment, and rearranging the feeding schedule or layout. Fence line bunks provide an efficient method of corral feeding hauled feeds. Portable bunks are the proper choice where maximum flexibility is desired. Permanent bunks with distribution conveyors are efficient for feeding directly from storage to bunk. Two feet of feeding space per head is the generally accepted design allowance. When self-feeding is employed the space requirement can be reduced to from six to nine inches per head on grain rations and three to six inches on silage. The use of permanently located feeding equipment will require the installation of a surfaced feeding floor along the bunk in most areas. A four to six inch

concrete slab provides the most permanent and durable surfacing material.

The use of conveyors will materially reduce the labor required to load, unload, transport, and distribute livestock feeds. Conveyors adapted to livestock feed movement jobs include: belt conveyors, chain conveyors, augers, bucket elevators, and pneumatic conveyors. The belt conveyor is best suited to the fast movement of relatively large volumes of granular materials horizontally. The belt conveyor operates quietly and is mechanically efficient but it is relatively expensive. Chain conveyors are the most widely used livestock feed moving device. They are good for horizontal and incline conveying of grains, hay, silage, and sacked materials. They are simple to design or build and less expensive than belt conveyors, however, they are slower, and less efficient mechanically. The screw conveyor provides a relatively simple and inexpensive method of moving feed grains or chopped roughages. Augers can be used for horizontal, incline, or vertical feed movements. The high power factor and limited unit length limit more general use of this conveyor. The bucket elevator is one of the most efficient devices for moving whole or ground grains vertically. This equipment is well suited to feed processing installations which utilize overhead hopper-bottom bins. The blower or pneumatic conveyor provides a relatively simple and inexpensive method of moving feeds over an irregular path. The high power requirement and physical damage to conveyed products are the leading disadvantages of these conveyors.

The automaton of livestock handling and feeding can definitely aid the livestockman toward the development of a more efficient and profitable business.

