

ANALYSIS AND DESIGN OF AN ELEVATED REINFORCED CONCRETE  
WATER TANK OF THE INTZE TYPE

by

BALBIR SINGH SANDHU

B. Sc., the University of Glasgow, 1957

---

A MASTER'S REPORT

submitted in partial fulfillment of the

requirements for the degree

MASTER OF SCIENCE

Department of Civil Engineering

KANSAS STATE UNIVERSITY  
Manhattan, Kansas

1966

Approved by:

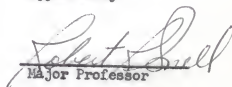
  
Major Professor

LD  
2668  
R4  
1966  
S217

TABLE OF CONTENTS

INTRODUCTION .....	1
PURPOSE .....	2
FUNDAMENTAL FORMULAS .....	3
NUMERICAL DESIGN EXAMPLE .....	18
DISCUSSION AND CONCLUSIONS .....	31
SYMBOLS AND ABBREVIATIONS .....	35
ACKNOWLEDGEMENTS .....	38
BIBLIOGRAPHY .....	39

## INTRODUCTION

The simplest type of reinforced concrete elevated tank is the circular tank having a flat roof and floor of beam and slab design. This type of construction is not always the most economical. For tanks with capacity of the order of 100,000 gallons or over, the choice of a domed roof and floor is most economical even after considering the greater cost of curved forms.

The Intze tank, named after the inventor O. Intze, is a modification of the domed bottom and roof type tank. This type of tank was originally designed to obtain balanced inward and outward horizontal thrusts on the ring beam at the tops of the columns supporting the tank. Thus, when the tank is full, there is no hoop stress in the ring beam. The four principal parts of an Intze tank are the domed roof, the cylinder, the coned portion and the domed bottom. A rib encircling the edge of the roof dome is provided to take the horizontal thrust. The ring beam provided at the junction of domed bottom and conical portion transmits the load to the columns.

## PURPOSE

The purpose of this report is to develop and use the formulas for membrane stresses in shells of the form of a surface of revolution and loaded symmetrically with respect to the axis.

These formulas are used to analyse the stresses in the roof and bottom domes of the tank, the cylindrical section and the conical section. In the analysis of the cylindrical and conical sections, the same membrane formula is used with the modification that the radius of curvature of the shell of the surface of revolution becomes  $\infty$  in one direction. A formula for economical tank dimensions is derived.

The procedure for designing a 200,000 gallon capacity water tank is presented showing the use of the various formulas and some additional design considerations including shear at the edges of the domes and shear and bending in the conical section.

## FUNDAMENTAL FORMULAS

### Membrane Theory of Shells

The roof and bottom domes of an Intze tank are spherical domes with the shell thickness small compared with the other dimensions and with the radii of curvature. In the deformation of thin shells the bending stresses are small compared with direct stresses and can be neglected provided that the conditions at the supports are such that the shell can expand freely. These direct stresses are called membrane stresses and the theory of shells based on the omission of bending stresses is called the membrane theory.

Consider a shell of small thickness  $t$ , in the form of a surface of revolution about the vertical axis. Consider the equilibrium of a small element  $ds \times ds$ . Suppose  $Z$  is the intensity of loading normal to the surface of the element of membrane in the direction as shown in Fig. 1 (a).

Then equating forces acting on an element  $ds \times ds$  gives

$$N_{\phi} (d\phi \times ds) + N_{\theta} (d\theta \times ds) = Z \, ds \times ds$$

$$\text{Now } ds = r_1 \, d\phi = r_2 \, d\theta$$

$$\text{Hence } \frac{N_{\phi}}{r_1} + \frac{N_{\theta}}{r_2} = Z$$

which is the general equation of membrane stresses in thin shells.

Sign convention adopted is as follows:

- |                                 |                   |
|---------------------------------|-------------------|
| For $N_{\phi}$ and $N_{\theta}$ | Tension +         |
|                                 | Compression -     |
| For $r_1$ and $r_2$             | Concave inward +  |
|                                 | Concave outward - |
| For $Z$                         | Acting outward +  |
|                                 | Acting inward -   |

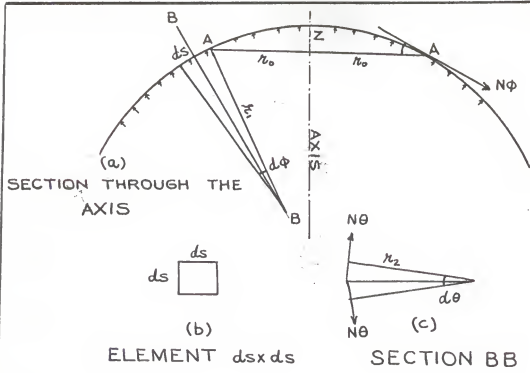

FIG.1. VARIOUS ELEMENTS OF A SHELL OF THE FORM OF A SURFACE OF REVOLUTION

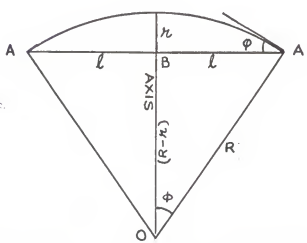

FIG.2. A SECTION THROUGH SPHERICAL DOME

The second equation of equilibrium can be obtained by considering vertical equilibrium of a portion of the shell above section AA.

If  $W$  is the net downward loading on the shell above AA and the angle made by the tangent at A with the horizontal, then

$$W = -2 \pi r_0 N_\phi \sin \phi \quad \text{or} \quad N_\phi = - \frac{W}{2 \pi r_0 \sin \phi} \quad (\text{compression})$$

The two equations can be solved for the membrane forces  $N_\phi$  and  $N_\theta$ .

#### Formulas for Spherical Dome

(1) If the rise,  $r$ , and the span,  $2\ell$ , of a spherical dome are given, the radius of the domed surface,  $R$ , can be found from the formula derived below.

From the right angled triangle OAB, Fig. 2

$$\ell^2 + (R-r)^2 = R^2$$

$$\ell^2 = R^2 - R^2 + 2Rr - r^2$$

$$\ell^2 = r(2R-r)$$

$$\ell^2 = 2rR - r^2$$

$$R = \frac{\ell^2 + r^2}{2r}$$

(2) The angle  $\phi$  is found from the relation

$$\sin \phi = \frac{\ell}{R}$$

(3) The surface area of the dome =  $2 \pi R r = 2 \pi R (R - R \cos \phi)$   
 $= 2 \pi R^2 (1 - \cos \phi)$

#### Formulas for Membrane Stresses in the Domed Roof

Consider a spherical dome of radius  $R$  and span  $2\ell$ . Suppose that the shell is submitted to the action of its own weight plus any snow load and the weight of the roof covering, etc.

Let  $w$  = intensity of loading per unit area.

Suppose it is required to find the membrane stresses  $N_\phi$  and  $N_\theta$  at Point

A, Fig. 3.

The surface area of the dome above plane AA is

$$S = \int_0^\phi 2 \tilde{r} R \sin \phi (R d\phi)$$

$$= 2 \tilde{r} R^2 [-\cos \phi]_0^\phi = 2 \tilde{r} R^2 (1 - \cos \phi)$$

The total load on the domed portion above AA =  $2 \tilde{r} R^2 w (1 - \cos \phi)$ .

Considering the vertical equilibrium of the forces around the circumference of section AA gives

$$N_\phi (\sin \phi) (2 \tilde{r} r_0) + 2 \tilde{r} R^2 w (1 - \cos \phi) = 0$$

where

$$r_0 = R \sin \phi$$

$$\therefore N_\phi = - \frac{(1 - \cos \phi) 2 \tilde{r} R^2 w}{2 \tilde{r} R \sin^2 \phi} = - \frac{R w}{1 + \cos \phi}$$

the negative sign indicating compression.

Applying the general membrane stress formula to solve for  $N_\theta$  gives

$$\frac{N_\phi}{R} + \frac{N_\theta}{R} = Z$$

Where  $Z$  = the intensity of pressure perpendicular to the surface of section AA

now

$$Z = -w \cos \phi$$

therefore

$$N_\theta = ZR - N_\phi$$

$$= -wR \cos \phi + \frac{Rw}{1 + \cos \phi}$$



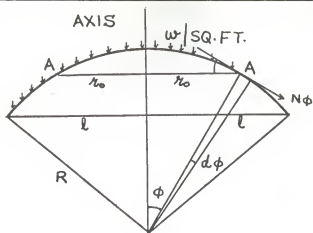

FIG. 3. A SEC. THROUGH THE ROOF DOME

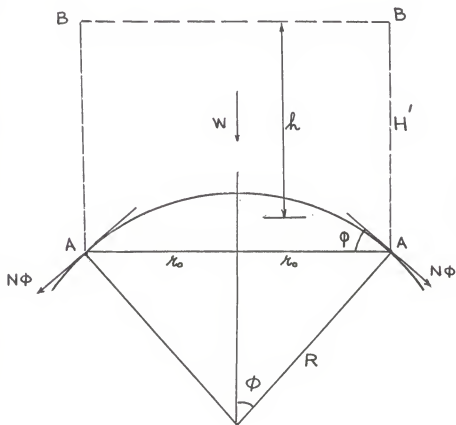

FIG. 4. A SEC. THROUGH THE BOTTOM DOME

or

$$N_{\theta} = R w \left( \frac{1}{1 + \cos \varphi} - \cos \varphi \right)$$

Formula for the Membrane Stress in the Bottom Dome

The loadings on the bottom dome are the water pressure acting normal to the dome surface and the dead weight of the dome. The dead weight of the dome is generally small compared with the water pressure. For vertical equilibrium of the portion above AA, Fig. 4

$$(2\pi r_0) N_{\varphi} \sin \varphi + W = 0$$

$$r_0 = R \sin \varphi$$

$$W = 62.5 (\pi r_0^2 h) = 62.5 \times \pi R^2 h \sin^2 \varphi$$

Therefore

$$N_{\varphi} = - \frac{W}{2\pi R \sin^2 \varphi} = - \frac{62.5 h R}{2}$$

where

W = the weight of the cylinder of water above AA

h = the average height of the cylinder of water ABBA

and

$$N_{\theta} = ZR - N_{\varphi}$$

where

Z = -62.5 x height of water column at A

$$= -62.5 \times H$$

Formula for Determining the Correct Geometry to Insure that the Stress in the Supporting Ring will be Zero

Suppose

$W_1$  = the weight of the domed floor and the water above it.

$W_2$  = sum of the weights of the roof and the wall loads plus the weight of

the inclined portion of the floor and the weight of the water above it, and that  $\alpha$  and  $\beta$  are the angles of inclination as shown in Fig. 5.

Let  $L$  = the perimeter of the supporting ring.

Considering forces on the supporting ring from the domed bottom:

Vertical load from the dome per unit length of the ring wall =  $\frac{W_1}{L}$ .

In addition to the vertical force on the ring an outward horizontal force is exerted by the dome on the ring.

Let  $N_\phi$  = the direct membrane force per unit length in the domed shell near the edge.

Then considering vertical equilibrium of the domed bottom gives

$$N_\phi \sin \alpha \times L = W_1$$

$$N_\phi = \frac{W_1}{L \sin \alpha}$$

Horizontal thrust per unit length on the ring beam due to this is

$$\begin{aligned} H_1 &= N_\phi \cos \alpha \\ &= \frac{W_1}{L} \cot \alpha \end{aligned}$$

which is outward.

The horizontal thrust inward per unit length on the ring beam due to load  $W_2$  is

$$H_2 = \frac{W_2}{L} \cot \beta .$$

For the hoop force in the ring beam to be zero,  $H_1 = H_2$

or

$$\frac{W_1}{L} \cot \alpha = \frac{W_2}{L} \cot \beta$$

or

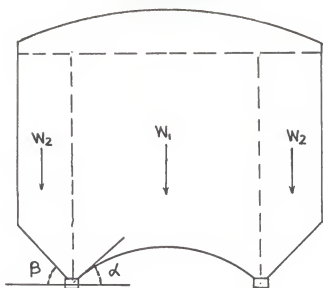

FIG. 5. A SECTION THROUGH THE TANK SHOWING THE WEIGHT OF WATER ACTING ON THE BOTTOM

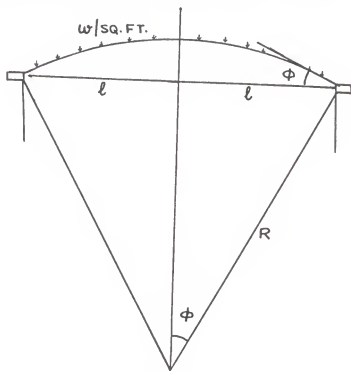

FIG. 6. A SECTION THROUGH THE ROOF DOME AND RIB AROUND THE ROOF DOME

$$W_1 \cot \alpha = W_2 \cot \beta$$

Formula for Stress in the Rib at the Top of the Wall

Let

$w$  = weight per square foot of the roof concrete and any covering and insulating material including the snow load, etc., as shown in Fig. 6.

$$\text{Area of the roof surface} = 2 \pi R r$$

$$\text{Total load from the roof} = 2 \pi R r w$$

$$\begin{aligned} \text{Load per unit length of the rib} &= \frac{2 \pi R r w}{2 \pi \ell} \\ &= \frac{R r w}{\ell} \end{aligned}$$

Horizontal thrust on the rib due to this is  $H_1 = \frac{R r w}{\ell} \cot \varphi$  per unit length.

Tensile force  $T$  in the rib due to the horizontal thrust is given by

$$2T = \frac{R r w}{\ell} \cot \varphi \times 2 \ell$$

or

$$T = R r w \cot \varphi$$

The rib must be strong enough to resist this tension.

Formula for Membrane Stresses in the Conical Bottom

Suppose it is required to find the membrane stresses at point A, Fig. 7.

$H$  = total depth of water column at A.

Applying the formula for the membrane forces

$$\frac{N_{\theta}}{r_1} + \frac{N_{\phi}}{r_2} = Z$$

In this case

$$r_1 = \infty$$

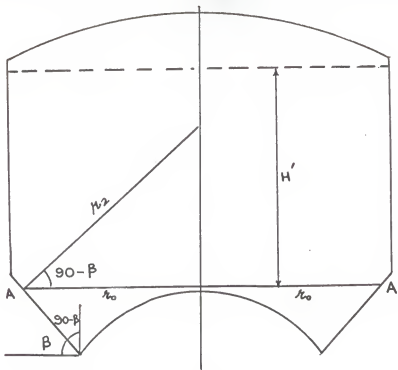

FIG. 7. A SECTION THROUGH THE TANK SHOWING SEC. AA OF THE CONICAL BOTTOM

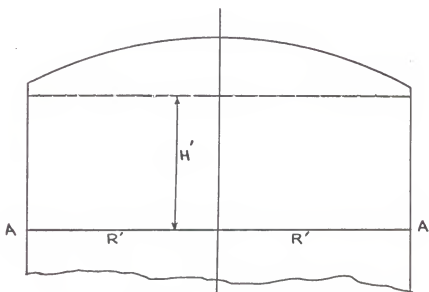

FIG. 8. A SECTION THROUGH THE TANK SHOWING SEC. AA OF THE CYLINDRICAL WALL

and

$$r_2 = \frac{r_0}{\cos (90-\beta)}$$

and

$$Z = w' H$$

where

$w'$  = unit weight of water

Hence

$$N_{\theta} = r_2 Z = w' H \frac{r_0}{\cos (90-\beta)} \text{ (tension)}$$

Considering vertical equilibrium of forces around the circumference AA gives

$$-W' = N_{\phi} \cos (90-\beta) 2 r_0 \text{ or } N_{\phi} = \frac{-W'}{2 r_0 \cos (90-\beta)}$$

where

$W'$  = the sum of the weights of the roof and the wall loads and the weight of the water on the conical portion above AA.

$r_0$  = the radius of the circle of intersection of the conical portion and the horizontal plane through A.

#### Formula for Membrane Stress in the Vertical Wall of the Tank

Suppose it is required to determine membrane forces at section AA,

Fig. 8.

Let  $H$  = height of water column above AA.

Then using the membrane stress formula

$$\frac{N_{\theta}}{r_1} + \frac{N_{\phi}}{r_2} = Z$$

Here

$$r_1 = \infty$$

$$r_2 = R$$

$Z = w' H$  where  $w'$  = weight of water per cu. ft.

Then

$$N_{\phi} = ZR = w' H R \text{ (tension)}$$

Again considering vertical forces gives

$$W_1' = -2 \pi R N_{\phi} \text{ or } N_{\phi} = -\frac{W_1'}{2 \pi R} \text{ (compression)}$$

where

$W_1'$  = sum of the weights of the roof and the wall above section AA including snow loads, etc.

#### Formula for Economical Tank Dimensions

Suppose it is required to design a tank of capacity  $V$  cu. ft. Further suppose that

$C_W$  = cost per square foot of tank walls complete including reinforcement, concrete, shuttering, etc.

$C_R$  = cost per square foot of roof including water proofing.

$C_F$  = cost per square foot of floor including reinforcement, mass concrete, water proofing, rendering, etc.

Let

$D$  = diameter of tank in feet

$H$  = average depth of tank

Consider the tank to be a cylinder of diameter  $D$  and height  $H$ . Assume the roof and the bottom to be flat for the purpose of calculating surface areas. These assumptions are justified since the roof and the bottom domes are flat domes and the error due to this assumption is negligible.

Then total cost  $C$  of the tank is given by



$$C = \tilde{w} D H C_W + \frac{\tilde{w} D^2}{4} C_F + \frac{\tilde{w} D^2}{4} C_R.$$

$$\text{Also } V = \frac{\tilde{w} D^2}{4} H$$

or

$$H = \frac{4V}{\tilde{w} D^2}.$$

Hence

$$C = D \times \frac{4V}{D^2} C_W + (C_F + C_R) \frac{\tilde{w} D^2}{4}$$

or

$$C = \frac{4V}{D} C_W + (C_F + C_R) \frac{\tilde{w} D^2}{4}.$$

Differentiating this with respect to D gives

$$\frac{dc}{dD} = -\frac{4V}{D^2} C_W + (C_F + C_R) \frac{\tilde{w} D}{2}$$

Now the cost is a minimum when  $\frac{dc}{dD} = 0$ .

Thus for the most economical size  $\frac{dc}{dD} = 0$ .

or

$$\frac{4V}{D^2} C_W = (C_F + C_R) \frac{\tilde{w} D}{2}$$

or

$$D^3 = \frac{8V C_W}{\tilde{w} (C_F + C_R)}$$

or

$$D = 2 \left[ \frac{V C_W}{\tilde{w} (C_F + C_R)} \right]^{\frac{1}{3}}.$$

Since the roof dome and bottom dome of the tank are flat domes, the stresses are always compressive in the roof and bottom. On the other hand stresses in the wall are tensile due to hoop forces. In actual design calculations it is found that the average thickness of the tank wall is nearly twice the thickness of the roof or bottom dome. Also, construction of the vertical reinforced concrete wall including shuttering is more difficult than the domed roof and bottom. In general, the roof and bottom domes are of equal thickness.

From the foregoing discussion it follows that costs per square foot of the roof and bottom domes, respectively, are equal and the average cost per square foot of the vertical wall is approximately twice that for the roof or bottom.

Thus assuming

$$C_F = C_R = \frac{C_W}{2}$$

the formula for economical diameter becomes

$$D = 2 \left[ \frac{V}{\pi} \right]^{\frac{1}{3}}$$

The height of the tank is given by

$$H = \frac{V}{\pi D^2} = \frac{4V}{\pi D^2}$$

but

$$V = \frac{\pi D^3}{8}$$

hence

$$H = \frac{4}{D^2} \times \frac{D}{8} = \frac{D}{2}.$$

Thus for economical size, the diameter of the tank should be equal to twice the average height.

### NUMERICAL DESIGN EXAMPLE

The method of design and the application of the various formulas developed in the preceding sections are illustrated in the following design example. Although the main purpose of the design example is to illustrate the use of the formulas already derived, some practical aspects of design are also discussed. For instance a small bending moment occurs in the bottom dome and in the conical bottom near their junction and provision of steel is made in the upper surface of both at their junction to resist this bending moment. Similarly the shear at vertical sections through the conical bottom slab is considered. This shear is a maximum at the lowest point. The inclined slab is also designed to carry, as a beam between the ribs, the normal component of its own weight and the varying water pressure which acts normal to its surface.

The object of this design example is to illustrate the structural analysis and design procedure for an Intze tank of 200,000 gallon capacity.

#### Allowable Stresses and Constants

Tensile stress in steel in tank walls and conical bottoms,  $f_s = 12,000$  psi.

Compressive stress in steel in the roof and bottom domes,  $f'_s = 16,000$  psi.

Tensile stress on composite concrete section of tank wall,  $f'_c = 200$  psi.

Compressive stress in concrete in domes,  $f_c = 1,000$  psi.

Shear stress in concrete,  $v = 100$  psi.

1:1.5:3 concrete mix proportions.

5,000 psi concrete cube strength at 28 days.

Modular ratio  $m = 15$

Weight of reinforced concrete taken as 150 lb./cu. ft.

The allowable tensile and compressive stresses in steel have been kept low enough to avoid cracking of the concrete and thus ensure water tightness.

Economical Dimensions: -

Capacity of tank in cubic feet  $V = \frac{200,000}{6.25} = 32,000$  cu. ft.

Economical diameter  $D = 2 \sqrt[3]{\frac{V}{\pi}} = 2 \times \left(\frac{32,000}{\pi}\right)^{\frac{1}{3}} = 43.4'$

Adopting  $D = 44$  ft.

Average height to full supply level  $H = \frac{D}{2} = 22$  ft.

The dimensions of the tank are as shown in Fig. 9. Since the thickness of the walls and domes are small compared with the other dimensions, the dimensions shown on the diagram are the centerline to centerline distances.

#### Roof Dome

This is designed as a spherical flat dome with rise,  $r = 5$  ft., at the center. The loadings considered on the dome are the dead weight of dome and roof covering or insulation and the snow load. The loads are considered to be symmetrical about the axis of the dome and unsymmetrical stresses due to wind pressure, volume change and support displacement are ignored. The shell of the dome is considered to be so thin that no bending moment is developed in it, yet it is made of sufficient thickness that there is no danger of buckling.

Assuming shell thickness of 6" the loading on the roof is

Dead weight of 6" shell = 75 lb. per sq. ft.

Roof insulation, etc., say = 25 lb. per sq. ft.

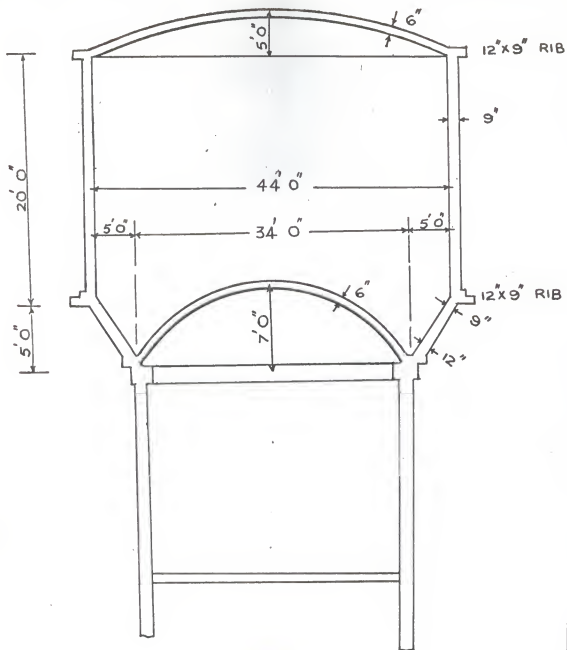

FIG. 9. A SECTION THROUGH THE TANK SHOWING DIMENSIONS AND THICKNESSES OF THE VARIOUS ELEMENTS

$$\text{Snow load} = \underline{10} \text{ lbs./sq. ft.}$$

$$\text{Total} = 110 \text{ lb./sq. ft.}$$

To this is added 50 lb. per square foot allowance for a possible live load.

$$\text{Total intensity of load (w)} = 160 \text{ lb./sq. ft.}$$

$$\text{Radius of curvature of dome } R = \frac{(22)^2 + (5)^2}{2 \times 5} = 50.9$$

$$\sin \phi = \frac{22}{50.9} = .432$$

$$\therefore \phi = 25.6^\circ$$

Meridional force near the edge is

$$N_\phi = - \frac{R_w}{1 + \cos \phi}$$

$$= - \frac{50.9 \times 160}{1 + 0.9} = -4,290 \text{ lbs./ft. (compression)}$$

$$\text{Hoop force } N_\theta = R_w \left( \frac{1}{1 + \cos \phi} - \cos \phi \right)$$

Near the edge ( $\phi = 25.6^\circ$ )

$$N_\theta = 50.9 \times 160 \left( \frac{1}{1.9} - 0.9 \right) = -3,040 \text{ lbs./ft. (compression)}$$

Near the crown (i.e.  $\phi = 0$ )

$$N_\theta = - \frac{R_w}{2} = - \frac{50.9 \times 160}{2} = -4,072 \text{ lb./ft. (compression)}$$

Thus sufficient steel area is provided in both the  $N_\phi$  and  $N_\theta$  directions so that compressive stress in the composite section does not exceed 300 lb./sq. in.

Actually the compressive stress in the dome is very low and a very thin slab might be used but there is not much advantage in reducing the thickness

below 6 inch. A 6 inch slab provides better protection against leakage of water into the tank at no extra expense for shuttering and with some saving in the cost of insulating material.

Using  $3/8" \phi$  bars at 12 inch centers in the  $N_{\phi}$  and in the  $N_{\theta}$  directions throughout the dome is quite satisfactory and gives a steel area,  $A_s = 0.11$  sq. in./ft. width, in each direction.

Stress on composite section in the  $N_{\phi}$  direction near the edge

$$= \frac{N_{\phi}}{12 \times 6 + (m-1) A_s} = \frac{-4290}{72 + 14 \times .11} = \frac{-4290}{73.54} = -58 \text{ lbs./in.}^2 \text{ (compression)}$$

Stress on composite section in the  $N_{\theta}$  direction near the crown

$$= \frac{-4072}{12 \times 6 + 14 \times .11} = -55 \text{ lbs./sq. in. (compression)}$$

Near the edge

$$v = - \frac{2 \pi \times 50.9 \times 5 \times 160}{\pi \times 44 \times 6 \times 12} = 31 \text{ lbs./sq. in.}$$

#### Rib Encircling Edge of Roof Dome

The rib is designed to resist the tensile force due to the horizontal thrust from the dome.

$$\begin{aligned} \text{Tensile force in rib is: } T &= Rr w \cot \phi \\ &= 50.9 \times 5 \times 160 \times \cot 25.6^\circ \\ &= 85,000 \text{ lbs.} \end{aligned}$$

This force is resisted by the steel alone. Allowing a tensile stress of 16,000 lb./sq. in. in steel.

$$\text{Steel area } A_s = \frac{85,000}{16,000} = 5.31 \text{ sq. in.}$$

9 -  $7/8" \phi$  bars are sufficient to provide a steel area of



$$A_s = 5.4 \text{ sq. in.}$$

Vertical Wall: -

The vertical wall is designed to take the hoop forces due to the water pressure. Hoop steel in the form of circular rings is provided in the wall. It is assumed that the junction of the wall and inclined conical bottom is free to displace laterally as well as to rotate so that all of the hydrostatic pressure is resisted by hoop forces and there is no cantilever action provided by the wall. This assumption is however, only partially true since there is partial fixity at the junction. Therefore sufficient vertical reinforcement is provided on the inner side of the wall near the junction to resist the cantilever action. However, for the purpose of designing the hoop reinforcement, it is assumed that all the water pressure is resisted by the hoop steel.

Maximum head of water near the junction = 20 ft.

Water pressure on wall near the bottom =  $20 \times 62.5 = 1,250 \text{ lb./sq. ft.}$

Hoop force per foot height of wall ( $N_s$ ) =  $1,250 \times 22 = 27,500 \text{ lb./ft.}$

Assuming all the force to be resisted by the steel and allowing a tensile stress of 12,000 lb./sq. in., steel area  $A_s = \frac{27,500}{12,000} = 2.29 \text{ sq. in./ft. height.}$

Using 7/8"  $\phi$  bars at 3" centers in the bottom strip of 1 foot height provides the required hoop steel ( $A_s = 2.40 \text{ in.}^2$ ).

The steel area required at other depths is calculated in a similar fashion.

Allowing a tensile stress of 200 lb./sq. in. on the composite concrete section, the thickness  $t$  of the wall near the bottom is given by

$$200 = \frac{N_s}{12t + (m-1) A_s} = \frac{27,500}{12t + 14 \times 2.29}$$

or

$$2,400t = 27,500 - 200 \times 14 \times 2.29 = 27,500 - 6,400 = 21,100$$

or

$$t = \frac{21,100}{2,400} = 8.8''$$

The wall thickness is made 9 inch throughout. Thus adopting a wall thickness of 9 inch, the compressive force  $N_{\phi}$  due to load of roof and wall is found as follows:

$$\text{Surface area of roof dome} = 2\pi \times 50.9 \times 5 = 1,600 \text{ sq. ft.}$$

$$\text{Total load from roof dome} = 1,600 \times 160 = 256,000 \text{ lbs.}$$

$$\begin{aligned} \text{Load per foot of the circumference of wall} &= \frac{256,000}{\pi \times 44} \\ &= 1,850 \text{ lb./ft.} \end{aligned}$$

$$\text{Load/ft. due to dead weight of wall} = 20 \times \frac{3}{4} \times 150 = 2,250 \text{ lb./ft.}$$

$$\text{Total force per foot } (N_{\phi}) = 1,850 + 2,250 = 4,100 \text{ lb./ft.}$$

$$\text{Maximum compressive stress in concrete} = \frac{4,100}{12 \times 9} = 37.6 \text{ lb./sq. in.}$$

Vertical steel in the wall is provided to support the hoop reinforcement.

Thus  $1/2'' \phi$  bars at 12 spacing are provided as vertical reinforcement.

Hoop Steel Area in Vertical Wall at Various Heights: -

$$0-5' \quad 7/8'' \phi \text{ bars at 3'' centers} \quad A_s = 2.40 \text{ in.}^2/\text{ft.}$$

$$5'-10' \quad 3/4'' \phi \text{ bars at 3'' centers} \quad A_s = 1.76 \text{ in.}^2/\text{ft.}$$

$$10'-15' \quad 3/4'' \phi \text{ bars at } 4 \frac{1}{2}'' \text{ centers} \quad A_s = 1.17 \text{ in.}^2/\text{ft.}$$

$$15'-20' \quad 5/8'' \phi \text{ bars at } 6 \frac{1}{2}'' \text{ centers} \quad A_s = .57 \text{ in.}^2/\text{ft.}$$

#### Bottom Domes

In the analysis of the bottom dome, it is assumed that the intensity of pressure on the dome due to the head of water is uniform. Thus the loading on

the bottom dome may be approximated to be a uniform pressure of  $25 \times 62.5 = 1,560$  lb./sq. ft. and the dead weight of the dome, assuming 6 inch shell thickness, is 75 lb./sq. ft.

Total intensity of pressure on the dome is 1,635 lb./sq. ft. acting normal to the surface of the shell.

For zero stress in the supporting ring

$$W_1 \cot \alpha = W_2 \cot \beta$$

where

$W_1$  = weight of dome + weight of water above it

$$W_1 = \left[ (\pi \times 17 \times 17 \times 25) - \pi \times 17 \times 17 \times \frac{5}{8} \right] \times 62.5 + \pi \times 17 \times 17 \times 75 = (227,000 - 1,500) \times 62.5 + 68,000 = 1,408,000 \text{ lbs.}$$

Again

$W_2$  = weight of roof dome + weight of vertical wall + weight of inclined bottom + weight of water on inclined bottom.

Weight of roof dome = 256,000 lbs.

$$\text{Weight of vertical wall} = 20 \times \frac{3}{4} \times \pi \times 44 \times 150 = 312,000 \text{ lbs.}$$

Surface area of inclined bottom =  $\pi \times 39 \times 5 \sqrt{2} = 870$  sq. ft.

Weight of inclined bottom assuming 9" thick =  $870 \times \frac{3}{4} \times 150 = 98,000$  lbs.

Weight of water on inclined bottom =  $\pi \times 36 \times \frac{25}{2} \times 62.5 + \frac{\pi}{4} (44^2 - 34^2) 20 \times 62.5 = 853,500$  lbs.

$$W_2 = 256,000 + 312,000 + 98,000 + 853,500 = 1,519,500 \text{ lbs.}$$

Now with  $\beta = 45^\circ$ , and  $W_1$  and  $W_2$  known, angle  $\alpha$  is found from the relation

$$W_1 \cot \alpha = W_2 \cot \beta$$

which gives

$$1,408,000 \cot \alpha = 1,519,500 \cot 45^\circ$$

$$\therefore \cot \alpha = 1.08$$

$$\therefore \alpha = 42.8^\circ$$

Radius of curvature of bottom dome

$$(R) = \frac{17}{\sin 42.8^\circ} = 25 \text{ ft.}$$

Rise (r) at the center is given by

$$(17)^2 = r(2R-r) = r(50-r)$$

or

$$r^2 - 50r + 290 = 0$$

$$r = \frac{50 \pm \sqrt{2,500 - 1,160}}{2} = \frac{50 - 36.6}{2} = 7 \text{ ft.}$$

#### Membrane Stresses in the Bottom Dome

Equating vertical forces on the dome, the membrane force  $N_\phi$  near the edge is given by

$$N_\phi \sin 42.8^\circ \times \pi \times 34 = -W_1$$

$$\therefore N_\phi = \frac{-1,408,000}{\pi \times 34 \times .68} = -19,400 \text{ lb./ft. (compression)}$$

$N_\theta$  is given by

$$\frac{N_\phi}{25} + \frac{N_\theta}{25} = Z$$

and

$$Z = - (62.5 \times 25 + 75) = -1,635 \text{ lb./sq. ft.}$$

$$-\frac{19,400}{25} + \frac{N_\theta}{25} = -1,635 \quad \therefore \frac{N_\theta}{25} = -859$$

$$\therefore N_\theta = -21,500 \text{ lb./ft. (compression)}$$

For compressive stress of 250 psi on the composite section in the  $N_x$  direction,  $A_s$  is given by

$$250 = \frac{21,500}{12 \times 6 + 14 \times A_s}$$

$$\therefore 14 A_s = \frac{21,500}{250} - 72 = 86.0 - 72 = 14$$

$$A_s = 1.00 \text{ sq. in./ft.}$$

$\frac{3}{4}$ "  $\phi$  bars at 5 in. c/c throughout the dome in both the  $N_x$  and the  $N_y$

directions provides sufficient steel area.

#### Check for Shear

Shear/ft. run near edge of dome

$$= \frac{1,408,000}{\pi \times 34}$$

$$= 13,200 \text{ lb./ft.}$$

The shear stress in the concrete, assuming all shear to be taken by the concrete, is

$$v = \frac{1,320}{12 \times 6} = 180 \text{ lb./in.}^2 \text{ Excessive}$$

$$\text{Steel area provided to take shear } A_s = \frac{13,200}{16,000} = 0.83 \text{ sq. in./ft.}$$

$\frac{3}{4}$ "  $\phi$  bars at 6" c/c.

#### Outer Inclined Conical Portion

At the upper end of the inclined slab there is a vertical load (256,000 + 312,000) = 568,000 lbs. due to the weights of the cylindrical wall, the roof and the roof loads. These produce a shear at the junction of the cylindrical wall and the inclined bottom.

The amount of this shear per foot is

$$V_1 = \frac{568,000}{\pi \times 44} = 4,120 \text{ lb./ft.}$$

The inclined slab must have enough strength to resist this shear.

Assume the inclined slab 9" thick at the upper end.

Shear stress near upper end assuming all shear being taken by concrete

is

$$= \frac{4,120}{12 \times 9} = 38 \text{ lb./in.}^2$$

Shear per foot at the lower end of the inclined slab

$$= \frac{1,519,500}{\pi \times 34} = 14,200 \text{ lb./ft.}$$

Assume the inclined slab 12" thick at the lower end

$$v = \frac{14,200}{12 \times 12} = 99 \text{ lb./sq. in.}$$

The sloping slab is acted on by water pressure varying with the depth of the point under consideration and is designed with steel rings to resist the tension caused by these loads.

The inclined slab is also designed to span as a beam between the ribs. The loading considered is the normal component of its own weight and the varying water pressure. The domed bottom being in compression and the cone in ring tension, a small bending moment occurs at their junction and steel is provided in the upper surface of both at their junction for this reason. This steel extends for the requisite bond lengths into both portions of the structure.

Steel Reinforcement in the Conical Bottom

Near the lower end of the inclined slab

$$N_{\phi} = \frac{-W_2}{2 \pi r_0 \cos 45^\circ} = \frac{-1,519,500}{2 \pi \times 17 \times \frac{1}{\sqrt{2}}} = -20,150 \text{ lb./ft. (compression)}$$

$$N_{\theta} = \frac{w \text{ Hr}_0}{\cos 45^\circ} = \frac{62.5 \times 25 \times 17}{\frac{1}{\sqrt{2}}} = 37,800 \text{ lb./ft. (tension)}$$

Steel area in the  $N_{\theta}$  direction

$$A_s = \frac{37,800}{12,000} = 3.15 \text{ sq. in./ft. } 1" \phi \text{ bars at } 3" \text{ c/c} = 3.16 \text{ sq. in./ft.}$$

Steel Area in the  $N_{\phi}$  DirectionUsing  $3/4" \phi$  bars at 4 in. c/c gives

$$A_s = 1.32 \text{ sq. in.}$$

Compressive stress on the composite section

$$= \frac{20,150}{12 \times 12 + 14 \times 1.32} = 124 \text{ lb./in.}^2$$

Check for Bending

Consider a 1 ft. wide strip spanning between ribs. Assuming simple supports:

$$\text{Span length} = 5 \sqrt{2} = 7.07 \text{ ft.}$$

$$\text{Average water pressure} = 62.5 \times 22.5 = 1,405 \text{ lb./sq. ft.}$$

$$\text{Normal component of dead wt.} = 105 \text{ lb./sq. ft.}$$

$$\text{Total} = 1,510 \text{ lb./sq. ft.}$$

$$\text{Bending moment at the middle} = \frac{1,510 \times (7.07)^2}{8}$$

$$= 9,450 \text{ lb. ft.}$$

Overall thickness at mid-portion =  $10 \frac{1}{2}$ "

Effective depth (d) for beam action =  $10.5 - 1 \frac{1}{2} = 9$ "

$$\begin{aligned} \therefore \text{steel area required } A_s &= \frac{M}{.85 \text{ dfs}} \\ &= \frac{9,450 \times 12}{.85 \times 9 \times 12,000} \\ &= 1.235 \text{ in.}^2 \end{aligned}$$

Using  $\frac{3}{4}$ "  $\phi$  bars at 4" c/c gives  $A_s = 1.32$  sq. in. with 1 in. concrete cover.

Check for Concrete Stress Due to Combined Action of Bending and Direct

Force  $N_q$

Concrete stress due to  $N_q = 124.00$  lb./in. (compressive)

Concrete stress due to bending

$$\begin{aligned} &= \frac{9,450 \times 12}{0.85 \times 9 \times .44 \times 9 \times 12} \times 2 \\ &= 625 \text{ lb./in.}^2 \text{ (compressive)} \end{aligned}$$

Total compression in concrete due to combined action at the mid-section of the inclined slab =  $750 \text{ lb./in.}^2$



## DISCUSSION AND CONCLUSIONS

The analysis of the water tank by the use of membrane theory of shells is found to be quite simple. There are no complicated mathematical formulas involved in this method. The basic assumptions made in the membrane theory are:

- (1) The thickness of the shell is small compared with the radius of curvature and the other dimensions.
- (2) The conditions at the supports are such that the shell can freely expand and no bending stresses are introduced at the edges of the shell.
- (3) The thickness of the shell being small, the membrane stress is assumed to be constant throughout the thickness.

The membrane theory gives satisfactory results only if the above assumptions and conditions are satisfied. Condition (1) is satisfied fairly well in the case of a tank. The ratio of shell thickness to radius of curvature,  $t/R$ , for various components of the tank, was as follows:

	$t/R$
Roof dome	.0098
Bottom dome	.020
Vertical wall	.034
Conical bottom	.030 (average)

In Ref. (9) page 454, it is shown by a rigorous mathematical analysis for a shell of steel (Poisson's ratio  $\nu = 0.3$ ) that in shells of the form of a surface of revolution, loaded symmetrically with respect to the axis, the maximum value of the ratio of bending stress to the membrane stress is  $3.29 t/R$ . Applying similar reasoning to concrete shells, it is thus seen that bending

stresses in thin shells are very small compared with membrane stresses and that membrane theory is quite satisfactory even if condition (2) is not fully satisfied. Condition (2) is however partially satisfied because of the partial fixity of the edges of the shells. This is due to the restraining action of the encircling ribs provided at the junctions of the roof dome and vertical wall, the vertical wall and conical bottom, the conical bottom and the bottom dome. Therefore, some bending stresses are introduced at the junctions of the various components. To take care of these bending stresses, sufficient steel is provided near the junctions as already discussed on pages 22 and 23. The exact solution for the amount of steel to be provided to resist this bending is beyond the scope of this report, but a fairly good approximation can be obtained by considering the fixed-ended beam action of a strip of 1' width acted on by the given loadings. To allow for any uncertainty, the calculated value of steel area may be multiplied by a factor of 2. As this steel to resist bending is only required near the junctions, it makes a very small fraction of the total steel used and it would be justifiable to use even a higher factor of safety than 2.

Assumption (3) is also fairly well justified and membrane stress is fairly uniform throughout the shell thickness.

The formula for economical tank dimensions has been deduced by making use of the minimum value theorem of Differential Calculus. Though a similar formula is given in Ref. (2) page 134, called Dr. E. Kuester's rule which is for circular tanks with flat roof and flat bottom, the writer has derived the formula from first principles for the tank with a domed bottom and roof. In deriving the formula, it is assumed that the surface area of the flat dome is very nearly the same as its projection on the horizontal plane. Also,

the height of the tank is taken as the average depth of water to full supply level.

The formula for zero hoop force in the ring beam supporting the tank is

$$W_1 \cot \alpha = W_2 \cot \beta$$

The value of  $\beta$  is assumed to be  $45^\circ$ . The weights  $W_1$  and  $W_2$  were calculated and substituted in the formula to find  $\alpha$ . In finding  $W_1$  and  $W_2$ , some approximations were used but the error introduced is less than 2%. This is found by working out exact values of  $W_1$  and  $W_2$  using the geometry of the cone and the sphere. Although there is no hoop tension in the ring beam supporting the tank, there are large bending and torsional effects. The beam can be designed by conventional methods but this was not in the scope of this report.

In the design of the tank, the loadings considered were due to

- (1) Water pressure in tank
- (2) Self weight of various components of structure
- (3) Snow load on roof

In addition to the above, other possible effects causing stresses in a structure are: wind loads, stresses due to temperature change, stresses due to settlement of supports and earthquake stresses.

In any structural design problem, it is of basic importance to determine the various possible loadings and stresses so as to design the structure for combinations of various effects and loadings. It is therefore necessary to mention the effects of wind, temperature change, settlement and earthquakes and to show whether or not it is justified to neglect these in the design of the tank. Since the height of the tank is small compared with the total height of the tower, the wind forces have very little effect on the design

of the tank, though these become prominent in the design of the columns, column bracings and footings. Again, although settlement of the foundations would cause severe stresses in the columns, ring beam and the footings, it does not have any important adverse effect on the shell. Regarding temperature change, since the reservoir remains full of water at most times, there is not much differential change of temperature in the shell.

Similarly earthquake effects have not been accounted for in the design of the shell. Most probably this effect will also be confined to the design of column footings, beams and column bracings and will have small effect on stresses in the shell portion.

From the analysis presented in the report and the foregoing discussion, it is found that the method of analysis of the tank shell by the membrane theory is easy, reliable and gives satisfactory results.

## SYMBOLS AND ABBREVIATIONS

## Symbols.

$A_s$  = Steel area, in.<sup>2</sup>

$C_W$  = Cost per sq. ft. of wall.

$C_R$  = Cost per sq. ft. of roof.

$C_F$  = Cost per sq. ft. of floor.

$d$  = Distance from the concrete compression edge to the centroid of tensile reinforcement, in.

$D$  = Diameter of the tank, ft.

$f_s$  = Permissible tensile stress in steel, psi.

$f'_s$  = Permissible compressive stress in the steel, psi.

$f_c$  = Permissible compressive stress in the concrete, psi.

$f'_c$  = Permissible tensile stress on the composite concrete section, psi.

$h$  = Average height of the water column, ft.

$H$  = Height of the tank, ft.

$H'$  = Depth of water, ft.

$H_1$  = Outward horizontal thrust per ft. on ring beam due to the bottom dome, lbs./ft.

$H_2$  = Inward horizontal thrust per ft. on ring beam due to inclined section, lbs./ft.

$\ell$  = One half the span of dome, ft.

$L$  = Circumference of the ring beam supporting the tank, ft.

$m$  = Modular ratio.

$M$  = Bending moment, lbs. in.

$N_\phi$  = Membrane force/ft. in the meridional plane, lbs./ft.

- $N_{\theta}$  = Membrane force/ft. in tangential direction, lbs./ft.  
 $r$  = Rise of the dome, ft.  
 $r_0$  = Radius of the circle of intersection, ft.  
 $r_1$  = Radius of curvature of the surface in  $N_{\phi}$  direction.  
 $r_2$  = Radius of curvature of the surface in  $N_{\theta}$  direction.  
 $R$  = Radius of curvature of the spherical dome, ft.  
 $\hat{R}$  = Radius of cylindrical portion, ft.  
 $S$  = Surface area of the dome, sq. ft.  
 $ds$  = Width of square surface element of the shell.  
 $t$  = Thickness of the shell, in.  
 $T$  = Hoop force in the top rib, lbs.  
 $v$  = Shear stress in concrete, psi.  
 $V$  = Capacity of the tank, cu. ft.  
 $V_1$  = Shear force in concrete section, lbs./ft.  
 $w$  = Intensity of loading, lbs./sq. ft.  
 $w'$  = Unit wt. of water, lbs./cu. ft.  
 $W$  = Total load on the shell surface above AA including dead load, lbs.  
 $\hat{W}$  = Sum of weights of the roof dome, the wall and the weight of conical section above AA and the water above AA, lbs.  
 $W_1$  = Total weight of the bottom dome and the water above it, lbs.  
 $W_2$  = Sum of weights of the inclined section and the water above it, the weight of the cylindrical wall and the roof dome, lbs.  
 $\hat{W}_1$  = Sum of the weights of the roof dome and the wall above AA, lbs.  
 $Z$  = Intensity of pressure normal to shell surface, lbs./sq. ft.  
 $\alpha$  = Angle of inclination of the tangent to the bottom dome at the edge.  
 $\beta$  = Angle of inclination of conical section with the horizontal.

$\epsilon$  = Angle measured in the plane normal to axis of surface of revolution.

$\phi$  = Angle measured in the meridional plane.

$d\epsilon$  = Angle subtended by element  $ds \times ds$  at the center of curvature at right angles to the meridional plane.

$d\phi$  = Angle subtended by the element  $ds \times ds$  at the center of curvature in the meridional plane.

$\nu$  = Poisson's ratio for steel.

#### Abbreviations.

psi = Pounds per sq. in.

$\infty$  = Infinity

lbs. = Pounds

in. = Inches

ft. = Feet

sq. in. = Square inches

cu. ft. = Cubic feet

in.<sup>2</sup> = Square inch

$\therefore$  = Therefore

wt. = Weight

$\phi$  = Round bars

c/c = Center to center

## ACKNOWLEDGEMENTS

The writer wishes to thank Dr. Robert R. Snell, Associate Professor, Department of Civil Engineering, Kansas State University, Manhattan for his guidance, assistance and helpful comments and criticism in the preparation of the report. The writer also expresses his thanks to Professor Vernon H. Rosebraugh for his guidance in preparing the subject matter of the report during the summer of 1965, and to Dr. Jack B. Blackburn for his valuable suggestions in the preparation of the report.



## BIBLIOGRAPHY

1. Den Hertog, J. P., Advanced Strength of Materials. New York: McGraw-Hill Book Co., Inc.
2. Gray, W. S., Reinforced Concrete Reservoirs and Tanks. London: Concrete Publications Limited. 1948.
3. Gray, W. S., Reinforced Concrete Water Towers, Bunkers, Silos and Gantries. London: Concrete Publications Limited. 1947.
4. Godfrey, E., Structural Engineering Book 2 - CONCRETE. Pittsburgh, Pa.: Published by the Author. 1908.
5. Kirkham, J. E., Theory and Design of Reinforced Concrete. Michigan: Edward Brothers, Inc. 1941. 1st edition.
6. Manning, G. P., Reinforced Concrete Design. London: Longmans, Green and Co. 1924.
7. Schoklitch, A., Hydraulic Structures, Vol. I. New York, N. Y.: The American Society of Mechanical Engineers. 1937.
8. Terrington, J. S., Design of Domes. London: Concrete Publication Limited. 1951.
9. Timoshenko, S., Theory of Plates and Shells. New York: McGraw-Hill Book Co., Inc. 1940. 1st edition.

ANALYSIS AND DESIGN OF AN ELEVATED REINFORCED CONCRETE  
WATER TANK OF THE INTZE TYPE

by

BALEIR SINGH SANDHU

B. Sc., the University of Glasgow, 1957

---

AN ABSTRACT OF A MASTER'S REPORT

submitted in partial fulfillment of the  
requirements for the degree

MASTER OF SCIENCE

Department of Civil Engineering

KANSAS STATE UNIVERSITY  
Manhattan, Kansas

1966

## PURPOSE

The purpose of this report is twofold; (1) to develop the formulas for the membrane stresses in the various parts of the Intze Tank named after its inventor O. Intze; (2) to use these formulas in the design of a 200,000 imp. gallons capacity tank.

In addition to the formulas for the membrane stresses, the formula for economical tank dimensions for a given capacity has been derived using the minimum value theorem of Differential Calculus.

The formula, which satisfies the Intze condition that the resultant horizontal thrust on the ring beam supporting the tank is zero when the tank is full, has also been derived.

## PROCEDURE

The formulas for the membrane stresses in the various parts of the tank shell have been derived by the use of the membrane theory of shells of the form of a surface of revolution and loaded symmetrically with respect to the axis. The bending stresses are neglected in the design because these are very small compared to the membrane stresses.

In the solution of the numerical design example, the economical tank dimensions were determined by the use of the formula derived for this purpose. After determining these general dimensions of the tank, i.e. the height and the diameter, the rise  $r$  of the roof dome and angle of inclination  $\beta$  of the conical section were assumed. Assuming the vertical height of the conical portion and selecting the diameter of the supporting ring, the angle of inclination  $\alpha$  of the bottom dome was determined from the formula.

$$W_1 \cot \alpha = W_2 \cot \beta$$

where  $W_1$  and  $W_2$  have the notations given at the end of the report.

Then using these dimensions and the given loadings, the membrane forces  $N_\phi$  and  $N_\theta$  in various parts of the tank and hence the reinforcement required were found. For the purpose of dead weights, the thicknesses of roof and bottom domes and the vertical wall were assumed first. The reinforcement required to resist the hoop force in the rib at the junction of roof dome and vertical wall was calculated.

The concrete stresses in various parts were then checked and were found to be within permissible limits.

In the concluding part of the report, the theory of the analysis and the basis and justification for various assumptions have been discussed. From this, it was concluded that the method of analysis of the tank shell using the membrane theory of shells gives a satisfactory design.