

WORSHIP LIFEWORLD
AND
POST-VATICAN II CATHOLIC CHURCHES:
A PHENOMENOLOGICAL INTERPRETATION OF
LIGHT OF THE WORLD CATHOLIC CHURCH, LITTLETON, COLORADO

by

ROBERT DAVID HABIGER

B. Arch., Kansas State University, 1971

A MASTER'S THESIS

submitted in partial fulfillment of the
requirements for the degree

MASTER OF ARCHITECTURE

Department of Architecture
College of Architecture & Design

KANSAS STATE UNIVERSITY
Manhattan, Kansas

1988

Approved by:



David R. Seamon, PhD
Major Professor

LD
20608
.74
ARCH
1988
H33
c. 2

A11208 232652

TABLE OF CONTENTS

	page
ACKNOWLEDGEMENTS	i
1. INTRODUCTION	1
Light of the World Catholic Church	4
Examining Light of the World's Worship Lifeworld	12
Overview of Chapters	16
2. REVIEW OF RELATED LITERATURE	18
Space and Place	19
Sacred Space	21
Sacred Architecture	24
Catholicism and Post-Vatican II Architectural Space	28
3. POST-VATICAN II WORSHIP SPACES	35
Environment	37
Encounter	42
Mystery	47
Integration	51
4. RESEARCH APPROACH	53
Architectural Review	55
Architectural Recording	58
Behavioral Recording	59
Parishioner Interviews	62
Personal Experiences	66
Prospectus	71
5. ENVIRONMENT	72
Formal Structure	74
Worship Structure	86
Gathering Space	92
Quality and Appropriateness	105
Comparisons	114
6. ENCOUNTER	119
Worship Participation	121
Personal and Communal Spaces	127
Sensory Contributions	133
Movement, Gestures and Posture	142
Comparisons	152
7. MYSTERY	156
Worship and Liturgy	158
Symbols and Traditions	156
Spirituality, Reverence and Devotion	173
Comparisons	177

8. INTEGRATION182
Response to <u>EACW</u>182
Place and Community187
Design Implications194
BIBLIOGRAPHY198
APPENDIX A	
Interview quotes204

LIST OF FIGURES

Figure No	Description	Page
1	Map of Parish Boundary	5
2	Northeast View	6
3	Architects' Site Plan	7
4	Southeast View	9
5	Architects' Floor Plan (Phase 1)	9
6a & 6b	Domus Dei and Domus Ecclesiae Archetypes	26
7	Theoretical Relationships of EACW Themes	52
8	Openness and Enclosure Morphology	76
9	Street View--Building's North Wall	77
10	View of Western Approach	78
11	South Elevation	79
12	Architects' Floor Plan (Phase 1,2 and 3)	82
13	Square Topology of Floor Plan	82
14	Square Topology of Building Cross-Section	84
15	Square Geometric Pattern--South Entrance	84
16	View from East	89
17	View from Southeast	90
18a & 18b	Volumetric Form Studies	91
19a & 19b	Worship Service Arrangements	94
20	Face-to-Face Seating in Worship Space	97
21	Courtyard	102
22	Mountain Mural--Worship Space	107
23	Flag Banners at Main Entrance	109
24a & 24b	Floor Plans--Denver Circular Church	123
25	Wheelchair in Worship Space	131
26	Worship Space Behavioral Map	137
27	Parishioner Arrival from Parking Area	144
28	Behavioral Map--Movement at Baptismal Font	147
29	Tower	167
30	Courtyard Cross	169
31	Baptismal Font	172

ACKNOWLEDGEMENTS

First, I am deeply indebted to the many people at Light of the World who so willingly shared their thoughts and time during this research study. I am especially grateful to the Friedrich family--Doug, Cheryl, Donata, Nikki, Brian and Steve--who adopted me into their household and gave me hours of enjoyment and laughter. I thank them for easing the loneliness of my family.

A special acknowledgement is due to the members of the church neighborhood group who extended me an open invitation to attend their activities. I will always hold a special place in my heart for everyone in the group. They gave me much energy and inspiration throughout the summer. I thank Jerry Schopen for renting me space in his basement, which allowed me to live within the parish community. He provided a relaxed atmosphere which allowed me to concentrate on my research, writing, and reading.

Fr. John Dold provided me with intellectual inspiration and thoughtful insight. His personal support was always appreciated and helped to increase my overall dedication and inquiry.

I am extremely honored that David Seamon was my major professor for this research study. I am thankful for the directness of his reviews which helped me to always stay focused on the immediate task. His patience, guidance, and constant influence extended my understanding of phenomenological research which is extremely valuable. Thank you, David!

I thank my other committee members, Lew Seibold and Gene McGraw, for their assistance in this thesis. It was Lew's thought provoking lectures which established the roots for this qualitative inquiry. Gene provided an experiential background in the Catholic Church which gave a balance to my interpretations. I thank Margaret Boschetti and David Balk for providing much needed moral support during my thesis writing.

I am grateful to the Department of Architecture and the College of Architecture & Design at Kansas State University for the research scholarship which helped defray my photo, travel, and recording costs.

I can never repay the unselfish efforts of my wife, Lynn Ellen Doxon, who was finishing her PhD during this same time, in providing editorial review of my thesis. Without her encouragement, and love I would not had finished on time. To my sons, Geoffrey and Matthew, I dedicate this thesis. While my work sometimes kept us from seeing a movie or attending a basketball game, those moments we did spend together were special. The interest they showed toward my work was always appreciated.

* * * Toward Evaluating a Worship Lifeworld * * *

In 1963, the Second Vatican Ecumenical Council--Vatican II--originated the document Constitution on the Sacred Liturgy, which initiated a theological revision of worship in the Roman Catholic Church. One aspect of this theological renewal centered on architectural space, and the document briefly described the alterations to the worship place (Simcoe, 1985, p.33, par.128). Topologically, the post-Vatican II worship spaces advanced by the document are open, flexible, and accessible spaces in contrast to pre-Vatican II worship spaces which were closed, stationary, and unaccessable. The main focus of this thesis is to understand the essence of the new post-Vatican II worship environment. The empirical context is Light of the World Catholic Church in Littleton, Colorado, a structure designed to meet the requirements for post-Vatican II worship.

The key question I ask is the degree to which this church fulfills the criteria of a post-Vatican II worship space. Catholicism has identified these new worship spaces as places where parishioners are participants in the active celebration of the liturgical service and at the same time experience a sense of mystery. My focus is the exploration of how the physical and experiential aspects of the worship space create active worship participation. I began my

efforts to understand what the Catholic Church considers an ideal worship space with an interpretation of the current guidelines by which these spaces are designed.

Since Vatican II, the development of this new spatial topology has not evolved quickly. For fifteen years, from 1963 to 1978, the design of Catholic worship environments was in transition. This was a time of experimentation, when no clear models for the design of these spaces existed. In 1978, the United States Catholic Bishops published Environment and Art in Catholic Worship (hereafter referred to as EACW). This document provided the first official information on the planning and design of these new worship environments. EACW stated that the act of worship not only required changes to the physical space but also involved a development of a full experience of worship which would lead to a transcendent state. To understand these new worship spaces, it is critical to couple the physical qualities of the place with the experiences of people within that particular environment.

Practically, this study is undertaken through a phenomenological approach which, in part, can be said to involve a qualitative description and interpretation of people's experiences within a physical setting (Seamon, 1987). Phenomenological research examines the everyday immersion of people in their environment, a state of occurrence that the phenomenologist terms lifeworld.

Specifically, lifeworld is the unself-conscious, taken-for-granted pattern of a person's existence in a particular place. From an architectural viewpoint lifeworld is significant because it includes the relationship between people and the built environment.

For this thesis research, the focus is on worship lifeworld, by which I mean the unself-conscious, taken-for-granted immersion of people in a place of worship. This research study, therefore, focuses on the relationship of the person and built environment as occurring in a worship space. Worship lifeworld, then, became the prime focus of the research. To describe this worship lifeworld required careful description of people's experience of worship within a particular worship setting.

To explore fully one worship lifeworld in relation to EACW, I selected a recently completed Catholic Church which had been recognized as being on the "cutting edge" of liturgical design as well as for the contemporary nature of its architectural design (Dixon, 1986). This Church, Light of the World, has received design awards from the national design magazine, Progressive Architecture (Jan. 1984), Rocky Mountain Chapter of American Institute of Architects, and a National Honor Award by the Interfaith Forum on Religion Art and Architecture. Subsequent to the building's construction, the church was the feature cover article in the February, 1986, issue of Progressive Architecture. This

national attention indicates that Light of the World has an architectural significance worth exploring. The remainder of this chapter is a general description of the church and the approach taken in my examination of its worship life-world.

Light of the World Catholic Church

Light of the World Parish is located in an upper middle-class suburb of Denver, Colorado. Figure 1 is a map of the general area where the church is located. The parish property is on the south side of an east-west arterial street connecting residential areas to the west with commercial areas to the east. This street provides the only vehicle access to the property. A major north-south regional highway is one quarter mile to the east. Residential development surrounds the church property on every side except the northeast, where a small local shopping center is located. Vacant land designated for residential development exists adjacent to the parish property on the west.

This particular area of Denver is marked by its generally higher elevation. The area overlooks most of the Denver area to the east and north and the parish property is within three miles of the Rocky Mountain foothills. This combination of a higher elevation and proximity to the mountains offers magnificent views from the parish property.

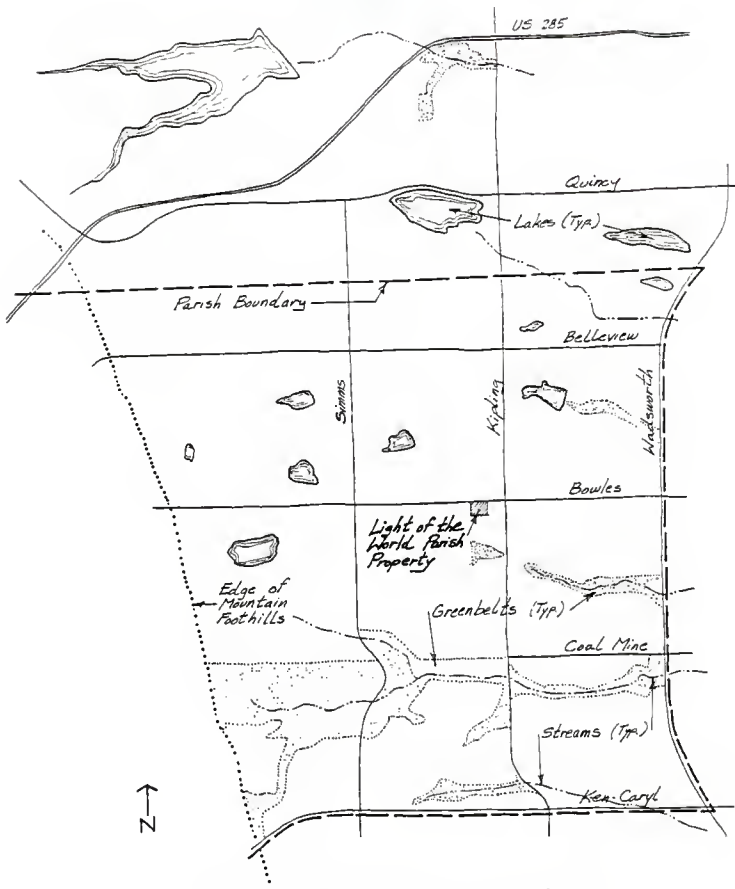

Figure 1: Map of Parish Boundary

While many church buildings are typically designed with a formal entry street elevation, Light of the World is unusual in that its formal entry is at the non-street facing building elevation. This means when a person arrives at the street elevation one encounters a solid ten foot high brick wall in which the only features seen are a geometric brick pattern, small glass-block windows, and roof forms above the wall. Figure 2 shows this view of the church as one approaches from the major populated areas to the east. The building appears elevated above street level because of the earth berm which rises from the street and covers the first eight feet of the building. This establishes a strong linear line parallel to the street. Attention, however, is captured by the varied roof forms, conical shaped stainless steel and glass skylight at the tower and the mountains in the background.

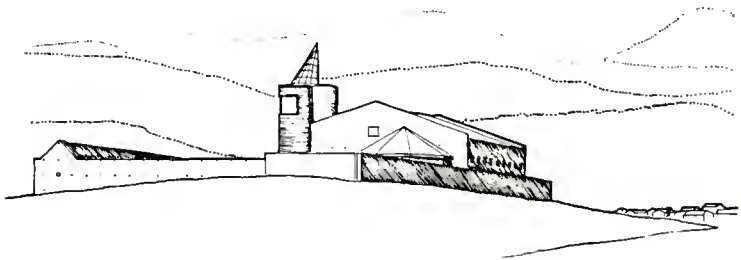

Figure 2: Northeast View

The site is organized on the same linear concept as this north elevation. Figure 3, the architects site plan, illustrates how the building, lawn area, and parking area all create strong linear statements which run east to west across the entire site. The church building is located at the northern edge of the property, the highest elevation on the site. The site slopes gently to the south property line which places the parking area at the lowest elevation. The overall linear design may reflect an association with the natural landscape, which has natural elements of streams, lakes, and greenbelts positioned predominantly in an east-west direction (refer to Figure 1).

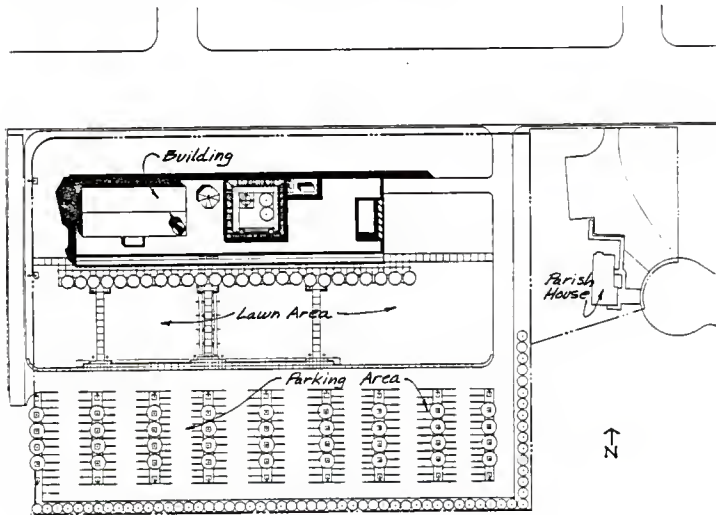

Figure 3: Architects' Site Plan

In establishing this site organization, the architects developed a formal entry plan having a single main entrance at the south building elevation. The landscaped lawn area located between the building and parking helps to extend the axial pedestrian path and centers people with the building entrance. The resulting entry movement allows people time to view the highly geometric composition of the building. This geometry is formalized through the use of four-inch square red bricks inserted within a beige brick facade on a four foot grid.

Along with the brick pattern, a person's attention is drawn to the door and window colonnade and the vertical tower. Figure 4 illustrates a view of this linear open colonnade which lightly supports the building's upper wall and roof form. This horizontal image, however, is punctuated by the vertical tower whose juxtaposition of square and circle forms establishes a major orientation point.

The one-quarter conical stainless steel skylight, the most visible element of the building, is located at the intersection of the square and circle. Attention is also drawn to the tower because of its brick color. In opposition to the front facade, the geometric grid is now composed of four inch square beige bricks within a red brick background on the same four foot grid. This pattern occurs only on the square portion of the tower leaving the circular form beige in color and free of any pattern.

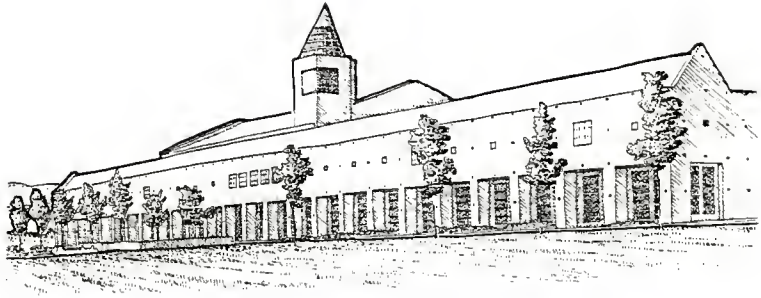

Figure 4: Southeast View

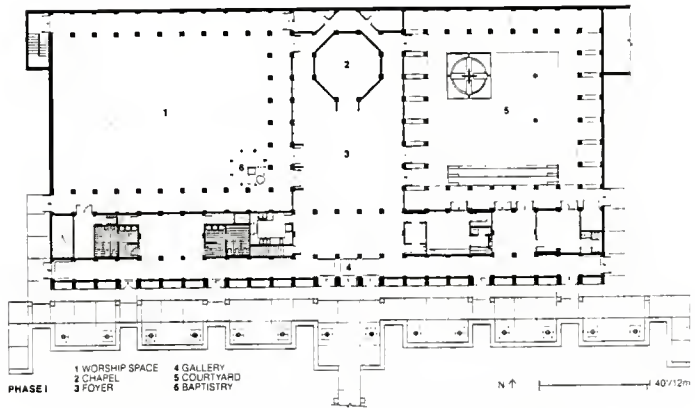

Figure 5: Architects' Floor Plan (Phase 1)

In plan, the building consists of rectangular and square spaces organized on an eight foot cardinal points grid. Figure 5 shows the architects floor plan which locates the principle spaces of the building. Farthest to the west is the worship space, the principle space in the church structure. To the east are the foyer, eucharistic chapel, and courtyard, each systematically following the modular pattern established by the grid.

The connecting element for all these spaces is the linear gallery. It acts as a horizontal path from which all spaces extend. The gallery is a critical design element which not only created the rhythmic entrance elevation on the outside but also is the organizational backbone of the building's interior spaces. Inside the repeating door and window openings plus roof trusses extends the space horizontally bisecting the mountains to the west and sending ones vision to the city in the east, thus, establishing a formal connection to the region.

From this gallery one moves through the foyer, a non-worship gathering space, to the eucharistic chapel, courtyard, or worship space. The architectural program stated that flexibility in the use of these spaces for a variety of parish activities was a prime objective. The worship space meets this objective through the use of movable seating and sanctuary furniture. The congregation sits in folding upholstered chairs rather than the more

traditional wood pews. This flexibility allows the worship space to be reconfigured four times a year in direct response to the Catholic Church's liturgical calendar. This quality, while not contemporary in its roots, is counter to more traditionally designed worship environments.

Color and light are also significant experiential elements of the worship space. The worship space is very bright with natural daylighting admitted through clear glass-block clerestory windows. The wall surfaces are warm beige in color which provides a high surface reflectance to support this brightness level. The carpeted floor is a darker neutral beige color and, as a contrast, the wood plank ceiling and trusses are a rich orange ocher color. The upholstered parishioner seating is a muted turquoise color. The altar furniture is a dark cherry wood resting on natural oak platforms.

The only fixed element in this worship space is the baptismal font and supporting tower structure. The baptismal font together with the tower structure provide a key orientation to the worship space. The font itself is made from an indigenous granite boulder cut to create a baptismal water basin at its center plus allowing water to flow down its sides. Natural light coming from the tower's skylight and clerestory windows makes this area brighter than the worship space.

While the general architectural form for the worship

space can be typologically labeled basilica church, the method of combining materials in a rhythmic geometry is distinctly contemporary in nature. Additionally, the spatial topology of ancillary spaces surrounding the worship space effectively hides this basilica image. While the geometry of the building is important in establishing an identity for the building, it is principally the spatial topology, rather than the building's formal style, which created key person-environment relationships.

Examining Light of the World's Worship Lifeworld

To examine this recently completed church, I used five parallel methods to describe the physical and experiential attributes of the worship lifeworld. This multifaceted approach was designed not only to describe the physical environment, but also to describe how people experienced their worship lifeworld. A key consideration was, therefore, in formulating a way of seeing this phenomenon from several points of view. One can think of this approach as similar to how viewing a sculpture from different points of view will develop a greater comprehensive understanding of the sculpture than if the sculpture is viewed from one position only. Similarly this multifaceted research approach was organized to create multiple opportunities for understanding the worship lifeworld.

I conducted my research study over a two-month period in the summer of 1987. I lived in the parish and attended as many of the worship services and parish activities as possible. I also participated in a neighborhood church community group which met weekly. Through these associations I was able to meet a wide variety of individuals, from whom I received information concerning the parish and in particular the worship space. Formal interviews with twelve parishioners, pastor, associate pastor, and architects took place during this same two month period. It was through these interviews that information concerning Light of the World was acquired for comparison to the qualities expressed in EACW.

A detailed review of EACW established the manner for exploring the worship lifeworld present at Light of the World. This review is discussed in chapter three. The interpretation of EACW established that three major themes represent the ideal Catholic worship lifeworld. First, environment describes that a place is needed to physically gather for worship. This gathering place is said to best serve the faith community when it is a hospitable environment. Second, encounter establishes the need for human interactions to occur in the worship space. The use of sensory, movement, word, memory, and reflective experiential qualities are inherent to creating the interactions of worship. Third, mystery recognizes the transcendent qualities

of wonder, awe, and contemplation which are necessary for a worship space.

These three themes became the major organizational vehicle around which to structure this research study. The physical and experiential qualities of each theme, as occurring at Light of the World, was compared to these three major themes. The avenue of inquiry into Light of the World's worship lifeworld was to first explore the physical and experiential attributes. The physical examination occurred through architectural review and recording processes. The experiential examination occurred through behavioral recording, parishioner interviews, and personal experience processes.

It was generally found that Light of the World, while having a rigid geometric pattern, provides for the physical elements said to be necessary in the ideal worship environment. These physical attributes include a simple one-room space that through the use of movable seating and sanctuary furniture provides a flexible gathering space for the worship assembly.

Experientially, the building's design enhances the development of worship encounter and provides opportunities to meet people of the parish in non-worship gathering spaces. The amount of group experiences within these non-worship and worship spaces is a critical element in the development of parish community. There remains a concern,

however, that the building's openness does not provide for an individual's need for private worship space.

The most fundamental issue became the fact that wonder or transcendence is sometimes missing in a person's experience of worship at Light of the World. At other times this quality was profoundly present. This polarity of worship experiences relates more to the sociological nature of parishioner involvement in the liturgy, rather than the physical qualities of the worship space. There does exist, however, a desire to introduce more liturgical art and ornamentation into the worship space. It is the almost total lack of liturgical art which appeared to be the greatest missing link in a person's feeling of God-consciousness.

Light of the World should be considered a design in transition. Clearly it puts forth a new image as to what constitutes a post-Vatican II Catholic Church. This does not mean, however, that it represents the best or final solution. There is a contemporary character to the building that sits well with the upper-middle class progressive society found in this area of Denver. Located in a more conservative Catholic community, this building would surely meet with high resistance.

Overview of Chapters

Chapter two provides a review of space and place, sacred space, sacred architecture, and sacred architectural space within the Catholic Church. First, the chapter considers how people experience space and place. Next, sacred space as wholly different from non-sacred space is explored. The review then focuses on the issue of sacred architecture and describes two specific archetypes associated with places of worship. The chapter concludes with a discussion on sacred architectural space in the Catholic Church.

Chapter three is an interpretive review of the United States Roman Catholic Church document EACW, which provides the current design guidelines used in the development of post-Vatican II worship spaces. From this interpretation of EACW, I identify three major themes which is considered to be the ideal qualities in the design of post-Vatican II worship spaces. These three themes--environment, encounter, and mystery--provide an interconnecting triangle of physical and experiential attributes which develop a full experience of worship.

Chapter four describes the research approach used in the thesis. With the concern of retaining a reliability and trustworthiness in the research, five separate research techniques were employed. This multifaceted research approach allowed for the exploration of both the physical

and experiential qualities of the worship lifeworld. The chapter describes how these five avenues of research provided a comprehensive examination of the person and built environment relationships.

Chapters five, six, and seven discuss each theme's physical and experiential qualities as found at Light of the World. The development of the chapter sections arose from information provided by parishioners during the interview and observation research processes. The major characteristics of each theme was then contrasted and compared with the considered ideal document, EACW.

Chapter eight draws together the major issues found in each of the preceding three chapters. A synthesis of Light of the World's worship lifeworld is developed, which leads into a discussion of design implications and future directions for the development of post-Vatican II worship lifeworlds. The critical issues raised indicate that architects must work for a thorough understanding of both the physical and experiential aspects of the new post Vatican II Catholic worship lifeworld. To ignore these issues might mean future design solutions would be based upon outdated spatial patterns of worship.

* * * Place, Sacred Space, and Architecture * * *

One way to approach phenomenological research is to explore and describe the experiences which take place in the person-built environment (Seamon and Nordon, 1980). Tuan (1986) stated that to describe any environment completely we must combine inputs from both the physical and the mental world. To understand places we need to study not only qualities of architecture and space, but also the human experiences associated with that space (Harries, 1983). Each of these elements--the built architectural environment and human experience--are intertwined. Not looking at one would diminish the validity of any response derived from the other.

A focus for phenomenological research is to study lifeworld, which can be defined as the unself-conscious, taken-for-granted pattern of a person's existence in a particular place (Seamon, 1980, p.149). A lifeworld of worship would consist of the unself-conscious immersion of people in their worship space. To describe a lifeworld is to examine the space that surrounds people as well as their movements, gestures, and behavioral experiences. Lifeworld then, can relate to a particular group of people in a particular setting.

To explore worship is to examine the act of celebra-

tion, looking at the ritual and liturgy of a service. Worship, therefore, can also relate to a particular group of people in a particular setting. To describe worship lifeworld then, is to examine the worship space that surrounds people as well as the movements, gestures and behavioral experiences that occur in the worship environment. Importantly, how people dwell within this particular worship lifeworld will establish an "identification" between place and the people (Norberg-Schulz, 1985, p.16).

Space and Place

A beginning point in understanding worship lifeworld is the phenomenological research of space and place as experienced. Relph (1976) provides six dimensions of spatial environments. His classifications move from primitive space, which invokes a basic unconscious response to space, to abstract space where we have no foundation but only theory about space. These six classifications define a continuum along which one can identify different levels of spatial experience.

Tuan (1974a, p.215) says that the combination of human experiences such as vision, touch, movement, and memory gives a person a characteristic "sense of place". However, he reminds us that we do not perceive space in isolation. We can have not only "personal experiential space" in which

we perceive space around us, but also "group experiential space" in which we relate to space in response to the presence of other people (Tuan, 1974a, pp.224,228). It is all these experiences in a space that provides connections for determining the meaning of a particular place (Relph, 1976).

To study place is to focus upon one component of lifeworld. Relph (1976, p.43) states that we unconsciously define place as a "profound centre of human existence". We derive our meanings of a particular place from our experiences with that space. Relph (1976) defines these experiential responses to place as being dependent upon location, the built environment, our perception of that environment, and the interactions between spaces and people, but also on time and experiences within that space. Therefore, each person will have a different experience of place and being-in-the-world. People develop deep associations with places in which they live because these spaces define our daily human existence. Places are remembered not only because they are different, special, or unique but also because they stimulate and give us memories to which we then attach associations (Bloomer, 1977).

Tuan (1974a, p.234) states that a place derives meaning because people give the place a "greater emotional charge" than is justified by location or function. He labels these types of spaces as significant places. He provides a

classification for these significant type of spaces: (1) a place can be a "public symbol", with a physical form that commands attention and has high image to the people of the community, and (2) a place can be a "field of care", which evokes affection from the people and does not need to display an outward image to a community (Tuan, 1974a, p 236).

To develop an "authentic" sense of place requires belonging to that particular place, or being "inside" that place, without conscious reflection (Relph, 1976, p.65). An example of this type of place experience is a person's home, which usually represents an extreme insiderness. This is labeled as an "existential insiderness" (Relph, 1976, p.55).

For a worship lifeworld the sense of place will derive from both personal and group interactions. How this may affect the relationship of insiderness to outsiderness of being a public symbol or field of care is a major question for this research. What type of connecting associations people develop and what meanings they derive from their worship environment become important questions as well.

Sacred Space

In The Sacred and the Profane, Mircea Eliade (1961) describes sacred spaces as "qualitatively different" from other spaces. He establishes two wholly different spatial

patterns for the religious person. Sacred space which is "strong significant" space and profane space, which is without "structure or consistency" (Eliade, 1961 p.20). Eliade (1961) suggests that sacred space is positive space while profane space is negative space. Realistically, this is too great a distinction. A space is neither completely positive nor negative but varies according to specific experiences of that space. This does not mean that sacred or profane spaces do not exist, only that the difference between sacred and profane space exists in our ways of viewing and interacting with "space and time" (Hellwig, 1972, p.48).

Another approach to sacred space says that a person has a ritual orientation of being in the center of the world (Turner, 1979). Sacred space in this sense is being centered towards that place (Eliade, 1961). For Eliade (1961), this centeredness is generally delineated as a vertical dimension, or axis mundi, connecting heaven to earth. Eliade (1961) also suggests this centeredness becomes a symbolic center of the world wherever sacredness manifests itself in a place.

This view allows each worship environment to potentially have an axis mundi or heavenly connection. Turner (1979, p.21) says that this ability implies a "centre of reference" for a sacred place and exists as a physical orientation to that place which then develops the feeling

that the place has become a meeting place between heaven and earth. Norberg-Schulz (1980), makes reference to this same concept when he says that a horizontal plane which is pierced by a vertical axis represents a foundation for the Christian church.

While sacred space is seen to exist most concretely in a religious structure, sacred places are not limited to spaces developed just for worship. Sacredness, which establishes a sacred place, occurs where there is the feeling of "hierophany," meaning that something sacred has shown itself to us (Eliade, 1961, p.11). The phenomenological view is that many different things can represent a hierophany through the power of a religious experience. A built form may facilitate our having a religious experience, but being located in an architectural space does not mean that a religious experience will necessarily take place.

Sacred space is different from other spaces because it creates different feelings in us, or because a space becomes special in the image of the people using that space. As an example, for some people the wilderness is a sacred place because people perceive the wilderness as a special place (Graber, 1976, p.8). So, too, we define certain spaces as being a special or a "charged" place where powerful feelings have been triggered within us (Brill, 1986, p.9). To Tuan (1974a), a special place is one in which a close contact with a place occurs. That which makes a place special grows

out of each persons varied experience and feelings of specialness. Therefore, a broader underlying base of experiential meanings exist that makes connection with the physical space.

A key research question is how to develop a meaningful interpretation of people's experiences in a particular worship setting. Supporting this view as it relates to worship environments, Engel (1985) says that sacred space should be studied by describing human experiences and their relationships to a spatial environment. He says that the focus is not upon just the physical elements of walls, ceilings, and floors that create a worship space but also on the person and how they experience this space. This phenomena is a balance between the qualities of the architectural space and the way people develop an ongoing experiential memory of that space.

Sacred Architecture

The title sacred architecture is used to define buildings that have been constructed for worship. Turner (1979) states that the worship structure must be seen as the physical expression of a spatial pattern used in worship. He defines two distinct types of worship spaces--"temple" and "meeting house"--as having different spatial characteristics (Turner, 1979, p.11).

The temple is representative of the archetype that Turner calls Domus Dei--House for God (Turner, 1979, p.42). One example of the temple type, according to Turner, is the Church of the Latter Day Saints at Salt Lake City, Utah (Turner, 1979, p.46). The grand scale of this church is typical of the cathedrals in use by the Catholic Church during the Middle Ages. These cathedrals, large in scale, cruciform in plan, with spatial patterns that separated deity and laity were integral to the Roman Catholic Church for over 1500 years. The worship space in this temple archetype stood separate from other spaces and represented a need for order and stability in the church during that time (Debugst, 1968). The liturgy occurred as a ceremony and not as a celebration in which most of the space was for spectators watching the ritual that was taking place.

Turner also speaks of a second, contrasting architecture that he calls Domus Ecclesiae--House for the People of God (Turner, 1979, p.11). He states that this archetype represents the authentic expression of the Christian tradition, which in comparison to the temple archetype "has no special sanctity" (Turner, 1979, p.153). Turner (1979) gives the earliest example of this type of space as the domestic house used for worship during the first century of Christianity and he gives the term meeting house to this archetype (Turner, 1979). Conceptually, domus ecclesiae can be referred to an archetype of gathering space.

The spatial patterns typical of this archetype are organized as a simple room providing a shelter in which the liturgy occurs (Diekman, 1980). In this archetype the spatial patterns have shifted so that the sanctuary space is within the parishioner space. This fundamental change essentially creates the sense of gathering within the worship space. The Catholic Church also sees this change as referring back to the early 1st and 2nd century Christian assemblies which met in houses (Diekman, 1980). In contrast to the previous archetype, this spatial pattern does not separate spectators from the ritual ceremony, but places people in the ritual space as participants in the worship celebration.

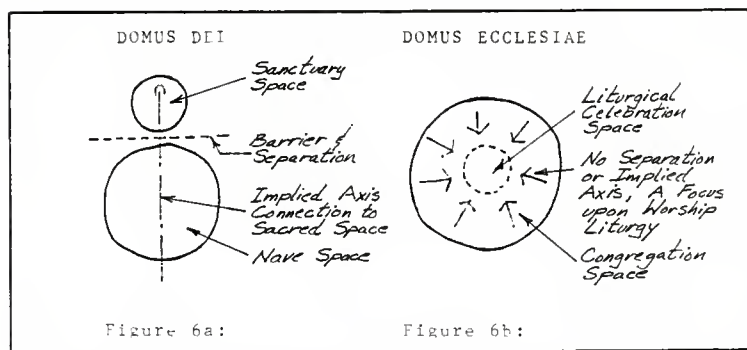

These two contrasting spatial patterns can be conceptualized as shown in figures 6a & 6b. Figure 6a represents domus dei--House for God. With this temple archetype the spatial patterns are organized whereby the parishioners in

the nave space are physically as well as psychologically separate from the sanctuary space where the ceremony takes place. A typical spatial arrangement for this archetype is a long nave with the sanctuary space located as a terminus. Within those Catholic Church's exhibiting these spatial characteristics, the communion rail reinforced this separation as well as restricting laity's access to the most sacred space. The idea of the sanctuary's sacred importance was further bolstered through the greater amount of ornamentation contained in the sanctuary, reaching a crescendo at the high altar.

Figure 6b represents domus ecclesiae--House for the People of God. With this meeting house archetype the spatial patterns have shifted so that the sanctuary space resides as a part of the parishioner space. The laity are not separated physically from the space where the ritual ceremony takes place. This fundamental change provides for the sense of gathering within the ceremony space. Now, instead of an implied axis in which a path exists to reach the sacred space, the total space is a balanced focus between the liturgical ceremony and the people who come to celebrate. The main church space no longer consists of two distinct and separate spaces but as a singular worship space.

One recent view of how this new worship space is to be designed comes from Sovik's (1973), Architecture For Wor-

ship. He suggests a need to return to an early type of non-church, stating that such spaces are not built as temple type of spaces. His title for this new worship space is "Centrum", which is a room "secular" in character that "shelters" the assembled people (Sovik, 1973, p72).

While I agree that the worship environment needs to be a meeting place for the people, I am concerned with his argument that such a place needs to be designed exclusively as a secular space. My question becomes, how can such a secular room become special, and therefore potentially sacred, if it is designed exclusively as a multi-purpose space? An example is a parish that developed such a centrum type of space in the late 1960's that has now replaced the centrum space with a new building which is designed for worship rather than for secular activities (Ciferni, 1987). A key aim of this thesis is to demonstrate how architectural sacred space is being interpreted in the Catholic Church, particularly in terms of present liturgical design guidelines.

Catholicism and Post-Vatican II Architectural Space

In 1963, Vatican II--a worldwide meeting of Catholic Bishops--produced the document Constitution on the Sacred Liturgy. This document did not indicate directly that an archetypal shift to domus ecclesiae was to take place.

Rather, it initiated a dialogue in the Catholic Church which eventually identified that "domus ecclesiae--house of the church", where church is defined as "the faith community", is the appropriate new worship archetype (Bishops Committee on Liturgy, 1978, p.18). This indirectly relates to Turner's definition of domus ecclesiae, which will be discussed later in this section.

Before Vatican II, the basic experience of a worship space was individual worship, fixed orientation, and spatial separation of the congregation from the sanctuary space. After Vatican II the experience of worship is seen to be personal and communal occurring in a flexible open orientation, with direct connection to the sanctuary space (Malarcher, 1978). This transformation meant that people become involved as participants rather than being spectators (Allen, 1978).

Vatican II reviewed and questioned many aspects of the Catholic Church within a concept of spiritual renewal. Out of this theological redirection have come new spatial relationships for worship environments. From this renewal new considerations of issues such as human experience in worship were brought forth. The United States Roman Catholic Church stated that worship should not be "purely religious or merely rational and intellectual exercises but also human experiences calling on all human faculties: body, mind, sense, imagination, emotions, memory" (Bishops

Committee on Liturgy, 1978, p.8). The physical characteristics of the space which is to accommodate this change are important, with the Catholic Church describing the new worship space as a gathering space in which the complete assembly of people participate in the action of the liturgy (Fitzer, 1974).

Immediately following Vatican II, the change in worship space was being described as a change in general atmosphere, an "ethos", as defining a spiritual renewal that "would recover the true sense and reality of tradition" (Bouyer, 1967, p.2). Ideas as to how this new atmosphere was to be architecturally conceived was very limited. The most popular theme being suggested called for a "theology of the assembly", where the primary quality of the space was a house character (Debuyst, 1967, p.55). Early architectural design examples of this new assembly space were provided in Church Architecture and Liturgical Reform (Filthaut, 1968). The designs illustrated in this book, however, detailed modern-contemporary exteriors enclosing the old archetype domus dei.

Attempts at defining this new environment sometimes centered upon providing proper new decoration for the church, so as to create a "visual experience" which would establish a positive worship environment (Notebaart, 1974, p.12). Further extension of this theme led to the idea that the space where the people gather in worship is the most

powerful visual element (Fitzer, 1974).

The concern was to find a genuine way for people to gather in celebration. This new architectural space was described as "congregational space", similar to a Quaker meeting house (White, 1978, p.62). White (1978) raised concerns that two major problems existed for Churches before a new type of worship typology could be developed. First, typical assembly spaces with pews would cause too much restricted movement. Second, the typical passive way of celebrating needed to change so as not to lose experiences of smell, taste, and touch (White, 1978). Mossi (1974, p.11) listed two additional important qualities of "proximity" and "visibility" as necessary for attaining a full worship experience.

In 1978, the United States Catholic Bishops published Environment and Art in Catholic Worship (referenced as EACW in the future). This document is the result of fifteen years of intense dialogue and is currently the only ideal for judging post-Vatican II Church designs. EACW argues that the assembly space, as the most important space, is a special place becoming "quite naturally a reference and orientation point" for the faith community (Bishops Committee on Liturgy, 1978, p.25).

Turner (1979) uses the term domus ecclesiae to describe the meeting house archetype as the house for the people of God. EACW states that the building which houses the worship

celebration is called domus ecclesiae, which is defined as the house of the faith community. This similarity is important for understanding the post-Vatican II worship space.

EACW emphasized the archetypal shift to domus ecclesiae by describing how the worship environments should be a place for human interaction and active participation, a place where people are brought together "so that they can see and hear the entire liturgical action", and a place that "helps people feel involved and become involved" (Bishops Committee on Liturgy, 1978, p.16). Further discussion of EACW, which is the current guiding text for the design of these new worship environments, is provided in chapter three.

After EACW, authors have tended to discuss "aesthetic ritual experience" which deals with enriching the worship experience through "images, symbols, stories, and ritual action" (Collins, 1984, p.331). However, there is no clear understanding of how to combine these new images and actions with new worship environments.

Developing a sense of community has been a major goal in the post-Vatican II Catholic Church. Hillard (1980) stated that the action of coming together as an assembly in this new liturgy would create a deeper sense of community. Worship environments have been described as "a combination of place and active experience" (Mauck, 1987, p.84). This shift, however, was presented not as a change in architec-

tural space but as a process in developing a Christian community. In an architectural solution, the idea was to provide "non-worshipping gathering spaces" as the means to community spirit and interaction (Ensmann, 1984, p.31). This concept of developing community through interaction after the service, however, disregards any potential community development attained from the worship environment.

The study of worship lifeworld needs to be explored within a framework of the person-built environment relationship. One of the few examples of such exploration is Schlichting (1983), whose article "Holy People Make Holy Places" questioned whether new worship environments with their new decor and arrangements really influenced the way people participated in the liturgy. Her concern was to understand what was being constructed and how spaces affected people's worship experiences. She questioned the ineffective methods of involving parishioners in the design process of building a church, stating a real lack in the development of parishioner ownership. Such ownership was said to come from the church community's access to the planning, creation and decoration of the worship spaces (Schlichting, 1983, p.34). She felt that the most important issue for designers was to ask whose gathering space they were designing.

There is currently limited knowledge concerning the relationships of worship spatial patterns and their contri-

bution to active participation, interaction, and a fullness of sensory experience. Further, connections between the physical and experiential qualities of the worship lifeworld as an insight into the dynamic qualities of the worship environment are not generally available.

To understand these physical and experiential qualities of the post-Vatican II Catholic Church it was necessary first to examine the document EACW as thoroughly as possible. This document, less than ten years old, represents the Church's current principles for the design and planning of new post-Vatican II worship spaces. In interpreting this document, three major themes were found to represent the connection between person and built environment within a worship lifeworld. These themes are environment, encounter, and mystery. The following chapter will define these themes as they are derived from EACW. These themes became the major interpretive structure for evaluating Light of the World.

* * * Identifying a Conceptual Framework * * *

Typically, the term worship establishes a mental set of physical properties which a person use to define a place of worship. Such places are generally classified as a church. In this thesis I will use the more academic notation of sacred architecture. As reviewed earlier, in chapter two, the study of architecture as well as sacred architecture is the study of physical and experiential qualities. I have established that one approach for interpreting a worship lifeworld is to look at both the physical and experiential qualities the worship environment. A key question, however, is how to look at this lifeworld and, specifically for this research study, how to examine the worship lifeworld of the post-Vatican II Roman Catholic Church.

My approach is to focus upon the 1978 publication Environment and Art in Catholic Worship (EACW), which is the current written text which articulates the ideal aspects of this worship lifeworld. This document represents the Church's guiding principles, similar to an architectural program, for the design and planning of new, post-Vatican II worship spaces. Just 107 paragraphs in length it provides a thorough description of how people and the built environment are both important in the development of these spaces.

I use the document as a base from which to establish a conceptual framework for examining the worship lifeworld of Light of the World. As I interpret EACW, three major themes exist which define the new worship lifeworld. These three broad themes --environment, encounter, and mystery--are the basic ingredients of the ideal worship lifeworld. They represent what I believe to be the key elements necessary to create a worship environment which the Catholic Church says needs to be "the gathering place" of the church community (Bishops Committee on Liturgy, 1978, p.29).

For this thesis, each theme became a guide from which to judge the worship lifeworld setting of Light of the World. These guidelines were used as a reference to support or contradict the physical and experiential qualities found in the actual setting. I was interested in how these physical and experiential qualities found at Light of the World would fit into each theme.

It would be expected that different proportions of these qualities, as they exist within each theme, would occur in a worship lifeworld, even though the ideal would have equal proportions of each theme. EACW was reviewed to find the most ideal physical and experiential aspects of each identified theme. This chapter summarizes my interpretations which became the major framework around which I conducted my analysis of Light of the World.

Environment

The first theme, environment, I define as the place of worship having specific physical and spatial characteristics inherent to worship spaces. As a space it is, first, where people of the parish assemble for worship. EACW describes this space as a place in which "the action of the liturgy," or worship celebration, happens (EACW, #24₁).

Physically, the worship space is no longer defined as having a narthex, nave, and sanctuary but as a space in which the assembly of believers come together. EACW states that this place of assembly is called domus ecclesiae--house for the faith community (EACW, #28). The spatial pattern for such a space is a simple room, which semi-directly relates to Turner's (1979) archetype of meeting house or gathering space, as discussed in chapter two.

Absent from EACW is a reference to any specifically defined physical elements. Instead a generalistic view of what is required to accommodate the liturgical celebration is made. The document, in describing this general worship environment, issues a call for "a space, a place, a hall or a building for the liturgy" (EACW, #39). This request does, though, effectively void any complex or hierarchical design by asking instead for the design of simple places of worship.

¹ The use of # designates the paragraph in EACW from which the statement, quote or thought is taken.

The primary design focus is the people who assemble. EACW states that nothing "is more important than this assembly of believers" (EACW, #28). This conviction penetrates more deeply than just requiring enough space to accommodate a certain number of parishioners. At issue is design style and aesthetics of the worship space. EACW describes that the church building is to be the "shelter or skin" covering the worship space which, importantly, "does not have to look like anything, past or present" (EACW, #42). Even more specific to establishing a new physical typology, EACW states that this building must not "seek to impress, even less to dominate" (EACW, #53). Rather, what is important is the "sense of human scale" and a "sense of unity" (EACW, #53). These statements are the very essence of the domus ecclesiae archetype.

The expectation for spatial unity and more intimate scale strengthens the concept of providing a simple gathering place for people of the faith community. Historical reference is used to support this call for such spaces. EACW states that evidence indicates the earliest known Christian worship spaces were designed as "general gathering spaces" (EACW, #29). To return to these type of gathering spaces is to return to a simpler and less ornate architectural setting.

The study of the environment must also include spaces which are directly connected to the worship space. EACW

mentions that these spaces, such as a foyer or other "adequate gathering places", should be planned to create a "convergence of pathways to the liturgical space" in order to encourage introductions and conversations (EACW, #54). These non-worship spaces are said to be important because they can expand "community spirit" among parishioners (Ensman, 1984, p.31).

Experientially, a key concept of the environment theme is the concern for hospitality. EACW states that liturgy "flourishes in a climate of hospitality" (EACW, #11). Hospitality includes the need of people to feel comfortable with each other, to see each other, to see the ritual focal points, to have mobility, and to be seated together as one assembly (EACW, #11). Further, the document says a hospitable worship space as needs "a sense of oneness, of wholeness" which gives a space "integrity" (EACW, #53).

EACW discusses an "integrity" through "quality" and "appropriateness" in the architecture and art of the worship environment (EACW, #19). This idea of quality and appropriateness is applied to all the art forms--be they architecture, art, music, dance, or furniture design (EACW, #20). This concern for quality and appropriateness exists both physically and experientially. Not only do the physical elements need to have these qualities, but the experience of the worship environment needs to be based on quality and appropriateness. This concern for integrity brings up the

issue of authenticity.

Dovey (1985b, p. 46) defines authenticity as "a condition of connectedness in the relationship between people and their world". He further states that authenticity refers to an "integrity" which occurs in the person-built environment relationship (Dovey, 1985b, p. 47). Experientially, then, the theme environment is expressing the need for an authentic building structure which contributes to an authentic experience of worship.

EACW refers to this authenticity as a factor of quality and appropriateness in all parts of the liturgical celebration. Quality is perceived only by "contemplation, by standing back from things and really trying to see them, trying to let them speak to the beholder, thereby, making connection between person and art form" (EACW, #20). Quality is said to come from the love and care given by the artisan, the honesty and genuineness of any material as well as its form, color and texture (EACW, #20).

Appropriateness expressly rules out "anything trivial, and self-centered, anything fake, cheap or shoddy" (EACW, #22). These distinctions have not always been fulfilled, as new churches exist in which imitation materials are used, such as plastic laminate that looks like wood, as well as mass-produced liturgical articles, cheap plaster statues, and furniture that has a machined rather than hand crafted look. EACW states that appropriateness exists in two

forms. First, the work of art must bear the "awe, reverence and wonder which the liturgical action expresses". Second, the art, architecture, music, and other art forms "must clearly serve (and not interrupt) ritual action" (EACW, #21).

Therefore, these two elements--quality and appropriateness--call for a sense of "transparency" in which the elements of the worship environment are not only seen and as real physical objects but also experienced through a sense of reverence and mystery (EACW, #22). These are important considerations for any Christian worship lifeworld.

In summary, environment is calling for a place designed to meet the spiritual needs of the faith community which gather in worship. This assembly space, while a simple space with a less dominant human scale, should retain a sense of awe, reverence and wonder in connection with the gathering people who are the primary symbol of the liturgy. Experientially, the worship environment becomes appropriate when it provides a climate of hospitality to all who gather.

A sense of being liturgically correct comes from the authenticity of the art and architecture of the worship environment. An important aspect of this theme is the connectedness between the physical qualities of the space and the people who gather in the worship space.

Thus, according to EACW, environment exhibits the following key characteristics:

- * The worship location is referred to as the gathering place of the faith community or assembly.
- * This gathering place best serves as a worship space when it is a simple less ornate worship space, while retaining its sense of wonder.
- * Such a space supports the assembly when a climate of hospitality exists for all who gather in worship.
- * A hospitable worship environment is not superficial but has integrity with a sense of wonder, which is said to derive, in part, from the quality and appropriateness of its art and architecture.

Encounter

The second theme, encounter, I define as directly referring to human interactions or involvement with the worship lifeworld. The ways in which human experience is affected by the environmental setting are important to this issue. EACW states that to achieve this human interaction "the whole person" needs to be involved in the liturgical celebration through all their "human faculties of body, mind, senses, imagination, emotions and memory (EACW, #5). These types of human encounters, using our complete self, form the basis for this theme of encounter.

EACW states that worship experiences reach a fullness when they occur in a properly housed environment (EACW, #24). The primary concern is for a physical space where

people can assemble as one group. Strong emphasis is placed upon both individual and group worship experiences within the assembly space. This relates directly to Tuan's (1974a) personal and group experiential space where people experience space not only through their own perceptions but also in response to how other people are experiencing that space. EACW describes this as a "personal-communal experience," which they state is one of the most necessary concepts for good liturgical celebration (EACW, #16). EACW reinforces this primary concept in stating that, "the most powerful experience of the sacred is found in the celebration and the people celebrating" (EACW, #29). This, therefore, expresses that full worship experiences come not from just individual worship experience, but through communal worship with other members of the faith community.

Full participation of those assembled comes from the ability to have eye contact, to hear and to be close to the liturgical celebration. Visibility, audibility and proximity within the worship space is of concern. EACW lists these requirements as a factor in the relationship of people to the ritual action and with equal importance, as relationships between people of the assembly (EACW, #49).

EACW states that if the common assembly of believers are in close contact with each other, full participation is enhanced (EACW, #58). This physical arrangement which encourages direct people to people encounter, is said to

produce an "attentiveness" which "is part of one's share in the life community and something one owes the rest of the assembly" (EACW, #58). These ideas further reinforce the personal-communal experience. Examples of spaces not meeting these criteria are those that allow people to worship anonymously.

The encounter theme, however, is fundamentally grounded in words, gestures, movements, and sensory experiences derived from the worship celebration. EACW identifies that as participants in the worship celebration you "should be able to sense something special (and nothing trivial) in everything that is seen and heard, touched and smelled, and tasted in liturgy" (EACW, #12). No room is left for only partial compliance, as that diminishes a total human experience.

The means for achieving this experiential completeness are through variations within a liturgical celebration which stimulate encounter within the worship lifeworld. The natural repetition of Catholic worship has a "rhythm and pace" which "alternates between sound and silence, speech and song, movement and stillness, proclamation, word and action" (EACW, #25). It is precisely because one uses a continually varied combination of senses, reflection, and memory that a deep encounter with the worship space is produced.

While physical-experiential encounters occur to each

individual, an aspect of commonness between the assembled people also exists. Not only does there now exist a common language of the service, but worship occurs under conditions of a "common place, common furnishings, common art forms and symbols, common gestures, movements and postures" (EACW, #55). These common worship experiences strengthen a feeling of insiderness, which results when people more fully make connection to a place when they have reoccurring experiences (Relph, 1976). It is these commonalities which support a rich experiential worship lifeworld.

One common experience is posture. According to EACW, common posture is correct only when it is not a "forced uniformity" yet accommodates certain common postures of sitting, standing, and kneeling (EACW, #57). EACW states that "gestures done in common ... which are broad and full in both a visual and tactile sense, support the entire symbolic ritual" of the celebration (EACW, #56). Movement is another element that creates common experiences within the worship space. Primarily, movement is seen to bring people in contact with each another, the presiding minister, and the ritual action. One essential movement pattern is a procession which takes place as part of the worship celebration (EACW, #59). In discussing such movement issues EACW unnecessarily reminds the reader about an obvious need to locate furniture and other objects for ease of movement within the worship space (EACW, #62).

In summary, a full worship experience occurs in worship spaces that can allow the whole assembly to gather in active participation. A design which considers the importance of visibility, audibility, and proximity to the worship ritual as well as each person who assembles in worship helps to achieve this active participation. The common assembly, coming together in worship depends upon this active involvement through sight, sound, and togetherness.

A personal and communal experience is desired which recognizes the dual qualities of worshipping both as an individual and with other people. Experiential contributions from the senses fully support this framework of personal-communal worship. These experiences happen within the common yet varied rhythm, pace, songs, and silences of the worship celebration which have historically developed a unique Catholic Church atmosphere. Additionally, a commonality of movement, gesture, and posture exist, developing a taken-for-granted manner of existence enhancing people's attachment towards the worship place.

Thus, according to EACW, encounter identifies the following key characteristics:

- * A full worship experience occurs through the active participation of people in the worship celebration.
- * This active participation is stimulated through having both personal and communal worship experiences.
- * Sensory contributions play a fundamental part in the personal-communal worship experience.

- * Common patterns of movement, gesture, and posture helps to strengthen a person's connection to the worship lifeworld.

Mystery

The third theme, mystery, I define as a person's dependence upon faith, signs, symbols, sacred and spiritual beliefs to feel the presence of God. In EACW, mystery is described as the tension between God and our "human modes" of expression (EACW, #1). It states that while God can not be contained in words or images, or be categorized, it is possible using words and other art forms, to touch without totally grasping (EACW, #2). Such avenues to God exist through the faith communities' weekly worship celebrations as well as individual devotional postures. These ways of touching, though, starts first with the images, signs, and symbols that people see as giving a sense of spirituality and sacredness.

For EACW, mystery is primarily focused on the regular gathering "to praise and thank God, to remember and make present God's great deeds, to offer common prayer (EACW, #9). This gathering in prayer is called the liturgy. The need for liturgy as a common prayer establishes the initial need for a physical structure. It follows that, for this liturgical space certain furniture and furnishings are required to support the modes of expression used in worship.

It is these liturgical elements which help to establish a particular Catholic liturgical typology of a church building. Such a liturgical typology has created special symbols that are seen to support the worship liturgy. For the Catholic Church common symbols of altar, lectern, baptistery, tabernacle, and cross receive special attention in EACW (EACW, #71, 74, 76, 80 & 88).

EACW identifies two problems which tend to exist in the use of these common symbols. One problem raised is a concern that duplication of a symbol will be carried to the extent that one's "human attention and consciousness" of that symbol is reduced (EACW, #86). An example is given concerning how a cross multiplied and repeatedly placed onto many different objects in the liturgical space, "may lessen rather than increase attention to that symbol (EACW, #86). The other problem is that "weak primary symbols" exist at the expense of strong secondary symbols (EACW, #87). An example is that design attention must not focus on developing a common element which is secondary, such as the design of an altar, while ignoring the primary symbols associated with the altar which are the bread and wine (EACW, #87).

An important issue for post-Vatican II worship spaces is how worship liturgy has a deep rooted tradition in the temple archetype classified as domus dei--House for God. EACW addresses this problem by stating that "the historical

problem of the church as a place attaining dominance over the faith community need not be repeated as long as Christians respect the primacy of the living assembly" (EACW, #41, italics added). This important statement sets clear that previous large temple type spaces in the domus dei tradition are not appropriate for present worship structures.

EACW does say that it is this historical tradition which furnishes a "symbolic language" for the action of the worship liturgy" (EACW, #10). This recognizes that those images which create this symbolic language are deeply set in past worship experiences of the liturgy. Further, there is an automatic retention of the wonder and awe associated through these symbols and signs which provides one avenue for connection to God (EACW, #10).

Experientially, the action of worship is found in this "God-consciousness and God-centeredness" (EACW, #12). God-consciousness is stated to involve a beneficial tension between the demands of a hospitable environment and the demands of contemplating God's presence, with contemplation described as "a sense of the holy, the numinous, mystery" (EACW, #12). A sense of spirituality and sacredness contributes to this contemplative manner.

EACW states that the community coming together in worship establishes a powerful experience of sacredness. This action of worship celebration with the whole community is said to be the normative way of celebrating since it

reflects a celebration of life. Further, EACW states that among the many symbols of the church none is more important than the symbol of the community coming together in worship.

Very little attention in EACW is given to the issue of how mystery is experienced in the worship lifeworld. The document either assumes that such knowledge is already well understood, or that the sense of mystery is an inherent part of any worship space. In either case issues concerning attitudes of sacredness and spirituality are missing from EACW but represent key elements which I pursued at Light of the World.

In summary, the essential associations of worship comes from a tension between man and the mystery of God. For the Catholic Church a worship experience provides one method for relating to God or of responding to the way God relates to us (EACW, #13). The place for gathering is no longer thought of as a dominant overpowering space but as a place which is hospitable to those who assemble. Physically the faith community gathers to provide support for a sense of holiness, reverence and mystery. It is this gathering of the community which is said to be the most powerful experience of the sacred.

Mystery, in dealing with God-consciousness produces a sense of sacredness and spirituality which comes from a liturgical climate that expresses "awe, mystery, wonder, reverence, thanksgiving and praise (EACW, #34). Such a

climate is deeply rooted in common symbols of the liturgical celebration. These common symbols have over time generated a symbolic language which gains supports through a person's reverence and devotion.

Thus, according to EACW, mystery, identifies the following key characteristics:

- * As a human mode of expression, the act of worship provides an avenue of approaching God.
- * Tradition and symbols have a deeply rooted history which has produced a current symbolic language that must not be completely lost.
- * As a symbol, the assembly gathering in worship establishes the most powerful experience of sacredness.
- * A sense of sacredness which evolves through a person's feelings of spirituality, reverence, and devotion.

Integration

Theoretically, the worship lifeworld is comprised of a mixture of each theme. Each theme, while representing a single element, develops a unique or special worship lifeworld when placed in combination with the other two themes. Figure 7 illustrates this theoretical relationship in which, ideally, each theme would have equal importance. This means that a sense of the holy is as important for worship lifeworld as are the place for worship and elements of human interactions. It is this concept that has become a central focus for this thesis.

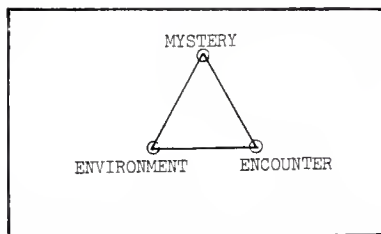

Figure 7: Theoretical Relationships of EACW Themes

The theme environment is principally concerned with the place of worship, and includes concerns of spatial organization, architecture, and all art forms used in that environment. The theme encounter represents how human interactions of senses, movements, gestures, and postures are critical for a personal-communal worship experience. The theme mystery is an attitude of God-consciousness arrived at through faith, signs, symbols, sacredness, spirituality, and reverence.

This interpretation of EACW provides an insight into the ideal qualities believed important for a post-Vatican II worship space. EACW was incorporated into the planning and design of its worship structure at Light of the World, and this church provides the comparative basis on which to judge this ideal framework. The next chapter focuses on the research approaches used to explore these issues at Light of the World.

* * * Studying the Worship Lifeworld * * *

As discussed in chapter two, architecture involves not only the building's physical substance but also factors of human experience (Harries, 1983). Chapter three identified the primary physical and experiential characteristics of the post-Vatican II church that I used to assess one particular Catholic Church. The combined study of the physical environment and how people live within that environment is the study of person-built environment relationships (Seamon & Nordin, 1980). Architecture can be studied in this context by exploring and describing the person-built environment relationship through qualitative research. Using the phenomenological perspective, a multifaceted approach was formulated to achieve a clear understanding of a particular lifeworld.

Critical to this research was how to explore this person-environment lifeworld relationship as it existed at Light of the World Catholic Church. As a researcher, I was interested in both the architectural qualities of this building, such as materials, geometry and color, and in people's experiences within this worship environment. In particular, I wanted to describe the physical setting as well as the parishioners feelings. Thereby establishing the fundamental identification between the place and the people

(Norberg-Schulz, 1985).

The phenomenon studied was the lifeworld of worship at Light of the World Catholic Church. My research focused on comparing this particular worship lifeworld with the ideal worship lifeworld as represented in EACW.

Two key research directions were formulated to look at these relationships. The first direction was to interpret the physical qualities of the worship lifeworld. The second direction was to interpret the worship experiences which took place in the physical setting. Each of these avenues of inquiry was fashioned to explain and describe the success or failure of this particular worship lifeworld in terms of the three major themes of--environment, encounter, and mystery interpreted from EACW.

A key to the success of this research approach was finding a way of seeing the worship lifeworld phenomenon from several different points of view. I was concerned with retaining both reliability and trustworthiness in the research. This concern resulted in the use of a variety of research techniques to explore qualities of the physical space and the way in which people experience this worship space. An important additional element in this approach was how my personal experiences contributed to the phenomenological research.

To describe the physical qualities of a worship lifeworld is to understand the physical state of the

building, those spatial qualities which are visible and generally cannot be changed. To describe the experiential qualities of a worship lifeworld is to understand the sense of place which people have in a particular environment, even though these experiential qualities are in many ways transparent and always changing. Both of these avenues of research create a different impression of the worship lifeworld. Together they provide a focused look at the physical and experiential qualities to be found at the lifeworld.

The research, therefore, involved a multifaceted approach grounded in five primary research methods. The physical analysis was performed through an architectural review and architectural recording process. The experiential analysis was performed through behavioral recording, parishioner interviews and the personal experience of the researcher. These five different methods followed qualitative and phenomenological approaches to conducting research (Lowe, 1987).

Architectural Review

To look at the physical aspects of the built environment is to describe its different characteristics and the formal, spatial, and decorative qualities they project experientially. In phenomenological research, this approach

has been referred to as providing descriptive analysis of the building (Norberg-Schulz, 1985). Such a descriptive analysis of formal and spatial characteristics was undertaken at Light of the Word. Norberg-Schulz (1985, p.13) describes the architectural means by which people reside in their world as falling into different "modes of dwelling".

Three basic architectural divisions of built form, organized space, and building type can help guide a formal interpretation of the built environment. First, the concern for built form is morphology, meaning how the placement of materials produce a building (Norberg-Schulz, 1985, p.26). Second, the concern for organized space is topology, which looks at the structure of the space, such as its edge, path and center (ibid, p.27). Third, the concern for the building's type is typology. which is the building's use, repetitive nature, or general qualities of the building (ibid, p.29). Norberg-Schulz (ibid, p.26) calls these interdependent components leading to an overall "language of architecture".

In addition to this analysis of the building through an architectural language of morphology, topology, and typology, an understanding of an architectural environment may also be formed through what Seibold (1985) calls an "analysis of meaning through associations". He specifically identifies four categories--architectural, naturalistic, anthropomorphic, and literary associations--which can lead

one to a philosophical understanding of a building.

Architectural associations look at how architects, as professionals, review buildings. One typical approach has been a review of a building's geometry. Other approaches focus upon describing individual building elements, such as doors and windows. Naturalistic associations look at a building's relationship to the region's typography, or a comparison is made to natural or animal forms. The concept of anthropomorphic associations is when a building, or any part of a building is compared to a body form. Literary associations look at meanings given to buildings through literature or history.

The architectural program was evaluated in terms of its relationship to EACW, using Norberg-Schulz and Seibold categories. This evaluation was important to compare the built structure to the ideally designed structure, especially since the architectural program extensively made reference to EACW in describing the type of spaces desired. An overall design philosophy given in the program centered on how people of the parish were to be the primary factor in the buildings design.

Interviews with the architects took place on two occasions. The first interview occurred several weeks before the start of the research study to establish preliminary contact. The second interview occurred during the research process, at which time the architectural program

and design issues were discussed. Questions focused on the makeup of the design team, building design and general program requirements.

Architectural Recording

Photographic interpretation in phenomenological research has had many different functions. Photography has supported an author's theoretical discussion (Relph, 1976; Dovey, 1985b; Norberg-Schulz, 1980, 1985); it has been used to establish the overall scale of an environmental setting (Violich, 1985); and to record the qualities of the environmental setting (Whyte, 1980; Seamon & Nordin, 1980). My particular approach combined methods from all these approaches.

The use of photography provided a reliable method with which to record materials and building design. As part of the total research process, photography allowed the people's movements and gestures to be captured quickly for later reference. This is similar to Whyte (1980) in his recording of small urban spaces where he recorded people's different movement and locational patterns for later interpretation.

Sketching was also used to record the architectural qualities of the building. While photography can provide what is believed to be a true and accurate record of the building, sketching forces one to stop and look at the

building more carefully. Violich (1985), in his urban reading of Yugoslavian coastal towns, says that sketching proved valuable for stimulating his response towards the environmental setting. The act of sketching also opened me to new images of the building. It was the relaxing meditative nature of sketching which allowed contact with the more subtle aspects of Light of the World not normally seen. As with Violich (1985), sketching helped me to recognize and understand how the building makes connection to its regional setting.

Sketching and photography complemented each other-- photography, for its quick recording of the building; and sketching, for allowing me to see special details of the building. The drawings presented in this thesis are either copies of my direct sketching or were produced from a projected photographic slide image.

Behavioral Recording

Behavioral recording techniques have been typically carried out by counting interactions, situations, or occurrences. These incidents are, then, marked on a predrawn map of the space showing the location of the incident (Bechtal & Zeisel, 1987). Generally these maps are developed with a precoded recording format in which the observer marks down the number of times an expected occur-

rence or situation takes place. What can be lacking in this approach is the recording of unexpected behavior that was not previously indexed on the map. In always looking for the expected while not recording the unexpected, biased or misleading research can occur.

Because of this concern, behavioral mapping was not used in this thesis as a means to quantify an expected incident, but as a method to provide general information about the experiential aspects of the worship environment. More importantly, I wanted to use behavioral recording techniques as a way to detach myself, periodically, from the actual experience of worship. Rowles (1978, p.185), states that a real danger in experiential field work is allowing oneself to become so involved in the experience that you, as a researcher, become "counter-intuitive". To combat this potential problem, I purposefully set out on several occasions to act only as an observer of the worship space.

Of course, becoming immersed in the experience of the phenomenon is not entirely inappropriate, as long as you can retain the necessary phenomenological research posture of openness to the experiences that are taking place. As an example, Jacobs (1961) in writing about the everyday experiences at her street and neighborhood, established an important understanding about urban neighborhoods not generally seen by the casual unimmersed visitor or researcher. This need for immersion with awareness of the exper-

iential qualities was the goal of the behavior recording techniques employed.

Observational recording primarily centered upon recording parishioner movements before, during, and after the worship celebrations, as well as recording the seating patterns of the worship space. This recording also provided a very general understanding of parishioner arrival and departure movement patterns, that proved to be a cross-check with the information received through parishioner interviews.

While performing this part of the research, I almost always felt detached from the space itself. I felt more like an outsider than a member of the church community. This feeling of detachment became increasingly more apparent when I was carrying a clipboard, or other recording tools such as cameras or notebooks. My contact with the worship space was also diminished because of the need to locate myself in a corner where the entire worship space could be seen. This placement, therefore, removed me from the liturgical action of the service. Thus, at those times I was not really able to participate in the worship service.

To supplement the behavioral recording method, I kept a field notebook in which I could record any incident within a short time after its occurrence. Using shorthand statements, I could record an observation directly after a service, and later, with reflection, record an expanded

version in my journal. This notebook was small enough to unobtrusively fit into my pants pocket, allowing me to always carry it without feeling like a researcher.

Parishioner Interviews

Rowles (1978, p.184) says that one important element of experiential field-work interviewing is to develop an "interpersonal" relationship through conversation. He describes this as a need to have a relationship based upon openness, in which the researcher does not guide the interview process but lets significant discussion unfold in its own way and time. Further, he says such relationships are much better if they develop naturally instead of being forced.

I set out, therefore, to explore parishioners' worship lifeworld experiences through an open-ended interview process. The intention was for the parishioner to allow the interview to move into any area they felt like discussing. While this was my theoretical position, in practice I found it quite difficult to resist guiding the parishioner interview. Whenever the parishioner started deviating, I was not able to completely resist directing the parishioner back to the issue I felt important. Upon transcribing these interviews, I heard myself being too structured in using my prewritten questions, as well as not really interpret-

ing--listening to--the parishioner's response. Because I started transcribing the first interviews before conducting the final set of interviews, I was able to review critically my interview style and minimize this problem towards the end of the research period.

Interviews were divided into three sections. First, questions concerning previous worship experiences were asked. Parishioners were requested to describe churches they remembered best, liked the most, and liked the least. In asking them to remember these church's and describe their worship space, issues concerning ornamentation, decoration, type of seating and other design issues were brought forward by the parishioner. People were very eager to start talking about Light of the World, which initiated comparisons between their previous experiences and present experiences.

Second, parishioners were asked to describe those elements at Light of the World which give them a feeling of spirituality or sacredness. In the process of describing the special qualities of their church, they identified the symbolical religious elements which were important to them. Additionally, issues concerning, sound, solitude, and visibility were exposed as contributing to specialness, spirituality, and sacredness.

Third, parishioners were asked to describe their own movements and actions in the worship space. They were asked to begin at their homes in describing their arrival at the

church, which caused them to be more open and expressive about their arrival-movement process. Descriptions concerning movements inside the church gave clues as to their feelings of closeness, togetherness, gathering, and seating choices, as well as movement.

Interviews were intentionally limited to a small group of people, and this procedure allowed me to spend more time with each parishioner and explore their experiences in depth. During my two month residence in the church community, twelve parishioners participated in these open-ended interviews. With the permission of the parishioners, all interviews were recorded on tape. This allowed my attention to be focused on the questions, answers, and interview process. The average uninterrupted time with each parishioner was 1 1/2 hours, with most interviews happening in a single session. Two separate taped interviews took place with one parishioner. After the initial interviews, further discussion with each parishioner occurred at various parish activities, through informal conversation. In addition, many short-term conversations occurred with other members of the parish at these church activities and parties. Information from these conversations were recorded in my field notebook and journal. I was also invited to participate in a neighborhood community group that met weekly, which provided insights into worship issues.

Parishioners were selected either while attending a

church service or other church community activity. No formal method of selection was followed. This approach has benefits because it avoids receiving a preselected interview list from the parish council or pastor. The weakness, though, is that it tends to enlist more outgoing extroverted people, which can be seen to limit my access to one segment of the parish. However, the segment interviewed still represents a varied worship experience.

On two occasions I asked the person who sat next to me at a church service to participate in the research. Participation by five parishioners came through informal conversation at parish activities, such as a picnic, a dinner or a dance. I met two of the people while visiting the church during one of my first weekday evenings in the area. The remainder of the participants I met during the informal parishioner gathering which takes place in the church foyer after services.

Only three of the interviews took place at the church. The remainder taking place at the parishioner's homes. Four male and eight female parishioners were interviewed. Parishioner's ages ranged from 16 to the mid 50's with distribution as follows: two younger than 20, one 21 - 30, four 31 - 40, three 41 - 50 and two 51 - 60. Although no formal interviews occurred with anyone over 60, several conversations took place with this older age group during my stay at the parish.

Interviews also occurred with the Pastor and the newly appointed Associate Pastor. They also explored the qualities of Light of the World's worship space as well as providing me with a perspective on how they thought the worship space functions. Importantly they gave me guidance to theological views concerning liturgical renewal and Vatican II. Upon completion of an interview, a written transcript was made. From this record, portions of the interviews which provide a description, event or critical comment concerning present or previous worship experiences were copied onto note cards. The cards were sorted into categories complying with the three EACW themes. The responses used in this process can be found in Appendix A.

Personal Experiences

The phenomenological research described here occurred over a two-month period in the summer of 1987. I attended both weekly and daily worship services, numerous parish activities, and social functions. During my stay at the parish I rented living space from a member of the parish, allowing me to participate as fully as possible in all parish activities. Living within the parish and attending the services and social activities, I was able to meet many parishioners.

Such complete immersion into a church community means

that I was personally influenced by worship and community experiences which potentially can cause changes to the people and, therefore, the environment itself. Von Eckartsberg (1971, p. 75-76), stated that "both the person researched as well as the research person are changed through the existential research method--they change each other". Rowles (1978, p184) calls this a "mutually creative process" in which the taken-for-grantedness of a person's experience comes from awareness between the researcher and the people being studied. Awareness also is related to the amount and quality of involvement by the researcher through the development of interpersonal relationships and participation in the environmental setting (Rowles, 1978).

To reduce initially any biases derived from parishioner relationships, I delayed starting the parishioner interviews until after I had developed my own understanding of the worship lifeworld. My use of a daily journal became very important to this early part of the research. I focused on describing the physical elements of the worship space as well as recording my personal experiences. This meant describing how I felt, what I saw, heard, tasted, touched, smelled, and how I moved and positioned myself in the worship space. This part of the research process occurred during the first two weeks of my two month stay. While I purposely did not interview any parishioners during this time, I was meeting parishioners and establishing contacts

with the people who would later become participants in the interviews.

Relph's (1976) idea that a person can have different levels of insiderness, or outsiderness, to a place is a good model for describing how I, personally, was affected during my stay at Light of the World. He states that we experience places according to our amounts of understanding, attachments, and positioning within the space. An important set of experiences that occurred to me during the research study was how I moved through the different levels of Relph's (1976) insiderness continuum. Looking backwards, I can define how his levels of vicarious, behavioral, empathetic, and a beginning level of existential insiderness occurred.

Vicarious insiderness happened when I saw Light of the World in Progressive Architecture (Feb. 86), as the images gave me a feeling of warmth and enjoyment, giving me "a deeply felt involvement" with the building (Relph, 1978, p. 52). Relph (1976) states that such a level of insiderness comes from receiving a positive image of the place before one has ever visited that place. While I now classify this initial view at this first level of insiderness, I was also extremely relieved and happy to find a Catholic Church which seemed to contain all the necessary requirements for this research study.

The behavioral insiderness aspect was present at the very beginning upon arriving at the church. I came into the

building and recognized that it had "a set of objects, views, activities arranged in certain ways" which would establish "certain observational qualities" (Ibid, p.53). I did not stay in this state very long. In fact, by the middle part of my first worship service, I sensed that the space had a special importance and significance to these people. As a researcher this was a welcomed recognition, I had established quickly that the worship space topologically followed and expressed what the document EACW said should ideally occur.

My experience of having an empathetic insideness lasted approximately one month. Relph (Ibid, p. 54) said that to be inside a place empathetically is to understand that such a place has a richness in "meaning". I was looking at Light of the World seeing its uniqueness as a place from the meaning given to the space by the people, which further indicated the buildings specialness. As Relph (Ibid, p.54) would explain, I had "a willingness to be open to the significances of the place". It was during this time that I was recording the physical characteristics through photography and sketching which mentally opened up the unique qualities of Light of the World.

I was able to, however momentarily, reach a level of existential insideness during the sixth week of my research. Relph (Ibid, p.55) describes existential insideness as the "insideness most people experience when they are at

home, ... when they know the place and its people and are known and accepted there". What becomes to exist from this experience is a strong connection to the place. An excerpt from my journal, I believe, best recounts my movement into a level of existential insideness.

This Saturday evening when I walked up the sidewalk I felt like I was returning home. For some reason--maybe because I had traveled to Manhattan and back during the middle of the week--I had this feeling. But tonight I had that relaxed sense of when you return to a place where you find friends, where you know there will be a smile waiting for you, that people will come up to hug and say hello, letting you know you are welcomed to this place. This is what I felt, and it seemed that these people being there made my being seem real and with a purpose.

This experience made me feel that I was no longer on the fringe looking into the space, but was inside and a part of the space. This level of experience initially caused me to consider the results of my research, making me think that I could be biased in my research. I questioned if I really remained focused throughout the research. This level of experience, however, helps to validate responses received from interpreting the physical and experiential qualities of this worship environment.

Prospectus

The preceding chapters have set the stage for the presentation of the worship lifeworld found at Light of the World. Chapter one provided general information on Light of

the World and focused on giving a clear picture of its physical characteristics. Chapter two defined key terms, such as worship lifeworld, and reviewed related literature on space and place theory, sacred space and development of the post-Vatican II Catholic Church. Chapter three identified the key physical and experiential attributes of the ideal worship lifeworld as represented in EACW and described them as becoming to three interconnecting themes.

This chapter has described the ways in which this research was conducted and the theoretical basis for my approach. Each of the following three chapters will focus on one of the three major themes of environment, encounter and mystery. Discussion in these chapters is based on my interpretations, observations, interviews and experiences. The factors found at Light of the World are compared to the stated ideal at the end of each chapter and areas of contradiction or agreement are identified.

* * * Worship Structure and Gathering Space * * *

This chapter focuses on the physical and experiential aspects of the environment theme at Light of the World. The first four sections review these qualities and the last section compares these characteristics with the ideal expressed in EACW. The initial two sections--"formal structure" and "worship structure"--explore the physical attributes of the theme. The next two sections--"gathering space" and "quality and appropriateness"--explore the theme's experiential attributes.

Environment most generally represents the physical place where people gather for worship. All churches are gathering places, and formal characteristics exist which help determine the experiential qualities of gathering. Environment establishes a worship typology which consists of the worship space, non-worship spaces, and physical elements such as furniture and art. For the Catholic Church, this typology is ideally a non-dominant, human scale which provides hospitality towards the people who assemble in the environment. The qualities of this environmental setting are also established through the building's connection to its landscape, city and region. Environment, therefore, is holistic in terms of a church's physical existence as a place.

The architectural firm for Light of the World--Hoover Berg Desmond of Denver, Colorado--stated in their interview that the church has received design awards and national attention because of its departure from what had been done previously in Roman Catholic Church design (1.13)₁. The architects believe that Light of the World, materially and philosophically, represents a change from both traditional pre-Vatican II church design and from other current post-Vatican II church designs. This chapter identifies those factors which lead the architects to believe these differences exist.

The divisions of the chapter evolved out of my interviews with parishioners as well as the architects. While the architects focus on Light of the World's uniqueness, parishioners consistently mentioned that the assembly or community is their prime focus. Different aspects of the building were seen to enhance the quality community assembly. Parishioners collectively identified, however, that the gathering of the assembly contributes most to a sense of community. The space was consistently seen as a hospitable environment for gathering primarily because of the use of movable furniture. While movable furniture is not the norm in Catholic worship spaces, the parishioners continually stated how the flexibility and resulting openness of the

¹ Information obtained from interviews is identified by a coded number. Refer to Appendix A.

worship space provided a feeling of hospitality. Further, a pride in ownership of the building existed in all parishioners interviewed.

Thus, this chapter first looks at the formal qualities of the architects' design. The initial concern was the building's general morphological and typological characteristics as a place of worship. These issues are discussed in the sections on the building's formal structure and worship structure. Parishioners' identification of how gathering develops community marks the next section of the chapter. In the last section the focus is on how the quality and appropriateness of the built environment contribute to parishioners' attachment to their building.

Formal Structure

Norberg-Schulz (1980, p.65) states that "the meaning of a building is related to its structure"--that is, the physical form of its construction. He calls this formal quality morphology, which he says can be defined by or result of a building's relation to sky and ground, its openness or enclosure, the materials and methods of construction as well as the manner for receiving light (ibid, p.66).

In this section I examine the morphological qualities of Light of the World. This explication provides one way to

explore the worship lifeworld in terms of its physical properties of construction. One characteristic of Light of the World's formal structure is its openness and enclosure in regard to the exterior. Most church structures have historically been planned to offer only minimal visual openness to the exterior. Generally speaking, exterior openings in the worship environment have been glazed with stained glass which offers visual images for the interior space rather than creating an openness to the exterior. Of course, churches exist which have transparent glazed walls. An extreme example is the Crystal Cathedral in Garden Grove, California. However, this design characteristic is not the norm.

Figure 8 illustrates this openness and enclosure quality that occurs at Light of the World. This plan view is drawn to show only the location of opaque walls and doors, all transparent glazed door and window openings are left clear. Three major characteristics of the building become apparent from this drawing. First, the worship space follows a traditional pattern of minimal openness to the exterior. Second, no openings exist along the street frontage or north side of the building, except for a series of small glass-block clerestory windows in the worship space. Third, the remaining principle areas of the building are relatively open to the exterior without any major vision barriers.

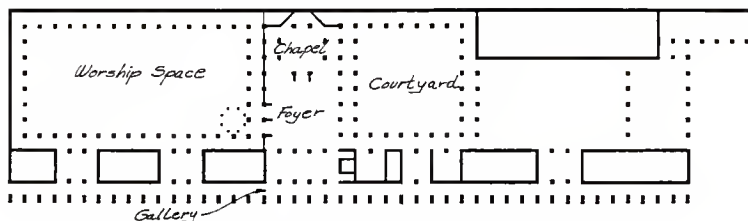

Figure 8: Openness and Enclosure Morphology

This manner of openness and enclosure creates different interior to exterior relationships. Norberg-Schulz (1980) gives two examples concerning how such relationships are formed. He says that placing small openings or "holes" in a massive exterior wall will give "emphasis to enclosure and integrity, whereas the filling of a skeletal wall by larger surfaces of glass...creates an interaction between exterior and interior" spaces (ibid, p. 67).

Such interpretations can apply to *Light of the World*. The worship space, which only has a series of small window openings above eye level, has a the feeling of unity and completeness. In the other parts of the building a sense of open relationship to the exterior is present. Importantly, the design placement of window openings maximizes views of the Rocky Mountains and establishes a high degree of connection to the natural landscape. These qualities of openness and enclosure help to establish a particular identity of a "man-made place" (Norberg-Schulz, 1980,

p. 69). Of course, as Norberg-Schulz (1980) points out, such elements are not the only concerns in building, as issues of material, color, and texture are all linked to a building's morphology.

These formal morphological qualities, which lead to a building's identity, are most apparent in comparing the almost windowless north wall with the more open south wall. For many parishioners, the north wall creates a negative image. Figure 9 shows a view of this wall from street level which expresses a barrier between the church and street. The strong linear quality of this ten foot high wall, its solid windowless form, and the sloping earth berm tend to elevate the building above the observer's position.

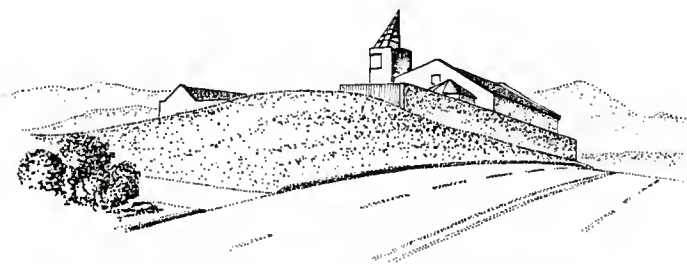

Figure 9: Street View--Building's North Wall

These elements encourage the feeling of detachment, removal, or barrier. As one parishioner said, "I wish when you drove by that you did not see that big blank wall, it

looks like your hiding from somebody" (6.3). Other parishioners simply used labels to define how they felt, saying, that the north wall makes the building look like a prison or a place where concrete blocks are made (12.4 & 2.1). One parishioner stated that his first impression was that Light of the World "was closed off to the world (which) they were suppose to bring light to" (14.2).

The fence-like character of the wall develops an architectural association to the many street frontage fences that surround most suburban residential developments in the area. Similar to the north wall, the fence creates a separation between the major arterial street and the residential satellite neighborhoods. Figure 10 illustrates how these fences create visual as well as physical separation from the street. This view shows Light of the World as one would approach from the west.

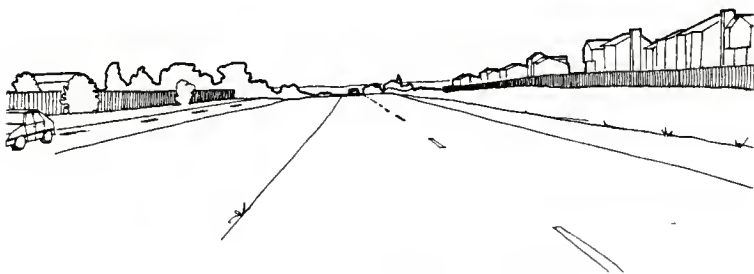

Figure 10: View of Western Approach

Opposite both in design and parishioner image is the south side of the building. Parishioners are so attracted to this side of the building that they forget the north wall exists. As an example, one parishioner dismissed the north wall as representing the church. She recalled how once when showing a friend the church she had to move to the "front" (south side) to "really see the church" (10.5). This out of sight out of mind phenomenon, which ignores the north wall's existence, was observed in several parishioners.

Figure 11 illustrates the south side of the building. The distinctive features of matched door and window openings and lack of any raised building platform or steps was critical to creating a sense of interaction between the exterior and interior. These two design features enhance the transparency between inside and outside.

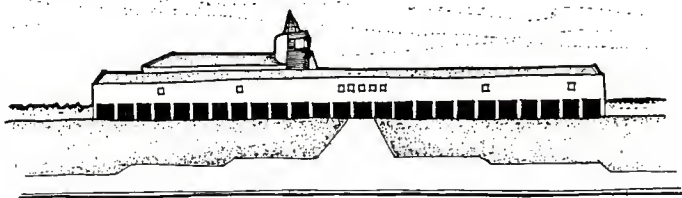

Figure 11: South Elevation

The design opposite created between the north and south side of the building was not an arbitrary design solution. The liturgical artist described that "throughout the building one finds opposites of brick and glass, light and dark, indoors and outdoors, horizontal and vertical, circle and square ..." (Buscemi, 1987, p.1). A formal concept of reconciled opposites was an integral design philosophy used in the design of Light of the World. The only non-opposite design element appears to be the overall linear pattern of the building, yard, and parking.

Figure 3, the architects' site plan in chapter one page 7 shows these three principle elements of building, lawn, and parking in this linear organization. The building form is adjacent to the street frontage and occupies the highest topographical elevation of the site. A naturalistic association can be seen to exist with this linear plan through a relationship to the general linear topographical features of streams, lakes, and valleys in this area of the city. While such an idea is intriguing, the architects never described such relationships existed in their design.

This comprehensive linear pattern was described by the architects as responding to the required spatial organization for the church. The architects said they "were concerned about what you typically see in every church, a lack of organization, a lack of a master plan" (1.7). The coordinating element identified as central to this master

plan was the linear gallery which runs east-west along the south side of the building. From this spine the major spaces become accessible and linked together.

Along with this formal linear organization, the architects established a rigid spatial geometry based upon an eight foot grid organized on the cardinal points (1.30). Figure 12 the architects floor plan, showing the completed first phase and future second and third phases of construction, indicates how rigidly the architects were tied to this grid. Every building column and room volume has been established by the grid. Visually the modular dimensionality of this grid is most apparent from the exterior when viewing the gallery space.

The formal characteristics of this eight foot square modular floor grid is but one manifestation of a highly articulated geometry. The building is totally based on square geometry occurring in various combinations from small to large. Figure 13 illustrates how the building's present and planned topology consists of squares or a combination of squares. The larger interwoven double square in the drawings upper left indicates the future worship space. The middle section of the drawing is a layered combination of smaller to larger squares and identifies the entry sequence exists through a changing combination of contracting and expanding spaces. The three squares to the right represent the courtyard and future fellowship multi-purpose space.

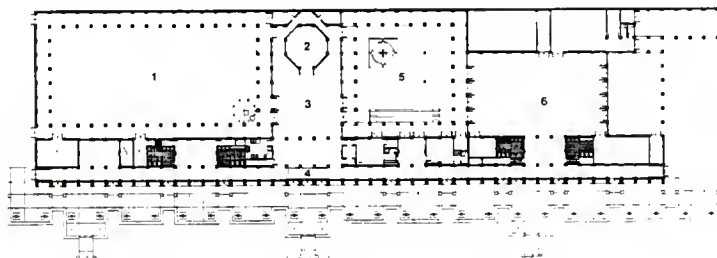

- 1 Worship Space
- 2 Chapel
- 3 Foyer
- 4 Gallery
- 5 Courtyard
- 6 Social Hall

Figure 12: Architects' Floor Plan (Phase 1, 2 and 3)

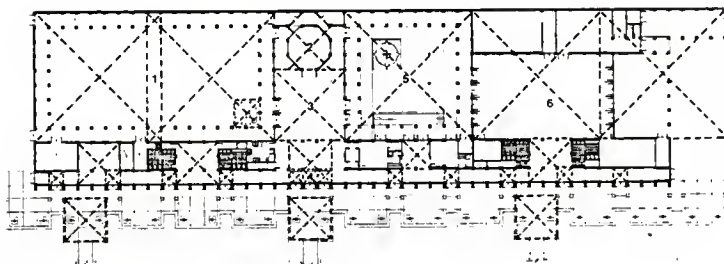

- 1 Worship Space
- 2 Chapel
- 3 Foyer
- 4 Gallery
- 5 Courtyard
- 6 Social Hall

Figure 13: Square Topology of Floor Plan

This square geometry exists not only in this horizontal dimension but also in the vertical dimension. Figure 14, a cross-section through the building, shows how the structure at the gallery and worship space is geometrically established by the square patterned topology. As is true for the floor plan, certain elements have width to height ratios other than 1:1. As illustrated in the cross-section, the tower and gallery have, respectively, width to height ratios of 1:3 and 1:2. This cross-section also shows how the main worship space has a width to height ratio of 2:1 which is proportional to the worship space's floor plan.

This vertical geometry is continued at the exterior elevations, door, and window openings. Figure 15, a partial elevation of the building's main entrance, shows how the elevational facade is based on a double height eight foot grid. Strategically, within this grid occurs the 7'x7' double doors or windows, 3'x3' glass-block windows, twelve inch square glass-block windows, and four-inch square brick pattern. This rigid geometric pattern used on the exterior does not, however, appear forced or cosmetically applied. The overall topology is comprised of square patterns layered within other squares patterns. Clearly such an ordered building leaves little room for variation.

This lack of spatial variation did not affect the larger more important spaces, but the small ancillary spaces of the building were not so fortunate. Parishioners

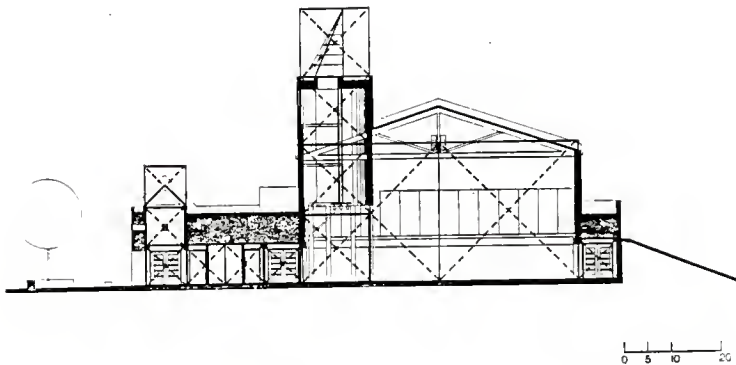

Figure 14: Square Topology of Building Cross-Section

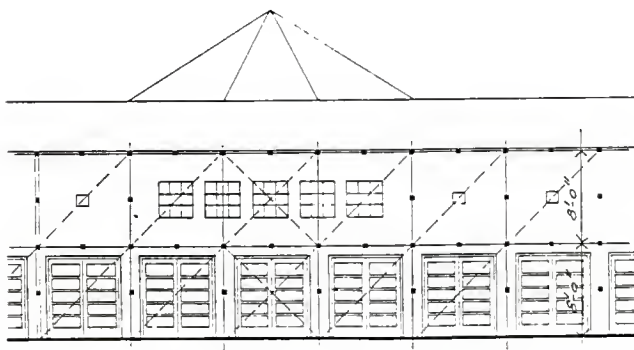

Figure 15: Square Geometric Pattern--South Entrance

questioned why the architects provided such a small space, or why was this space located so inconveniently. In particular, spaces that received the most parishioner attention appeared to be those spaces which were the left over spots of the plan.

The space that received the most negative comments in the interviews was the cryroom space. This area is suppose to provide parents with small children an opportunity to attend church in a space separate from the worship space yet connected visually and audibly with a speaker system. The space designated as the cry room, however, lack any effective means to restrict children movement, lacked visibility into the worship space, and contained a speaker system worse than found at a drive-up fast food restaurant (8.17) (14.8) (15.13) & (15.20).

Other spaces receiving negative responses included: the reconciliation room, for its closet-like location and hospital like esthetics; the rooms for religion education were described as smaller than small spaces for the number of people using those rooms; and the general lack of storage facilities meant that chairs and tables are stored behind the chapel and are visible from the foyer space (2.11) (2.12) (14.6) & (15.12).

In an overall critical evaluation, I would propose that the architects were successful in developing a rich contemporary spatial topology for the principle building spaces.

The rigid adherence to their organizational grid, however, appears to have forced many rooms into spaces ill fitted to handle the desired objectives. The building's highly developed formal structure suggests that these spaces were simply forgotten in the overall design topology of the building.

Worship Structure

Hillard (1980, p.6) stated that "Christian worship is the open display of the Church as the community gathered together by the Lord". He was describing this gathering of the community as representing the new concept for post-Vatican II Catholic worship space design. It is further recognized that such a gathering of the faith community requires a structure. This structure is, however, not just a building large enough to accommodate a large group of people. Rather, it is a structure designated for Christian worship, and because of that fact it has developed a particular set of images that create a worship typology.

The pre-Vatican II typology of a Catholic worship structure contained three principle physical elements of a large nave space, separate sanctuary space, and a vertical bell tower. This typology most readily fits Turner's (1979) temple archetype of domus dei--House for God--as described in chapter two. EACW in describing the post-Vatican II

worship structure states that the building used for worship should be a space for a general gathering space for the assembly. This typology most readily fits Turner's (1979) meeting house archetype of domus ecclesiae--House for the People of God--as also described in chapter two.

There remains with many Christians including Catholics, however, a traditional image as to what constitutes a worship structure. I would argue that people still identify a Christian Church by two exterior physical elements. First, the horizontal nave space has a volume large enough to assemble the expected congregation. As an example, one parishioner remarked during his interview that one way he knew that Light of the World was a church was because of the large size indicated a place to assemble (13.2). Second, a vertical element, most generally a tower, which rises above the rest of the building and will typically have a cross at its top. For example, one parishioner commented that she "consciously always looks at the tower when she comes to worship" (4.17).

White (1980, p.61) recognized that this physical image of church has existed through most of the Catholic Church's history and represents two distinct implied connections of "God to human by the vertical" and "human to human suggested by the horizontal". It is not appropriate in this research to speculate how these two elements have evolved differently over time. What is important, at this time, these two

physical elements most concretely represent the exterior image of the Christian Church.

In considering each of these two physical elements, it is the vertical quality of a tower which still controls the exterior image. Such is also the case at Light of the World where the one element that most distinguishes the building as a church is the tower. The building would easily look like a small shopping center or gymnasium if it was not for the tower. The tower is that typological element indicative of church. Its presence establishes that vertical dimension or axis mundi, which Eliade (1961) describes as representing a transcendence point between heaven and earth. The one-quarter conical stainless steel skylight monitor that marks the tower's terminus is what draws attention to this tower, not its height or absence of an ornamental cross at its top. As one parishioner stated, "I love the skylight its symbol is like a stairway going to heaven" (7.10).

The skylight's reflective materials provide an external contemporary quality that contributes greatly to the building's prominence. Interestingly, the absence of the cross from the tower was never mentioned to be an important issue for any parishioners interviewed. Figure 16 illustrates how the tower's vertical form pierces the horizon helping to establish the building as a reference point in the region. Norberg-Schulz (1980, p.19) defines the psychological function of providing "orientation" for a

place occurs when a physical element is visibly placed in relation to the overall landscape. Physically the tower marks the building as a worship structure while at the same time denotes the building as a landmark.

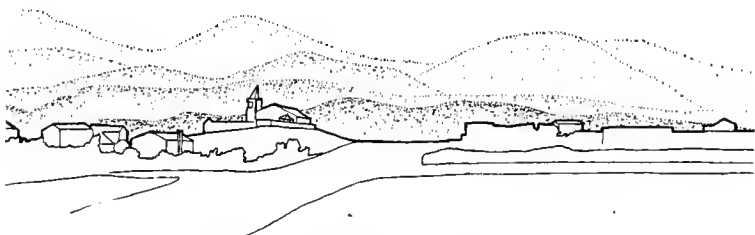

Figure 16: View from East

An important quality that allows the tower to function in this way is the building's position in the landscape. The building is visible from every direction except the northeast because of its site placement. Figure 17 shows a typical view, a sketch made about one mile from the building. As is seen in this view, the building is easily visible above the neighboring house structures. While a large structure, such as a church, could overscale a neighborhood, this structure seemingly compliments the residential neighborhood, displaying an image similar to a Mediterranean village. Because of this landscape position, Light of the World is a visible landmark, or public symbol, commanding attention within this area of the city (Tuan, 1974a).



Figure 17: View from Southeast

While Light of the World can be described as a public symbol because attention is drawn to its presence, the building is always seen to be a worship structure. In particular, non-parishioners may have difficulty reading the contemporary physical images that give a clue its use as a worship structure. As an example, one parishioner noted that when talking about Light of the World to a non-parishioner they will say, "is that really a church" (4.5).

The reason for this may reside with the positioning of the main building entry away from the street facade as well as the barrier quality of the north wall or the short tower height and its lack of a cross. One additional issue is, however, the manner in which the architects have effectively covered up the two primary physical elements which most generally constitute a church. If one would remove this cover a very traditional basilica church typological image emerges.

Figure 18a shows only the volumetric form of Light of the World's worship space and tower. The resulting image typifies a basilica church form through the positioning of

doors into the space, the end gable window, the low sloped gabled nave, the small clerestory windows, and the vertical tower as a corner anchor to the building. Figure 18b shows how when Light of the World's complete volumetric form is placed these same typological elements become hidden. The hiding of the traditional basilica image, coupled with the architects highly geometric patterns, have created a contemporary space out of a traditional formal worship structure.

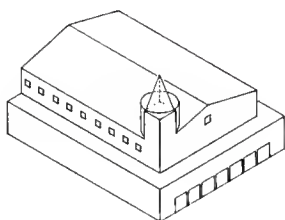

Figure 18a:

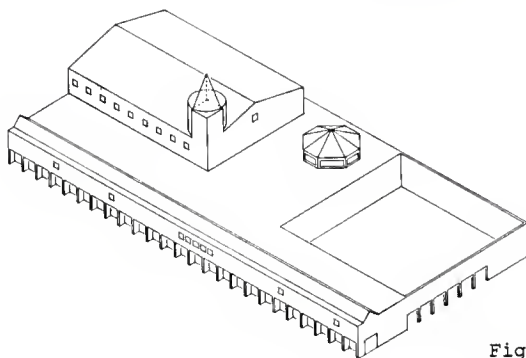

Figure 18b:

Figure 18a and 18b: Volumetric Form Studies

While partially hidden, the worship structure is visibly present in a vertical and horizontal dimension. These qualities do, however, only give moderate orientation to the building as a worship structure. The architects have, however, created a transitional and contemporary worship typology that is a vestige of traditional worship structures. The complementary manner of combining these physical elements has produced a livable image of a Catholic Church for the parishioners.

Gathering Space

EACW states that it is the people celebrating in the action of a assembly which becomes the most sacred experience to be found in the worship space. Further, EACW describes that the most appropriate space for this assembly action is a general gathering space where the whole assembly can take part in the worship celebration. In the architectural program this same philosophy was restated by saying that the primacy of the assembly was the most important issue (Hoover Berg Desmond, 1981).

Additionally, EACW stated that worship celebration of the assembly flourishes in a climate of hospitality. The document identified that hospitality occurs when people are comfortable with each other and the space used for worship.

The physical requirements stated was to have "a space in which people are seated together, with mobility, in view of one another as well as the focal points of the rite" (Bishops Committee on Liturgy, 1978, p.11). How the building responds to these physical requirements is one focus of this section.

This concern with a person's proximity to the liturgical celebration as well as the rest of the congregation has established standards for seating distances. Beard (1988) provides a review of common seating patterns and uses distance from parishioner to the altar as one consideration for evaluating worship environments. He states that when seating is within sixty-five feet of the altar area a person will have good proximity and visibility to the liturgical action. Further, those seats within forty-five feet would be considered the best position, while seating beyond seventy-five are inappropriate because all facial and personal expression of the ministers are lost.

Using this same criteria, Light of the World's present as well as future worship space has no problem in meeting this proximity rule. Figures 19a and 19b illustrates both seating arrangements used at Light of the World. Only the very far outside corner in the semi-circular arrangement does seating fall outside the forty-five foot radius. While this simple criteria for distance may be met in a worship space, a sense of community does not automatically exist.

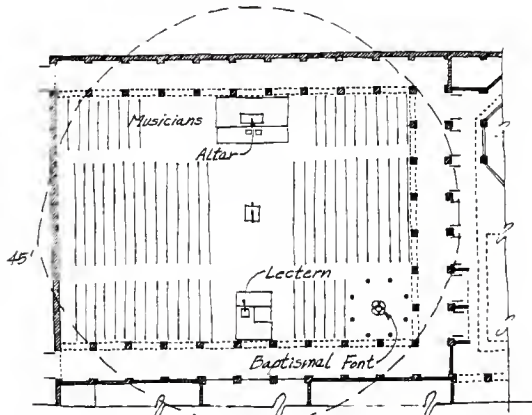

Figure 19a: Face-to-Face Seating

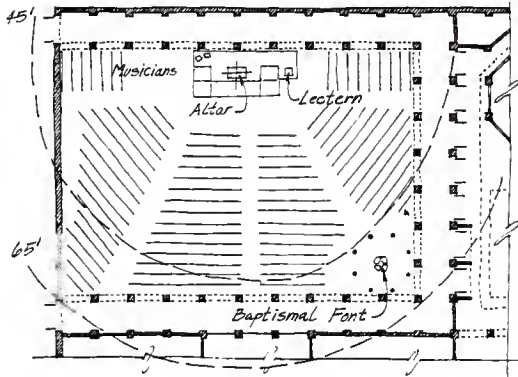

Figure 19b: Semi-Circular Seating

Figure 19a and 19b: Worship Service Arrangements

The important physical quality that promotes gathering, identified by parishioners as Light of the World's greatest asset, is the movable furniture in the worship space. The worship space was conceived by the architects as one large room with no fixed furniture except the baptismal font area. This open type of space was described by one parishioner as representing a Puritan meeting hall (8.21). Such a description can be seen to relate directly to Turner's (1979) meeting house archetype.

The reason to design such a simple space with movable furniture was described by the architects as responding to EACW's call for a "return to a more basic, fundamental christianity, ... something that was flexible and something simple" (Culver, 1987). The majority of the parishioners interviewed expressed their liking for their worship space, even if they did not see the formal basilica typology that the architects had referenced in their statement.

One parishioner described how he felt welcomed in the space as the space gave him a sense of "freedom to move around ...you feel like you are at home" (14.3). Another parishioner said he likes the open space, because it all is usable, and he never gets a bad seat (5.6). Still another parishioner expressed that because of the simple design even greater opportunities in its use exist. She said "I don't think we have fully utilized that space yet, every year we do more and more things, it is only as limited as the people

use it" (15.8).

At Light of the World the seating and altar area is rearranged to coincide with the four distinct liturgical seasons which occur during the year. Two principle seating patterns, face-to-face and semi-circular, are used for these four seasons. The face-to-face pattern is used for Advent and Lent-Easter liturgical seasons. The semi-circular pattern is used during the remaining periods of time. This seating pattern provides the common or standard arrangement which is used approximately thirty-four weeks of the year.

It was the least used face-to-face arrangement that parishioners say provides a special sense of gathering (4.6) (8.30) (10.8) (13.24) & (14.20). Figure 20 illustrates this face-to-face seating, this sketch shows the presiding minister at the lectern delivering a homily. One parishioner stated she felt that sitting and facing each other is a terrific preparation for the Lenten experience, as it "lets us confront who we are" (4.6). She was describing how the face-to-face seating puts people on stage, but because of that action a commitment to gathering is expressed to everyone else in worship space (4.41). Another parishioner experienced a relaxing quality from this arrangement and stated that "you look across and people smile at you and that is real neat" (10.8). Experientially, a higher sense of gathering is expressed by the parishioners through this ability to rearrange the worship space.

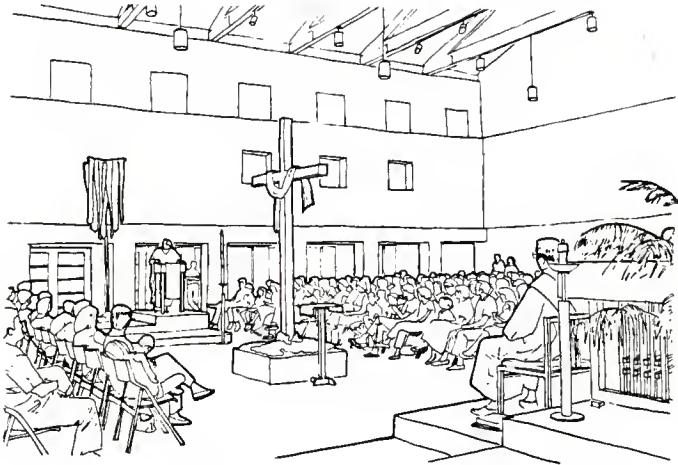

Figure 20: Face-to-Face Seating in Worship Space

The architects believed that this flexibility was a key factor for a person's full worship experience. Saying their design shows "what the proper architectural response is for worship" (1.16). This quality of altar, lectern, and presider's chair all movable within the worship space is the prime foundation used to produce a sense of gathering as an assembly. The flexibility expands to the seating and comprises one of the most important single element as to how the action of the liturgical celebration is experienced. The use of movable chairs and altar furniture, in place of fixed pews and sanctuary furniture, is not the normal design solution when compared to other recently completed Catholic Churches.

Parishioners see many advantages of chairs over pews, not the least is the feeling that chairs are not the traditional and ordinary solution for a worship environment. While the use of chairs distinguishes the parish as progressive, the creation of a space that allows comfortable gathering of the whole assembly was the prime issue. This sense of comfort was expressed by several parishioners. One parishioner said of the chair seating, "it gives me that feeling it is more like a house setting with a bunch of guests" (5.30). Other parishioners recognized that chair seating caused people to be more relaxed and at home (4.12) (5.42) (14.27) & (15.9).

Of course, as one parishioner stated "Catholics, who all have used pews, know that, in general, pews are less comfortable" (5.7). This parishioner indicated that the posture of kneeling never really allowed him to feel at home. Another parishioner summed up the contemporary view most parishioners' felt by questioning why would you need pews unless one wanted to be traditional (13.11). Every parishioner interviewed, in fact, favored the chairs over pews not only because of comfort but also because chairs offer the ability to rearrange the space for different liturgical seasons. As the associate pastor identified the flexible space was an opportunity and stated, "the openness is important because it is there for the potential use" in the development of liturgical services (3.4).

Several parishioners had mixed opinions concerning the use of the worship space for other than worship. A typical response was given by one parishioner. She felt uneasy when on Saturday night you might attend a dance in the worship space and then the next morning attend Mass in the same space (7.2). She remarked how convenient it is to have such a multi-purpose room, but when the altar furniture is visible at the dance a diminishment of its symbolism occurs. In an opposite responses, though, a parishioner stated how he liked having such a multi-purpose space because it represented sound fiscal responsibility by the parish in using something several different ways. For him the "utility" of the space was important (8.1).

Many parishioners responded, however, by saying that having a space for dances, meetings, and dinners does not reduce the space's function as a good worship space. Most agree it would be ideal to only use the space just for worship, but they are tolerant that it now must function for other parish activities. Experientially, this is a significant philosophical message which says that the development of community based on all types of gathering activities is more a primary goal rather than creating an edifice which becomes used only once a week. This does not preclude, however, the psychological importance of wonder and contemplation that can occur in a place designed just for worship, which will be explored in chapter seven.

While the worship space as a multi-purpose space promotes gathering, it is the foyer space which was designed as the principle gathering area. The pastor stated that the foyer was a space that parishioners not only like but they really used (2.8). It is a place for conversation, a place for meetings of senior citizen groups, a place to set up food tables for a dinner celebration, a place to meet other parishioners, or a real gathering place. It is this space where community building experiences between people of the parish takes place.

As my first person interviewed said, "the Foyer is used for everything from dances, dinners, meetings, ... its one of the areas that help develop community" (4.13). Another parishioner said he knew that the Foyer was designed to be that kind of a space to promote gathering, where people can mingle comfortably, "the foyer is a place to gather, it enhances the concept of community" (13.20).

In most Parish buildings built prior to Vatican II the only place to gather conveniently after service was in a vestibule, maybe ten foot wide, or people meet on the front steps of the church. Either way a concept of gathering was not present. At Light of the World, problems with weather or adequate space does not happen. Additionally, with a half-hour period of time between mass services, a respectable amount of greeting and talking can occur without disrupting the next service.

The architects said that they felt it very important to provide such a space, one in which people could gather before and after services stating that the foyer was a very important element of the total design (1.15). One college-age parishioner defined this importance quite clearly when she said, "they built that so people could congregate and talk and share with each other, and then go in (to the worship space) and share with the Mass" (11.5). The foyer acts not only as a place to share with others but also as the beginning point for the start of the worship celebration. The space acts as a preparatory or transitional space that helps to mentally prepare you for the worship service. It does this job as well as provide a functional use space for a variety of activities.

The courtyard becomes another important experiential gathering space at Light of the World. It is an outdoor space that really acts like a backyard of a person's home. Just like a backyard the space can not be easily seen from the main entrance. Its square configuration, recalls the architects formal geometry of the building. Within the grass area of the courtyard is the parish's only fixed permanent cross.

For some parishioners the courtyard serves the same purpose as the foyer space. As one parishioner said, the courtyard "means to me unity, togetherness, getting together with other parishioners, being a part with everybody else,

which means being a part of the church, part of God" (4.13). She also said that the courtyard facilitates this ability to gather as a community as it is easier to share with each other. My observations indicated, however, that the courtyard is one area where gathering experiences that are derived from the foyer and worship space overshadow the actual experiential aspects of this space. Figure 21 illustrates how the courtyard is designed with a recessed central pit and surrounding trellis covered walkway. These two areas are effectively separated through the architects' design solution. In creating a recessed central area they have established two isolated spaces within the courtyard, which has reduced the spaces effectiveness for large gatherings of the parish.

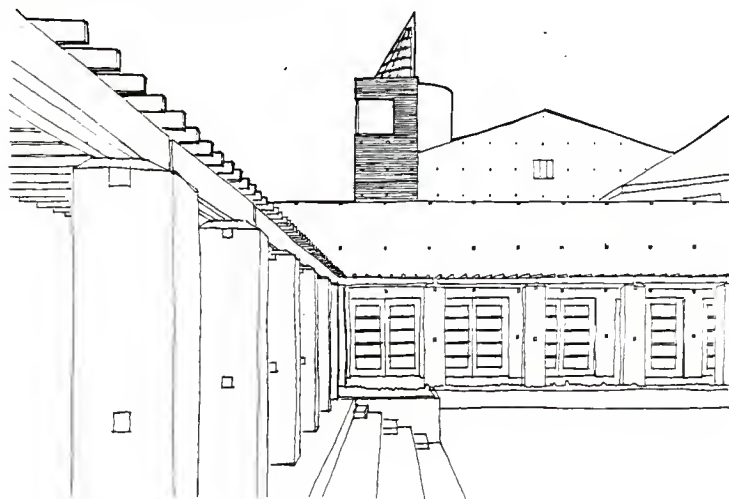

Figure 21: Courtyard

Several parishioners also saw the courtyard as being a nice but limited space to experience. Problems do occur with large gatherings, as one parishioner explained, the courtyard is just too small for a major parish activity (14.4). One parishioner at a dinner in the courtyard, mentioned its limited seasonal use, stating it must be sunny or clear because it offers no protection. Problems also exist in an individual's use of the space. The type of door hardware specified by the architects means that people can get themselves locked in the space. This problem has diminished the use of the space as an individual meditation area, which is desired because of the fixed cross located in the courtyard (4.14).

Importantly, the combination of these three spaces form a spatial topology that enhances the opportunity to gather with other members of the parish. The design of the foyer space is fundamental in causing people to come in contact with other each other. Most important, the space is the hub from which access is gained to the other spaces. Additionally, the off axis design of the entrance to the worship space causes people to slow their pace through the foyer, which creates an opportunity to connect with other people. The worship spaces use of movable furniture creates a higher sense of gathering. The courtyard could have provided a nice complement to the foyer space had the design problems of total accessibility and spatial use been resolved.

Overall, Light of the World's design philosophy of the need for gathering and assembly space is provided. The design of the flexibility in the use of the worship space combined with the other non-worship gathering spaces has meant that the building is used throughout the week. The only physical problem is the inability to handle large gatherings of parishioners. The design of the building was, however, based upon a much slower rate of parish growth than what has occurred. This unexpected increase in the total number of parish families does put a strain on the facility. The ability to handle large group parish activities will, however, continue to be a problem, in part because this parish appears to have a high participation in these type of activities. Once the planned construction phases have been finished, problems that some parishioners have, with the worship space used as a multi-purpose room will cease, since a planned fellowship hall will provide for these activities.

The critical element concerning Light of the World's gathering spaces is how their spatial topology creates an opportunity for gathering. The central location of the foyer with the main entrance to the building, which causes people to arrive through this space, contributes to this situation. Interestingly, the design of Light of the World has created formal as well as informal distinctions of gathering.

First, a formal level of gathering occurs is present in the building. Formal characteristic of gathering is supported primarily through a spaces sense of unity and enclosure. The physical ordering of walls and windows establish a set gathering pattern which creates a formal characteristic. The placement of the columns in the courtyard and construction of a veranda is an example of this formal ordering which has established a set yet isolated gathering place. The use of side aisles in the worship space is another physical characteristic that establishes a set gathering pattern.

Second, an informal level of gathering is also present. At the foyer and courtyard this informal nature of gathering takes place through a lack of physical building enclosure. In the worship space this informal level of gathering is supported through having chairs instead of pews. People can see through these chairs which creates an openness not available with pews. The flexibility of the space gives people a feeling of hospitality,

Quality and Appropriateness

EACW states that for a worship space to be a gathering and hospitable space a sense of wholeness and integrity must be present. The document expresses that integrity in all art forms, such as music, drama, painting, sculpture,

furniture, or architecture, must meet two important demands of quality and appropriateness. Quality is said to come from the honesty and care that goes into making an art form. Further, any art form exhibits this quality when it is well-crafted and displays the genuineness of material, form, color, texture, or style. Appropriateness is concerned with how the art form supports wonder, awe, or contemplation in the liturgy. Additionally, an art form is considered appropriate only when it clearly serves not interrupts the liturgical celebration.

The most significant elements of Light of the World's art and architecture are the heavy dependency upon parishioner created liturgical decoration. In contrast to many Catholic Churches, the amount of permanent art is relatively low. The altar furniture, courtyard cross, tabernacle, and mobile above the baptismal font represented the major extent of liturgical art at the parish. While an issue of cost played a role in the reduced purchase of art works, it was also a planned response. This action created an initial dependence for the people of the parish to develop appropriate liturgical decoration.

An important issue is providing a worship space which would allow the parish an opportunity to create and use their own decorative art. The architects have, in fact, developed a space that almost demands this decorative art. As one parishioner stated, "the worship space is just one

high white canvas with a lot of space, waiting for someone to come in and mold it" (15.3). The cream colored acoustical wall panels which surround the worship space are available as a place to apply the decorative art.

The volume of the space handles big splashes of color without becoming interruptive to the celebration. Figure 22 illustrates the fifty foot long mountain mural that was in place during much of my research stay. One parishioner stated that such a large decoration was appropriate because Light of the World is "at the base of the mountains bringing forth the light of the world" (14.8). Seemingly an inappropriate liturgical art subject, the mountain mural does fitting relate to Light of the World's position next to the mountains.

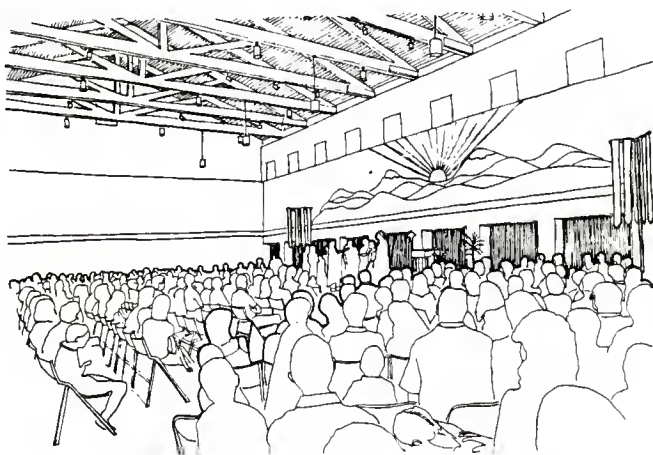

Figure 22: Mountain Mural--Worship Space

Another example of the visual impact from these wall decorations was on Pentecost Sunday. The Sunday before I arrived at the parish and the worship space had a color scheme of dark blue, light blue, and yellow placed as streamers in different parts of the space. On Pentecost, just the next Sunday, the space had been changed to a color scheme of yellow, orange, and red. Additionally, at the wall above the altar was a red and yellow banner which hung from the wood ceiling to within eight feet of the floor. The middle part of the banner was a vertical red cloth with large yellow letters spelling out alleluia. Radiating diagonally from this vertical red cloth was six yellow fabric panels. The image was spectacular and set the tone for the worship service. Experientially, the importance of this decoration is how the space can be dramatically changed over a short period of time.

Using just strips of colored fabric for a decoration, however, had one parishioner upset because he did not see any intended meaning in the object. He said, "I think these (colored) banners that are on this aluminum pole they don't mean anything" (14.7). In contrast, the mountain mural had a meaning through the church's close association to the mountains, but the simple six-inch wide colored cloth strips had no meaning and so should not be used. The use of color, however, can create changes to the mode and character of the space, as was the case with Pentecost, which indicates the

appropriateness of these decorations. Upon close examination, quality exists in the materials and construction of these parishioner sewed banners.

What also drew a misinterpretation was the use of flag banners outdoors. Figure 23 illustrates these festive flag banners that are placed adjacent to the sidewalk for special liturgical celebrations. The purpose of these banners is simply to add excitement to a special worship celebration or event. Such non-traditional art, however, also created a question as to its underlying meaning. One parishioner said, "it made me feel good that they were pretty and bright and waving in the wind, but I was sure there was suppose to be another reason" (9.8). The need for the art to provide meaning or symbolism appears to be important.

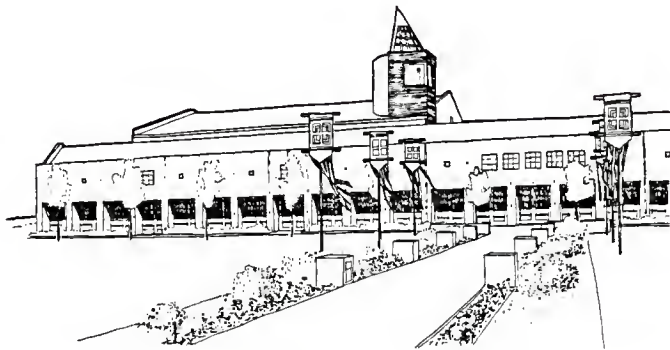

Figure 23: Flag Banners at Main Entrance

In any discussion of art, the matter of esthetics is partially a subjective response coming from each individual viewer. One piece of art has, however, received attention because of its implied unauthenticity. Above the baptismal font is suspended a candle mobile that the liturgical artist describes as representing natural symbols of air and fire (Buscemi, 1987). The placement of the mobile makes it more visible upon leaving the space than entering, which when coupled with the disuse of the candles destroys its validity. As two parishioner's commented, the candles are never lighted, why then is the mobile there (8.12) & (14.10). Without using the candles the meaning, liturgical support, and appropriateness of the art is gone.

In contrast, the tabernacle represents an art form that received high praise for its quality and appropriateness. In comparison to the mobile, the tabernacle is placed in a very visible location. Located in the eucharistic chapel, it is positioned on axis to the main entry doors. The special artistic qualities relates to the use of etched glass panels placed in a leaded frame which mimics the proportions of the chapel room itself (1.35). The semiclear glass indicates an openness between the host's, which reside in the tabernacle, and the person in the chapel. The total concept develops a symbolic connection between Christ and the people of the parish. This experiential feeling of mystery supports the appropriateness and hoped for result of

the art object.

The third item of liturgical art significantly important to the parish is the courtyard cross. Even though some people feel that this cross is removed from their attention it is one of the most profoundly adored items in the parish. The parish reproduces images of the cross to convey a specialness to other people. For example, a miniaturized sculpture of the cross was made into a necklace and presented to a parishioner who was leaving for missionary work in Africa. Another example was when the pastor used a photo of the cross as a christmas card. While the workmanship is not as delicate as with the tabernacle, there is a measurable lack of genuineness as an unfinished image. The tests for both quality and appropriateness are not completely answered.

Another important group of liturgical elements is the altar furniture. The altar as the common table of the assembly is placed in a central location of the worship space. EACW calls for the altar to be constructed of high quality materials having a simplicity in design appropriate to serve as the place for the more primary symbols of bread and wine. The simplicity is present through its simple table form of slab, table legs, and cross bracing support, yet its quality and specialness comes from its selection of material--cherry wood--and exposed mortise and tenon detailing. As one parishioner stated, it is a work of art

worthy to be the altar. He expressed the beauty of the furniture when saying that the furniture had "strength yet also simplicity" (8.9).

This same furniture construction occurs for the lectern, presider's chair, tabernacle support, and chapel altar. All use the same cherry wood material and intricate exposed joinery that provides for an integrity between the furniture. Unfortunately, several smaller tables are periodically used which do not have this same high level of craftsmanship and distract somewhat from the overall integrity of the furniture. This situation, however, was never mentioned by any parishioner and represents an aesthetic opinion on my part.

Along with the liturgical art, an issue of quality and appropriateness in building materials is important to discuss. The architects selected materials that, while having lower cost, were still authentic. This meant that quarry tile floors, brick walls, and hardwood platforms were specified in place of sheet vinyl that looks like tile, concrete block that looks like brick, or plastic laminate that looks like hardwood. As was identified by the architects', the manner of how these simple materials were detailed contributed to their special quality (1.33).

Additionally, these materials seemed to be appropriate for Light of the World. Materials like marble or terrazzo would not have been appropriate as they would have diminish-

ed the warmth and home-like setting of the building. The warmth of the worship space comes in part from the exposed wood ceiling. This selection is more appropriate than one which would have created a white acoustical surface. It is precisely these issues that clearly show a consciousness by the architects to develop quality and appropriateness throughout the building.

The one detriment mentioned by a parishioner is the required maintenance for the exterior wood doors and windows. He indicated that because of exposure to the weather, these doors and windows had to be refinished yearly (13.15). Even though refinished on a yearly schedule, the doors and windows after four years show signs of decay that will require quicker replacement than any other item on the building.

Overall a quality and integrity in Light of the World's selection of materials, furniture, and art work has occurred. A critical aspect is how parishioners have been involved in the design, development, and placement of liturgical decorations in the worship space. The appropriateness of this parishioner created decorative art as it contributes to a person's sense of wonder and community ownership will be discussed in the following two chapters.

Comparisons

When compared to the ideal of the "environment" theme as interpreted from EACW in chapter three, Light of the World is on target in critical areas. The worship space is a simple one-room space in the domus ecclesiae archetype of a meeting room. The formal structure supports this characteristic through its volumetric proportions and built form. Importantly, the architects have established a formal structure typology, that is acceptable to the parishioners while at the same time contemporary in scope. The north wall of the church is, however, an exterior element which created negative feelings. Several parishioners questioned its meaning and why it had to be constructed as a blank wall.

One important aspect at Light of the World is how the physical form and placement of the building helps to establish a presence in the landscape and region. This type of identification has made the building a landmark and public symbol. Another important design solution is the placement of the church entrance on the south side of the building. It is that part of the site which offers the best views to the mountains to the south and west and has provided special experiences for parishioners.

Initially the most noticeable contemporary characteristic of Light of the World is the formal geometry that is articulated in the many repeating square patterns at the

exterior of the building. Such highly regulated geometry draws attention to the physical form. This geometric pattern draws attention to the worship structure typology of vertical tower and horizontal gallery images.

One important statement in EACW relates to the exterior physical structure. The document stated that these new worship environments are not to impress or create dominance. Instead the call is for the development of human scale and unity. Unity refers to the honesty and completeness of the building. At Light of the World unity exists through the use of the same materials throughout the building, which develops a sense of wholeness for the structure. This unity is best exemplified by the exterior brick pattern which wraps around the building. The formal geometry of the building establishes a level of completeness not present in many buildings.

A most important quality about Light of the World is the relationship to human scale which reduces the building's dominance. Several design features have enhanced this sense of human scale. First, because of the organization of the site plan, which created the formal entry path to the building, vehicles are selectively excluded from the building. Instead the building is approached by foot allowing more time to observe the building as well as to communicate with other parishioners. There is less of a sense of urgency in walking and more time is spent on the

gathering process. More importantly, though, is how the mass of the gallery roof effectively screens the bulk of the worship space from the people as they enter.

Human scale is also found in the interior where many ceiling soffits are seven feet above the floor, easily touched by an average adult. The worship space itself supports this human scale by providing chair seating instead of the more traditional pew seating. Instead of sitting within a seating area that extends for several feet, chairs set up definite spatial limits for each individual.

In EACW, the concept of having a gathering space for the assembly focuses more on the worship space than any other area of the building. At Light of the World the notion of gathering in the worship space has not been fulfilled simply by providing a space large enough to accommodate a lot of people. Rather, the space attains this status through how the furniture, flexibility, and visual openness creates the sense of gathering through comfort as well as feeling at home in the space. A temporary problem does now exist with the inability to handle large crowds of people.

The true test for the environment theme is how well the people of the parish can gather as community. Central to Light of the World's design was the planning of spaces which encouraged group gathering. As an example, a parishioner arriving at the church must travel through the foyer, which

causes them to come in contact with other parishioners. The courtyard is the one space which is not completely supportive of gathering because of its dual spatial patterns. The worship space promotes gathering through its openness and flexibility which encourages alternative uses of the space, it is like the family room of home where everything takes place. Experientially, the worship space at LOW has been described as a comfortable and enjoyable place to gather. Parishioners mentioned ways in which they have felt special, such as when they received a smile from another parishioner in the space.

The decision to use parishioner artwork and decoration to support the worship celebration is one of the most significant elements of worship at Light of the World. Designing, constructing and installing these decorations involves many people. This involvement creates a strong sense of community ownership which enhances the sense of gathering as a community.

Considering the lack of attention by EACW to architectural form, it is quite easy to believe that other less meaningful worship space's than Light of the World could be designed. The amount of flexibility provided by EACW in the eventual design of the worship structure can promote confusion concerning how the worship space enhances a gathering worship experience. What must not be lost in this period of time, as post-Vatican II worship space evolve, is

people's inherent resistance to move too quickly from a previously accepted existence. Light of the World represents a quickening of this movement, but has retained important physical elements such as the tower, to develop a contemporary architectural response to the changing environmental character of worship in the Catholic Church.

* * * Participation and Community Patterns * * *

This chapter focuses on the physical and experiential qualities of encounter as found at Light of the World and compares these qualities with the earlier interpretation of EACW. The first four sections of the chapter look at the qualities of encounter as found at Light of the World Catholic Church. The initial two sections--"worship participation" and "personal and communal spaces"--explore the theme's physical attributes. The next two sections--"sensory contributions" and "movement, gesture and posture"--explore the theme's experiential attributes. The last section compares these attributes to EACW.

Encounter most generally represents active human interactions which occur in the worship lifeworld. For the post-Vatican II Catholic Church, such active interactions come from a person's complete involvement in the liturgical celebration. Importantly, encounter exists through regular and weekly worship gathering with other people. EACW describes this interpersonal contact as a gathering of the faith community which requires both personal as well as communal worship experience. It is also the gathering place that establishes a common context for involvement of the assembly in the worship space.

EACW recognizes, however, that worship regularity alone

does not create human interaction. Rather, a fullness of the worship experience is inherently based on sensory, movement, gesture and posture experiences. In fact, these factors help develop a complete experience within the worship lifeworld and represent a main characteristic of the encounter theme.

The discussion in this chapter evolved out of interviews with parishioners as well as my personal experiences. Parishioners consistently mentioned in their interviews how they participate actively in the worship celebration. Through describing this active participation, parishioners would express how experiences in common with the assembly affected their participation. Observations of the worship environment during my first two weeks at the parish helped to establish a focus on sensory and movement experiential factors.

Thus, this chapter first looks at worship participation. The initial concern was to describe ways in which the physical structure supports the expressed active participation. Parishioners' individual and communal experiences within the worship space are discussed in the next section. In the last two sections issues derived from sensory, movement, gesture, and postural experiences are presented.

Worship Participation

Prior to Vatican II, the experience of worship had been primarily an experience of personal devotion. It was anchored in experiencing the liturgical celebration as it took place remote from the place of the congregation (Malarcher, 1978). Any sense of participation occurred only in a figurative sense. The post-Vatican II worship experience is identified by EACW as an active participation of the assembly in worship. EACW discussed how this active involvement of people in the worship celebration comes from experiences of the gathering community.

Collins (1984) suggested that people can respond to their worship world in two distinct ways. One way is when the worship space is merely "observed", the other way is when "people perceive and participate in what they experience" (Collins, 1984, p.332). He reasons that many worship spaces are experienced without any participation because the worship liturgical celebration is merely a weekly exercise--not an encounter with other people.

To achieve this active encounter, Debuyst (1968) proposed that worship spaces should be modeled after a home environment, because such spaces promote the interaction with other people. He was concerned that an auditorium-like space caused people to passively sit back without any interaction with other people. He determined that the worship environment should be a place for the assembly which

has a "real interior" (Debuyst, 1968, p.30). This genuine interior space was to be a humane and hospitable place which would inspire authentic words and actions. The key question is to determine what spatial organization would create this hospitable environment.

Diekmann (1980, p.49) explains that for participation by the assembly to occur in the post-Vatican II Catholic Church, the old spatial patterns which are based on a "two-room church" must be replaced with a spatial organization of a "one-room space". He states that particular attention following Vatican II needs to be focused on how active participation occurs in a true domus ecclesiae archetype. He expresses alarm in the design of new worship spaces which in pretending to follow the guidelines of EACW are, in fact, designed in the two-room spatial pattern associated with pre-Vatican II domus dei churches.

This concern for churches that are classified as following post-Vatican II principles but are really a traditional two-room space having a modernized look is one of the critical problems facing the design of post-Vatican II churches. As an example of this problem, Figure 24 shows a plan of a Catholic Church, also in the Denver area, which was designed and constructed during the same period of time as Light of the World. While the structure is organized in a non-traditional modern morphology of a circular seating pattern, the design explicitly retains the old topology

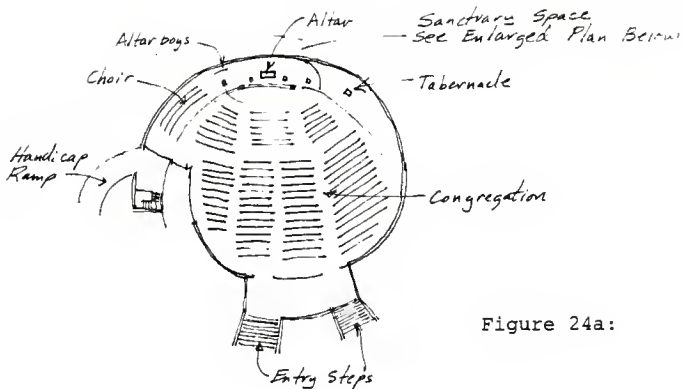

Figure 24a:

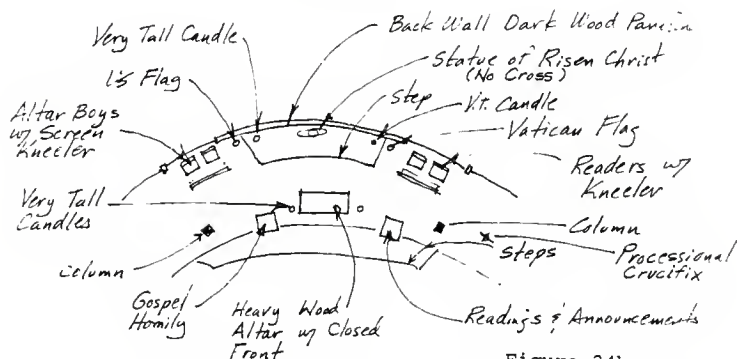

Figure 24b:

Figure 24a and 24b: Floor Plans--Denver Circular Church

of nave and sanctuary through its location, ornamentation, and psychological separation between the spatial nodes of the two spaces. The worship space is really dressed in the clothes of a modern architectural form while the basic constituents of the space still represents the domus dei archetype. One Light of the World parishioner, who had been

a member of this church, explained that a feeling of isolation from other members of the assembly was present when attending a service (5.2). He indicated that his experience of worship was as an individual rather than any experience of participation with the assembly (5.3).

In contrast, Light of the World is organized with the sanctuary space integral to the congregational space which creates one large room. Three physical elements help integrate the sanctuary and nave as one space. First, the worship space is designed to be totally flexible. Second, an openness, proximity, and accessibility exists between the congregation and the altar area. Third, the use of movable seating and movable altar furniture reinforces the openness, flexibility, and accessibility of the space.

Flexibility is seen to exist primarily through the ways the space can be arranged for different liturgical services. While this need for flexibility was a design requirement, the true test of its effectiveness comes when the parish does, in fact, change the space throughout the year. This design flexibility of the worship space helps to create active participation in two major ways.

First, each time the space becomes rearranged, people have to find new places to sit which causes them to come in contact with new people. Light of the World emphasizes this opportunity for interaction through actions of seeing, speaking, and touching as well as giving attention to people

who are sitting next to you at a worship service. Additionally, such short interactions often lead to conversations and friendliness between people when they meet at some future time.

Second, changing the spatial arrangement of the furniture requires parishioners to become spatially re-oriented to the worship space. This new encounter with the space helps to eliminate a passivity towards the experiences of worship, that can occur when a set routine is followed over a long period of time. Importantly, this reorganization of the space coincides with the changes of the liturgical seasons which gives even added emphasis to the experiential aspects of the new encounter.

This much flexibility can, however, create so much change that a person may feel out of place, lost, or disoriented. While this issue was not directly raised by the parishioners interviewed, it can be assumed that people who no longer attend Light of the World and favor a more traditional worship environment could have felt this way. Future research could be focused on comparing worship lifeworlds in which one has movable seating and the other fixed to determine the extent of this effect.

At Light of the World, the openness of the altar to the congregation offers a feeling of ownership by the assembly to these two spaces. Schlichting (1983) questions whether ownership by parishioners really exists in many churches.

She states that "if the worship space is to enhance the liturgical experience of the community, it must truly belong to the community" (Schlichting, 1983, p31). One answer for acquired ownership may be in the accessibility of the altar area to the assembly. Sovik (1973, p.86) states that the altar should "be located where it can be sensed to belong to the whole gathered community". He not only calls for the altar area to be open and accessible, but also for the close proximity of the altar to the assembly. This spatial proximity, when combined with openness and accessibility, furthers a message that the assembly not only is a part of the liturgy, but also has an ownership in the liturgy.

At Light of the World the altar area together with the seating is movable. This ability to relocate the altar area to a completely different part of the worship space clearly supports the stated desire for flexibility. What is unique, however, is the marked contrast to, other new post-Vatican II worship spaces which have generally designed as a fixed altar area with special attention to altar-sanctuary placement, ornamentation, and spatial enclosure.

A fundamental physical characteristic at Light of the World, then, is how the altar area and congregational area is created as one space. As you experience the worship space it is clearly a one-room space. It is this open and flexible one-room space which appears to encourage active participation in the worship celebration. While it is

possible that some parishioners do not believe the space provides this quality, it was found to be true with those parishioners interviewed. This characteristic, therefore, represents a major architectural element to be found at Light of the World.

Personal and Communal Space

EACW states that a personal as well as communal worship experience is critical if an active worship participation is to happen. This idea of personal-communal worship is achieved fundamentally through the action of gathering together as one unified assembly. At Light of the World the key ingredient for attaining this personal-communal experience is how the physical structure directs communal worship by individuals.

Physically, the primary building areas at Light of the World that enhance this community action are the worship space, foyer, and courtyard. As one parishioner stated "the building enhances the concept of community" because the building was designed to accommodate the people of the parish (13.20). Every parishioner agreed that the foyer space represents the best example of how the parish consistently use a non-worshiping gathering space in the development of parish community. The important personal-communal quality is how people can make connection with each other.

As one parishioner explained, the foyer was designed so that people could "meet and gather before church (and) it does that well (8.34). It is the ability to share your everyday life existence that is so important to the personal and communal experience.

While the foyer and courtyard provide the parish with non-worship gathering spaces which promote community development, the design of the worship space also furnishes people with the personal-communal experience. The spatial characteristics of this one-room space was shown in the previous section to promote active participation by the people of the assembly. In addition to this active participation, the worship space generates a sense that everyone is gathering as one unified assembly.

A critical physical condition that causes this sense of community is the use of chairs instead of pews. By providing chairs the congregation believes a special closeness is created between people. As one parishioner indicated, without pews the space "encourages you to come in and talk" to other parishioners (5.18). This develops, as many parishioner's noted, a relaxed atmosphere where people feel close to each other.

In these types of encounter experiences, an individual is reacting to their own spatial experience as well as the experience produced by the other people in the space. Tuan (1974a) describes such situations as being developed from a

combination of personal and group experiential spaces. He explains that group experiential space is dependent upon proximity to other people. Stating that such a space is comfortable when one does not feel constraint or crowded, but when having people together enhances the event that brought those people together. Independent in spatial experience, Tuan (1974a, p. 224), describes that personal experiential space is structured through our "perceptual equipment, experience, mood and purpose of the human individual". He explains that a person becomes aware of their surrounding space through how they perceive and use that space. It is the combining of these two experiential aspects that follows the recommendation for post-Vatican II worship spaces.

An example of this type of combined encounter is at the beginning of the worship service when each member of the congregation introduces themselves to people in their immediate vicinity. The action of greeting a potential stranger requires an individual to use their sense of sight, hearing and touch. This simple task of a handshake, smile and voiced hello establishes a personal contact and a common context for worship as an assembly.

The assembly becomes, therefore, a group experience where each person has an individual experience which occurs in harmony with everyone in the assembly. Possibilities of discomfort for the more introverted parishioner may exist,

however, with this type of experience. It is, though, the very action of this community unity which would create a sense of comfort.

At Light of the World, a personal and communal experience within the worship space also exists because of the great number of parishioners who provide lay ministerial support at each worship service. In fact, one of the most significant qualities found at the parish was the quantity and quality of this ministry. At each service two altar servers, three readers-commentators, ten to twelve eucharistic ministers, six to eight hospitality ministers, and ten to twenty musicians/choir--a total of thirty to forty-five--become the most obvious participants.

The design of the worship space as a flexible space, through the use of moveable seating also creates other opportunities for personal and communal experience. The flexibility of the seating does not restrict movement and places people in visual proximity to more people than would fixed seating. This added openness to the space also increases a feeling of togetherness between people. As one parishioner stated, "after Light of the World I have gone to churches with pews and I feel confined and separated" (4.11).

Additionally, the use of movable seating becomes a conscious response for accessibility by every member of the parish community. Figure 25 illustrates an important

example of how, at Light of the World, a person can locate themselves anywhere in the worship space, even if they are in a wheelchair. By simply removing a few chairs an honest statement concerning how everyone is welcome to the communal celebration is made.

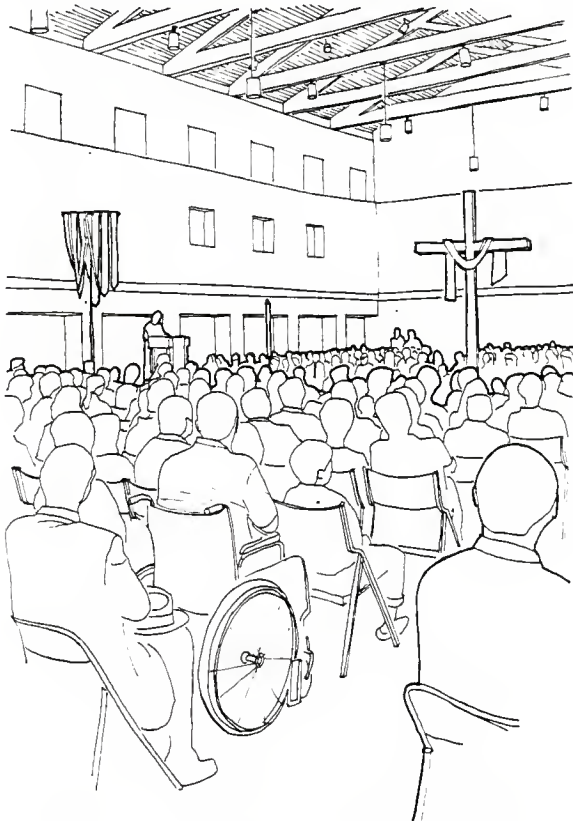

Figure 25: Wheelchair in Worship Space

A worship space having pews would, in contrast, require this person to locate themselves in a spot designated just for wheelchairs. Light of the World has gone beyond just accessibility for handicapped members of the parish; they allow that person to have the opportunity for choice, usually with the added benefit of sitting with their family instead of by themselves.

While accessibility for a handicapped individual is important, so is the participation of the total parish community. One example is the development of a monthly liturgy which encourages children to become part of the total parish communal experience. This liturgy, identified as a family liturgy, is organized so that children may perform a skit, puppet show, or assist the presiding minister in the homily. As a parishioner noted, children become major active participants in the worship celebration (8.46).

The physical organization of a one-room flexible worship space becomes a primary support element for how Light of the World has created experiential encounters which are personal and communal. This characteristic is significant in consideration that most Catholic worship spaces use the more traditional choice of fixed seating and altar furniture.

Sensory Contributions

EACW recognizes the importance which senses have in determining how a space is experienced. The document focuses on the aspect that for a full worship experience there exists the need to use all of a person's sensory capacity. Tuan (1974b, p.10) states that a person "perceives the world through all his senses simultaneously". He suggests that the reason why some spaces, like a skyscraper, do not reveal their essential identity is because these spaces do not demand activity by all our senses. In contrast, he says that spaces which give us the most stimulation are those where a person's experience involves the use of all their senses.

At Light of the World, key elements of the physical design, spatial organization, and structure of the liturgical celebration encourage the use of a person's full sensory capacity. A person's experience of sight in the worship space has contributions from natural daylighting, a visual projection system, and short viewing distances. The worship space, typical to most worship spaces, has an amplified sound system which supports a person's experience of sound. Sensory contributions of touch are present through the physical design of the space as well as through ritual actions of worship. Additionally, this ritual action of the liturgical celebration also includes the sensory contribution of taste and smell.

For sight, EACW discusses that quality viewing comes from a sense that what you see as a member of the assembly "is proximate, important and personal" to your worship experience (Bishops Committee on Liturgy, 1978, p.28). At Light of the World one method to increase this sense of visibility within the worship space was to create a higher level of illumination. Through glass block clerestory windows an exceptional amount of natural daylight is introduced into the space. When compared to an application of stained glass windows, typically found in a worship environment, Light of the World creates a unique experiential factor for worship space encounter. Parishioners now encounter a space that is not only an open flexible one-room space but is also visually open through the increased illumination in the space.

The only problem in which parishioners stated a need to reduce the lighting level was to allow, in the daytime, slides to be shown during the worship service (8.15). Even though parishioners' previous worship experiences included churches that had created a sense of mystery because of low illumination levels no parishioner expressed a desire to recreate that type of atmosphere at Light of the World. One parishioner did, however, wish that Light of the World would have a midnight mass, because of the mystical low light levels associated with that service (7.14).

The clerestory windows, while providing an increase

level of illumination, also establish a pattern of light which has an exciting quality as it refracts into the space. This phenomenon can create special experiential qualities. As an example, one Saturday evening during a worship service the light coming through a single three-by-three-foot western clerestory window seemed to reach every corner of the worship space. The light actually appeared to bend into the farthest reaches of the space illuminating everyone in the assembly. An extra sense of specialness came at the end of the service when, as if liturgically timed, the sun moved behind a cloud and dimmed the natural daylight coinciding with the closure of the service. Parishioners recognized how the amount and quality of this natural lighting is special to the space. One parishioner recalled how the sunlight coming into the space on Easter Sunday illuminated key elements of the decorations which made her feel that a specialness existed in the space (4.33).

An increased level of illumination supports the sense of sight in other ways. The Pastor recognized that a softness within the worship space comes from this natural light reaching into the space (2.20). This feeling of comfort with the worship space not only is a result of the natural daylighting but also comes from the use of a light interior color scheme.

Even though the space is, physically, designed without

any eye-level windows, which promotes a sense of enclosure, the natural daylighting combined with this use of light colored finishes help to create an experience of openness. Additionally this extra illumination supports an ability to see other people in the worship space. One parishioner commented after a service how much easier it is to see at Light of the World than at other churches. Another parishioner indicated now natural daylight made him feel uplifted with less humiliation when compared to his experiences in churches with stained glass (5.43). The high level of illumination, therefore, allows parishioners to see with greater ease the facial expressions of the presider, ministers, and parishioners as well as provide special experiential encounters.

While good visibility to see expressions of the ministers should exist from anywhere in the worship space, parishioners are concerned with their distance from the principle areas of the worship service. Predominantly, parishioners feel that they are not participating in the service when they are at the farthest reaches of the worship space. As one parishioner noted, she did not feel a part of the mass and felt uncomfortable if located in the back (9.18).

The behavioral recording of how parishioners positioned themselves in the worship space supported this parishioners view. Figure 26 shows a behavioral map of the worship space

just prior to the start of a service. Typical as to what was found on several occasions, parishioners position themselves in the center of the space towards the altar area. This orientation towards the center of the space brings people closer to the liturgical celebration which encourages active participation.

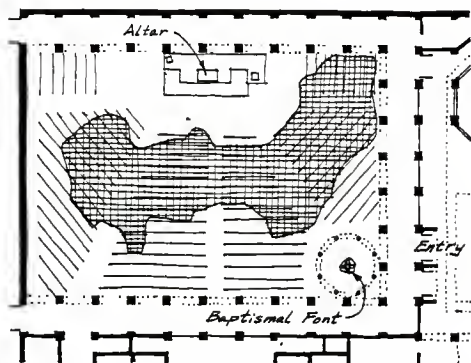

Figure 26: Worship Space Behavioral Map

A design idea rarely used in other churches, is the use of a visual slide projection system during the worship service. The visual projection system introduces sensory contributions of sight as well as sound. This system is used to project song lyrics and common prayers of the assembly onto the north wall. Two critical experiential conditions result from this action.

First, by projecting the song lyrics the need for song-books is eliminated. Additionally, since major common prayers of the service are also projected the need for missalettes is also eliminated. This means that the worship space is not visually cluttered with song-books or missalettes. This lack of visual pollution creates a more visually pleasing space.

Second, parishioners believe that projecting the song lyrics has caused more people to sing because it is easier for everyone to follow and participate (4.31) (5.31) (10.21) & (13.25). Unconsciously, there may be less resistance to sing when only the words are projected instead of song notes. More significant, however, may be that parishioners participate in singing because the same songs are sung repeatedly because of the difficulty in making changes to the slide projection system. As a sensory contribution, however, the level of singing is high and there exists an encouragement for people to sing. The associated pastor felt that people are more encouraged to sing if a church does not have a strong choir. He felt that a strong choir causes people to be more inclined to listen (3.8).

Importantly, music does provide one of the primary experiences of sound. The critical factor at Light of the World is the manner in which the people sing. While in some churches the choir group sings more as a stage performance, the musical ministers at Light of the World create a sense

of supporting the total assembled group in singing. As one parishioner said, "the music here is at a tone where everyone can sing, it is not overpowering" (14.19).

Besides music, other sensory contributions concerning sound exists in the worship space. One parishioner, who expressed the general view of all parishioners interviewed, stated he was "extremely happy with the sound quality and the ability to hear anywhere in the space" (13.25). He felt that money was well spent on the microphone and speaker system. Another parishioner said it did not matter where you sat in the worship space you were able "to hear everything--the music, readers, and minister" (4.29). While the amplification system produces good clear distinct voices by people using the microphones, a key element in a parishioners experience with sound is the formal structuring of the ritual worship service.

As expressed in EACW, the worship service is based upon a polarity of experiences where silence occurs in contrast to voice and music during parts of the worship service. These silent pauses contribute greatly to the sensory experience as well as supporting qualities of reverence, wonder, and transcendence. As an example, on one occasion when I was sitting next to the baptismal font, at the silent pauses of the service I could hear the water flowing in the font. This experiential interlude was a stimulant to reflect upon the sacramental qualities of baptism.

The presence of interrupting sound, however, is a problem when a parishioner wants to experience an individual silence. The Pastor related that because "the whole building is open, noise becomes a problem for private prayer" (2.17). He explained that churches need to be designed not only for the assembly which requires an open experiential type of space, but also so that people can experience silent devotion (2.18).

Several tactile-touch experiences occur as part of most worship experiences. These include a person's tactile feel of different floor, wall, door, and furniture surfaces. At Light of the World, these types of tactile sensory experiences existed but did not provide a major experiential contributions. What was important to experiencing the worship space was how the sense of touch occurred in combination with a person's other senses.

One of the most striking examples of this sensory combination was the experiences that occur during communion. As one approaches the presiding minister or eucharistic minister the worshipers eyes meet their eyes and without speaking there is a feeling of connection. Not only does the communicant see this person and feel connected to them they also see the sacred host and, then, touch it and taste it. At Light of the World a communicant also sees the wine, placed in a clear vessel, which allows the ruby red color to penetrate their mind and then they touch the vessel

and taste the wine. These two series of multiple sensory contributions combine sight, touch, and taste in a time span of forty-five seconds, is also accompanied by the sound of the singing congregation and smell of burning candles. This experience is good example of all the senses working to create a full experience of worship.

Other visual-tactile experiences occurred which relate to a multiple-sensory contribution. As an example, at the beginning of the Pentecost service, the presiding minister moved through the congregation blessing people by using a cedar tree sprig. The visual connection of the evergreen branch and the tactile feel of the water was like morning dew dropping from a living tree branch in the forest. Another visual-tactile experience occurred through the placing of oil on the back of the hand.

These examples represent how Light of the World creates a fullness in a person's sensory capacity which leads to a more active participation and connection in the worship celebration. Of course, the ritual structure of Catholic worship provides the major opportunity for this multiple-sensory contribution and is not limited just to Light of the World. The important issue is that all sensory experiences, including those directly attributed from the natural daylighting and visual projection system, must continue to be a part of worship lifeworlds.

Movement, Gesture and Posture

The Catholic Church has always been rich in its tradition of liturgical movement, gesture and posture. EACW states that these "common symbols" impact upon us "visually, environmentally and bodily" (Bishops Committee on Liturgy, 1978, p.30). Additionally, EACW identifies that the highest level of experience in a post-Vatican II worship space occurs through the actions of the assembly. At Light of the World the ways in which these common experiential symbols of movement, gesture and posture support this action of the assembly is special.

Two significant elements occur at Light of the World which reinforce the assembly's action. First, the physical design of the building has affected the manner in which these common experiential symbols occur. Architecturally, both exterior and interior spaces are found to support these experiential actions. Second, the parish has established a particular manner for worship which gives added support to the assembly as the primary symbol of community. Experientially, there exists a specialness in how these common symbols occur during the liturgical celebration.

Movement seems to be one element which people realize they perform, yet don't necessarily understand how it impacts them experientially. A good example is the movement which occurs in a parishioner's arrival to the building. One parishioner answered abruptly, thinking it was a silly

question, that she just drives up, parks her car, walks in and sits down in the worship space (9.19). While this was a typical response, one parishioner did remember that his arrival process starts when he leaves home. He saw the entire process as quite significant in the overall preparation for worship (5.39). What became apparent with each parishioner was that they all move into the building along the same center sidewalk (4.18) (7.9) (10.24) & (15.17).

It is the building's design of a central axis entrance which establishes a set pattern for arrival. This design feature creates a single gathering point for entrance into the building and was not an arbitrary decision. The architects explained that the liturgical consultant had continually insisted that the gathering-arrival process, which starts before a person actually comes to the building needs, to converge to a single entrance place (1.38). The design, thus, has created an encounter point for the assembly, experiencing an action gathering for worship.

One of my first experiences was viewing this movement of the community into the building. People moving from the parking lot were funneled into an animated procession of parishioners which ended at the building's entrance. Figure 27 shows this pattern of people, as viewed from the building, starting out as an individual spatial experience at their cars and, then, becoming a group spatial experience as the parishioners reach the entrance.



Figure 27: Parishioner Arrival from Parking Area

The next major link in the arrival process is the foyer space which serves as an important element in the movement process. The location of the foyer makes it a connection between the exterior and the worship space. Because the worship space is not located in a direct path from the exterior a parishioners movement is physically interrupted before arriving at the worship space. Importantly, breaking up of the arrival process increases chance encounters with other members of the parish.

At Light of the World the foyer space was designed to promote gathering. Even before the start of a worship service a number of different activities can be taking place concurrently in the space. As one parishioner indicated when explaining her movement and arrival process, "right after entering the front door I stop and scan the foyer to see who is there, such as the coffee people, a cluster next

to the sacristy waiting for the pastor, the scatterers that just meander, then there are those that knock me down when I am scanning" (6.16). Such labeling of people's different activities indicates a degree of encounter activities which are occurring on a regular basis. As a place designed for gathering, movement which occurs by parishioners through the space establishes a weekly connection between people of the parish.

After the foyer space, parishioners enter the worship space. The special qualities of movement occurring in the worship space are derived from two different sets of particular circumstances. First, the ability to rearrange the space leads to changes in how people move into and within the space. Second, the movement of the ministers while performing their service to the assembly establishes a dynamic symbol of a unified community.

As was explained in the previous chapter, the seating at Light of the World is completely moveable. Each time the seating is rearranged in the worship space an new experience of movement occurs. Such readjusting to spatial patterns creates different experiential awareness of the space through changes in visual, sound, and tactile sensory inputs. Again, as expressed in an earlier section, these changes may have caused enough discomfort, that people who preferred the more traditional arrangement may now be attending a different parish.

One physical element fixed for all seating arrangements in the worship space is the baptismal font. The font is located in one corner of the space next to the main entrance from the foyer. The architect's indicated that the placement of the font at the entrance to the worship space was to promote parishioners contact with the baptismal waters of the font. In practice not everyone actually moves through the font area because movement is hampered by the physical design of the area.

The problem exists primarily through the architects' repetitious use of columns at the side aisle and around the font. Figure 28, a plan of this area, illustrates the placement of these columns in relation to the entry into the worship space. This diagram of parishioners' movements show that the placement of columns interrupt people's path and they turn away, taking the easier paths to the right and left. This forced decision point, however, can be recognized as experientially important because a person must consciously make their choice of movement either to or around the baptismal font. Those making the effort to pass by the font reinforce more consciously the significance that the font represents. One parishioner, in fact, recognized that a connection to the font's sacramental significance increased because of his conscious choice for movement to the font (5.27).

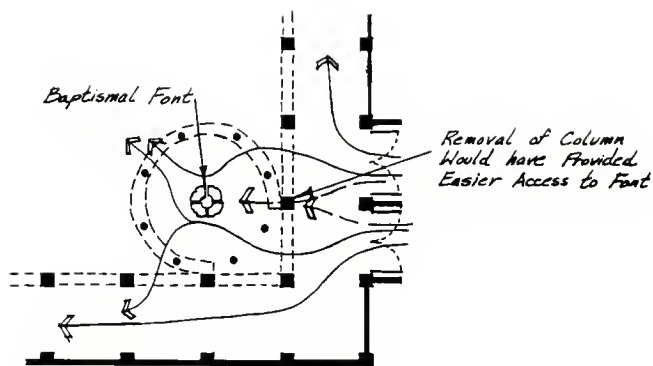

Figure 28: Behavioral Map--Movement at Baptismal Font

Within the worship space, typical movements occur through group processions at the beginning of the service and at communion. The action of movement which provided the most impact concerning the assembly's primacy as a unified worship community, however, was the movements of the readers and eucharistic ministers as they performed their worship service to the assembly. In many ways, their movement patterns are established differently than in other Catholic Churches. As a comparative example refer to figure 24, on page 123 in the first section of this chapter, which illustrated a typical psychological two-room space. Note that the readers and eucharistic ministers are positioned in specifically prescribed locations within the worship space.

In contrast, at Light of the World the readers and eucharistic ministers are not assigned to any predetermined spot in the worship space. They instead are seated within the assembly with their families and friends. While the two-room worship space shown in the example creates an implied separation between these ministers and the assembly, Light of the World, by allowing these ministers to be anywhere in the assembly establishes a truer sense of a single unified community.

Experientially, the movement of these ministers from their respective places in the assembly becomes a critical part of encounter with the rest of the assembly. The readers, upon their cue, move slowly and gracefully from their position anywhere in the assembly to the lectern. There is not a rushed hurriedness in this movement but a deliberate motion which creates quiet moments for reflection before the biblical reading occurs.

The eucharistic ministers, who number ten to twelve, also exhibit this same reverent attentiveness as they come from every part of the worship space to the altar. The collective movement of these people from all parts of the assembly symbolizes people of the community serving the community. Significantly, no special medallions or neck crosses exist which would destroy this sense of a common person of the assembly called to serve the assembly.

The eucharistic ministers, as they arrive at the altar

area break out with smiles, handshakes and hugs while the rest of the congregation is in song. They position themselves behind the altar forming a semi-circular backdrop for this part of the eucharistic celebration. Their arrangement combined with the assembly of parishioners in front and sides form a gesture of creating a unified circular enclosure around the altar. At Light of the World the gesture of the eucharistic ministers surrounding the altar is but one symbol that relates to the assembly.

Liturgical gestures of the assembly as well as the presiding minister occur regularly in the worship celebration. EACW describes that gestures done in common represent the biggest contribution to the unity of the assembly. Also, EACW states that those gestures completed in a broad and full sense support a symbolic quality. While traditional gestures of the presiding minister's upraised arms, elevation of the host and wine, and other such ritual gestures are significant contributions to the worship experience at Light of the World, it was gestures of the assembly that were most important.

One of the first gestures which I noticed coming from the assembly was a response to a gesture made by the presiding minister to the assembly. When the presider said to the assembly, peace be with you, he gestures to the assembly by extending his arms forward with palms up. When this occurred several parishioners in the congregation

returned this same gesture back to the presider. While I have not attended a significant number of different Catholic Churches, this was the first time I had witnessed such a response.

The other important gesture is when the assembly holds hands at the Our Father prayer. Each person of the assembly, which is standing, hold hands with a person next to themselves making a connecting link across the worship space. The important part of this gesture comes when the last person of the linked row extends their hands symbolically connecting to some further person or God. One person recognized the communal significance of this gesture by saying, "if you are sitting next to a stranger and you grab their hand it makes you a bit closer to them" (11.6). This same parishioner noted that "in a store you would not turn around an grab someone's hand" (11.7). This recognizes the experiential quality that this gesture makes toward creating a unified assembly.

Following the common prayer, each parishioner is asked to give a sign of peace to those people next to them. This action continues the connecting gesture of friendship and love between people of the assembly. Typically what takes place is a lot of hugs or kisses and a voiced greeting of peace is given to each other. At Light of the World the gesture of hugging is one of the special experiences that I receive which truly spoke to their belief that we are all

brothers and sisters together.

EACW states that posture in an atmosphere of hospitality must not be a marshalled uniformity, such as is associated with kneeling which most Catholics have experienced. What EACW does establish is that certain common postures of the church should be accommodated, which includes standing, sitting, and kneeling. Light of the World's decision not to have pews did not automatically eliminate the ability to have a kneeling posture, as chairs with kneelers could have been purchased.

Most parishioners stated that the aspect of kneeling was not important for a person's display of reverence at the worship celebration. One parishioner saw kneeling as counter to God's message saying, "kneeling does not put God at our level it puts us below his level and I don't think he ever intended that" (13.35). Another parishioner said that using kneelers was a "false reverence because if you are separated, as what happens using pews, you are not connecting in any way visually or physically (4.32). To her it represents a closing up instead of opening up to the rest of the congregation. The pastor stated that, in comparison to European churches, they were doing it right by not having pews (Culver, 1987). The common postures of the worship space are, therefore, standing and sitting.

The one unique posture occurring at Light of the World was how the people had to elevate their heads when singing

or reciting a common prayer together. The visual projection system, which projects words of these songs and prayers on the north wall, initiates this uplifting head posture. When compared to other situations where everyone has their head lowered into a songbook, such an eyes upward position is a pleasant change. Further, visibility to other parishioners is greater in this posture which helps create a sense of connection among parishioners. People in this position are able to feel more a part of the space. As one parishioner noted that this action allowed people to take in the building (5.31).

Comparisons

When compared to "encounter," as it is ideally presented in Chapter three of EACW, it appears that Light of the World meets most of the critical tests. The experiential aspects of the encounter theme such as active participation, personal-communal worship experience, sensory contributions, and common patterns of movement, gesture and posture do occur. The one significant missing element is an ability to allow for personal encounters, such as private prayer, within the worship environment.

While EACW does not provide specific physical criteria to accomplish the objectives of a full worship experience as expressed in the encounter theme, Light of the World's

design would seem to be a good model for establishing such a set of criteria. As identified in chapter five, the architects did follow the intent of EACW in providing a one-room worship space which follows the domus ecclesiae archetype, which has produced a communal gathering space.

The important aspect of this one-room space was in the use of movable seating and altar furniture. Several parishioners identified that it was the home-like quality of this furniture which created a sense of hospitality within the worship space. The use of movable altar furniture also helps people feel relaxed while establishing parishioner encounters and community connections. This community activity is seen by Schlichting (1983) as enhancing the liturgical celebration as well as create a sense of community ownership. Further, handicapped people, through the movement of a few chairs, can locate themselves, as per their will, anywhere in the worship space.

It is hard now to contradict the experiential advantages gained from the use of movable seating and altar furniture. This major design element of Light of the World is the prime ingredient in how people are directed to encounter new patterns of movement, position, and interactions with other members of the assembly. Further, the visual projection system for song lyrics and common prayers also represents an element that provides a special benefit to the experiential qualities of the encounter theme. This

unique system allows the assembly to look and act more as a unit, thereby increasing a sense of community.

One important issue in EACW is how personal as well as communal experience is critical for active participation to occur. At Light of the World, experiences which promote encounters with other parishioners, particularly strangers at the beginning of the service and at the sign of peace, serve to reinforce this idea of communal worship experiences. Additionally, the common action of the assembly with song, praise, and prayer further develop this communal experience. Such involved group experiential situations must not be so forced, however, or they may cause people to feel discomfort.

The contributions offered through senses, movement, gesture, and posture provide the key ability for parishioners to feel connected to the space. The special quality of natural daylighting serves not only to increase illumination in the space but also to support visibility to all areas of the space and to each other. The standard multiple-sensory experiences, common to Catholic Churches, are fully expressed at Light of the World. An example is the imaginative uses of the cedar sprig for parishioner blessing which provided a visual connection to a natural living symbol.

Importantly, the manner in which the ministers at Light of the World perform their service to the assembly is

significant to the overall active participation of the assembly. EACW identified that the most important element of the worship celebration is the sacred assembly of people. The parish's liturgical structure which has ministers coming directly from the assembly is a critical factor in developing the primacy of the assembly at Light of the World.

The true test for the encounter theme is how completely parishioners are involved in the worship celebration. The behavioral mapping which was conducted illustrated that parishioners positioned themselves central and close to the liturgical celebration. This observed action, verified through parishioner interviews, determined that a greater sense of participation is felt when people are in close proximity to the worship celebration. Thus, on even a broad basis parishioners at Light of the World are involved as active participants in their worship lifeworld.

* * * Worship and Spiritual Consciousness * * *

This chapter focuses on the physical and experiential qualities of mystery as found at Light of the World Catholic Church and compares these qualities with the earlier interpretation of EACW. The first two sections of this chapter--"worship and liturgy" and "symbols and tradition"--explore the physical attributes of this theme. The next section--"spirituality, reverence, and devotion"--explore the theme's experiential attributes. The last section compares these attributes with EACW.

Mystery relates to a person's spiritual consciousness as it exists within a worship lifeworld. Worship gives an orientation to this consciousness as one specific mode of liturgical expression. In the Catholic Church, worship is the regular gathering of the faith community occurring through an action of liturgy which has been derived from a rich historical worship tradition. These traditions have produced common symbols connecting worship and liturgy which helps evolve a sense of sacredness. This demonstrated spirituality reinforces the major qualities of wonder, awe and transcendence needed in a worship environment. Such feelings of mystery lead a person to a state of reverence and devotion, which fulfills, the need to experience a spiritual consciousness.

The divisions of this chapter evolved from interviews with parishioners, pastor, and liturgist. This chapter represented a greater challenge than the previous two because of two major problems. First, while parishioners shared beginning feelings of spirituality, the short interview times did not allow sufficient exploration of a deeper personal sense of spirituality. Second, EACW gives little attention to the issue of how mystery is experienced as well as little discussion concerning the physical requirements for worship.

The parishioners' interviewed collectively indicated, however, that liturgical celebration was a key issue in relation to a sense of spirituality. One key element of this discussion was how memory provided an important part of a parishioners sense of mystery. Parishioners had a good understanding of church traditions as well as issues concerning traditional liturgical art and architecture. Concerning symbols, the parishioners would relate how powerfully symbolic or special is a particular object or area of the building, but had difficulty in placing an associated meaning with that object or building element. The sense of spirituality, reverence, and devotion was recognized by all parishioners as one of the fundamental factors of worshipping in the Catholic Church.

Thus, this chapter first looks at worship and liturgy. The main focus is how physical requirements support the

worship celebration. Particular attention is given to EACW's lack of emphasis to these requirements. Parishioners' various insights into symbol and tradition relationships establish the next section. The last section focuses upon how spirituality, reverence, and devotion are part of the Light of the World's worship lifeworld.

Worship and Liturgy

EACW explains that worship as the regular gathering of a faith community is dependent upon liturgy. Additionally, this action of gathering is identified as the liturgy. The stated purpose of this action is "to praise and thank God, to remember and make present God's great deeds, to offer common prayer, to realize and celebrate the kingdom of peace and justice" (Bishops Committee on Liturgy, 1978, p.10). This action of the liturgy is seen, then, to support the establishment of community. Worship becomes one means by which parish community is developed.

Physically, worship requires a place in which to perform the activities of liturgy. As identified in previous chapters, worship spaces are to promote active participation as well as the development of a personal-communal experience. Further, EACW explains that the worship environment should be a comfortable hospitable space which allows all people to feel welcomed. What becomes apparent,

is that EACW describes only the social nature of the worship space yet leaves unanswered questions of architectural form and image. This issue is important because the physical image deals directly with how art and architecture expresses a person's faith in the church.

EACW provides a comprehensive view as to the philosophy and reason for liturgical art and furnishings, but only speaks generally as to the physical architectural requirements of the worship space. As an example of the text's disparity in this review, EACW provides forty-six paragraphs which reviews furnishings and objects for the worship space, but only eight paragraphs which review the architectural space used for worship.

The document's review of liturgical art for a worship space contains three specific requirements. First, while no particular style of art is said to be appropriate, all art must meet a test of quality and appropriateness or integrity. Second, art should invite contemplation to give a person a sense of the holy, numinous, or special. Third, liturgical art is not a means to capture God through symbols but, instead, art is seen as a form of human expression used in celebration of God's greatness. A person's sense of mystery is said to develop through their attention to liturgical art forms.

In contrast, EACW's review of the physical architectural patterns focuses discussion on general concerns of

human scale and hospitality. The building is described as providing the necessary skin or shelter to the more important liturgical action. The text clearly leaves open alternative interpretations as to the design of a worship space.

The architectural solutions at Light of the World represents one alternative expression in the design of a worship space. In particular, two decisions were responsible for creating this alternative designed worship space. First, traditional liturgical art objects, such as statues, stations of the cross, fixed crucifix, and highly decorative ornamentation, were eliminated from the design. Second, non-traditional physical elements, such as chair seating, clear glass-block clerestory windows, and movable altar furniture, replaced the more standard stained glass windows and fixed furnishings.

The resulting worship space is significantly different from most other Catholic Churches. Exactly how much variation from other Catholic Churches is best stated by one parishioner's first experience at Light of the World. She expresses how only through seeing, finally, a traditional liturgical art object did she have enough information to correctly identify the worship space as Catholic:

I remember my first experience at Light of the World. My daughter and I came here and there was no (outdoor) sign saying what kind of church. We were told Light of the World was suppose to be here but we did not know if this was the right place. There was no cross, no statues, no ornamentation except

for a rainbow above the altar. I thought it was, for sure, a Protestant church. No pews, no kneelers, everything was totally wrong. I said to my daughter we will leave after it starts if this is not the right place. The service started with the priest in his vestments, then, we were sure that it was a Catholic Church (15.1).

The physical differences that she saw at Light of the World did not represent a part of her memory as to what constitutes a Catholic worship space. Extremely important is how worship and liturgy, as relating to the experience of mystery, becomes tied to our collective memories of past worship experiences. Parishioners described that items such as pews, stained glass windows, statues, and highly ornamented altars represented physical elements which identified a Catholic worship space. On more than one occasion, memories concerning experiences within spaces having these features produced a fondness for that previous church. Such attachments, though, may have more to do with familiarity than with formal architectural qualities. As one parishioner stated when explaining the older pre-Vatican II styled church he liked best, "I grew up with it so I like it" (13.16).

Memory of past worship experiences which had provided a greater degree of sacredness did invoked some negative feelings. One parishioner indicated that several people told her the worship space is too bare and does not look anything like a traditional church (10.28). Another parishioner expressed that ornamentation was, for her, what makes

a church (9.11). Further, she emphasized that one should not forget completely those qualities that have brought you to this point in time.

An unanswerable question becomes whether the architectural design is too void of liturgical ornamentation. It is possible that many parishioners, who feel as the above mentioned parishioner, have already moved to another parish and were not available to express their views. Research which would compare worship spaces that have variations in the use of liturgical ornamentation is needed. The overriding majority of parishioners interviewed, however, believed that in time more liturgical art would be placed in the worship space. Further, they felt it was important to first develop a new style of worship that was less dependent upon liturgical art and more dependent upon the actions of the participating assembly.

Interestingly, the same parishioners who stated their desire for more ornamentation, also expressed their happiness with Light of the World. As one of these parishioners indicated "without a question Light of the World is the most beautiful church I have known" (9.30). On one hand, parishioners describe that items such as stained glass, statues, and ornamental altars represent some of the most remembered qualities of a church. Then, almost in the same breath, these same parishioners state that their experience of worship at Light of the World is the best they have ever

experienced. It would seem that these views represent a contradiction concerning the physical design of the worship space.

Two principle factors, however, seem to exist which reduces this contradiction. First, the ability to experience active participation in the worship space has taken a precedence over any previous experiences which occurred in highly ornamental churches. As one parishioner stated, she was never able to participate in Latin and the only thing you really could do was look at the statues (10.18). While the memory of a previous ornamented church is present with many parishioners, it is the experiential quality of active participation that seems to reduce any negative feelings concerning Light of the World's lack of liturgical ornamentation.

Second, attending Light of the World does not fulfill an obligation but rather represents a desire to attend. One parishioner explained that before Vatican II, attending church was an obligation that occurred not because of want but because you were suppose to go to church (5.36). Within the parish, the overriding view is that they really enjoy attending the worship celebration.

As one parishioner stated, "my pattern for going to church is one of preparation and looking forward to a happy experience" (5.39). This enjoyment is not based, however, upon a festive type of experience but upon a full ritual

experience. As another parishioner said, through more understanding, "I am able to see where ritual is the important vehicle through which the holy spirit speaks to us individually" (4.45).

Several issues have emerged concerning the use of liturgical ornamentation in the worship space at Light of the World. First, the decision of not providing ornamentation in the worship space is possibly an overreaction to the issue of how active participation was somehow lacking in previous worship spaces. The complete reduction of liturgical ornamentation may not actually affect active participation, rather the amount of involvement and enjoyment by parishioners in the worship celebration may be the major factor. It would seem, then, that with a retention of the same social worship structure, the addition of some liturgical ornamentation could occur. I would not necessarily conclude, however, that this would mean the use of more traditional art forms. On the contrary, the liturgical art would best represent traditional ideas in a contemporary manner.

Second, it would appear that EACW is correct in focusing upon critical issues concerning liturgical art's quality, appropriateness, and integrity in contrast to the reduced attention to the physical formal qualities. While it is clear that spatial arrangement and scale can be detrimental to a worship environment, it is less clear if

style or design really contributes to any negative experiences. The formal design qualities are best, however, when serving the action of worship rather than creating a dominant architectural image.

Symbols and Tradition

EACW states that since liturgical celebrations are expressions of the whole community, there exists the need to use a common language, rituals and symbols. The nature of these common elements are to support the action of worship. EACW explains that symbols should not only serve a purpose but also be capable of providing visual and sensory contributions to the action of the worship liturgy. These common symbols are, therefore, a connecting typology for worship and liturgy.

Conklin (1980) expressed concern that EACW considered common symbols only in this context. He stated that a symbolic communication also exists from the architectural and formal qualities of a building. He explained that architecture, itself, plays a major symbolic role. Similarly, Caemmerer (1980, p.37) said that exterior of the church building is important as a visual communicative symbol. He believed that, visually, a church must not be isolated from its environmental context. Specifically, he thought a rural church should have rural characteristics while an urban

church should exhibit urban design characteristics. The visual design would, therefore, symbolize a connection to its environmental setting. Christian sacred architecture has typically followed, though, a visual typology of tower, nave, and sanctuary rather than connecting to its regional setting.

At Light of the World, the physical design does not respect this traditional typology. The building while retaining fundamental associations to this typology has modified its symbolic typological qualities by combining ancient with contemporary architectural images. A good example is the tower, as illustrated in figure 29. The old typology of a tower is retained but modified visually through the use of a stainless steel skylight which replaces the typical placement of a cross. Further, the spatial organization of the tower, which combines an intersecting square and circle, as well as the visual pattern of the brickwork define a similar contemporary design formulation.

One parishioner enjoyed this contemporary symbolic quality, saying that Light of the World told everyone we are modern people in a modern church (10.2). Another parishioner explained that he liked the exterior image because the design is different than other Catholic Churches (13.4). It would seem that the architects have created a new visual typology. In contrast, however, was a parishioner who saw the church as having a visual connection to structures you

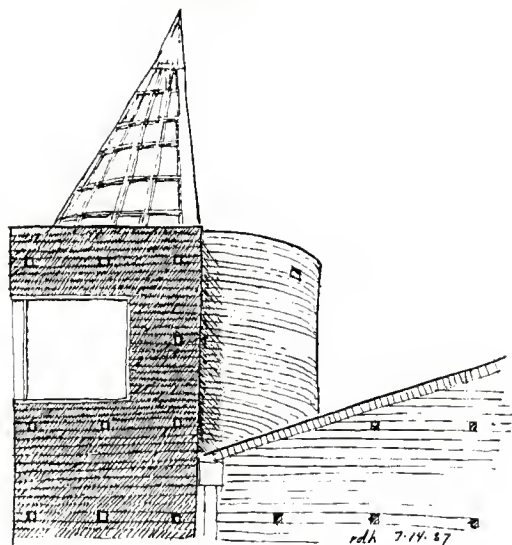

Figure 29: Tower

would find in ancient Jerusalem (14.12). The visual symbolism is, thus, seen to be both contemporary and mystically ancient at the same time.

While the exterior is devoid of traditional symbols, the interior contains expected liturgical elements that generally symbolize special qualities in the Catholic Church. Three of these common symbols--cross, baptismal font, and tabernacle--are found in every Catholic Church. At Light of the World, the differences concerning these symbols deal with design and placement.

The only fixed cross within the building is not located in the worship space but instead in the courtyard. As the liturgical artist explained, the placement of this cross in the courtyard was not an arbitrary decision (Buscemi, 1987). Rather, its position was chosen, not far removed, to confront people on their own level. The design of the cross expresses an unfinished state that represents people's need for reconciliation (ibid, 1987). As one parishioner, indicated the cross is located so we can touch and experience it in our lives (4.34).

The design of the cross as well as its location does not effectively serve or produce the results expressed by the artist. Its position in the courtyard, while at the same height, can not be easily viewed from the interior through the combination of door-window mullions and brick columns, which means a person has to hunt for its location. While the design is stated as unfinished, the use of the massive concrete pedestal foundation and steel construction has effectively created a finished art form. Figure 30 illustrates a view of the cross from the courtyard looking back towards the foyer area of the church.

The image of a crucifix still holds powerful symbolic meanings of resurrection, suffering and devotion for many parishioners. One parishioner said there was "two things he looked for in a Catholic Church, a cross on the altar and the tabernacle" (5.9). He explained that above all else

these things take his focus and indicated that for him "the cross is what the church is all about, the whole Easter experience (5.46).

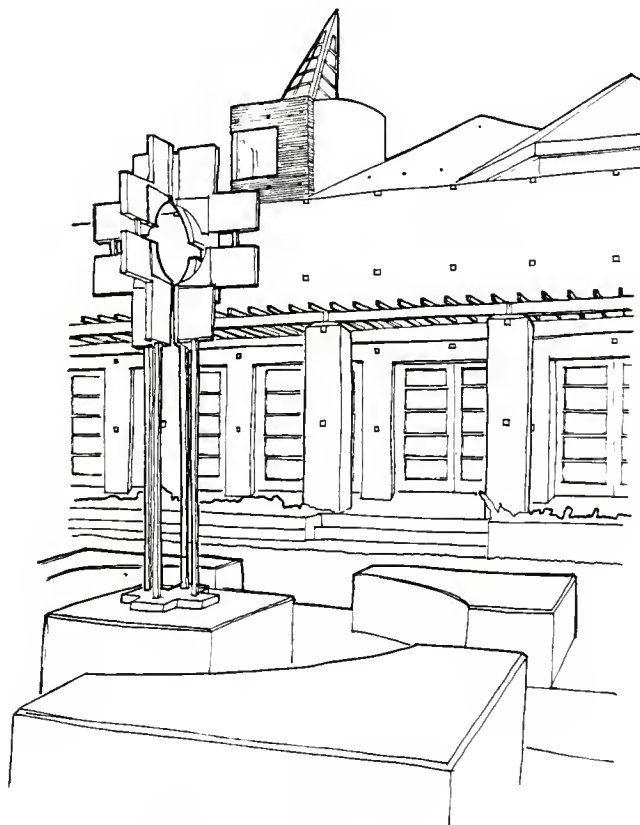

Figure 30: Courtyard Cross

Light of the World utilizes two different cross forms in the worship space. During most of the liturgical year a small portable crucifix is placed on the altar platform. During the Lent-Easter season, however, a large wooden cross, constructed by a member of the parish, is placed in the middle of the worship space. Significantly, through the use of two different cross forms a greater emphasis for the Christianity important Easter season has been created.

The tabernacle also represented a special symbol at Light of the World. As with the courtyard cross, the position of the tabernacle along with its design creates this specialness. The tabernacle is located in the eucharistic chapel on axis from the main entry doors. This position in combination with no chapel doors allow the tabernacle to be one of the first items a person will see upon entering the building. As one parishioner noted it is not hidden away but visible to everyone who enters the church. For this parishioner, the tabernacle represented the highest symbol at Light of the World because it gave her a "high spirituality and sense of Jesus" (4.51).

The baptismal font, potentially because of its prominent position as well as the only fixed element in the worship space, drew the most parishioner attention (2.28) (3.5) (4.49) (10.29) (11.3) (12.11) (13.5) & (14.22). Additionally, this element, more than any other, received the most detailed explanation by the liturgical artist. He

saw the baptismal font as serving much more than simply the place for baptism. Attached to this function was placed a refined set of natural and liturgical symbolic characteristics. The liturgical artist's words best described these characteristics.

Baptism is the entry point of Christian life. It is the source from which all ministry flows and all gifts are shared. Baptism is the sign of reconciliation, unity, and the overflowing abundance of God's generosity. The font serves to express these various baptismal meanings. The rock of the font is local to the area, and its natural contours have been opened from its center into four quarters. From this center point, the water wells up and, in a cross form, overflows in the four directions of the compass. ... The font itself sits at the center point of the tower. The circle and the square of the tower are articulated in the tile floor pattern. The font and tower stand at the entry point into the worship space. ... While the font itself expresses the four directions of the compass reading out from a center point, the tower area also expresses the four elements from which all life springs: the earth of clay tile and rock; the airiness of the tower space; the water flowing in abundance; the fire of the easter candle, a central symbol of Christ present in glory. The mobile above the font also unites the interplay of fire and water as shown in the hand-blown glass forms and in the arrangement of candles (Buscemi, 1987).

Most parishioners, however, did not understand nor could completely see these same symbolic qualities. As one parishioner stated, "the circle and square come together which seems impossible, yet it works, which makes it interesting" (6.11). Another parishioner said, "I know that we are suppose to walk through there and enter through a renewal of baptism, but it necessarily does not give me that feeling" (15.18). While they knew, through previous

descriptions, that the font was an important element of the worship space, they had difficulty in describing or feeling its symbolism. Figure 31 illustrates the baptismal font and supporting tower structure which encircles the font.

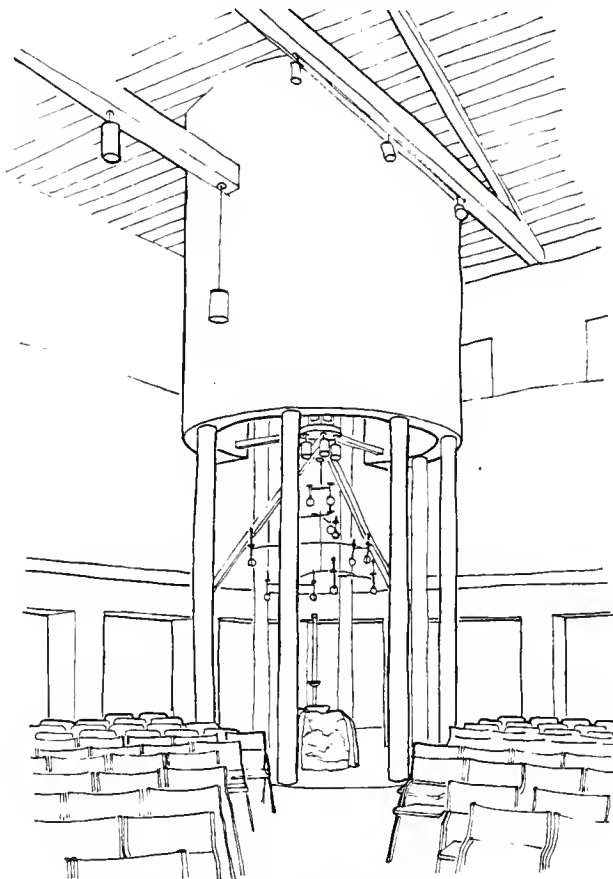

Figure 31: Baptismal Font

Even though parishioners had difficulty in prescribing a particular meaning to a symbol, such as the baptismal font, the degree of artistic involvement and symbolic meaning developed by the liturgical artist serves to provide a state of wonder or contemplation for people. In many ways that represents what EACW is asking of the mystery theme.

Spirituality, Reverence and Devotion

In EACW, the issue of sacredness continues the main theme presented throughout the document that it is the worshipping assembly which represents the most sacred part of the liturgical celebration. The document states that "the most powerful experience of the sacred is found in the celebration and the person celebrating" (Bishops Committee on Liturgy, 1978, p.18). The architectural program stated this same philosophy by saying, "we looked at the primacy of the assembly as being really important, so that the building became supportive to the individuals personal spiritual life" (Hoover Berg Desmond, 1981).

It is highly speculative, though, to believe that the physical space becomes responsible for creating a person's spiritual sense. What can be explored, however, are the experiences concerning people's spirituality as it existed within Light of the World's worship lifeworld. Several parishioners expressed that a sense of spirituality did

derive from the action of the assembly. As one parishioner said, "the spirituality abounds out of the community, it is the genuineness of the people, it is with love that they approach you, a caring feeling and not (just) a passing feeling made on Sunday morning" (7.23). Another parishioner stated that "the spirituality increases because of the community action" (4.40). In both cases the parishioners were responding to personal feelings of happiness which comes from the interaction with other people.

The issue of spirituality concerning the building has created a variety of responses. The chapel was the space which overwhelmingly represented an experiential sense of sacredness. For one parishioner the chapel was sacred because it was conducive toward intimacy (5.47). Another parishioner explained that it was the reservation of the sacred hosts in the chapel that gave her a sense of sacredness (10.31). Many parishioners, however, thought that the space was sacred because the activities in that space only pertain to worship and prayer. As an example, in comparing the chapel with the main worship space, this parishioner indicated that the chapel was sacred because it does not have parties or meetings like the main worship space (7.2).

The relationship of sacredness and spirituality to the physical space was expressed to exist in several other instances. For example, one parishioner described the courtyard as providing a prayerful place to be which leads

to spirituality (15.19). Another parishioner indicated the worship space provides a sense of spirituality because of its openness (4.48).

Not all parishioners saw the building as contributing to an experience of spirituality. In one case, a parishioner described that his sense of sacred can not come from something that strikes him on a daily basis. He said that when he thinks sacred he does not think of the real world (8.42). One parishioner discounted the building as contributing sacredness because the structure has nothing to do with spirituality since it is people and God residing together that gives you sacredness (9.25). For this woman the greatest spiritual experience was receiving communion. which could be accomplished in any building (9.26).

Spirituality was also thought of as a position in the world. One parishioner said, for her, Light of the World is the middle between the world to the east and God in the mountains to the west. Her view was that "we are almost to God but life keeps dragging one back to the world" (6.25). This type of sacredness was not dependent upon the built form but was related to her position within the world.

The liturgist at Light of the World describes reverence as a feeling one has towards God. She indicated that you cannot experience devotion, however, without first having reverence. Reverence is a quality of experiential God-consciousness that leads to a devotional state. In EACW these

qualities of mystery represent one mode of human experience. Further, these experience modes of worship and liturgy are to be more than just exercises of the mind, they are to develop non-rational elements of liturgical celebration, which leads to an experience of wonder, awe, and conversion.

Such experiential modes take on many forms in worship. One parishioner remembers how as a child she was continually reminded that the time after communion was special and she should kneel and thank God to have received the host (9.27). She remembered, though, how hard it was to stay still and to concentrate on just a spiritual thought (9.28). Reverence is not, however, to be a forced posture that has only an outward sign of piety. Rather, it is to immerse oneself without consciousness into the liturgical celebration.

The pastor explained this notion becomes dependent upon the quality of the experiential happenings that are taking place. He said, "music creates reverence, the style of the presider creates reverence, the way the readings are proclaimed, the size and aesthetic qualities of the vessels, the bread and the color of the wine, all create a certain sense of specialness and reverence" (2.25).

At Light of the World attention to small details of this overall aesthetic style does take place. As an example, the slow paced but conscious manner of how the

readers approach the lectern serve to accentuate the specialness of their task. As one parishioner, who serves as a reader, described the importance of when to open the book for reading said, "a lot of people bring up the book (at the entrance processional) and open the book up to their place, I don't do that, I think its an important symbol to open the book right before you start to read" (13.19). Attention to small details such as this, is a critical factor in the development of a specialness and, therefore, a spirituality within the worship space.

While reverence is more of an experience happening through the communal actions of worship and liturgy, devotion is more of an individual experience. As was described in the encounter theme, the combination of group and individual experiences increases a person's contact with their spatial environment. Experience of reverence and devotion form that same link, but for non-rational experiences of wonder, awe, and contemplation, as representative of the mystery theme.

Comparisons

When compared to the ideal theme of "mystery," as interpreted from EACW in chapter three, Light of the World does not completely satisfy people's need for a sense of spirituality. The critical element missing is how people's

past memories of a Catholic Church and sense of mystery, is linked to memories of previous worship experiences. Several parishioners stated how they would have a greater sense of spirituality present if an increase of liturgical art occurred.

EACW states that mystery is a tension between God and our human modes of worship expression. An important issue raised states that it is not God who needs liturgy it is people. The liturgy of the worship celebration is a mode of expression that the Catholic Church does use to create a spiritual consciousness. The existence of a spiritual consciousness is not because God is contained in a worship liturgy of words or images, but the worship liturgy can represent an avenue to feel God's presence.

EACW focuses on the assembly as the most powerful experience of the sacred. It expresses throughout the document, that the action of the faith community gathering together in a worship celebration provides the most important single element for the development of mystery. The manner in which Light of the World celebrates as an assembly supports this key issue.

Almost all the parishioners interviewed felt that their worshipping experiences was now better than at any previously attended church. While not every parishioner identified that their sense of spirituality comes from the assembly, a few parishioners did state that the genuineness

and caring expressions of people in the worship celebration did create special feelings. What I found was a deep involvement by parishioners in their worship celebration, which leads to a caring attention toward other parishioners.

The worship typology at Light of the World is in many ways significantly different than other Catholic Churches. The one-room gathering space archetype present at Light of the World has a worship typology consistent with EACW's simple and less ornate worship spaces. This has produced, however, a worship space considered by some parishioners as too void of liturgical art. Several parishioners stated how they would feel a greater sense of spirituality if more ornamentation and liturgical art was present in the worship space.

At the same time these same parishioners would praise Light of the World's worship space. Two factors exist at Light of the World which reduces this contradiction. First, parishioners described how participation through verbal, visual, and movement actions has created an enjoyable worship environment. Second, attending worship services is no longer an obligation but a pleasure.

This contradiction did identify, however, that while ornamentation provides important experiential qualities, the ability to actively participate in the worship celebration is even more important. An important issue must be raised, though, concerning the amount of liturgical ornamentation

appropriate for a worship space. EACW points out that liturgical ornamentation should not draw a person's focus from the assembly and the worship celebration, yet a person's sense of wonder or contemplation is higher through the use of symbolic liturgical art.

As expressed in EACW, the importance of liturgical art is to serve the action of the liturgy as well as create reflection, wonder, and contemplation. Importantly, this type of experience was expressed by some parishioners concerning the art forms found at Light of the World. The feeling of contemplation and wonder that people expressed when talking about the baptismal font, courtyard cross, tabernacle, and tower is significant and suggests that a sense of spirituality has developed through this type of reflective transcendence.

Unanswered questions exist as to how additional liturgical art might affect parishioners' sense of spirituality or active participation. Also important to understand is whether the movable furniture and altar furniture in Light of the World's worship space is responsible for parishioners' active participation in the worship celebration, or is the social structure of the parish more responsible in creating this significant characteristic. Such issues need to be principle focuses for future research exploration of post-Vatican II worship spaces.

A feeling of incompleteness exists with this chapter.

Basic qualities as to how parishioners experience spirituality and sacredness is presented, but a deeper understanding of how a person's development of spiritual consciousness is still missing. As explained at the beginning of the chapter, two principle reasons are seen to have resulted in this situation.

First, information concerning a parishioners sense of spirituality was difficult to acquire. Future research into spirituality and sacredness will need to develop an interview process that can develop a closer bond between the person and the researcher. Second, EACW as my interpretive source gave little attention to how spirituality and sacredness is experienced. For future research a review of other theological text's will be required to develop a deeper insight into the issue of experiential spirituality.

The previous three chapters have identified the major qualities of Light of the World's worship lifeworld in comparison to the interpreted ideal, EACW. This chapter analyzes how the three themes--environment, encounter, and mystery--exist in combination with each other and then discusses design implications. The first section, "response to EACW," discusses a synthesis of these three themes. Important elements of this combination are the physical and experiential aspects of the worship lifeworld as they determine a sense of place and of community. These issues will be explored in the section "place and community". The last section identifies key design issues that evolved from this research. This section is called "design implications" and establishes a focus for future studies of post-Vatican II worship lifeworlds.

Response to EACW

In chapter three, I stated that each of the themes of environment, encounter, and mystery should be present equally in the ideal worship lifeworld. EACW, in discussing the environment theme, recommends planning a hospitable gathering space in full support of the needs of the assembly. It is important that such a space has an integrity of

materials, furnishings, art, and architecture appropriate for a worship space. Additionally, this space should promote the active participation of each parishioner creating personal and communal experiences of the encounter theme. Further, the action of worship would provide a liturgy in which a person can contemplate the mystery of God's presence.

At Light of the World one important philosophy permeates all three themes and serves to integrate the primary focus of EACW. This concept, which says the church is the people rather than the building, is a critical idea which Light of the World has adapted from the very beginning of its life as a parish. This theology that the church represents the people and that the building is just the house for the people is a philosophical context connecting all three themes at Light of the World.

At Light of the World the environment does provide a place for the assembly to gather. Importantly, as described in chapter five, the architects have used this concept as the major objective in the building's design. The architects' have followed a critical element of the environment theme which says the worship space should not impress or dominate, but should be a space where the assembly can gather. Further, EACW states that a simple less ornate space is appropriate for worship.

Such a space has been created at Light of the World.

It is a worship space that has little visual ornamentation, with well crafted and cleanly detailed liturgical furniture located within a neutral background. It was found, however, that to some parishioners' eyes the worship space is too simple and bare of liturgical ornamentation. The design concept, though, goes back to the primary philosophy that the people are the important element not the space itself. As one parishioner said, the people provide the color and it is the people who are needed to make the worship space become a special place (15.6). Thus, the essential qualities of the environment theme are met at Light of the World through the attention to the primacy of the assembly.

The encounter theme focuses upon the issues of active worship participation within common patterns of sensory and movement experiences. As was identified by parishioners in chapter six, these types of human encounters exist at Light of the World. Importantly, it was found that active participation also developed from the concept that people of the assembly is the most important element of the worship celebration.

An example is how the worship lay ministers are positioned within the assembly instead of located separate from the assembly. This attention to individual actions, affects how communal experience is developed and strengthened in the worship space. Parishioner encounters within the worship space occurred through a variety of sensory

experiences as well as through common patterns of movement, gesture and postures used present within the worship ceremony. This combination of personal and communal experience is a critical focus of EACW and represents an important part of Light of the World's worship lifeworld. Thus, the essential qualities of the encounter theme are present at Light of the World.

The mystery theme relates to people's dependence upon faith, signs, and spiritual beliefs to feel God's presence in the worship lifeworld. EACW states that mystery is a tension between God and our human modes of expression with a primary mode of occurrence through the action of the assembly coming together in worship. As was identified in chapter seven, not every parishioner at Light of the World was able to develop a deep feeling of spiritual consciousness. One example is how, for one parishioner, the downtown Cathedral provided a higher degree of spirituality than does Light of the World. While not every parishioner stated that a deep sense of spirituality existed for them, there was a consistent concept that worshipping as a common assembly was an important element in developing a meaningful worship experience. Thus, the essential qualities of the mystery theme can not be seen to completely exist at Light of the World.

This lack of mystery appeared to represent differences between people's memory of previous worship within highly

ornamental worship spaces and their present experience at Light of the World. In comparison to these remembered experiences Light of the World has few liturgical ornamentation. The result was that some parishioners believe that an increase of liturgical art would be appropriate.

These parishioner's difficulty in acquiring a feeling of spiritual consciousness appeared to stem from an attachment to the more traditional pre-Vatican II worship structures. This response was, however, limited to parishioners over forty years old who's first experiences of worship had been established in pre-Vatican II worship spaces. This does not mean everyone over forty has this view, but it does show how deeply a person's past experience can affect their current experiential feelings. Importantly for future research, those parishioners under forty who primarily have experienced post-Vatican II worship spaces felt very satisfied with the less ornate style at Light of the World.

Physically, Light of the World is a one-room space which follows the domus ecclesiae archetype of meeting house--gathering space. Active participation is promoted through concerns for visibility, audibility, and proximity to the liturgical celebration. The spatial topology of the worship space helps to serve the ability to gather in a participatory fashion. The one physical element that most supports the meeting house archetype and promotes gathering and active participation is the movable seating and altar

furniture.

Experientially, Light of the World displays a unity or wholeness which is described as one critical characteristic in the environment theme. Parishioners stated that the space creates experiential feelings of warmth and comfort which in turn gave the space a feeling of hospitality. The integrity of the building materials and the way they were used is seen as providing a critical element in how parishioners experience the worship space. One example is the glass-block windows which provide a special quality of light when entering the worship space and chapel. The one experiential element that supports EACW is how parishioners support the view that the people are the church. Experientially, parishioners are in many ways immersed in their worship lifeworld.

Place and Community

Parishioners believe that Light of the World is a modern church structure whose design supports the assembly as the primary element of the worship experience. They see Light of the World as a uniquely different Catholic Church, one which has developed a special sense of community. It is a parish community based upon involvement of parishioners in all phases of the parish social structure. While this is primarily a human issue, there exist certain physical

qualities within the building that help support these concepts.

The important single concept of gathering comes from the way the worship space follows the domus ecclesiae archetype of a one-room meeting house. I conclude that the action of gathering would not occur in the same manner if the space had fixed pews and sanctuary furniture. It is this issue of movable chairs and altar furniture which I believe is the single most critical element of the worship environment and supports the development of community ownership. This ability to rearrange the worship space provides one of the critical person-built environment relationships at the parish.

Parishioners through the community experience of rearrangement and some measure of control over the worship space gain a greater sense of involvement. Some parishioners have experienced feelings of warmth and comfort, while other parishioners describe that the space has a home-like feeling. These experiential attachments to the worship space displays an affection to the space which would represent Tuan's (1974a) field-of-care classification.

I will argue that it is the very nature of the physical and experiential elements at Light of the world which promotes a critical aspect, called community ownership. Schlichting (1983) identified that it was a lack of community ownership which created a decline in active participa-

tion in the worship celebration. She defined community ownership as the right of the parishioners to determine the "planning, creation, and decoration of the worship space" (Schlichting, 1983, p.31). It is an idea that the very manner of worshipping already belongs to the assembly.

Other significant person to built environment relationships exist at the foyer, chapel, and tower. The foyer space is the hub of the building which provides a non-worshipping gathering space everyone must move through. To reinforce this quality the architects organized the single main entrance to be on axis with this space. This topological organization offers multiple opportunities for experiential encounters with other parishioners. The opportunity to engage with other people happens, however, not only from the topological organization of the foyer space but also because of the social structure of the parish.

The chapel also promotes its own set of person to built environment relationships. While the worship space and foyer are primarily group experiential spaces, the chapel provides a place for individual meditation and private prayer. The topological organization which supports this experiential quality is the octagonal shape of the space, two story height, and glass-block clerestory windows. This spatial organization establishes a circular enclosure for the space. To visually counter this enclosed feeling the

spatial volume extends upward and pierces the foyer roof where clerestory glass-block windows are located. These windows completely surround the space which causes the natural daylight to cascade into the space from all directions.

The building can also be seen as following Tuan's (1974a) image of a public symbol. The building with its distinctive tower, which has a conical stainless steel skylight, is the primary exterior physical element that draws one's attention. The status as a public symbol is further enhanced through the building's placement in the landscape and visibility to people. It receives much of its attention through this visible image.

The tower serves as a good example of a significant person and built environment relationship. At issue is a question of conscious vs. unconscious symbolism and how appropriate this difference is in creating people's sense of place and community. The building's high level of articulated geometry and formal structure is culminated by the tower. The liturgical artist stated that, "the tower is the dynamic focal point of the building's exterior and the place where many diverse elements are combined" (Buscemi, 1987, p.2). It is the tower which also provides a public symbol while retaining a formal worship typology to denote a worship structure.

The issue of conscious to unconscious symbolism is a

concern for how parishioners experience the environment, encounter, and mystery themes of their worship lifeworld. For example, the tower is designed with a liturgical symbolism not completely understood by most parishioners. The liturgical artist explained that the tower is an "apt parallel to the importance of baptism and the life of a Christian community" which happens through the tower's position above the baptismal font (Buscemi, 1987, p.2).

Such transference from structural form to experiential mystery are not easily understood by parishioners. There becomes a point, however, when the need to create wonder and contemplation rests in the development of such high levels of symbolic meaning. It is the development of such an architectural form that evokes an aspect of contemplation even though parishioners have a less than obvious understanding of the symbolic meaning. The tower's design, therefore, is important because people are aware of the tower's presence and they understand that a special symbolic meaning has been created by its design.

The tower's image in relation to the rest of the building also serves as a good example to the parish's identity as a community. Like the design of the tower, as a community they see themselves exploring the very contemporary issues of worship that have developed out of Vatican II. They are forward in their outward image to the city with the conical stainless steel tower, which is void of a

cross, yet they have retained the essential typological element of the vertical dimension which the tower offers. The same is true for the worship space, which is advanced in its design, because of its one-room worship space with movable furniture, yet the parish consciously wants to retain the historic liturgical rituals of the Catholic Church.

A good analogy to represent Light of the World's community is that they respond like an adolescent moving into adulthood. They see themselves as a young adult needing to test their new beliefs concerning worship and community, yet they can not break away too far from the safe traditional ideas of the Catholic Church. Their building provides the progressive image of a different worship community which is based upon broad participation of parishioners as community leaders, rather than the typical pattern of just a few people providing the leadership.

This important quality of the immersion of people in parish leadership activities is a critical factor in the development of Light of the World's community. From volunteering secretarial support at the parish office to the year long involvement of some parishioners in the development of the parish's annual three-day fair, people are totally involved in every facet of the parish.

Parishioners as well gather in more than worship and prayer, they come together for meetings, presentations,

dances, dinners, pancake feeds, picnics, and many other activities. The building is used almost every day and there are frequently several activities occurring in the same day. The church becomes a meeting place for the parish as well as the community. Parishioners fully develop their sense of community through the social structure of the parish which focuses less on popularity and more on service to the parish community. This parish's organization serves to involve many people in the parish government.

Briefly, there exists not an elected parish council, like in most Catholic parish's, but a group of parishioners who are selected through a discernment process of individual assessment. This group of parishioners then serves with a coordinating council and provide the leadership for the parish's five separate ministries. These five ministries-- Christian outreach, religious formation, administrative support, youth, and liturgical--have a combined total of sixty-two different meeting groups.

What this means is an involvement by not just a few parishioners, but the involvement of many parishioners, at all age levels, in the development of programs and services for the parish community. This level of involvement produces a commitment of service which induces other parishioners to also become involved in parish activities. As one parishioner remarked, he has never been as involved with any other parish, but at this parish, you just can't

resist (8.22).

The foregoing commentary has produced, maybe, to glowing a picture of the parish. A weakness in my research approach is the likelihood that parishioners not interviewed have had completely different experiences than what has been presented in this thesis. The general picture of this parish's community structure is, however, accurate and does indicate a progressive parish which would involve many people. Additionally, a factor not covered, since they were just being established, is how smaller neighborhood community groups can, in the future of the parish, produce more opportunities for community development.

Design Implications

Like the adolescent analogy of the parish community the building's design creates an adolescent image of a traditional architectural form that represents a breaking away into adulthood. The design is both traditional and at the same time overtly contemporary. The worship space can best be described as having evolved from the ancient basilica typology of a central space flanked with side aisles. At Light of the World, this spatial pattern has been transformed into a one-room worship typology of gathering space. This combination provides the most important design implication to be found in the building.

Light of the World breaks away from the more common approaches for designing a worship space in three significant ways. First, the building has been designed to function not just as a worship space. The ability to conduct different activities, such as meetings, dances and dinners is a physical quality that supports community development. Second, in response to the ability to handle this variety of activities, the worship space was designed without fixed pews or altar furniture. This critical decision is the single most important physical characteristic that has enhanced the sense of community ownership and gathering. I conclude that if everything else is equal except for fixed or movable furniture, the experiential qualities of parishioners encounters would be greater with the movable furniture. Third, instead of a worship space which has a dark interior as provided from stained glass and dark wall surfaces, the interior has a high brightness level that enhances the visibility and openness of the worship space.

The building has an architectural quality and appropriateness in retaining the traditional morphology of the basilica while producing a contemporary building typology. My research indicates that the development of this new building typology, based upon the archetype of gathering space, would not be as experientially significant without the use of movable seating and altar furniture. For

parishioners, the most important single element of the worship space is the baptismal font and its tower structure. It is interestingly that the symbolic vertical dimension, afforded by the tower over the font, provides one of the strongest attachments to the building.

To have trustworthiness and validity with this assumption would require an extension of the research conducted at Light of the World. A phenomenological research study that would focus upon comparing the physical and experiential qualities of two churches would be one requirement. This comparison would examine one worship space with fixed furniture and one worship space with movable furniture. The important single quality within both worship spaces would be that they both follow the one-room gathering space archetype.

My research has shown that this particular building has a high public image yet at the same time creates a field-of-care for parishioners. Attention is drawn to the building because of its unique exterior tower design as well as the geometric brick pattern. Through this combination the exterior image can be seen to represent both a traditional and contemporary worship typology. It was found that the worship space supports active participation as well as community ownership. The single critical element of the worship space appears to be the movable seating and altar furniture.

In summary, the following design implications are found to be important for future Catholic worship spaces.

- * The domus ecclesiae archetype of a one-room gathering space should be adapted into the design of Catholic Churches.
- * The use of movable seating and altar furniture within the worship space is recommended, as it enhances active participation and communal experiences by the assembly.
- * It is recommended that buildings incorporate non-worshipping gathering spaces into their designs to help support the development of parish community.
- * To promote community ownership, more opportunities concerning the liturgical planning, development, and installation of worship decoration and furniture arrangements of the worship space should reside in the parish.
- * Contemporary modes of liturgical art and ornamentation must continue to be incorporated into the worship space to strengthen people's sense of spiritual consciousness.

BIBLIOGRAPHY

Allen, Horace T. "Watchers of Holy Ones: Spectators or Sancti." Liturgy 23, no. 5, (1978): 10-15.

Beard, Bill. "Seating for Catholic Worship: A Primer." Environment and Art Letter 1, no. 1. Chicago Liturgical Training Publications (1988): 2-3.

Bishops Committee on Liturgy. Environment and Art in Catholic Worship. Washington, D.C.: United States Catholic Conference, 1978.

Bloomer, Kent C. and Moore, Charles W. Body, Memory and Architecture. New Haven, Conn: Yale University Press, 1977.

Bourgeault, Cynthia. "The Church and the Arts." Liturgy, 23, no.5 (1978): 5-9.

Bouyer, Louis. Liturgy and Architecture. Notre Dame: University of Notre Dame Press, 1967.

Brill, Michael. "The Mythic Consciousness as the Eternal Mother of Place-Making." Paper read at Built Form and Cultural Research Conference, University of Kansas, November, 1986.

Buscemi, John. "Light in the World Catholic Church," Denver, Colorado: Hoover Berg Desmond, 1987.

Caemmerer, Richard R. Visual Art in the Life of the Church. Minneapolis: Augsburg, 1980.

Ciferni, Andrew D. "A Room for the Assembly." Liturgy 80 18, no. 4, (1987): 6-9.

Clark, Roger H. & Pause, Michael. Precendents in Architecture. New York: Von Nostrand, 1985.

Collins, Patrick W. "Liturgical Renewal, twenty years later" Commonweal CXI, no. 11, (1984): 330-334.

Conklin, William J. "People and Stones." In The Environment for Worship. Ed. The Bishop's Committee on the Liturgy and the Center for Pastoral Liturgy, Catholic University. Washington D.C.: United States Catholic Conference, 1980.

Culver, Virginia. "Church's modern design connects to past." The Denver Post, 27 June, 1987.

- Debuyst, Frederic. Modern Architecture and Christian Celebration. Richmond, VA: John Knox Press, 1968.
- Diekmann, Godfrey, O.S.B. "The Eucharist Builds Up the Building." In The Environment For Worship Ed. The Bishop's Committee on the Liturgy and the Center for Pastoral Liturgy, Catholic University. Washington D.C.: United States Catholic Conference, 1980.
- Dixon, John M. "Community Beacon: Light of the World Catholic Church" Progressive Architecture, February 1986, pp 27-35.
- Dovey, Kimberly. "The Ecology of Place and Placemaking." In Place and Place-Making. Ed. K. Dovey, P. Downton, and G. Missingham. Melbourne: Faculty of Architecture and Building, Royal Melbourne Institute of Technology, 1985a.
- _____. "The quest for authenticity and the replication of environmental meaning." In Dwelling, Place and Environment, Ed. D. Seamon and R. Mugerauer. Boston: Martinus Nijhoff, 1985b.
- Eliade, Mircea. The Sacred and the Profane. New York: Harcourt Brace Jovanovich, 1959.
- Engel, Ronald. "The question of the place on which we stand: An agenda for religious social ethics." In Liberation and Ethics, Ed. C. Amjad-Ali and W.A. Pitcher. Chicago: Center for Scientific Study of Religion, 1985.
- Ensman, Richard G. "Community Space in Churches." Modern Liturgy 11, no. 2 (1984): 31-32.
- Ferguson, George. Signs & Symbols in Christian Art. New York: Oxford University Press, 1954.
- Filthaut, Theodor. Church Architecture and Liturgical Reform. Baltimore, Maryland: Helicon Press, 1968.
- Fitzer, Joseph. "Liturgy as Visual Experience." Worship 48, no. 4, (1974): 217-229.
- Fleming, Austin H. "A Spirituality for the Assembly at Worship." New Catholic World 230, no. 1376 (1987): 61-64.
- Freberger, William J. "Liturgy: The Next 20 Years" THE PRIEST 40, no. 4, (1984): 14-20.
- Gough, Michael. The Early Christians. New York: Frederick A. Praeger, 1961.

- Graber, Linda H. Wilderness as Sacred Space. Washington, D.C.: The Association of American Geographers, 1976.
- Gy, Pierre-Marie, O.P. "Space and Celebration as a Theological Question." In The Environment for Worship. Ed. The Bishops' Committee on the Liturgy and the Center for Pastoral Liturgy, Catholic University, Washington D.C.: United States Catholic Conference, 1980.
- Guzie, Tad. The Book of Sacramental Basics. Ramsey, N.Y.: Paulist Press, 1981.
- Harries, Karsten. "Thoughts on a Non-Arbitrary Architecture." Perspecta. 20, (1983): 9-20.
- Hellwig, Monika. The Meaning of the Sacraments. Dayton, Ohio: Pflaum Standard, 1972.
- Hillard, Dick. "Assembling the House for Worship." Modern Liturgy 7, no. 8, (1980): 6.
- Hoover Berg Desmond. "Architectural Program: Light of the World Catholic Church." Denver, Colorado, 1981.
- Hovda, Robert W. "It begins with the assembly." In The Environment for Worship. Ed. The Bishops' Committee on the Liturgy and the Center for Pastoral Liturgy, Catholic University. Washington D.C.: United States Catholic Conference, 1980.
- Jacobs, Jane. The Death and Life of Great American Cities. New York: Random House, 1969.
- Johnson, F. Ernest. ed. Religious Symbolism New York: Harper & Brothers, 1955.
- Jouneil, Pierre. "Places of Christian Assembly: The First Millennium." In The Environment for Worship. Ed. The Bishops' Committee on the Liturgy and the Center for Pastoral Liturgy, Catholic University. Washington D.C.: United States Catholic Conference, 1980.
- . "Art and Liturgy." In The Environment for Worship. Ed. The Bishops' Committee on the Liturgy and the Center for Pastoral Liturgy, Catholic University. Washington D.C.: United States Catholic Conference, 1980.
- Kennedy, Eugene. Re-Imagining American Catholicism. New York:Vintage, 1985.

Lawlor, R. "Geometry at the Service of Prayer: Reflections on Cistercian mystic architecture." Parabola 3, (1978): 12-19.

Lee, Bernard J., S.M. ed. Alternative Futures for Worship Vol. 3 The Eucharist. Collegeville, Minnesota: The Liturgical Press. 1987.

Low, Setha M. "Developments in Research Design, Data Collection and Analysis: Qualitative Methods." In Advances in Environment, Behavior and Design Ed. G.T. Moore and E. Zube. New York: Plenum, 1987.

Malarcher, Willy. "Process toward design." Liturgy 23, no. 5, (1978): 30-31.

Mauk, Marchita B. "The Environment for Worship." New Catholic World 230, no. 1376, (1987): 84-87.

McManus, Frederick R. "Recent Documents on Church Architecture." In Church Architecture The Shape of Reform. Washington, D.C.: The Liturgical Conference, 1965.

Mossi, John P. "The Liturgical Environment" Folk Mass and Modern Liturgy 1, no. 2, (1974): 10-13.

Norberg-Schultz, Christian. Genuis Loci: Towards a Phenomenology of Architecture. New York: Rizzoli, 1980.

_____. The Concept of Dwelling. New York: Rizzoli, 1985.

Notebaart, James. "How to Make the Space for Liturgy Special." Folk Mass and Modern Liturgy 1, no. 3, (1984): 9-12.

Osborne, Kenan. "Eucharist Theology Today." In Alternative Futures for Worship. Vol.3, The Eucharist Ed. Bernard J. Lee. Collegeville, Minnesota: The Liturgical Press, 1987.

PA Design Award, "Light of the World Catholic Church." Progressive Architecture, January 1984.

Palmer, Parker J. The Company of Strangers. New York, Crossroad, 1986.

Relph, Edward. Place and Placelessness. London: Pion Limited, 1976.

Richstatter, Thomas, O.F.M. "Alternative Futures for the Eucharist." In Alternative Futures for Worship, Vol 3. The Eucharist Ed. Bernard J. Lee. Collegeville, MN: The Liturgical Press, 1987.

Rowles, Graham D. "Reflections on Experiential Field Work." In Humanistic Geography: Prospects and Problems. Ed. David Ley and Marwyn Samuels. Chicago: Maaroufa Press, 1978.

Schilichting, Janet. "Holy People Make Holy Places." Liturgy 3, no. 4, (1983): 29-35.

Seamon, David. "Phenomenology and Environment--Behavior Research." In Advances in Environment, Behavior and Design Ed. G.T. Moore and E. Zube. New York: Plenum, 1987.

_____. "Body-Subject, Time-Space Routines and Place Ballets." In The Human Experience of Space and Place, London: Croom Helm, 1980.

Seamon, David and Nordin, Christian. "Marketplace as Place Ballet." Landscape 24, (Oct. 1980): 35 - 41.

Seamon, David and Robert Mugerauer. Eds. Dwelling Place and Environment, Boston: Martinus Nijhoff, 1985.

Searle, Mark. Liturgy Made Simple. Collegeville, MN: The Liturgical Press, 1981.

Seibold, Llewellyn. personal communication, 1985.

Sheehan, Thomas. The First Coming. New York: Random House, 1986.

Simcoe, Mary Ann. Ed. The Liturgy Documents. Chicago: Liturgy Training Publications, 1985.

Simons, Thomas G. and James M. Fitzpatrick The Ministry of Liturgical Environment. Collegeville, MN: The Liturgical Press, 1984.

Sovik, E. A. Architecture for Worship. Minneapolis, MN: Augsburg, 1973.

Sullivan, Daniel J. "Symbolism in Catholic Worship." In Religious Symbolism. Ed. F. Ernst Johnson. Bingham, N.Y.: Vail-Ballou Press, 1954.

Tuan, Yi Fu. "Moral Ediface & Architectural Ediface." Paper read at Built Form and Cultural Research Conference, University of Kansas, November 1986.

Tuan, Yi-Fu. "Space and Place: Humanistic Perspective." In Progress Human Geography. London:Edward Arnold, 1974a.

_____. Topophilia. Englewood Cliffs, N.J.: Prentice Hall, 1974b.

Turner, Harold W. From Temple to Meeting House. New York: Mouton, 1979.

Violich, Francis. "Toward revealing the sense of place: An intuitive 'reading' of four Dalmatian towns." In Dwelling, Place and Environment, Eds. D. Seamon and R. Mugerauer. Boston: Martnus Nijhoff, 1985.

Weakland, Rembert G. "Art and the Church: The need for mainstreaming." In The Environment for Worship, Ed. The Bishops' Committee on the Liturgy and the Center for Pastoral Liturgy, Catholic University. Washington D.C.: United States Catholic Conference, 1980.

Weil, Louis. "Shaping the Environment of Initiation." In The Environment for Worship. Ed. The Bishops' Committee on the Liturgy and the Center for Pastoral Liturgy, Catholic University Washington D.C.: United States Catholic Conference, 1980.

Westerhoff, John H. III. "Celebrating and Living The Eucharist: A Cultural Analysis." In Alternative Futures for Worship, Vol 3. The Eucharist. Ed.. Bernard J. Lee. Colledgeville, MN: The Liturgical Press, 1987.

White, James. "Liturgy and the Language of Space." Worship 52, no. 1,(1978): 57-66.

White, James F. Protestant Worship and Church Architecture. New York: Oxford University Press, 1964.

Whyte, William H. The Social Life of Small Urban Spaces. Washington D.C.: The Conservation Foundation, 1980.

Yudell, Robert J. "Body Movement." In Body, Memory and Architecture. Ed. Kent C. Bloomer and Charles W. Moore. New Haven: Yale University Press, 1977.

APPENDIX A

This appendix contains selected sections of recorded interviews with the architects', pastor, associate pastor, and parishioners. These interviews represent one part of the research study occurring at Light of the World Catholic Church, Littleton, Colorado, during June and July of 1987. Each interview has been coded with a number for use in citing of references in main text. To retain confidentiality of each parishioner, all references made to a particular church, place, or person has been left blank. Where appropriate, any added text that gives clarification as to meaning or description has been placed as a parenthetical word. As a general rule, each interview has been divided into the thesis's three main themes of environment, encounter, and mystery.

Interview with Architects', Code 1.00

Environment

- 1.1 The core group of people, Hoover Desmond Berg, Fr. Syrianey, Rev. Eugene Walsh, Rev. John Buscemi, along with the members of the parish (building committee) started off right at the beginning with EACW as one of the key elements.
- 1.2 I think we actually came together as a team right at the very beginning. Right as soon as I was hired I had a meeting with Gene and John (liturgical consultant and artist). We really started the whole process together.
- 1.3 During the programming phase of the project, basically, it was Fr. Syrianey, Gene Walsh, John Buscemi and myself. As I recall, we had some meetings with some members of the building committee from time to time, and we talked to them when it came to purely quantitative aspects of the program. In terms of liturgical theological things it was pretty much left up to the four of us.
- 1.5 But of course not everyone liked what was happening. There were people who don't go there today because they don't think its a church.
- 1.6 Fr. Syrianey was responsible for putting together the design team.
- 1.7 We were very concerned about what you typically see in the Catholic Church. Well in every church. You see a lack of organization, a lack perhaps of a master plan. The gallery provided a very strong coordinating element. Its linear design allows them to plug in. They can just keep going to the east. Classrooms, multipurpose rooms, offices, they can do whatever they want to happen in a very organized fashion.

- 1.8 We looked more at the primacy of the assembly as being really important thing, the group assembled.
- 1.9 EACW was quoted quite extensively in the program.
- 1.10 We wanted to maintain a modest scale even though we were doing the building at the highest portion of the site.
- 1.11 (EACW) was looked upon as a body of program information, just as you would look upon any other program information provided by the client.
- 1.12 The parish felt the building should be placed at the highest part of the site, yet at the same time not make the wrong statement by being dominant (to the neighborhood). So we wanted to maintain a modest scale even though we were doing the building at the highest point.
- 1.13 I think the reason why the (building) has received so much attention is that it is a real departure from what had been done recently in Roman Catholic Worship space design.
- 1.14 We were originally designing the building to seat 500 for worship, and the archdioceses said you will design your building for 1200-1300. I'm not sure what happened but somehow they changed (and said) Fr. Syrianey could design the church for 500 with an expansion to 800. Their whole idea and they still feel you can't have good liturgy with that many people.
- 1.15 We felt it was very important to provide a rather substantial space for gathering prior to Mass. Also as a gather space after, that was from day one we would want a very large gathering space. The foyer space was also a very important element.
- 1.16 During the programming phase we were going through a lot of various seating arrangements and of course looked at a lot of different forms, more contemporary at first, but the forms seemed always to get better. The flexibility in the seating is the key and appeared to represent what the proper response is for worship.
- 1.17 I don't think anybody on the design team feels as though LOW is the final and best response. I think we all look at it as a transitional piece. As John Buscemi says, this is something that had to be done.
- 1.18 He (Buscemi) was very active during the course of the design, he really became a sounding board in terms of what we were doing architecturally and particularly when it came to the design of the tower.
- 1.19 (The landscaped area in front of the building) we felt from an architectural standpoint really enhanced the building by maintaining a reasonable foreground.
- 1.20 The whole idea is very linear in concept. We got Bowles Ave., then a buffer, the building which will someday extend linearly, another landscaped area, which is very linear in fashion, then we have the parking.

- 1.21 There was a real concern about what Bowles Ave. to become a distraction to the process of coming together as a church community and the whole gathering process which starts in the parking lot. That caused us to turn the entrance to the south.
- 1.22 The whole idea was that we would minimize the impact of the automobile on the site and we would especially maintain, the long range views to the south (mountains).
- 1.23 The parking lot is always a real problem and we had a really good opportunity to really conceal much of the parking from Bowles Ave. We did not want to be looking across a sea of cars.
- 1.24 The (building) elements needed to have a pretty modest scale. The tower is not a real dominant element when you compare it in terms of what one historically thinks of tower. And the 8' module helps to give it scale.
- 1.25 I guess in looking at the variety of spaces that we had, the (human) scale we were trying to achieve, the eight foot module seemed to be appropriate. I suppose we could have chosen something else.
- 1.26 Baptismal font did move after the schematic design phase.
- 1.27 The Light Monitor was the reconciled part of the square/circle.
- 1.28 (The light monitor at tower) When you take the circle and square their intersection becomes the place where the two opposite (forms) are reconciled. It seemed very logical in the way we did it.
- 1.29 The tower was one of the most difficult and time consuming design efforts we have ever gone through. I don't know how many times we thought we had it and would sit back, look at it and it just wasn't adequate.
- 1.30 While design is based on an 8' grid it was not based on any predetermined idea except maybe a concern for human scale.
- 1.31 (The shift in brick color) that's the reconciled opposites and that's real important. In the fundamental geometry its very basic early Basilican (style) of architecture.
- 1.32 Hoover Berg Desmond provided design work in collaboration with Fr. Buscemi for furniture, platforms, baptismal font. Fr. Buscemi is completely responsible for cross design (and he) designed the mobile above the font.
- 1.33 (In LOW) you really don't see really expensive materials. Its all pretty basic materials. How we detailed helps to give it a quality. The brickwork, trusses, lighting.
- 1.34 The lighting is one of the special qualities (designed into LOW).

- 1.35 It was either Buscemi or Walsh who said that the Chapel is a large tabernacle. You have the smaller tabernacle that the sacred hosts are in and the larger tabernacle, as the space where the people are in.
- 1.36 Maybe its more because the furnishing and devotional items and things in that room that disappoint and (make the space) not quite like it should. The space is a little cluttered and they really don't have a handle on how not to have the space look fractured. It was designed to sit 25 or something like that.
- 1.37 I think the octagonal (form) is a very old Christian form. I suppose it could have been another shape.

Encounter

- 1.38 Gene Walsh said the gathering process starts when you get up in the morning, and you put on your Sunday clothes and you start down the street and someone else is coming and ultimately you end up in the parking lot, starting to gather and coming into the gathering space.

Mystery

- 1.39 It seemed that (EACW) was saying to us that we (should) really be getting back to some fundamental early Christian manifestations of (church).
- 1.40 Fr. Syriane really saw this (programming phase) as an educational tool for the Parish and to try to bring them up to a common understanding of what importance liturgy had in their lives.
- 1.41 We looked at the primacy of the assembly as being really important, so the building became supportive to the individual's personal spiritual life.
- 1.42 Their whole idea, and they (liturgical consultant and Fr. Syriane still feel you can't have a good liturgy with that many (1200 - 1300) people. (LOW) has 500 - 600 with expansion to 800 - 900.
- 1.43 I think there is a problem with a lot of liturgical architecture because in many cases very subjective responses based upon the architect's personal theology or lack thereof. I don't think that's a true reflection, true response, to the Roman Catholic liturgy as (it is) suppose to be in this time and place.

Pastor's Interview, Code 2.00

Environment

- 2.1 Right now, without (landscaping) the north wall is uninviting. But it (LOW) has a stately looking angularity. I do not see the church as setting its back to the town. But its different and I like that. My first impression (however) was that they make concrete blocks inside this building.

- 2.1 (The north wall) needs time and money to get trees planted. The idea is to have trees along the sidewalk and shrubs along the wall.
- 2.3 Once you come around to the front you forget the street side, but that does not help those people who just drive by.
- 2.4 (The tower) people look at it and are perplexed (as to what in the world it is and, perhaps, don't know what to ask about it. The circle/square does not come through for the average person.
- 2.5 (What makes LOW unique) its radically different than any other place (of worship) I have been before. I think part of it has to be the spirit of Fr. Syrianev because it is radically different. He had to step out and do something different. He really believed that church was people and called for people to make the community to happen. He preached that, talked that, and acted that, and he was trusting.
- 2.6 LOW was (designed as) a blend of wanting a multi-purpose space that was also to be something special, which happened through the design of baptismal space.
- 2.7 The baptismal font really does work OK at the entrance.
- 2.8 The foyer and courtyard seem to be (the places) or parts of the church that people seem to like the best. (The foyer is) a place for conversation. (The courtyard) is nice and outdoors.
- 2.9 I like the courtyard a lot but it does take people to make it come alive.
- 2.10 The eucharistic chapel does not seem to be designed for daily service, it is too small.
- 2.11 (Some problems at LOW); No storage in building; A naive sense of not thinking LOW would need a cry room; No awareness for the needs of day care; No sense of (How to accommodate) education.
- 2.12 I am embarrassed by the reconciliation chapel. Where was the sacramental theology when they designed this space? It shows it was on the main worship space.
- 2.13 The better post-Vatican II concepts were to bring the altar closer to the people, a reduction in the size of the altar, a semi-circular arrangement with the focus being the altar.

Encounter

- 2.14 LOW is a building that works well with people in it, it is too cold, repetitious without (people).
- 2.15 The part I like best is the worship space on Sundays, its openness and directness with one another (gives) a sense of congregational gathering. Particularly (because) the fact it has chairs.
- 2.16 LOW is a friendly place. It correlates with youth, being young or youthfulness.

- 2.17 The whole building is open, noise is a problem. Both visual and sound problems in openness for private prayer.
- 2.18 (The need for) private prayer is a key issue. An awareness that people need silence. (LOW) needed to be designed for that.
- 2.19 Church needs to be designed where people can share silence.
- 2.20 The softness of a room (such as the worship space and chapel) comes from light.
- 2.21 The great opportunity when you build a church is to educate people (about liturgy).

Mystery

- 2.22 Prior to Vatican II sacred space was seen as private space and was divided between really sacred space on the other side of the communion rail (sanctuary) and the attached space for the laity (people) to observe the Mass.
- 2.23 Today the people at LOW would see sacred space as being wherever the people were gathered doing ritual things that are designed to help them be in touch with God.
- 2.24 Liturgy is so structured it requires a correctly designed space if its going to be done well.
- 2.25 The notion of reverence is very important. Music creates reverence. The style of the presider creates reverence. The way the readings are proclaimed. The size and aesthetic quality of the vessels. Even the bread and the color of the wine creates a certain sense of specialness/reverence.
- 2.26 In the liturgy and assembly reverence is maintained by discipline of the group and the leaders.
- 2.27 This parish expects the Vatican II style (of liturgy), they have an awareness.
- 2.28 A major element at LOW is the baptismal font, it is something special and was from the beginning seen as being important in terms of a sacrament.
- 2.29 The difficulty in this building is there is no place for private experience. The eucharistic chapel is out in the open.
- 2.30 For private experience, in that situation, orientation and ornamentation is more important.
- 2.31 I find it difficult to achieve a personal sacred experience at LOW. I have tried to walk the hall (gallery) but everything is so beautiful outside and therefore distracting.
- 2.32 Warm and sparseness is what I need to help feel a sense of sacredness.

Associate Pastor Interview, Code 3.00
Environment

- 3.1 The church where I just came from (french church), the seating (number of people) is about the same as LOW but the last person in the last pew sits a lot farther (away) than the last person sits in the worship space here.
- 3.2 Even though the (french) church was so hugh you never felt far away, people were really a family.
- 3.3 The biggest problem with that (french) church was the sound system, it (space) was so hugh that everything echoed. (It was) good for music but not for speaking.
- 3.4 The one thing about LOW is that here there is space, openness and room to be creative. The openness is important because it is there for the potential of use.
- 3.5 (At LOW) I guess probably that part of the building which struck me the most was the baptismal font. In the pictures (sent before arriving at LOW) the baptismal font looked hugh, it looked like a big stately Cathedral that you enter through marble columns not steel (as it really is). The stone (for baptismal font) looked magnificent, sturdy, and powerful.

Encounter

- 3.6 Here at LOW I would prefer (for the homily) to be at the front of the altar instead of at the side like I have been doing. I guess I have not really felt comfortable at doing that (because) I feel there needs to be more space in back of me.
- 3.7 Part of my reason for not staying behind the ambo (lectern) is because I want to be vulnerable, I want to be at risk.
- 3.8 The big difference with the music here, the people, I think, are more encouraged to sing. Where in a big church which has a strong choir, people are more inclined to listen.
- 3.9 (Vatican II readings talk about developing a caring community) which we have done in many churches. I also think it is important now (to go) beyond that good feeling of people gathering together.
- 3.10 (Christian Life Communities) are professional lay people who wanted more out of their parish (and) who gathered in small community (groups) with the hope of affecting the parish.
- 3.11 The purpose of the (small) communities is to gather people together and help them reach a point where they can see they can be a community and have a faith and be church without necessarily needing a priest, a deacon or a minister. That these communities would sustain themselves because of the very reason they were gathering together as faith scripture of the Lord Jesus and the church. To strengthen themselves without

- depending on an ordained minister.
- 3.12 (Basic philosophy of community groups) 1. Faith sharing, 2. Social, 3. Learning and becoming more aware about the church, 4. Out of the community would evolve some sort of social outreach.
- 3.13 We are looking for 14 - 16 people. I think that's big but if several people don't come you will not feel the void and the community can continue to move forward.
- 3.14 These small communities can add substance and deeper root to the original.
- 3.15 In a sense it would be a maturing process. There is a recognition as to what the church is to that group. For sure that would affect the parish, changing the spirit (from a spectator type of experience to a participant type of experience).
- 3.16 I have (though) seen people who belong to a community group out of revolt to what they have seen and because of what wasn't there (at the service). They have separated themselves from the church (instead of trying to affect the liturgy for the best interest of the parish, through the church).

Parishioner Interview, Code 4.00
Environment

- 4.1 (Most remembered church) was in an older church, turn of the century style, high ceilings, statues, very large church, typical Sunday was restricted, crowded, hot, had giant steps, lots of entrance steps, but very little platform to stand at top of steps, vestibule was too small, main aisle and side aisles, communion rail.
- 4.2 (Least liked church) was too sterile, the architecture was very plain, very square. Closeness but not intimacy. Ceiling was white acoustical tile (a flat ceiling).
- 4.3 (Least liked church) was a long space with parallel seating, lectern on one side, Cantor on other, had communion rail, built in the early 60s, flat, acoustical tile ceiling, architecture was plain, square space, had pews, preferred temporary space with folding chairs. I preferred the temporary space with (its) folding chairs over the finished designed church.
- 4.4 (At LOW) the building says to the city that we are different, and that's OK.
- 4.5 I have had people reflect back to me, oh, near Kipling and Bowles, is that really a church?
- 4.6 Chairs facing each other is a terrific preparation for Lenten Experience. Let us confront who we are.
- 4.7 Initially I was very uncomfortable with (face to face) seating.
- 4.8 (Altar) Is a dinner table, a place to come to eat.

- 4.9 (Lectern) I do not think it belongs there, never had. Seems to separate the person from me. Would be better with just a microphone.
- 4.10 Not having stained glass has removed (bad) feelings about Pre-Vatican II churches. Absence helps to block out. I don't miss the stained glass.
- 4.11 After LOW I have gone to churches with pews and I feel confined and separated.
- 4.12 (Without pews) people are more relaxed.
- 4.13 The foyer, courtyard and gallery areas all help to develop community. (As an example) the gallery gives a place for kids to run. The foyer is used for everything from dances, dinners, meetings--same for the courtyard. The courtyard means to me unity, togetherness, getting together with other parishioners being with everybody else, which means being a part of the church, a part of God. It gives us the ability to share with each other.
- 4.14 Would like to go into the courtyard but because the doors are not open that does not happen.
- 4.15 (Chapel) I like the closeness of it. It forces you to be close, yet at the same time it has a spaciousness.

Encounter

- 4.16 Getting to LOW parking area is frustrating, but that is not the reason I arrive early, I start visiting with people from the time I step out of the car.
- 4.17 Upon arrival I take in the landscaping and consciously look at the spiral (tower).
- 4.18 Generally I enter through the main doors when coming to LOW. It is my preference.
- 4.19 Reason to get to church (early) is not because you want a place to sit but is the action of the people you are going to meet and talk to.
- 4.20 I attend the middle Sunday Mass because I can talk to people leaving the first Mass and stay to visit with those people coming to last (third) Mass.
- 4.21 Hospitality is what we do in our homes, work, everywhere, we are hospitable people, and we give each other space and choice. The old term, usher, leads me to think of a funeral and that people need assistance getting in and out.
- 4.22 Everywhere there is a gathering of families. The children play at the foot of the courtyard cross. That is very much a part of who we are (at LOW).
- 4.23 We need each other in community in order to be able to truly love and believe in Christ and God. Without identifying ourselves with a community there is no way his message can be conveyed to the rest of the world.
- 4.24 I notice how the number of people in conversation before Mass is increasing each week and I love that. I don't think pews would have allowed that to happen.

- 4.25 The theology of being a Christian is to come together in community.
- 4.26 The mini courtyard at the main entrance has seating which invites people to stay. Kids play on the front lawn.
- 4.27 Visual preparation is to make eye contact with the eucharistic (cannon) as it is happening.
- 4.28 The light drawing people into the church area comes from the Baptismal Font tower.
- 4.29 Being able to hear sound--music, readers, minister--it does not matter which part of the worship space you sit in.
- 4.30 The music is very well coordinated and it enhances the service.
- 4.31 Along with pews come missalettes and with missalettes come separateness and no one is visually participating in the eucharist. They are too busy with their missalettes.
- 4.32 Having and using kneelers is a false reverence because if you are separated, as what happens with using pews, you are not connecting in any way, visually or physically. To me it is closing instead of opening up.
- 4.33 Light experience, especially at Easter time. Many, many times light comes in windows and has enhanced liturgical experience at the most appropriate time, saying God is here.
- 4.34 The cross in the courtyard was to be at a level where we all can experience it each day, not out there on top of the building or far away, but right there where we can touch it as part of that experience.
- 4.35 Even when the Chapel is not full, people will take folding chairs and sit in the doorway. They come late and leave without conversing. Its almost like they have a need to be there but not a need to be a part of the community. It is always the same people.
- 4.36 My (least liked church) had closeness but not intimacy.

Mystery

- 4.37 Catholic teaching tells us that we are to know God, it does not (say) I am to be known by God or that God needs to know me.
- 4.38 (A previous worship space with a high sense of sacredness) was a chapel conducive to intimacy. Gathering space outside chapel was large. Space to talk and meet people. Did not enter chapel directly from outside, had to pass through gathering space. Space was actively used other than for worship.
- 4.39 (At LOW) sacredness starts to exist outside of the church before I enter.
- 4.40 Spirituality increases because of the community action.
- 4.41 I feel that the movement of the spirit is so much more powerful throughout the community because there is eye

- contact with face-to-face seating.
- 4.42 (Spirituality means to me) experiencing that I am known by God.
- 4.43 As individuals we drift in too many different directions but the power of that community (with) the belief in the faith and knowledge of God and really knowing, feeling and understanding the Love of Christ. We are empowered to go out and share that.
- 4.44 We need to acknowledge that we are loved by God no matter what ritual we are going through. I don't believe there is a wrong or a right way as long as there is an acceptance of Christ.
- 4.45 Through more knowledge and understanding I am able to see where ritual is an important vehicle through which the Holy Spirit speaks to us individually. At one point in my life ritual was all there was for me, but I rejected just having ritual because of the emptiness it gave me.
- 4.46 The most important part (of Mass) is the Liturgy of the Eucharist. (It is) a spiritual experience (of) worshiping God, being with the community and celebrating the Eucharist.
- 4.47 Christ chose the most normal and everyday event in his life as our example of the way in which we should live, he joined around a table for a meal. In that simplicity the power of his message lives two-thousand years later.
- 4.48 A second (sacred) symbol at LOW is open space. More than any one thing, sacred space is open. Specialness is not lost because we have room for everyone.
- 4.49 I almost said it (baptismal font) was (my) second highest symbol instead of open space, (especially) when there is water in it. It is symbolic of where we come from, earth, granite, cornerstone ... has an eternal quality, plus then the living quality with water.
- 4.50 LOW had done a better job with this symbol (tabernacle). Its not hidden away, but (it is) not a part of where we gather.
- 4.51 Tabernacle is (primary) symbol that is of highest spirituality and holiness. Location is significant at LOW (as) its the first thing that you see.

Parishioner Interview, Code 5.00

Environment

- 5.1 Did not like parents church. It was a box, a square bow. Early 60s when it was built.
- 5.2 (A previous post-Vatican II church), the space was high, you didn't get a sense of community. It is so big that instead of community you got the feeling of small groups. People always sit in the same place. You meet only those immediately around you.

- 5.3 I did not want to sit at the back of this (previous) church because you were too far away. You don't feel like you are a part of the worship service. The church was quite large and you always felt self-conscious, like you could get lost in such a big space.
- 5.4 LOW makes good use of the building space. They keep your interest. They make use of the building for the purpose of worship.
- 5.5 They (LOW) definitely use the whole building. They bring the architecture into the play of the use of the space.
- 5.6 At LOW we have sat at every corner (of the worship space)--you never feel like you are too far away.
- 5.7 Catholics who all have used pews know that, in general, pews are less comfortable. The rigors of the pews and the kneelers, you never felt like you were at your home--God's house, yes--but you never felt at home, or felt as comfortable.
- 5.8 (Altar) It is obviously the table where we bring our gifts and where the priest consecrates the bread and wine into the form of Christ and sort of gives us our last meal. As a symbol I do not concentrate on it.
- 5.9 Two things I look for in Catholic churches are a cross on the altar and a tabernacle--somewhere. These things take my focus, not the altar itself.
- 5.10 The altar is the setting, it is the table for the preparation, but it is not the purpose.
- 5.11 (At LOW) windows are placed just right to bring in sunshine and some warmth (not heat), but a warm feeling.
- 5.12 (Stained glass), at first it seemed like something was missing. Came to appreciate that LOW does not have it. Was usually used as an Icon. Did not usually depict warmth, as does LOW without stained glass.
- 5.13 The location of (the tabernacle) is significant at LOW. Its the first thing you see.
- 5.14 There is never a Sunday or a season when they (parish) don't have something on the wall, a banner or a mural.
- 5.15 Wood brings warmth to any house but you need to (accent) decorate properly. (At LOW) the wood platforms and the ceiling is the noticeable wood and is nice.

Encounter

- 5.16 My first experience (at LOW) the church seemed to be warm. We visited church at a time when no service was taking place, A caretaker was changing the furniture around.
- 5.17 One of the first things we noticed in coming to LOW, it felt more like being at home.
- 5.18 LOW's worship space encourages you to come in and talk. Its a home-like feeling.

- 5.19 I really do like LOW the best of all the parishes I have been at.
- 5.20 When a church doesn't feel alive, it feels dead, you don't want to be there.
- 5.21 (At LOW) people are just as friendly as at St. _____ but (at LOW) you feel like no matter where you are in the worship space that you are part of the worship service.
- 5.22 LOW is friendly but sometimes it can seem forced, like my first experience with the gesture of peace.
- 5.23 The priests don't speak at you--they really do speak to you.
- 5.24 The priests' (at LOW) have become one with the community.
- 5.25 He (The Pastor) asks you a question (from the lectern) and he wants you to respond.
- 5.26 (The pastor) does not allow the lectern to create up a formal setting, because in a formal way it would become preaching. The lectern allows people to focus. It is a supporting (element) structure to the reading.
- 5.27 I have always liked the pillars and needing to walk among them to get to the Baptismal Font. You have to choose your path to the font.
- 5.28 We have always felt wanted at LOW.
- 5.29 How they place the Hospitality Ministers to guide you (entry to worship) to the doors is important.
- 5.30 No pews (at LOW) gives me a feeling that it is more like a house type setting with a bunch of guests.
- 5.31 I liked it (visual projection system) from the beginning (and eliminates) songbook retrieval, (which) is a mess. They (parishioners) look up, people are taking in the building.
- 5.32 The shapes you see (circles and squares), you don't remember as being a Catholic church.
- 5.33 (What I like about LOW) is a combination of how they use the space and how they decorate it. (The) colors, carpet and the wood. The ceilings are not tall. The room does not feel like it narrows. It feels large.
- 5.34 At (previous church) I could definitely get away from it (the service) I could be distracted by every little noise.
- 5.35 My (Parents' church) did not feel warm, it had acoustical (tile) ceilings. They (these type of churches) were efficient and you got a lot of people in them, could heat and cool them but they were cold--psychologically.

Mystery

- 5.36 (At LOW) worship is a choice, you want to be there or its fun to be there vs. the commandment that you have to be there.

- 5.37 The Mass (worship) is basically a reflection of life in a one hour time frame. A preparation, welcoming, forgiveness - cleansing - purification - history (readings), teaching, then a celebration and leaving.
- 5.38 Worship--it is a celebration. A celebration of Life.
- 5.39 (Going to worship), my pattern is one of preparation, looking forward to a happy experience.
- 5.40 LOW wants the worship experience to be uplifting.
- 5.41 The priests are focusing on how we take our experiences of life and make them richer and fuller, to bring us closer and relate to other things going on.
- 5.42 By not having pews, that makes me feel more at home. You don't have pews in your house, you have chairs in your house. You should feel at home in the house of God.
- 5.43 (LOW--stained glass) LOW has done away with the humiliation from old church spaces. They (LOW) want the worship experience to be uplifting. For me sunlight makes it more uplifting than a humiliation.
- 5.44 Most dominant symbol is the circle. Whenever you want to get warm, you form a circle. You don't hold hands to form a box. It seems to bring in the community and the closeness.
- 5.45 In terms of a spiritual symbol, I think of a halo first.
- 5.46 I would prefer to have it (cross) in the worship space. The cross is what the church is all about, the whole Easter experience.
- 5.47 I have made use of the Eucharistic Chapel for private worship. The chapel makes me feel intimate. I like the space because it is not large and not lost as in a big space.
- 5.48 The chapel has high ceilings - similar to Gothic churches which I associate with places of worship.

Parishioner Interview, Code 6.00
Environment

- 6.1 (Is LOW a landmark?) Yes! You can say I live by LOW and people will say Oh! That Catholic Church. They don't say (refer to) Albertson's or Kentucky Fried Chicken. But people call it that church up on the hill.
- 6.2 A lot of people drive by and think (is that a church)? (they say) it looks like a dairy, monastery, or prison.
- 6.3 I wish when you drove by (on Bowles) you did not see that big blank wall. It looks like you're hiding from somebody. I would rather have somebody see the front of the building.
- 6.4 (The building) needs landscaping on the north wall.
- 6.5 We voted, or more like an opinion poll, on pews/chairs, where the cross was going, etc.. They told us about

- the space and how it (worship space) would be able to change (and would) have chairs.
- 6.6 There was talk like, this isn't quite what we thought we were getting. Maybe it wasn't quite what they (parishioners) had in mind, (maybe) because the ownership had not taken place yet. You can build any (type) building but whether you own it or not is inside (you).
 - 6.7 The building looks like something special is going on (inside).
 - 6.8 I like LOW because it challenges me, challenges me mentally.
 - 6.9 The best part of the building is the Chapel because of the light.
 - 6.10 I go to the church when there is not people around. Its nice when you are by yourself.
 - 6.11 (The tower) doesn't seem to be architecturally correct. The circle and squares come together which seems impossible, yet it works, which makes it interesting.
 - 6.12 (In the chapel) I don't think art should be gone.

Encounter

- 6.13 When the sun is setting you can see all the way to Boulder and all the way to the South (when standing in LOW's front yard).
- 6.14 You can always come back here (at LOW) and feel at home.
- 6.15 People who feel comfortable with LOW as their home use the coat rack.
- 6.16 Right after entering the church's front door I stop and scan the foyer to see who is there (such as) the coffee people, a cluster next to the Sacristy waiting for (priest) to make his appearance, and then you have the scatterers, who just meander, then there are those that almost knock me down as I am scanning.
- 6.17 I cannot be a hospitality minister and go to church at the same time. I must come back to church at another time. Its because I become involved (in my duties).
- 6.18 We went through the worst change that year and a half after we moved (into LOW). There was more anger, frustration, sadness, gloom at this (new) building than there ever was at (the temporary space). Because the people tried to make the building the church they forgot that the people are the church.
- 6.19 The only thing they do wrong in the way we do community is that we don't have enough things for people to do together for fun. We spend all our time working and working.
- 6.20 My preconception of what the baptismal font was going to look like and what it turned out to be was different. I had this vision of a huge rock with water running down, because they said how much money we were

- spending on this rock. \$3000! I thought \$3000 would give you a lot of rock. I have learned to like it.
- 6.21 Fr. Syrianev really pushed for singing.
- 6.22 (Singing) depends on where you sit in the space. Sometimes the position of when you have to turn around to read the songs seems awkward.
- 6.23 Newcomers are sometimes surprised by the strength of the singing.
- 6.24 For me (a special experience was) the Basilica (Denver Cathedral) it was all lit up, not dark, had lots of light and even though it has pews you feel you can move.

Mystery

- 6.25 I see (myself) as here, the world is over there (east to the city) and God is over there (west in the mountains). We are almost to God, but life drags you back, always, to the world.
- 6.26 God is in the mountains because they are beautiful.
- 6.27 The baptismal font I see as being full and light. I would love to go up and wash my face in the water before I go to Mass. The coolness of it, water, and seeing it overflowing if you are feeling warm and great you want to absorb that.
- 6.28 The Chapel is an easy place to pray. You can see that there is love there, and beauty in it, even though it does not have art in it. I don't think the art should be gone.
- 6.29 People at my _____ say that's (LOW) is just not a church. That it is not reverent to God. (But) we are reverent to God, the church (building) does not make a big difference at all. The church (building) is a place to go, to be with people that will give you support and feel like you do.
- 6.30 Father Frank always said the people were the church.
- 6.31 I can remember this (chapel) is where I am by sometimes looking at a symbol like the candle.
- 6.32 St. _____ was first place where I saw statues, they made me feel quiet. It was dark, I couldn't breath or move.

Parishioner Interview, Code 7.00

Environment

- 7.1 (At a previous church), from the main part (sanctuary) of the church we were way back. It seemed like we were far away from everything that was taking place.
- 7.2 (At LOW) I think people are kind of upset. You will be attending a dance on Saturday and then the next morning you are attending Mass. If we had an altar with a tabernacle then we would not use the space as a multi-purpose room. I think that is the reason for

having the Chapel so that you can use it (worship space) as a multi-purpose space. Some people have said that the worship space is too bare.

- 7.3 The doors into the worship space (on Sunday) are open I can see my way into the worship space. The entrance is set up (and) its obvious that's the worship space.
- 7.4 There are three different seating arrangements, Ordinary time, Easter, Advent.

Encounter

- 7.5 (Church community) means sharing in God's work. The building helps in this because of its openness. Its a home place.
- 7.6 (The worship space) its warm and that's the way your home should be, warm and inviting.
- 7.7 Fr. Syrianey, he was a tremendous giver of love. I think he was selected to begin this parish because of this gift. He carried a very heavy burden at the beginning (and) he did not want to share this burden. Had he asked for help it would have been freely given.
- 7.8 At the daily service (The pastor) sits with the people while someone is doing the readings. (It is) a sign that even though he is ordained to lead the service he does not put himself above us as people. He is with us as a person.
- 7.9 (Going to Mass) I leave the house and go the back way. I then always go up the middle sidewalk, (I have a) tremendous feeling of welcome (when) greeted by the deacon or priest. Father will come out of the (sacristy) and say Hi! How are you.
- 7.10 People that stay after the previous Mass will talk to you. Then I go into the church, to the Font and bless myself. I usually like to sit in the middle of the church.
- 7.10 I love the skylight (at the tower) its symbol is like a stairway going up to heaven.
- 7.11 The light comes in (chapel) and it feels like God is shining his light from heaven.
- 7.12 I like the (courtyard) cross, but you kind of have to look for it.
- 7.13 I like benediction (and) I like incense, but we don't use it that much!
- 7.14 One of my biggest memories as a child was going to Midnight Mass. They don't celebrate Midnight Mass here and that is sad. Christmas time is beautiful (however).
- 7.15 When LOW was started more women came forth (to help) and Fr. Syrianey gained respect for them.
- 7.16 (At baptisms during Mass), they first bring the parents and God-parents up and introduce them to the community. A procession (to the font) and then they go back to their seats.

- 7.17 (At least liked church) I felt segregated, a feeling that she got when she went to that church. Felt it was a status church. Felt like she did not belong there. (This church is a post-Vatican II designed church.)
- 7.18 An older priest I know, he is old Catholic. His views are that way and one never changes. He would be taken back looking at LOW. The old priests would have trouble letting go and letting people become involved, particularly in the service of the Mass, and particularly with women. (Our pastor) does not have that problem.

Mystery

- 7.19 Because of the way the liturgy is expressed at LOW that is one of the most beautiful features.
- 7.20 The host and the chalice are the most sacred parts of the mass. The changing to the body and blood of Christ, that is the beautiful part of our celebration.
- 7.21 The whole church is very much sacred.
- 7.22 The chapel is just beautiful, I have liked it since I first saw it because it was "just so holy" it brought me back to my childhood. The light comes in there and it like God is shining his light from heaven.
- 7.23 Church (and) spirituality, LOW gives me that. The spirituality abounds out of LOW with the community, because of the genuineness of the people. It is with love that they approach you. A caring feeling, not (just) a passing comment made on Sunday morning.
- 7.24 (What does the space require for spirituality)? The community.
- 7.25 On Sundays I have a different feeling about being in the worship space (as compared to the Chapel). The openness of worship space brings somewhat more spirituality.

Parishioner Interview, Code 8.00

Environment

- 8.1 (The worship space as a multipurpose space) I like utility, everything from utility vehicles to knowing how to use something several different ways.
- 8.2 I think that (worship is enhanced by (having) chairs. I think (not having pews) that helps a lot.
- 8.3 Two main seating arrangements. Each has its own advantages, Easter allows you to have a stage like effect, a nice wide aisle. At ordinary time the people are sitting around (the altar). I like that.
- 8.4 (Easter seating arrangement) makes you feel a part of a smaller group. It does (make me) feel like a smaller group.
- 8.5 Everyone sits in their own place each week, and a lot of early people do sit at the northeast section. It is

- close to the altar, you get to see the priest and the actors a little bit more than out in front.
- 8.6 I like the flexibility in the church. I like it to be a multipurpose (and) to still know its a church.
- 8.7 At the school (temporary worship) I use to set up the chairs and I mentioned to Father once, I will be glad when we get over to the new church and we have pews. He did not say anything. I was real surprised that we didn't (have pews) but more and more I like it.
- 8.8 (Altar) Ah, that's where the sacrifice is held. That's the dinner table. I like the one we have, because it makes that (statement) clear.
- 8.9 Altar, lectern, what strikes me is the workmanship. They are interesting sculptures just to look at, as simple as they are, the workmanship that they did. I just look at them over and over looking at the way all the joints went together, the strength yet simplicity.
- 8.10 (At baptismal font) The mobile is up too high, its too far removed from the floor. I don't think it comes off well enough.
- 8.11 (There are a lot of things happening in that little space.) Yes! Those poles are mighty massive, walling off, too. People will walk around it rather than through it.
- 8.12 The fire and wind are hidden. Nobody sees them. The candles, as far as I know, have never been lit. And I have been there since day one--almost.
- 8.13 Even though its (mobile) placement is right where you could walk right by it, I don't think it is visible. You are looking into the space when you come in and not up there. I think more people see it when they walk out and you don't make the connection.
- 8.14 I remember basically (it was said) to not put anything (ornamentation) in here (worship space) right now, live with it and then see what you want to do. But we have been here three years and still we don't have a (permanent) cross.
- 8.15 I dislike the lack of blinds, (ability to control natural light)? Yes!
- 8.16 (For worship at night compared to daytime), the slides are more effective. There is a lot more flexibility. Things you can block out if you want to do something with the reader or the choir or the altar, or frequently what they are doing, at lent (with plays). The use of lighting is more effective.
- 8.17 My biggest sore point in that church with me is the cry room. I spent time there with _____. You cannot hear anything. The loudest setting (on speaker) is not loud enough.
- 8.18 I like the Chapel a lot. I like it a lot. I like the wood floor, I like the intimacy. I have never been to a service in it at all, but I like the light area, and

its very warm feeling in there. They turn on the lights but I don't see a need to, I like it the way it is--its very appealing.

- 8.19 At my parent's church, after Vatican II they still had the large altar up way high, then they brought a smaller altar out into the front of the sanctuary. The communion rail still exists.
- 8.20 Its (parent's church) different now and almost sad, its very empty, very quiet, no participation, no warmth.
- 8.21 I like a lot of stained glass (in a church). At LOW when I first went in there, I said, what does this (space) remind me of--a puritan meeting hall. I have seen the high windows, I have seen this all before.

Encounter

- 8.22 This is the first Parish I have really gotten involved in and that says a lot about the way LOW is.
- 8.23 There is something about being needed in this church, and there is something about your not being afraid to do something. I am not sure why that is, I never felt the need (before) to do anything.
- 8.24 One of the changes at night is the special liturgies, holy week, etc.. People are there because they want to. You get different feelings.
- 8.25 Upon walking in I (am) concentrating on just walking in (to the worship space), those people I know, I just say Hi!
- 8.26 (For worship) I go in the first set of doors and I immediately bear to the right. I avoid the fountain (baptismal font). I would go off to the side and sit in the same section (northeast) as always.
- 8.27 Those poles (at baptismal font) are mighty massive, walling off, people will walk around it rather than through it.
- 8.28 (When you walk in what main objects do you see)? I will skip the gallery. I hardly ever see the gallery. When we had those (Easter) banners there I wondered how effective it was. Walking out I notice the Gallery, walking in I notice people.
- 8.29 Its funny with the chairs you (would) think it would separate (people), but because everyone has their own space and something about seeing the other people, somehow the visibility is more. You feel there is more of a oneness.
- 8.30 Considering the alternative of looking at a person's back of their head, you see (at face-to-face seating) their face. It is interesting to look at who is here. I don't think it distracting.
- 8.31 Standing up at the liturgy of the eucharist, that was really tough to get use too.
- 8.32 I really like (however) not using kneelers, I like that

- a lot. It takes a lot of hocus-pocus out of it.
- 8.33 I think the (worship space) works pretty well. I was going through the parts (of the service), the introductory, the way it is, you feel very close to the people. Not only are you introducing the Mass but you are introducing yourself. That's where a lot of the warmth comes, in the people.
- 8.34 The foyer, for everyone to meet and gather before church, it does work well.
- 8.35 At some of the seating set ups you can not see (from the cry-room), you really can only try to hear, you are not part of the Mass. For that reason you are seeing more and more kids out in the (worship) space.
- 8.36 Frequently, I have gone to several churches in schools and things (places) like that. The casualness seems to affect the people, they drop their pretentiousness.
- 8.37 (Before) going to church you did not get anything out of it, it became a habit,...you did not go to church because you wanted to. That's where a lot of the problems are, and its still that way.
- 8.38 The development of community has to happen not just because of Sundays, it needs to happen at other times.
- 8.39 I think it helps (to have activities) after Mass. Catholic people will not go early to Mass, matter of fact they would rather come late.
- 8.40 I don't know how I feel towards this wheel (parish committee descriptions) but it is not at all what I thought a parish would be like.

Mystery

- 8.41 My wife is not Catholic and she is put off by this standing up, kneeling down, back and forth, (she says) are you exercising or what? I find that very interesting. I never thought of it that way. I never thought of it as a ritual.
- 8.42 I would say that LOW does not (give sacredness). I don't get sacred feelings. I get something that strikes me as on a daily basis. When I think sacred I don't think of the real world.
- 8.43 There is a difference between sacredness and specialness, you get specialness (at LOW) but not sacredness.
- 8.44 I think a place is sacred because the need to be quiet in that space.
- 8.45 There aren't any permanent ones (symbols) there that I can think of, other than, the baptistery, that's neat, I like the earth, fire and wind. I don't feel (however) it comes out to people that don't know what its about.
- 8.46 The children liturgies are either a demonstration, skit, or they (children) are given something to do at the sermon. Generally it is the children who are the ones that put on the liturgy.

Parishioner Interview, Code 9.00

Environment

- 9.1 At the church where I grew up, from the main part of the church (sanctuary) we were way back. It seemed like we were so far away from everything that was taking place.
- 9.2 I think the whole design of the church (LOW) is unique. Its very, very pretty with the courtyard, the baptismal font, the big foyer, in front where people can stand and talk (and) big enough to hold all the people. That's unique because lots of churches have just a little cubical and you either stay in the part of the church you should not or either you are outside.
- 9.3 The building (design) does not make the church, it enhances it.
- 9.4 (LOW as landmark) I don't know. It still seems new to me. Tonight the friends I had over at my house, they live west of here but on Bowles, which the church is on, but I did not remember that it is Bowles. I had not seen them for months. I was explaining and asking if they knew where the church (LOW) was with this and that, and they said yea, we are just down that street, you go to this street, then that street, they knew exactly where the church was. The church on the hill, yea.
- 9.5 Church is about families and I don't think the church should have a cry room. But I have never been without children or small kids. I don't know what it would be like for a person without children to be in the same space.
- 9.6 Children and crying and all that, its part of life, that's what life is. its family. I think a cry room removes the kids from the church. I think the kids ought to be left in the church.
- 9.7 At LOW there really are not many people going into the crying room. Most of the small children are out in the congregation. So its a waste of use. They really don't need it.
- 9.8 One day I stood out in front of the church. I looked at them (flag banners) and I thought I should see something here, but I did not see anything. I did not feel anything because of them. It made me feel good that they were pretty and bright waving in the wind, but I was sure there was supposed to be another reason.
- 9.9 I have walked in there and seen it (tabernacle) and wondered what the room was for.
- 9.10 I think it (worship space) would be enhanced with stained glass only because I identify that with a Catholic Church.
- 9.11 Church: stained glass, statues, stations of the cross, first you got God, then these other things, that's (ornamentation) is what makes a church. I think you

would probably feel better in the church if that stuff was there. I would feel more with God maybe, if these things were around me, that I could see. You can not forget what has brought us to this point, you can't forget all these things back then.

Encounter

9.12 I like to be up close and participate.

9.13 (Before Vatican II) in Latin, I had a very hard time understanding what was going on.

9.14 I was never able to experience as much back then (pre-Vatican II) as I do now. Today I think the congregation has an active participation in the Mass, while back then you did not. It was really hard to take any interest into the Mass.

9.15 (For seating) I sit as close to the front as I can, and not much to the side.

9.16 I always try to relate to my kids and the fact that they are little and it is hard for them to see what is going on.

9.17 I don't think a child is ever too young to not be in the worship space. To be in the atmosphere, that is important.

9.18 (Sitting in the back) I am not as close, as a participant, you really can't in the back. I can't see over the heads and I really feel uncomfortable in the back. You get very distracted because you can't be very close.

9.19 (Concerning arrival), you drive up, you go through the two main doors, you go to the holy water and then you find a seat and sit down. I have never done anything special when I walk in, because we are always just there on time. We are (however) never late.

Mystery

9.20 (Not participating in worship) is like going to somebody's house for dinner and not sitting with them. You are sitting in the kitchen when they are eating in the dining room.

9.21 (To participate) you need to be as close as possible, that's what going to church is like.

9.22 I have never thought about symbols. When I think or picture the church I am trying to think of a symbol or something that represents that church (LOW). I can't see one. I see the church as a lot of people, and God being there, not as a cross or as a statue.

9.23 (Altar), it is just the place where the priest stands. That is his part and our part is out here. I have never thought of it as having a symbol or meaning.

9.24 This church (LOW) and St. _____, that's where I use to live when I first got married, give me that sense (spirituality) because we were so much a part of it. I

was starting my family and we belonged to the church, we belonged there. It was not the structure, because it was an ugly church, it was like a box with an altar. I think it was a time frame in my life.

- 9.25 I don't think the structure has a lot to do with it (spirituality) I really don't. I think its where the people are, its where God is, its not the structure that you are in, because until you asked that question I had not thought about how much I did not like the looks of that church.
- 9.26 I think communion is the greatest spiritual experience of the whole Mass. I think at that point (more so than) the whole Mass, you are the closest, for those three minutes, closest to God.
- 9.27 I remember as a child and we came back from communion, we were told that this time was a very special time and we should thank our God for having received the host. I used to force myself to concentrate to get a really close thought. In this (LOW) experience I really don't find that time to try and be really close to God. I don't because I go back and sit down and relax, my mind starts wandering.
- 9.28 I remember sitting as a (child) and every time you could look up and you could see all these things. You would, maybe, not be paying attention to what was going on but your mind would be with the church and with stations of the cross, that stained glass window of a saint.
- 9.29 Its ideal to have that little space (eucharistic chapel) for special sacred types of things, where you don't have parties or meetings, that's great. I did not know that's what it was for.
- 9.30 Without question LOW is the most beautiful church I have known.

Parishioner Interview, Code 10.00
Environment

- 10.1 I think that (LOW) is OK because that's telling the congregation we are keeping up, we are keeping up with the world, we are not an old time type of church.
- 10.2 I think the design of the church tells people that we are modern and that they want modern people to be there, and you can come and be modern and be you, with your open thoughts.
- 10.3 In the older churches you have old ideas.
- 10.4 I don't think the side of the building towards (bowles avenue) is inviting to the public. It is like you are seeing the back side of it (church) and no one really knows what the front looks like.
- 10.5 I was taking a co-worker home the other day, and we

- were passing the church. I said don't you think its a beautiful structure, and I thought you can't see the beauty from this side. I had to take her to the front to really see the church. They should have built the building turned around.
- 10.6 I felt it (worship space) was very plain when we first moved in, as far as not being similar to a traditional church.
- 10.7 The mobility of the worship space, I think that is real unique. The seating arrangement and everything, people looking at each other.
- 10.8 (The Easter seating arrangement) People are looking at each other, you are not used to that, and its real interesting. You look across and people smile at you. That's kind of neat.
- 10.9 Sitting in the back I find it hard to concentrate on what is going on.
- 10.10 When I think of stained glass, I think of older churches, like in Europe or the Pope. When I think of the Pope I think of stained glass.
- 10.11 (Should LOW have stained glass) No! I like that light streaming in those clear windows. I like that its very pretty. I have no objections to stained glass. Its very beautiful, but I just kind of like the way LOW is done. The natural light coming through. If they want to add it somewhere else than the worship space, in moderation, that would be all right.
- 10.12 The only permanent part of the structure is the baptistery.
- 10.13 When I first saw the (Baptismal font) I did not see this (mobile) right here. I saw the posts. I did not even look at it.
- 10.14 I think the tabernacle is very small.
- 10.15 Some babies cry more and they need a cry room. When the child gets to the point that they appreciate the Mass then its the parent's obligation to take them into the worship space.

Encounter

- 10.16 I never felt so much a part of any church as I have with LOW, its the people, not the structure.
- 10.17 Fr. Syrianey is the reason I am active right now in the church. I wasn't before, but it was Father Frank who actually got me so involved in it.
- 10.18 His (Fr. Syrianey's) intent was not to have any distraction. He wanted people to pay attention to what was going on and to participate without fumbling through a book.
- 10.19 Back then (pre-Vatican II) it (service) was in Latin, you did not participate, you were not a part (of the service) like you are today.
- 10.20 What is important is that you are there (worship),

that you congregate with these people, that you share with these people and that you pay attention to the liturgy.

10.21 (At LOW) you don't need a prayer-book or a missal or any book to go (guide) by. The other parishes all have these books out to follow during Mass. Here you stand there and watch, you don't need the books.

10.22 How LOW puts the words (for singing and prayers) on the wall, that's unique. Usually someone would say turn to page 34 we will sing _____, the song would be half over before you found it.

10.23 (Upon arrival) we drive up we park, we say hello to people in the parking lot, we say hello to people in the foyer, we say hello to everyone. That is really the fun part of going to the liturgy and the Mass every Sunday.

10.24 I usually take the center path all the time, unless its really packed like on Easter or Christmas. Then, I take the quickest path. Even though I have an option I want to walk down the middle.

10.25 (As a hospitality minister) its interesting to watch the people towards the end of Mass. Its the people who sat in the back that are out the doors before Mass is ever over. They don't feel it yet or else they would not sit in the back.

Mystery

10.26 Having been forced as a child to go to church, and that is what it was, I was just simply forced to go to church. I learned a lot about the church and I participated never to the extent I have participated at LOW.

10.27 I have never felt that close spiritualness with the church as I do today with LOW. I think the reason is Fr. Syrianey and Fr. Mancini and their closeness with all the parish members that makes me feel so close to God today.

10.28 When we first moved in (LOW) there was nothing but white walls, no banners, no color, nothing. A lot of people were disappointed because they grew up in other type of churches. They felt they could not find reverence there as found in old, traditional churches. I tried to tell them it would come in time.

10.29 The Baptistery, that has got to be the most beautiful part of the church. I think Fr. Syriani's intent there was to think light, water, fire and air.

10.30 Its the first thing that hits you when you first walk into that structure and it is very symbolic. A (long pause) kind of introduction to the church, it symbolizes new life for a member of the church.

10.31 (Whenever at previous pre-Vatican II church) I was in front of or beside the tabernacle I know that is

where the hosts are at and I know that you need to give the greatest reverence. That was the thing of the whole church, the whole church was (always) built around that tabernacle. The biggest thing was that little box right there.

- 10.32 At _____ they use to lock it (tabernacle) and I think it was just an indication that was a very reverent place.

Parishioner Interview, Code 11.00 Environment

- 11.1 Stained glass, it doesn't matter, I just never grew up with it, its pretty but it really does not matter.
- 11.2 In the older churches the podiums (lectern) were always real high up. It seemed to raise them (priest) above the congregation. I don't like that at all.
- 11.3 This is my favorite part (tower), I like to stand in here and look up and know from the outside that the light is going down.

Encounter

- 11.4 We (LOW) started in a gym, we were a poor church. We had everything on a transparency and projected the music on the gym wall. That's the way it used to be. And that's what they wanted to do was transfer that idea to the new church.
- 11.5 The foyer they built that so people could congregate and talk and share with each other, and then go in and share with the Mass.
- 11.6 What I like is where everybody holds hands and (we say) Our Father. That's new, really new, and I like that. If you are sitting next to a stranger and you grab their hand it makes you a lot closer to them.
- 11.7 In a store you would not turn around and grab someone's hand.
- 11.8 As a Hospitality Minister I have to force myself to be part of the Mass. I am really watching people, making sure they find seats, making sure they are comfortable, that people aren't making noise or playing with the switches on the lights. Its very distracting. I have to concentrate on what Father is saying, what the readers are saying.

Mystery

- 11.9 (Ornamentation), it does not matter to me, I didn't grow up with that. The way I always think of a church was (is) never with statues.

Parishioner Interview, Code 12.00

Environment

- 12.1 (Previous church) The altar was removed from the people (and even though the position of the altar) has changed they cannot change the way the church is made. People still are at the back.
- 12.2 The altar space for most people is very special, as it should be, but it should not be so removed that they feel uncomfortable when they (parishioners) come up there, at least psychologically.
- 12.3 You can have the most elaborate or simple type of church, but there needs to have a priest (for the church to be) in focus. But you can never find a perfect church.
- 12.4 The north wall (makes LOW) look like a prison. The structure, it catches my eye because it is so unusual.
- 12.5 The steeple, it always (has) bothered me because it looks crooked.
- 12.6 Wherever you are driving you can always see it (tower).
- 12.7 When I first come in I see the Chapel first.
- 12.8 It has bothered me that the chapel is removed from the church (room by itself). You can't see this from the outside, it confuses me (and) is a mystery.

Encounter

- 12.9 A most vivid memory (previous church) is the vivid colors in a Southwestern church. The main worship area was very colorful.
- 12.10 In the old pulpits they (priests) went up so high to preach that it was (as) if they were in heaven and we were down on earth.
- 12.11 The baptistery, it strikes me as being important.
- 12.12 When they (LOW) have the flags out that strikes me the most.

Mystery

- 12.13 As I am in the chapel spaces and at LOW right now, you are stepping on holy ground, as anything that pleases the Lord is holy ground.
- 12.14 You have to look at God wholistically, something that is positive to be achieved.
- 12.15 As a child, the sacristy (sanctuary) felt scary to be in, it was dark and so far removed.
- 12.16 Passing in front of an exterior cross, older Catholics would make the sign of the cross.

Parishioner Interview, Code 13.00

Environment

- 13.1 (Did you see plans periodically during the planning process?) No! It is my recollection that we did not

- see anything until the final plan. But there was a planning committee and they had a real good idea of what we wanted. With good advice from outside people.
- 13.2 (LOW) is recognizable as a church. Its a big facility that can handle lots of people. But then its different because of the symbols, different concepts for the symbols.
- 13.3 From the street side I think the church reminds me or I think about Noah's Ark.
- 13.4 I am pleased with the way it looks from the outside and that it is of the new era. That's to say, one thing you could say about Catholics up to now was that they were this way, well you can't do that anymore, we are something different.
- 13.5 I think the baptismal font is the most important element.
- 13.6 I think that's (baptismal font) the center, both inside and out because of the tower.
- 13.7 (The chapel) seems to me to be the heart of the church. Its a special place. Whatever the reason is I don't know. You look at it and it appears to be a church within a church.
- 13.8 (Altar) Its simplicity. The Mass is supposed to be thought of as a meal. To eat you gather around the table. That's all it means to me, the place where you break bread or share it.
- 13.9 I think there are places in the church which are blank. I think in a conventional church there is more.
- 13.10 One thing about LOW, it is not rigid, we can do things to it.
- 13.11 As far as pews go, why do you need them, unless its tradition. With chairs you can change them around to suit the seasons or your needs.
- 13.12 We did not want statues in the worship space but that does not mean statues cannot go in the gallery or foyer.
- 13.13 When you can take the time to look at the church and come up to it, its pretty awesome, especially if you know what the symbols are and what it took to build it.
- 13.14 We got actually what we asked for in this church (LOW) and maybe even more.
- 13.15 One problem that I have with the building (LOW) is its so simple that maintaining the building (is hard). We could have used better wood or not used wood at the south. As far as design goes I don't think its at fault. It was the amount of money available.
- 13.16 (A previous church) was I guess would be described as your conventional Cathedral type. I like that style, I always liked that conventional style or what I feel to be a conventional style. I grew up with it so I like it.

Encounter

- 13.17 Time and talent at LOW is that you donate your time and talent. You say you have an ability or abilities, such as being experienced in public speaking, acting, they would be asked can you donate your time and your talent to help us.
- 13.18 You have to be careful, it (reading) should not be an ego thing. We don't want it to be about that person, we want it to be about the word. Yet we have to have people good enough to proclaim it, which takes some amount of pride and you can't do a job well without that (mental attitude). Its a fine line.
- 13.19 You know a lot of people bring the book up and get it opened up to their place. I don't do that, I think its important to open the book just before you start reading.
- 13.20 I think the building enhances the concept of community, the foyer is a place to gather, there is lots of room to gather and it encourages (one) to do that.
- 13.21 The (foyer space) was done deliberately to promote gathering, (for) people to mingle comfortably.
- 13.22 A problem (with gathering) is that we are not allowed too much time between Masses, because you have to get that parking lot cleared and let the next group come in.
- 13.23 If you go to the same service every Sunday you see the same people, you go to a (dinner or dance) or something like that you see different people.
- 13.24 (I like the Easter configuration for seating) I think it puts people right there, and that configuration lends itself to the liturgies we are doing. It puts people closer together.
- 13.25 Other things that I am extremely happy with that building are the sound and the visual aid system, that lends itself to anything we want.
- 13.26 I don't think its easier to see in the back, especially sitting down. I don't think the altar is too far away. Where I don't like to sit is over on the sides when you (have to) sit sideways. You don't see as well there.
- 13.27 One of our (LOW) basic concepts was that the color, the atmosphere, was not the churches job, it was the people's job.

Mystery

- 13.28 To be better Christians as opposed to Catholics, I think that is important to this new generation of Catholics.
- 13.29 If I can find a problem with LOW its that the symbols are not apparent, they have to be explained. In most churches you have a statue of somebody.

That's perfectly symbolic. You know who the statue is for.

- 13.30 I think until its explained very few people see the symbolism in the baptistery with the earth and fire, air and water.
- 13.31 Once they (symbols) are explained and you start looking and thinking about them its then a good place (LOW) to meditate.
- 13.32 Its something you have to contemplate, its not just there like in most conventional churches and I think that's another indication of people, in general, coming of age. Now, whether we are or not, we are perceived to be more mentally capable of (making up) our own mind.
- 13.33 Another concept, (tower) takes in light during the day and giving off light in the night. It does a good job of that.
- 13.34 The difference (between pews and chairs) I think a lot of it is psychological. In a pew you can't get anywhere. When you have chairs, whether people want to or not, I think they feel like they can get out and greet other people. Especially if you have a few people that will do it. With pews you just can't do it. It is physically impossible. With chairs you feel you can move and go to anyone you want.
- 13.35 You know, the one thing that I like that people might say they don't like is that we don't have kneelers. To me when you have kneelers and people kneel down at the concentration that does not put our God at our level, it puts us below his level and I don't think He ever intended that.
- 13.36 There seems to be a respect for that area (Chapel). People tend not to go into that area unless they go in and pray. Well the way the church is built it is like that's the heart of the building, so that commands some respect. People just (by intuition) know that is a quiet space.
- 13.37 I think a lot of our style and the way we celebrate now is influenced to a great degree by Walsh (liturgical consultant). Not only directly by him but by the way he influenced Fr. Syriani.
- 13.38 The church I remember most is the one that I went to school for 8 years at, a Catholic grade school. We went to church every morning, Mass every morning.

Parishioner Interview, Code 14.00

Environment

- 14.1 I figured it was a church. You can kind of see above the chapel a little, and then I saw the sign and said Oh gee, that's interesting.
- 14.2 Before coming to LOW, I remember driving by on Bowles

and saying that church does not have any windows. Then, I saw it was a Catholic Church. What are they trying to do here? My first impression was that they were closed off to the world (Which) they were suppose to bring light to. I think they should have put windows on the other (north) side.

- 14.3 I feel welcomed because you feel more freedom to move around with this type of furniture over pews that are forever in the same place. You feel like you are at home.
- 14.4 The (Courtyard) is too small for as many parishioners as we have for something like the pancake feed.
- 14.5 They could use it for an outdoor mass if they wanted to, which would be nice.
- 14.6 I guess you are not supposed to go to reconciliation because its not very inviting to reach that space. The idea of reconciliation is not to be such a chore, but what this implies and this interrogation from florescent lights in (the room.) What they need is more comfortable chairs, a table, table lamps, no overhead light at all. And please, no phone.
- 14.7 I think these banners that are red and blue on an aluminum stand don't mean anything and it detracts from the altar. It just sits there for decoration like in a Protestant church.
- 14.8 I don't mind the back banner because it means something. I like this banner because it is the mountains and we're at the base of the mountains bringing forth the Light of the World.
- 14.9 I detest florescent lights and in this space (LOW) it make you feel like (you are in) a gym.
- 14.10 The candles above the font, four levels of lights --which doesn't mean anything particularly. Its just a piece of artwork that you have to look at and it doesn't mean anything. They don't light it. If you are going to invest in something you may as well use it.
- 14.11 The (Easter) cross (should not) be too big because the altar is the focus. That's what we are here for.
- 14.12 The space is simple, I like that because it reminds me of architecture in Jerusalem.
- 14.13 I like the wooden ceiling.
- 14.14 I really wish this room (worship space) would have as much light as the chapel. You feel welcomed to walk right in.
- 14.15 The church is so symmetrical and simple yet you come in here (under tower) and it is so complicated.
- 14.16 Here is a big line going around us (sound absorption panels), it seems like it is separating the people and heaven. We can see out those hugh windows, what we are aiming for, but we can't get there because of the sound material around here.

14.17 I think it (courtyard) is a waste. This cross has always felt very massive and there is something about it even though it is a cross, it just feels too large for that part.

14.18 This is (not) a good idea (cry room) but if everyone who had a baby were at the same Mass they would (more than) take up the complete room. This is a parish with lots of young families. The room does not open into the worship space, so it says too bad you are not in here, especially with these columns.

Encounter

14.19 The music here is at a tone where everyone can sing, it is not overpowering.

14.20 When you have the chairs like that (Easter arrangement) you have to hold your head like this to see what's going on and it really is an uncomfortable position. The nice thing is that you can see more people.

14.21 At Lent and Easter I felt well here is this nice cross and these people that's great but I have this crook in my neck when I am looking at the altar. There is nothing to focus on, I was wondering why were we here. I think you have to be comfortable in order to worship.

14.22 This is a good idea that you go through the baptismal font before you go in (worship space). You are renewing your baptismal promises. I feel like I am cleansing myself. But it is way too small for everyone to go by and upon leaving people don't participate in it after Mass, which is a mistake.

14.23 I think you feel more of a community if it (worship space) is smaller. That's why I like this church.

14.24 LOW's identity is its smallness and closer community.

14.25 Prior to Vatican II people complained that Mass was in Latin and you were told to stand, sit, sing, stand, sit, sing, (etc.) and there was nothing else. When LOW projects the words they are doing the same thing, telling you what to sing, pray and what to do. You don't do anything on your own free will.

14.26 In the future (after expansion) the altar will be right under the projected words. Its like we are performing a ritual and we have the words right above us telling us what to do. I don't like it.

Mystery

14.27 With padded seats you feel warm and you are comfortable physically so you can mentally and emotionally be with the people and with what's going on. With straight back pews you are not supposed to move or say

- anything or look at another person.
- 14.28 LOW symbols (that have meaning) are the water and the Easter candle.
- 14.29 In the middle (of worship space) they have this cross, which technically has no meaning, I mean the altar is the focus. Before Mass and after Mass they (minister) bows to this statue, so the first thing a Protestant comes in and says they are still worshipping statues. So I don't like that myself.
- 14.30 With the tabernacle and the candles you know there is something going on. You walk in and you see it as soon as you walk in the door. The main worship space doesn't seem as special when I know they had a dance in there the day before, even though the altar acts as a focus.
- 14.31 They had a dance right here in the worship space. No thank you, because it doesn't feel sacred enough if you are going to have a dance in it the day before or the day after or the day of the eucharist.

Parishioner Interview, Code 15.00
Environment

- 15.1 I think its so a very Protestant looking church. I remember my first experience at LOW. My daughter and I came here and there was no (outdoor) sign saying what kind of church. We were told LOW was suppose to be here but we did not know if this was the right place being our first time there. There was no cross, no statues, no ornamentation except for a rainbow above the altar. I thought it was for sure a Protestant church. No pews, no kneelers, everything was totally wrong. I said to my daughter we will leave after it starts if this is not the right place. The service started with the priest in his vestments, then, we were sure it was a Catholic Church.
- 15.2 So it is a totally different church experience for people like me who are trying to put together the lack of information they have received from Vatican II and the good feeling that we need in a society we have today.
- 15.3 The worship space is one hugh white canvas with a lot of space, waiting for someone to come in and mold it. Small changes don't affect it, its just too big.
- 15.4 As the space goes if you took all the chairs out it would be overwhelming.
- 15.5 With nothing on the walls it (worship space) can feel like a barn. Without the people it would be just a big pole barn.
- 15.6 I think like any church, its decoration is by the people.

- 15.7 I think (LOW) is a good worship space because it changes my point of view, it is not structured. Literally, we can change configuration and chairs and totally change my direction within the worship space.
- 15.8 I don't think we have fully utilized that space yet, every year we do more and more things, it is only as limited as the people use it.
- 15.9 The (worship) space welcomes you because it is open. My toddler, because we don't have kneelers, she has this little space that she can sit down on the floor. I think its real important because if the community has no children, it has no future.
- 15.10 Before going to LOW we attended a Catholic Church that made us feel very alienated. We felt our children were not even desired or wanted in the worship space. They were suppose to be in another room.
- 15.11 (Chapel) I think it would be better if there was some sort of doorway to keep out the distractions. It is so open. Every time I have gone in someone will come in and start talking to me, rather than realize that this is the place where you want to be in silence.
- 15.12 We need a sign to locate the confessional (reconciliation chapel). At LOW you first have to know where everything is stored, then you know where the reconciliation chapel is at. I think it is one of the poorest designed spaces. Even if there was room to store everything I don't think it would be a nice (location) for that room. It reinforces the statement that it is not reconciliation but is confession all over again.
- 15.13 One thing that would be helpful in the cry room is to have something that will restrict the children from leaving that space.

Encounter

- 15.14 My worst experience was in New York in an old church, we got there and no one was responding, it (Mass) was over in fifteen minutes. No one shook our hands at the sign of peace. Even when we did participate we felt like we were not suppose to.
- 15.15 I am still looking for (closeness of community) at LOW, maybe LOW is to large.
- 15.16 One of the best Masses I have ever attended was outside, even with a whole bunch of kids screaming. It was because of the participation.
- 15.17 The other thing I like is the banners that go outside. When they are up they are tremendously inviting and bring you right into the space.
- 15.18 The Baptismal font reminds me of Moses striking a rock and water coming out. Sort of life-givingness. I know that we are suppose to walk through there and enter through a renewal of baptism, but it necessarily does not give me that feeling.

15.19 The courtyard has a quiet Gethsemane space, a kind of attitude, a prayerful place to be. Without walls there is no hiding, just you deep inside.

15.20 Visually it (cry room) is not terrific. I have actually been there when two microphones were being used and you were only hearing one. It was horrible. You are very isolated back there, most cry rooms are like that but this one is even more so. It made me so upset I almost said to heck with you, I almost decided not to go back to LOW.

15.21 Children can not get God if we send them away all the time. That's not what God wanted, he wanted children to be there.

Mystery

15.22 For those people brought up pre-Vatican II, with the prayer books, the devotions, all those things, which still have a place, they are going to have a very hard time until they can come to the fact that the God in the people is the most important thing to get out of the worship service.

WORSHIP LIFEWORLD
AND
POST VATICAN II CATHOLIC CHURCHES:
A PHENOMENOLOGICAL INTERPRETATION OF
LIGHT OF THE WORLD CATHOLIC CHURCH, LITTLETON, COLORADO

by

ROBERT DAVID HABIGER
B.Arch., Kansas State University, 1971

AN ABSTRACT OF A THESIS

submitted in partial fulfillment of the
requirements for the degree

MASTER OF ARCHITECTURE

Department of Architecture
College of Architecture & Design

KANSAS STATE UNIVERSITY
Manhattan, Kansas

ABSTRACT

In 1963, Vatican II--a worldwide meeting of the Roman Catholic Church--produced the document Constitution on the Sacred Liturgy, which initiated post-Vatican II liturgical reforms, including the design of worship spaces. Fifteen years after Vatican II, United States Bishops published Environment and Art in Catholic Worship (EACW), the first official text on the planning and design of new worship spaces.

This thesis examines, Light of the World Catholic Church, Littleton, Colorado, which was designed using EACW. The thesis took a phenomenological approach, focusing on worship lifeworld, which is the unself-conscious taken-for-granted pattern of people in a place of worship. First, the thesis provides an interpretation of EACW and argues that it focuses on three major ideal themes of environment, encounter, and mystery. These three themes are used as an organizational device for exploring and evaluating the relative effectiveness of Light of the World as a worship lifeworld.

The thesis concludes that Light of the World had those qualities considered essential to the environment theme. The worship space is a one-room space which follows a domus ecclesiae archetype of gathering space. The most noticeable physical characteristics are the simple less ornate worship

space, baptismal font, movable seating and altar furniture, and the tower, which establishes the church as a landmark.

When compared to the ideal for encounter, Light of the World also meets a majority of the critical issues. The research concludes that active participation, as a product of community experiences, appropriately occurs in the worship space. The research also concludes that the social structure of the parish makes a significant contribution to this overall active participation and involvement of parishioners.

Light of the World is not completely successful in providing the essential elements of the mystery theme. Several parishioners' sense of spirituality is still linked intimately to memories of older, more highly ornamented Catholic Churches. While these parishioners' felt that the worship space would have a greater degree of sacredness with more liturgical art, younger parishioners felt satisfied with the less ornate worship decorations.

Light of the World represents progress toward the ideal post-Vatican II church but weaknesses are apparent which should be considered in the design of future churches.