

QUANTIFYING AND MITIGATING DECENTRALIZED DECISION  
MAKING IN HUMANITARIAN LOGISTICS SYSTEMS

by

TIMOTHY LUKE MUGGY

B.S., Mathematics, University of Nebraska, 2006

M.S., Operations Research, Kansas State University, 2011

---

AN ABSTRACT OF A DISSERTATION

submitted in partial fulfillment of the  
requirements for the degree

DOCTOR OF PHILOSOPHY

Department of Industrial and Manufacturing Systems Engineering  
College of Engineering

KANSAS STATE UNIVERSITY  
Manhattan, Kansas

2015

# Abstract

Humanitarian and public health logistics systems are often characterized by decentralized decision makers in the form of response agencies who establish supply chains and the beneficiaries who access them. While classical models assume there is a single decision maker with a global objective and authority, decentralized systems consist of multiple decision makers, each with accomplishing his own objective and scope of control. The literature demonstrates that decentralized systems often perform poorly when compared to their hypothetical centralized counterparts. However, there exist few models in the literature to quantify the impact of decentralization and mechanisms for its mitigation are deficient.

This research advances knowledge of decentralized systems through new game theory and optimization models, solution methodologies and theoretical characterizations of system performance. First, the author presents a literature review that synthesizes research regarding the facets of humanitarian operations that can benefit from the application of game theory. The author finds that models of decentralized behavior lack realism, neglecting sources of uncertainty, dynamism and personal preferences that influence individuals' decisions. These findings motivate the remaining components of the thesis.

Next, the author focuses on decentralization on the part of response agencies who open service facilities. Decentralization can adversely impact patient access and equity, both critical factors in humanitarian contexts. A dynamic, robust facility location model is introduced to enable a comparison between a given decentralized response and a hypothetical coordinated response using identical resources. The value of the model is demonstrated through a computational study of the response to a recent cholera epidemic.

Finally, the author introduces game theory models that represent the decisions of beneficiaries seeking relief. The models account for distance, congestion, and the relative importance an individual places on the two. The author constructs an algorithm that computes a decentralized solution in polynomial time. The author quantifies decentralized system performance in comparison to centralized control, bounding the cost of decentralized decision making for the least and most costly outcomes. The author identifies coordination mechanisms encourage centrally optimal decisions within decentralized systems.

QUANTIFYING AND MITIGATING DECENTRALIZED DECISION  
MAKING IN HUMANITARIAN LOGISTICS SYSTEMS

by

Timothy Luke Muggy

B.S. Mathematics, University of Nebraska, Lincoln, 2006

M.S. Operations Research, Kansas State University, 2011

---

A DISSERTATION

submitted in partial fulfillment of the  
requirements for the degree

DOCTOR OF PHILOSOPHY

Industrial and Manufacturing Systems Engineering  
College of Engineering

KANSAS STATE UNIVERSITY  
Manhattan, Kansas

2015

Approved by:

Major Professor  
Jessica L. Heier Stamm, Ph.D.

# Copyright

Timothy Luke Muggy

2015

# Abstract

Humanitarian and public health logistics systems are often characterized by decentralized decision makers in the form of response agencies who establish supply chains and the beneficiaries who access them. While classical models assume there is a single decision maker with a global objective and authority, decentralized systems consist of multiple decision makers, each with accomplishing his own objective and scope of control. The literature demonstrates that decentralized systems often perform poorly when compared to their hypothetical centralized counterparts. However, there exist few models in the literature to quantify the impact of decentralization and mechanisms for its mitigation are deficient.

This research advances knowledge of decentralized systems through new game theory and optimization models, solution methodologies and theoretical characterizations of system performance. First, the author presents a literature review that synthesizes research regarding the facets of humanitarian operations that can benefit from the application of game theory. The author finds that models of decentralized behavior lack realism, neglecting sources of uncertainty, dynamism and personal preferences that influence individuals' decisions. These findings motivate the remaining components of the thesis.

Next, the author focuses on decentralization on the part of response agencies who open service facilities. Decentralization can adversely impact patient access and equity, both critical factors in humanitarian contexts. A dynamic, robust facility location model is introduced to enable a comparison between a given decentralized response and a hypothetical coordinated response using identical resources. The value of the model is demonstrated through a computational study of the response to a recent cholera epidemic.

Finally, the author introduces game theory models that represent the decisions of beneficiaries seeking relief. The models account for distance, congestion, and the relative importance an individual places on the two. The author constructs an algorithm that computes a decentralized solution in polynomial time. The author quantifies decentralized system performance in comparison to centralized control, bounding the cost of decentralized decision making for the least and most costly outcomes. The author identifies coordination mechanisms encourage centrally optimal decisions within decentralized systems.

# Table of Contents

<b>List of Figures</b>	<b>xii</b>
<b>List of Tables</b>	<b>xvi</b>
<b>Acknowledgements</b>	<b>xvi</b>
<b>Dedication</b>	<b>xvii</b>
<b>1 Introduction</b>	<b>1</b>
1.1 Research Motivation . . . . .	2
1.2 Research Contributions and Organization of Thesis . . . . .	3
1.2.1 State of Current Literature . . . . .	4
1.2.2 Agency-level Decentralization . . . . .	5
1.2.3 Beneficiary-level Decentralization . . . . .	6
1.3 Summary . . . . .	8
<b>2 Game Theory Applications in Humanitarian Operations: A Review</b>	<b>9</b>
2.1 Introduction . . . . .	9
2.2 Game Theory Primer . . . . .	11
2.3 Competition between Relief Agencies . . . . .	12
2.3.1 Media Exposure . . . . .	12
2.3.2 Methods of Raising Money . . . . .	14
2.4 Cooperation between and within Relief Agencies . . . . .	17
2.4.1 Opportunities for Cooperation . . . . .	20



2.4.2	Barriers to Cooperation . . . . .	23
2.5	Humanitarian Relief and Governmental Authorities . . . . .	24
2.5.1	Interactions between Governmental and Non-governmental Organiza- tions . . . . .	24
2.5.2	Government Investment in Disaster Defense . . . . .	26
2.6	Models of Individual Beneficiaries . . . . .	27
2.7	Summary of Findings and Directions for Future Research . . . . .	28
2.7.1	Summary . . . . .	28
2.7.2	Research Opportunities . . . . .	29
2.8	Relation to Thesis Objectives . . . . .	37
<b>3</b>	<b>Dynamic, Robust Location Models to Quantify the Impact of Decentral- ization on Service Accessibility</b>	<b>38</b>
3.1	Introduction . . . . .	39
3.2	Background . . . . .	40
3.3	Problem Specification and Methods . . . . .	43
3.3.1	Motivating Context . . . . .	43
3.3.2	Access Metric . . . . .	44
3.3.3	Model Formulation . . . . .	46
3.4	Computational Study . . . . .	54
3.4.1	Context for Study . . . . .	54
3.4.2	Study Design . . . . .	57
3.4.3	The Decentralized Response and the Robust Solution . . . . .	59
3.4.4	Sensitivity Analysis . . . . .	68
3.4.5	Discussion of Results . . . . .	74
3.5	Conclusion and Future Research . . . . .	75

3.6	Connection to the Thesis . . . . .	76
<b>4</b>	<b>Equilibria, Performance Bounds, and Coordination Mechanisms in De-</b>	
	<b>centralized Systems of Beneficiaries</b>	<b>77</b>
4.1	Introduction . . . . .	77
4.2	Background . . . . .	79
4.3	Model and Definitions . . . . .	85
4.4	Analysis of the PFSCWP . . . . .	87
	4.4.1 Bounds on Performance . . . . .	88
	4.4.2 Coordination Mechanisms . . . . .	96
4.5	Analysis of the PSCWP . . . . .	98
	4.5.1 Complexity of Computing an Equilibrium Solution . . . . .	98
	4.5.2 Bounds on Performance . . . . .	101
	4.5.3 Coordination Mechanisms and Effects of Player-Facility Exchanges .	110
4.6	Optimizing Coordination Mechanism Values . . . . .	116
	4.6.1 Minimum Cost Coordination Mechanisms Model . . . . .	116
	4.6.2 Computational Study and Results . . . . .	117
4.7	Conclusion and Future Research . . . . .	130
<b>5</b>	<b>Conclusion and Future Work</b>	<b>133</b>
	<b>Bibliography</b>	<b>137</b>
<b>A</b>	<b>Supplementary Material for Chapter 3: Examples</b>	<b>153</b>
	A.1 An example illustrating the functionality of $f_j^t$ . . . . .	153
	A.2 Clarification of the sufficient access threshold $\phi$ . . . . .	154
<b>B</b>	<b>Supplementary Material for Chapter 4</b>	<b>156</b>

# List of Figures

3.1	A sample planning horizon. . . . .	42
3.2	Three catchment zones capturing demand around facility $j$ , where population location $i = 1$ is in catchment zone 1, $i = 2$ and $i = 4$ are in catchment zone 2, and $i = 3$ is in zone 3. . . . .	44
3.3	CTCs and CTUs available in decentralized response, Nov. 2010–May 2011. . .	56
3.4	Total demand and bed capacity for each month, Nov. 2010–May 2011. . . .	56
3.5	Section boundaries and potential facility locations. . . . .	58
3.6	Maps displaying access in the decentralized response (left), access in the robust solution (center) and demand (right) for November through February; dots indicate open facilities. Access and demand legends are the same those shown in Figure 3.7. . . . .	61
3.7	Maps displaying access in the decentralized response (left), access in the robust solution (center) and demand (right) for March through May; dots indicate open facilities. . . . .	62
3.8	Number of facility location deviations between the decentralized response and the robust solution by month, and total number of facilities opened in the robust solution. . . . .	63
3.9	Percent improvement in average demand-weighted access of the robust solution over the decentralized response in the most unfavorable scenario realization. . . . .	64

3.10	Histogram of access scores in the decentralized response and the robust solution in the most unfavorable scenario, where the x-axis label corresponds to the upper endpoint of access scores for each bin, and the height of the column corresponds to the number of sections with access scores in that bin. . . . .	65
3.11	Access sufficiency in the decentralized response (a) and robust solution (b); dark shading indicates sections with zero access and light shading those with insufficient access in at least one period of the most unfavorable scenario realization. The three sections that received insufficient access at some point in the robust solution are circled. . . . .	67
3.12	Facility location deviations from the base case ( $\delta = 0.35$ ) for experimental values of plan flexibility. . . . .	69
3.13	The number of sections with insufficient access for experimental values of plan flexibility. . . . .	70
3.14	Facility location deviations from the base case ( $m = 3$ ) for experimental values of minimum facility life. . . . .	71
3.15	Average demand-weighted access for experimental values of minimum facility life over time. . . . .	71
3.16	The number of sections with insufficient access for experimental values of minimum facility life. . . . .	72
3.17	Facility location deviations from the base case ( $\gamma = 20$ ) for experimental values of equity emphasis. . . . .	73
3.18	The number of sections with insufficient access for experimental values of equity emphasis. The values for $\gamma = 20$ (base case) and $\gamma = 50$ are identical, overlapping in the graph. . . . .	73
4.1	Categorization of results concerning congestion games. . . . .	84

4.2	The Player-Facility-Specific Congestion Weights Problem (a) and the centralized planner's problem (b). . . . .	87
4.3	Illustration of the network constructed in Theorem 4. . . . .	94
4.4	Illustration of the network described in Theorem 5. . . . .	96
4.5	The transformed network structure with $n$ duplicate arcs from each facility to the sink node. . . . .	100
4.6	Illustration of network described in Theorem 10. . . . .	109
4.7	Illustration of the average daily demand for each section in the Ouest department for April 2011. Dots represent the locations of open facilities within 15km of the Ouest department. . . . .	119
4.8	The average distance traveled (km) to the assigned facility for each section. .	120
4.9	The average congestion experienced (number of people) at the assigned facility for each section. . . . .	121
4.10	The range in optimized congestion weights for each section. . . . .	121
4.11	The average percentage change in congestion weight to obtain equilibrium for each section. . . . .	122
4.12	The average required change in individuals' congestion weights for selected facilities of different types; HCD1 and HCD2 are high-capacity facilities in densely populated areas; LCD1 and LCD2 are two low-capacity facilities in densely populated areas; HCR is a high-capacity facility in a rural area; LCR is a low-capacity facility in a rural area. . . . .	123
4.13	Initial (a) and optimized (b) congestion weights for HCD1; the average change in individuals' congestion weights for this facility (c). . . . .	124
4.14	Initial (a) and optimized (b) congestion weights for HCD2; the average change in individuals' congestion weights for this facility (c). . . . .	125

4.15	Initial (a) and optimized (b) congestion weights for LCD1; the average change in individuals' congestion weights for this facility (c). . . . .	126
4.16	Initial (a) and optimized (b) congestion weights for LCD2; the average change in individuals' congestion weights for this facility (c). . . . .	127
4.17	Initial (a) and optimized (b) congestion weights for a high capacity facility in a rural area; the average change in individuals' congestion weights for this facility (c). . . . .	128
4.18	Initial (a) and optimized (b) congestion weights for low capacity facility in a rural area; the average change in individuals' congestion weights for this facility (c). . . . .	129
A.1	Population and facility locations in Example 2, illustrating sufficient access. .	155

# List of Tables

2.1	Literature on competition. . . . .	13
2.2	Literature on cooperation. . . . .	18
2.3	Summary of literature. . . . .	30
3.1	Number of sections that received insufficient access in the decentralized re- sponse for each month under each scenario. . . . .	66
3.2	Parameter values for the base case and sensitivity analysis. . . . .	68
4.1	Performance bounds for the PFSCWP. . . . .	89
4.2	Performance bounds for the PSCWP. . . . .	102
4.3	Outcomes of the instance described in Theorem 10. . . . .	109

# Acknowledgments

I would like to extend my appreciation to the members of my committee for their time and interest in my academic success. I greatly appreciate your mentorship, your encouragement, and your dedication to academic excellence. I would like to specifically thank my major advisor Dr. Jessica Heier Stamm for the time and energy she has invested in growing me as a scholar and a person. Her level of commitment to students and her passion for her work serve as a shining example for what a professor can and should be. Thank you Dr. Heier Stamm for seeing the best in your students, your consistent encouragement, and the professional development you have provided me.

Thank you to Dr. Todd Easton for keeping your door open and placing students as your number one priority. I can always count on a sincere welcome and an interesting discussion. Your dedication during my master's work was far beyond any reasonable expectation and I cannot thank you enough.

Lastly, I would like to thank my incredible wife Sara for the love, devotion, and friendship she has demonstrated during this long journey. I truly could not have come this far without her, and I am excited to see where our next chapter takes us.

Financial support for this work was provided in part by a Kansas State University Provost's Mentoring Fellowship and by the National Science Foundation under Grant No. CMMI-1228110. Any opinions, findings, conclusions or recommendations are those of the author(s) and do not necessarily reflect the views of the funding organizations.



# Dedication

This dissertation is dedicated to my loving parents Tim and Michelle Muggy for instilling in me a love for learning and to my incredible wife Sara Duhachek Muggy for her consistent love and support.

# Chapter 1

## Introduction

Logisticians in both the commercial and humanitarian sectors design systems to enable the efficient and timely delivery of goods and services. While optimization has long been a fundamental component of commercial supply chain management, the application of operations research to improve the performance of humanitarian supply chains is an emerging and highly active field. This thesis defines humanitarian supply chains as systems that deliver goods and services in response to natural or man-made disasters as well as ongoing public health challenges. Like commercial supply chain systems, common problems in humanitarian supply chains involve inventory management, design of transportation networks, supply and demand forecasts, fleet management, and facility location. However, logisticians in the humanitarian sector face additional complexities and challenges that are imposed by a disaster. Damaged transportation and communication infrastructure, uncertainty in supply and demand, and a dynamic, high-stakes environment provide the setting in which crucial decisions are made. Furthermore, humanitarian environments are characterized by multiple decision makers, including government, non-governmental, private sector, and individual actors, each of which acts according to different objectives.

Quantitative decision models that explicitly account for the uncertain, dynamic context and the impact of multiple decision makers are essential to effective humanitarian logistics

operations. Yet current literature focusing on decisions made at the agency level do not incorporate all of the constraints imposed on a decision maker or the fact that receiving new information may alter previously made plans. Furthermore, literature concerning decisions made by beneficiaries do not consider personal preferences that drive an individual's decision making process. This thesis addresses the knowledge gap through new models and theoretical proofs that quantify the impact of decentralization from both perspectives, and identify mechanisms through which decentralized systems may approach centralized optimality. The remainder of this chapter details the motivation for and contributions of this thesis.

## 1.1 Research Motivation

The primary motivation for the research described in this thesis is the lack of knowledge about the impact of decentralized decision making on the effectiveness of humanitarian operations and of quantitative models that account for it. A system is said to be decentralized when each individual or agency acts according to his own objective, but these decisions impact the system as a whole. This is in contrast to centralized optimization that assumes a single decision maker determines how a system behaves based upon a global objective.

Game theory is a mathematical tool for modeling the decisions of multiple strategic actors. While game theory has proven extremely valuable in modeling interactions within commercial supply chains, its use within the humanitarian sector is relatively new. To demonstrate the usefulness of game theory to humanitarian supply chains, the author introduces the first review of literature that integrates game theoretic concepts and models to humanitarian contexts. The findings of the review motivate the remaining components of this thesis and present alternative avenues for future research.

The first type of decentralized system considered in this research consists of response agencies who assess needs, establish distribution channels, and locate facilities. Decentral-

ization is prevalent in humanitarian logistics systems because sharing information and coordinating operational strategies require valuable time and resources. Moreover, coordination is hindered due to incompatible agency mandates, different languages, and non-standard units of measurement. This lack of coordination among humanitarian logisticians is hypothesized to degrade service accessibility [1, 2, 3], but its impact is not well understood due to a lack of methods for its quantification. Moreover, the methods that exist do not integrate significant realities such as parameter uncertainty and dynamism, which influence the decision making process.

The second type of decentralized system analyzed consists of the individuals who decide when and where to receive service. These individuals are called beneficiaries. Decentralization arises because beneficiaries do not coordinate their decisions, acting independently to optimize their own experiences rather than a system-wide objective. These decisions may result in over-congested facilities and unnecessarily long journeys to receive help. Models in the literature often assume beneficiaries may be assigned to facilities, or that they will simply visit the nearest one. In reality, there is no central authority empowered to direct beneficiaries, and individuals consider factors other than distance.

The objective of this dissertation is to build models based upon mathematical optimization and game theory to quantify the impact of decentralization using metrics of efficiency and equity. Moreover, this research identifies mitigation strategies that enable outcomes to approach centralized optimality within the current decentralized environment.

## **1.2 Research Contributions and Organization of Thesis**

Humanitarian and public health logistics systems are often characterized by decentralized decision makers whose strategies affect the system as a whole. Given the catastrophic consequences of poor operations, policies that mitigate performance degradation due to

decentralization are highly valuable. The author utilizes game theory and mathematical optimization to model two decentralized systems within humanitarian operations: response agencies and beneficiaries. The decisions made by these two groups define the spatial distribution of supply and demand. Effectively matching supply with demand is key to the success of a response. The author seeks to quantify the impact of decentralization and improve the performance of these systems by constructing algorithms and identifying design characteristics that allow decentralized systems to behave in a centrally optimal manner. This research is expected to equip supply chain managers to effectively overcome some of the challenges attributed to decentralization.

### **1.2.1 State of Current Literature**

First, the author presents a literature review that surveys and synthesizes the state-of-the-art with regard to the application of game theory to public health and humanitarian contexts. The review identifies key facets of humanitarian operations that may benefit from game theoretical modeling. The author finds that game theory is most often applied to model competition among non-governmental agencies (NGOs), potential avenues for beneficial coordination, negotiations between government authorities, and the decision making processes of beneficiaries. Specifically, the review makes the following contributions.

- The author discusses competitive models concerning donation management and media exposure. A key finding of the review is that while most literature agrees that competition degrades performance, there are very few suggested mitigation strategies.
- The review suggests several improvements that may be observed through greater inter-agency coordination, but it also identifies significant barriers. The author finds that there have been few contributions that present theoretic models and empirical results of inter-agency coordination.
- The author identifies valuable examples of game theory being applied to model negoti-

ation processes between government authorities and NGOs. However, further research is needed to improve relationships, establish appropriate roles, and improve security and preparedness.

- Models of decentralized beneficiary behavior demonstrate the value of game theoretic models to predict decisions and bound performance metrics but none incorporate individual preferences. The final section of the literature review motivates the research presented in Chapters 3 and 4 of this thesis, focusing on the effects of decentralization among both response agencies and beneficiaries alike. While it is understood that decentralization negatively influences outcomes, the literature lacks models that quantify this impact and prescriptions for its mitigation.
- As the application of game theory to humanitarian operations is an emerging field, the review suggests many avenues for future research including new sources of income for non-profit agencies, models to identify compatible response partners, and suggestions for technology that enables coordination.

### **1.2.2 Agency-level Decentralization**

In Chapter 3, the author analyzes the effect of decentralization on the part of agencies when locating facilities for last-mile service delivery. The objective of the research described in Chapter 3 is to quantify the difference between an actual decentralized response and a hypothetical centralized one. A novel methodology is introduced to model the decisions of a centralized planner, relocating the facilities of a given decentralized response to optimize metrics of efficiency and equity. The centralized model incorporates parameter uncertainty within a dynamic framework to add realism.

The thesis also describes an application of the methodology using data from the cholera epidemic that emerged in Haiti in 2010. The computational results demonstrate that substantially better service may have been provided if location decisions had been coordinated,

underscoring the need for strategies that mitigate decentralization.

The research described in Chapter 3 makes the following contributions.

- The author introduces a centralized benchmark that applies the enhanced two-step floating catchment area method within a dynamic, robust facility location model that computes facility locations to optimize potential spatial accessibility, which is imperative to a high quality of service in humanitarian settings.
- A novel methodology is presented to address spatial fluctuations in demand and minimize disparities in access from one region to another.
- A computational study is performed using data obtained from the Pan American Health Organization, the US Centers for Disease Control and Prevention, and Haiti's Ministry of Public Health and Population regarding a cholera epidemic in Haiti in 2010. Results illustrate the need for coordination among agencies as the centralized solution vastly outperforms the actual decentralized response.
- Sensitivity analysis provides insight regarding which parameters have the greatest impact on efficiency, equity, and robustness.

### **1.2.3 Beneficiary-level Decentralization**

In Chapter 4, the author applies game theory to model systems of beneficiaries deciding where to seek treatment from a set of open service facilities. The author introduces two classes of network congestion games: the player-specific congestion weights problem (PSCWP) and the player-facility-specific congestion weights problem (PFSCWP). In both games, each player chooses a facility to optimize the utility he derives from distance traveled and congestion experienced. The differences between the two problems are the factors the individual considers in measuring the relative utility of distance and congestion.

Integral to the analysis is the concept of pure Nash equilibrium (NE), which is an outcome of a game in which no player can improve his utility by choosing a different facility. While

equilibrium solutions represent decentralized outcomes that result from individual decisions, a metric of system performance from a global perspective is also required. To address this need, a centralized planner's problem is represented using an optimization model that assigns each beneficiary to one facility while minimizing the total congestion and distance. The centralized planner does not consider the weight an individual places on congestion, but instead focuses on what is best for the whole system.

The impact of decentralization is measured by comparing the centralized objective function value of equilibria to a centrally optimal solution. The price of stability (PS) is the ratio of the centralized costs of the least expensive equilibrium and the centralized optimum. Conversely, the price of anarchy (PA) is the ratio of the centralized costs of the most expensive equilibrium to centralized optimum. The author proves bounds on each of these metrics for both the PSCWP and the PFSCWP.

Finally, the author identifies coordination mechanisms that align what is best for the individual with what is best for the system, encouraging decentralized behavior to approach a centralized optimum. Specifically, the research finds modifications to player utility functions under which a centralized optimum is also an equilibrium.

The specific contributions of Chapter 4 are as follows.

- The author defines two new classes of games denoted PSCWP and PFSCWP, to model beneficiaries choosing the facility at which to receive service. Both classes consider individual objectives based on key factors such as distance and congestion, incorporating the relative emphasis an individual places on the two.
- A polynomial-time algorithm is constructed to compute equilibrium solutions for the PSCWP, allowing efficient predictions of beneficiary behavior.
- The author provides new theoretical bounds on the prices of anarchy and stability for the PSCWP and the PFSCWP. Specifically, the author shows that both measures may be arbitrarily high, but depend on the greatest and least weight placed on congestion



over the set of players.

- This research identifies coordination mechanisms that encourage decentralized decisions to reflect what is best for the whole system. The author demonstrates that when each player places exactly twice as much weight on congestion as he does on distance, a central optimum is also an equilibrium. Moreover, solutions are characterized for which there exists congestion weights that, when applied to player utility functions, make the centralized optimum an equilibrium.
- The author shows that any solution to the PFSCWP, including the centralized optimum, may be transformed into an equilibrium whether congestion weights are restricted to non-negative or non-positive values.
- An efficient methodology consisting of two optimization models is introduced to find coordination mechanisms in practice. The first model computes an assignment of beneficiaries to facilities that minimizes the total distance traveled and congestion. The second model identifies congestion weights under which the centralized optimum is also an equilibrium.
- The methodology is demonstrated through a computational study that utilizes data from the cholera epidemic in Haiti, specifically focusing on the area surrounding the capital city of Port-au-Prince.

### **1.3 Summary**

The combined contributions of this thesis further the understanding of decentralized systems, particularly those found in humanitarian operations. In addition to filling important theoretical gaps in the literature, the thesis demonstrates practical applications for the methods and concepts presented. In Chapter 5, the author identifies avenues for future research.

# Chapter 2

## Game Theory Applications in Humanitarian Operations: A Review

This component of the thesis surveys the current applications of game theory to humanitarian contexts and identifies an important gap, motivating the primary contributions of this thesis. Specifically, the author finds that while game theoretic models of agency and beneficiary behavior exist, the understanding of how the resulting decentralization impacts a response is still lacking. This chapter was published in the *Journal of Humanitarian Logistics and Supply Chain Management* [4].

### 2.1 Introduction

Scholarly literature well documents the complexities faced by humanitarian logisticians [5, 6, 7, 8]. Like their commercial sector counterparts, humanitarian supply chains are designed to deliver the correct quantity of goods to the right place at the right time. However, humanitarian supply chains encounter additional challenges, including damaged transportation and communication infrastructure in unstable or even hostile environments [9]. This makes obtaining accurate information difficult in circumstances that require quick, decisive

action [10]. The resulting uncertainties and propensity for disruption greatly complicate decision making processes. Another obstacle to successful disaster response is the decentralized nature of humanitarian operations. Multiple agencies are engaged in humanitarian response, and each makes decisions about supply chain functions according to its own objectives and available information. Urgency, in addition to incompatible languages, information technology tools, and data standards, inhibits agency collaboration [10]. Decentralization is a great challenge in disaster response because independent decisions of non-governmental organizations (NGOs), governments and military entities, and beneficiaries impact relief outcomes for the whole system.

Game theory is a powerful tool for modeling the interactions of independent decision makers, including the stakeholders in humanitarian supply chain systems. A branch of mathematics long used in economics and political science to model human interaction, game theory has also been applied to commercial supply chains to maximize value [11], optimize cooperative efforts [12], and form marketing strategy [13], all of which are also relevant in humanitarian operations. Game theory models decentralized decision makers as players in a game, each of whom makes decisions according to the game's structure and his own goal. The game's outcome represents the results of interactions between decision makers.

Although applications of game theory to commercial supply chain settings are increasing, its use as a tool to analyze and improve humanitarian supply chains is limited to date. This component of the thesis surveys existing literature that illustrates ways in which game theory has been and can be utilized within humanitarian relief operations. As this is an emerging field, we draw broadly from literature in operations research, humanitarian logistics, and political and management sciences. The contributions of this chapter are two-fold. We first document the facets of humanitarian operations to which game theory has been applied in a comprehensive summary of relevant literature. Secondly, we identify opportunities for future research in the field. We begin with a brief overview of game theory. In chapter 2.3 and chapter 2.4, we present literature on competition and cooperation, respectively, between

NGOs. Next, chapter 2.5 discusses game theoretic models that integrate the decisions of government authorities, while chapter 2.6 describes models of beneficiary decision making. In chapter 4.7, we synthesize our findings and suggest avenues for future research.

## 2.2 Game Theory Primer

A game theory model, or simply a ‘game’, consists of several elements. The first is a set of players, each with a set of strategies from which to choose. Each player also maintains a goal, often expressed mathematically as a utility function to optimize. The combination of strategies chosen by all players determines the outcome of the game and the consequences, or payoff, to each player according to his utility function. In a game theory model of humanitarian operations, players represent stakeholders or decision makers, such as NGOs, government agencies, donors, or beneficiaries. Examples of payoffs in this context include minimized costs, efficient delivery of services, accurate demand estimation, number of beneficiaries reached, funds raised, and the level of public awareness created.

Game theory models are classified along several dimensions. In simultaneous (or static) games, all players make a decision at the same time, while extensive (also sequential or dynamic) games involve a sequence of decisions where some players observe the actions of others before deciding upon their own. A game is symmetric if the same set of strategies is available to each player and each player’s payoff depends only on the combination of strategies played, not on the identities of those playing them. Otherwise, a game is asymmetric. Games of perfect information are those in which each player knows the actions available to other players, their payoff functions, and any decisions that have already been made. If players are not perfectly informed about these characteristics, the game is one of imperfect information. Games may be classified according to payoffs, where zero-sum games are those in which anything gained by one player or set of players is lost by another so that the net payoff to all the players is zero. Non-zero-sum games allow general payoff amounts. Fi-

nally, games may be non-cooperative or cooperative. In non-cooperative games, each player chooses actions independently to optimize her own payoffs. Cooperative game models represent the actions of groups of players in which cooperation may yield strategic alliances and improved payoffs. The reader is referred to [14] and Gibbons [15] for comprehensive treatment of different classes of games.

Integral to an understanding of game theory is the concept of Nash equilibrium [16], which is an outcome from which no player can improve his payoff by unilaterally altering his strategy. In other words, no player has incentive to deviate from his strategy even upon observing the strategies of his opponents. Nash equilibria do not necessarily imply optimal payoffs for any player. Instead, they represent the product of decisions made in a player's self-interest and the assumption that other players will do likewise.

## 2.3 Competition between Relief Agencies

Non-profit activity has risen sharply over the past century; for instance, the number of registered US non-profit organizations rose from 12,000 in 1940 [17] to more than 1.5 million in 2012 [18]. In this setting, competition may emerge between NGOs for media exposure and funds. This section describes game theory models of inter-agency competition. Figure 1 summarizes the topics addressed by each of the papers we survey. While all of the publications identify sources of competition and most discuss negative outcomes that can result, only two sources give specific advice to mitigate these outcomes.

### 2.3.1 Media Exposure

Media presence can cause competition between NGOs as it provides an opportunity to publicize a group and its cause. Research shows that donors are more likely to give to charities they have seen first-hand [19] or to those perceived to be productive [17]. Therefore, media coverage attracts support [20] and encourages competition among agencies for service

**Table 2.1:** *Literature on competition.*

<b>Author</b>	<b>Publication</b>	<b>Sources of Competition</b>	<b>Effects of Competition</b>	<b>Mitigating Effects of Competition</b>
Castaneda et al. (2008)	The Journal of Law, Economics and Organization	X	X	X
Feigenbaum (1987)	The Journal of Industrial Economics	X	X	
Frumkin and Kim (2001)	Public Administration Review	X	X	
McCardle et al. (2009)	Decision Analysis	X		
Privett and Erhun (2011)	Manufacturing and Service Operations Management	X	X	X
Tatham and Kovács (2010)	International Journal of Production Economics	X	X	
Wardell (2009)	Ph.D. Dissertation - Georgia Institute of Technology	X	X	
Zhuang et al. (2011a)	Annals of Operations Research	X		
	Totals	8	6	2

areas with a media presence [9]. The media can also be used to “signal” current donors that their money is being well spent in hopes of soliciting future donations [21]. This trend has attracted criticism from researchers who argue too much emphasis on media exposure degrades the quality of service. Wardell (2009) introduces a symmetric game

theory model to demonstrate the impact of agencies' desire to signal donors while choosing aid distribution site locations. Each agency's strategy is based upon an objective function combining beneficiary impact and signaling potential. The result of the game is the over-saturation of relief areas in which media coverage is high to the detriment of service in other areas. Wardell asserts that over-saturation wastes resources that would better serve beneficiaries in a different location.

### **2.3.2 Methods of Raising Money**

In between disasters, NGOs are responsible for supporting themselves financially through donations and grants. In fact, nearly 300 billion dollars are given to charity within the United States each year and nine out of ten people report giving to a charitable organization [22]. NGOs of similar geographic location and/or sector compete with each other for this money because they share the same donor pool. Increasing competition encourages more of an agency's money to be diverted from charitable goals to fundraising efforts [23]. Fundraising carries upfront costs and relies on public empathy for a cause, which fluctuates over time [17]. This section discusses two game-based fundraising strategies utilized by NGOs to raise money. The first system involves the intentional public disclosure of information concerning an NGO's performance and impact. The second type of system rewards donors for their gifts in hopes of capitalizing upon a donor's desire for public acknowledgment.

#### *Information Disclosure*

One fundraising tool available to NGOs is the public disclosure of information. The information released by an NGO regarding donations, spending, active projects, and perceived impact is intended to demonstrate its efficiency and effectiveness in comparison to others, resulting in a strategically advantageous public perception. Supply chain decisions directly impact information on money spent and beneficiaries reached, and thus form an

important part of the data that agencies have available to disclose. Important questions are how much and what kind of information should be shared. Many donors want to see where money is being spent to understand the relative impact of their donations [24], but donors may become confused or frustrated by too much information [22]. There is also the danger of disclosing details about efficient operations to competitors who will replicate them [17].

An objective of the NGO is to maximize donations, but the literature describes several different objectives for donors. These include a desire to feel good about themselves, dubbed the “warm glow” effect [25], or to demonstrate their wealth to others [26]. Zhuang et al. [22] posit that people also give because they empathize with a problem and want their donation to maximize service to beneficiaries. They construct an extensive game model between a group of donors and a group of charities to analyze the relationship between information disclosure and charitable donations. The model assumes that donors desire some quantifiable combination of personal publicity and charitable impact from their donation while the charitable organization desires the maximum amount of gifts possible. Experimentation with this game shows a positive correlation between charitable giving and relevant information disclosure. The question of what type of information to disclose is studied by Frumkin and Kim [17], who analyze charity donations over a ten-year period. Interestingly, the results indicate that charities reporting high financial efficiency did not receive significantly more donations than those who did not. The authors suggest that invoking empathy and demonstrating ability to have an impact may be more beneficial than disclosing information about leanness.

### *Fundraising Structures*

An organization’s fundraising structure can also impact its success in competing for donations. One structure is tiered giving, in which organizations assign donations to different tiers corresponding to their amount and donors may receive a tier-specific reward. Mc-



Cardle et al. [27] argue that this type of system is superior to non-tiered systems using a single-donor model. The players are a charity, which chooses tier levels, and a donor, who chooses a gift amount based upon an objective function that includes warm glow and public acknowledgement. They find that a donor will never decrease his donation when a tiered system is implemented, and that if the next highest tier is sufficiently close, a donor will increase his donation to that tier. The authors construct a tool for charities to identify tier levels that maximize one-time donations given the estimated wealth distribution of their target market.

Various contract structures for non-profit fundraising have also been modeled using game theory. Castaneda et al. [24] argue for contracting with donors to stabilize an organization's income. They model competition for donations as a three-stage dynamic game between charitable organizations and potential donors. An equilibrium analysis of this model concludes that as charities increase the proportion of expenses paid with donor contracts, less money is put toward promotion and administration expenses, leaving more for charitable goals.

Privett and Erhun [28] propose contracts that permit donors to audit a non-profit's use of their funds. If tangible benchmarks specified in the donation contract are not achieved, the charity may be charged a penalty that reverts to the donor. The authors apply the principal-agent framework to this scenario. Principal-agent games are extensive games of imperfect information in which the first player (the principal) offers terms to encourage one or more agents to act in the principal's best interest. (See Ross [29] for an early introduction and Zenios [30] for an overview of supply chain applications.) In this application, the donor is the principal and the charitable organizations are the agents; each player seeks to maximize his respective utility function. Results indicate that donors and non-profits that report good administrative and operational efficiency would welcome an auditing framework. The authors suggest that auditing would increase efficiency because managers would try to avoid the penalty for poor performance. In contrast, researchers have identified instances where contracts may degrade the quality of service in a disaster response [31]. Such is the case

when an immediate need presents itself but the only available resources have been contracted for other purposes.

## 2.4 Cooperation between and within Relief Agencies

Though competition exists between NGOs, the altruistic nature of humanitarian relief attracts personnel with common goals who are willing to work together [32]. The commercial supply chain literature suggests numerous advantages of cooperation between agents (see Arshinder et al. [33] and Cachon and Netessine [34] for reviews), many of which also have parallels in the humanitarian context. As shown in Figure 2, the literature contains numerous articles that describe motivations for inter-agency and intra-agency cooperation, the most obvious of which is the positive effect it may have on beneficiaries [35]. Partnering NGOs may identify service gaps by comparing their respective locations, resources, and limitations. Furthermore, partnering agencies are able to focus on core competencies [36, 37], capitalize on economies of scale in purchasing and transportation [38], and utilize shared warehouse space for pre-positioned goods [37]. Cooperating NGOs may also reduce costs by consolidating administration, standardizing measurements, and adopting common policies [37].

This section discusses NGO cooperation from a game theoretic perspective. Though agency cooperation is especially beneficial in the humanitarian sector, its mathematical study is relatively new. Here we describe models that emphasize specific opportunities for cooperative efforts and then discuss obstacles to cooperation in practice. In total, we survey 20 articles concerning cooperation; the topics addressed by each article are summarized in Figure 2. While most articles propose reasons for and/or barriers to cooperation, it is encouraging to note that 77 percent of those that discuss obstacles also suggest methods to improve cooperation.

**Table 2.2:** *Literature on cooperation.*

<b>Author</b>	<b>Publication</b>	<b>Motivations</b>	<b>Barriers</b>	<b>Methods for Improvement</b>
Bagchi et al. (2011)	International Journal of Production Economics	X	X	X
Balcik et al. (2010)	International Journal of Production Economics	X	X	X
Coles and Zhuang (2011)	Journal of Homeland Security and Emergency Management	X	X	X
Coles and Zhuang (2013)	Working paper		X	X
Coles et al. (2012)	Socio-Economic Planning Sciences	X		
Cruijssen et al. (2007)	Transportation Research Part E: Logistics and Transportation Review	X	X	X
Ergun et al. (2013)	Production and Operations Management	X		X
Hasija (2012)	Proc. of 23rd Annual POMS Conference	X	X	X
Heier Stamm et al. (2013)	Working paper	X		X

<b>Author</b>	<b>Publication</b>	<b>Motivations</b>	<b>Barriers</b>	<b>Methods for Improvement</b>
McLachlin and Larson (2011)	Journal of Humanitarian Logistics and Supply Chain Management	X	X	X
Moore and Heier Stamm (2012)	Proc. of 2012 Industrial and Systems Engineering Research Conference	X		X
Natsios (1995)	Third World Quarterly		X	
Overstreet et al. (2011)	Journal of Humanitarian Logistics and Supply Chain Management		X	
Proaño et al. (2012)	Omega	X	X	X
Schulz and Blecken (2010)	International Journal of Physical Distribution and Logistics Management	X	X	X
Stewart et al. (2009)	International Journal of Physical Distribution and Logistics Management	X		X
Tatham and Kovács (2010)	International Journal of Production Economics	X	X	X
Thevenaz and Resodihardjo (2010)	International Journal of Production Economics		X	

<b>Author</b>	<b>Publication</b>	<b>Motivations</b>	<b>Barriers</b>	<b>Methods for Improvement</b>
Trestrail et al. (2009)	International Journal of Physical Distribution and Logistics Management	X		X
Zhuang et al. (2011b)	Proc. of 2011 NSF Engineering Research and Innovation Conference	X		X
	Totals	16	13	16

### 2.4.1 Opportunities for Cooperation

For humanitarian logisticians, cooperative models identify methods for partnering agencies to achieve greater impact than what is possible when operating independently. Prior research also investigates conditions under which inter-agency cooperation would be welcomed by supply chain players and introduces intra-agency cooperative practices to improve operations.

Procuring supplies and transportation services often involves interactions between multiple humanitarian supply chain parties [39, 40]. For example, the US Department of Agriculture (USDA) utilizes a bidding process in which domestic suppliers of international food aid and ocean carriers submit separate bids for their services. Upon receiving both sets of bids, USDA uses a linear program to select the lowest cost supplier-carrier pairings to transport procured food. The current system is argued to motivate bids that are much higher than actual costs, decreasing the amount of food aid that USDA is able to purchase [39]. Trestrail et al. [41] recommend the adoption of a uniform price auction, an approach shown to keep winning bids closer to actual costs. If USDA implements the new system, Bagchi et al. suggest that synergetic suppliers and carriers form partnerships with each other a priori, leading to lower joint bids that reflect the benefits of cooperation. Savings from lower bids

could increase the amount of food aid that USDA can send to beneficiaries.

Another example of the potential for increased impact through cooperation is documented by Moore and Heier Stamm [2], who quantify the impact of the absence of coordinated facility location decisions on cholera treatment accessibility in Haiti. Optimal treatment facility locations are identified using an integer programming model that maximizes access. The results indicate that coordinated facility location decisions may have led to significant improvements in treatment accessibility in comparison to actual decisions made by NGOs acting independently. To close this gap, the authors propose future work in a cooperative game framework to identify mechanisms that lead to independent decisions that optimize access to beneficiaries.

Research by Ergun et al. [42] and Proaño et al.[43] emphasizes conditions under which multi-agency cooperation is beneficial and acceptable to the organizations involved. Motivated by a successful partnership between the United Parcel Service (UPS) and The Salvation Army in Haiti that led to improved operations in a camp for internally displaced persons, Ergun et al. [42] introduce a cooperative game theory model to analyze technology-enabled coordination among agencies. The players are camp management agencies, each of which must decide whether to adopt an electronic registration system and collaborate with other camps. Since adoption requires a significant investment, agencies' choices depend on how the costs are allocated among them. The authors identify conditions under which there exists a cost allocation mechanism that incentivizes all agencies to collaborate. Proaño et al. [43] study beneficiary access to vaccines as a game between vaccine manufacturers and purchasing countries. The model produces vaccine prices that maximize manufacturer profits while meeting vaccine demand. To combat unfair outcomes, the researchers suggest that a third player, such as the World Health Organization, the Pan American Health Organization, or the United Nations Children's Fund, use the model to negotiate fair prices with vaccine producers. In this instance, vaccine manufacturers may experience lower net profit, but if they share the objective to maximize vaccination coverage, cooperation may produce

beneficial solutions for all.

Within a single agency, separate divisions and country offices may have different incentives and objectives, making supply chain coordination across the agency difficult. One approach is to adopt a centralized system, in which a single decision maker or group controls supply chain operations. Such systems have the advantage of standardized practices and can consider what is best for the whole system. Unfortunately, some have performed sluggishly in disaster response. For instance, the International Federation of Red Cross and Red Crescent Societies (IFRC) formerly utilized a centralized supply chain based out of their headquarters in Geneva, Switzerland. When Hurricane Mitch struck Honduras in 1998, IFRC initiated relief operations no less than two weeks following the disaster, long after other agencies had established themselves. The delay was blamed on an inefficient aid request process in which information had to navigate several channels to reach the centralized decision maker [44].

In contrast to the centralized approach, decentralized systems rely upon multiple decision makers, each controlling smaller amounts of resources within a subsystem. Decentralized systems benefit from strategies better suited to local conditions since decision makers are closer to affected populations [3]. IFRC, for example, restructured its supply chain in 2005 and adopted a decentralized system that split global operations into three Regional Logistics Units, each with its own headquarters and prepositioned goods. The perceived advantages of the new system included faster response time, better communication of needs, and local expertise. The new supply chain was tested after the 2006 earthquake in Yogyakarta, Indonesia. The response was much faster and economical than past efforts. In general, coordination problems can become significant when local decision makers lack global information or visibility regarding the effect of their decisions on the system as a whole. This may result in duplicated work and misallocation of resources [3]. Regardless of the level of decentralization, coordination of efforts is essential within an agency's supply chain to maximize performance.

## 2.4.2 Barriers to Cooperation

Given the potential benefits, what is stopping improved cooperation between NGOs? The initial barriers often result directly from the nature of disaster relief. The urgency of many response environments hinders an agency's ability to coordinate with others as it requires valuable time and human resources [9]. Damage to communication and transportation infrastructure compounds the problem by inhibiting coordination when partnerships do form [10].

As a response stabilizes, agencies have difficulty finding partners with compatible objectives, practices, and resources [38]. NGOs often utilize distinct systems for managing their resources and handling data [9, 45], which results in software incompatibility [8] and varying units of measurement [9]. Zhuang et al. [46] and Coles et al. [47] explore the partnerships that emerged in response to the 2010 Haiti earthquake. Interestingly, data indicate that the most effective partnerships were based on new contacts rather than previously existing relationships with local agencies. In this response, NGOs actively compared alternatives when selecting local partners with compatible objectives [48]. This research underscores the importance of NGOs seeking optimal partnerships and enduring the necessary relationship-building required. Game theory can be used to identify a beneficial partnership, as in Coles and Zhuang [47], who construct an extensive game that models behavior between two agencies deciding to collaborate or not. The model integrates a probability that any two agencies will be compatible, every partnership is assumed to require an initial investment, and successful partnerships yield a greater benefit than cost. The authors propose extending the model to  $n$  players, enabling compatible partnership formation on a larger scale.

Issues of trust and power also present barriers to cooperation. The competitive nature of humanitarian relief can hinder trust formation between NGOs [37, 45, 49]. Upon a conscious decision to combine efforts, agencies may suffer hierarchal power disputes [9, 50]. Small agencies may fear losing their sovereign identity upon partnering with a large agency that may receive the bulk of visibility and credit, as well as being pushed out of the partnership



once their resources are no longer necessary [38].

## **2.5 Humanitarian Relief and Governmental Authorities**

Government and military entities participate in and impact many humanitarian operations. Two of the most frequent humanitarian contexts in which governmental and non-governmental organizations interact are in cases of population displacement across borders and in settings where both NGO and military groups operate. Game theory provides tools to model the interactions between governmental and non-governmental decision makers, who may have conflicting objectives. Games are also used to model government investments in disaster defense.

### **2.5.1 Interactions between Governmental and Non-governmental Organizations**

Natural and manmade disasters often force refugees to seek shelter across proximal borders. Governmental authorities retain the power to open and close borders to refugees and relief agencies alike. Prospective host governments often request support from the United Nations High Commissioner for Refugees (UNHCR), the North Atlantic Treaty Organization (NATO), and other countries to assist arriving refugees. Games are useful in investigating motives, explaining decisions, and predicting outcomes of these interactions. Generally players include a country of asylum, a country of repatriation, and a group of refugees or their representative (NATO or UNHCR).

Researchers have chosen the Theory of Moves (TOM) to model many such circumstances. Originally defined by Brams [51] and revised by Wilson [52], TOM is an extensive game framework with perfect information in which players sequentially make changes in

strategy until all players decide to pass, at which point the game is at equilibrium. This process mirrors lengthy political negotiations in which agents make offers and counter-offers. TOM has been utilized to model the situations faced by Rwandan, Indochinese, and Albanian refugees, in particular. The primary contribution of the Rwandan model [53] is its examination of sympathetic versus non-sympathetic countries of asylum, where the level of sympathy is reflected in a country's utility function and depends on economic and cultural compatibility. The results of the paper indicate that varying levels of sympathy may alter a government's decision to help or not. The same author uses TOM to model the plight of Indochinese refugees immediately following the Vietnam War [54]. The players in the game include Thailand and the US; Thailand's actions are to permit or deny asylum, while those of the US are to permit or deny resettlement. In actual negotiations, Thailand threatened to refuse asylum unless the US offered resettlement. Zeager's analysis demonstrates the impact of one player's power to end the game at a mutually disadvantageous outcome and the ways that TOM can provide insight about this threat power.

Comparing actual outcomes with those predicted by game theory models points to ways in which modeling approaches can be improved for future applications. Williams and Zeager [55] model the 1998 crossing of ethnic Albanian refugees from Kosovo into Macedonia as a game between Macedonia and NATO. Macedonia's available actions are to open or close its borders, while NATO decides whether to commit only financial assistance or to provide asylum assistance as well. The equilibrium solution, in which NATO provides only financial assistance and Macedonia keeps its borders closed, is the worst possible outcome. The actual outcome, in which NATO also provided asylum assistance and Macedonia opened its borders, differed from the one predicted by the model due to the influence of third parties not explicitly represented in the game, including UNHCR, journalists, and the US Department of State.

NGOs frequently interact with militaries of both host country and foreign governments. Countries may commit military resources to ensure security or execute humanitarian supply

chain functions. NGOs and military units sometimes participate in the same missions, wear the same clothing, and drive the same vehicles, making humanitarian personnel indistinguishable from soldiers [56]. Furthermore, some NGOs actively utilize military resources because military groups are known for being organized, well trained, and able to command extensive supply networks. In some cases, coordinated operations between NGOs and military forces may reach more people. Host governments, for instance, are often the first responders to disasters within their borders [57]. Military forces add a level of complexity to humanitarian environments because, while a partnering NGO may achieve greater effectiveness by utilizing military resources, the partnership may negatively impact public perception of the NGO's neutrality. IFRC realized this during humanitarian operations in Pakistan after an earthquake in 2005. Despite having access to over 100 military helicopters to transport aid, IFRC chose to hire their own aircraft at greater expense to avoid conflict with their principles of humanity, independence, and neutrality, especially in the politically tense region [57]. In such circumstances, decision models offer the ability to evaluate tradeoffs between conflicting objectives such as cost and neutrality.

## 2.5.2 Government Investment in Disaster Defense

Nations have a vested interest in preparing for and mitigating the impact of disasters. Much research has applied game theory to questions of defense against disasters caused by acts of terrorism; these models fall into a class called attacker-defender games (see Brown et. al. [58], for an introduction). One paper in this stream of literature simultaneously considers investments in defense against terrorism and natural disasters. Zhuang and Bier [59] model a defender preparing for an unknown attack that may originate either from terrorists who have knowledge of the system or from a natural disaster of random force and location. The defender chooses the proportion of his budget to invest in protection from these two types of events. An equilibrium solution is the budget allocation that makes both attacker and defender indifferent to the type, location, and strength of an attack.

While the model was designed for use in protecting a set of targets, it could be extended for humanitarian supply chain managers who wish to adapt a defensive perspective. Disruptions to humanitarian supply chains carry a much higher penalty than their commercial counterparts because lives may literally hang in the balance [60]. Game theory can be applied to guide decisions about investments in security and stability and allow supply chain managers to prepare for natural and man-made disruptions.

## 2.6 Models of Individual Beneficiaries

Most models in the literature capture decisions by governmental or non-governmental organizations. Beneficiaries also act according to individual objectives and available information, and their choices impact humanitarian supply chain operations and public health campaign outcomes. For instance, beneficiaries commonly must choose which facility to visit for services or relief supplies. Classic models of facility location and resource allocation rely upon the assumption that consumers are either assigned to a facility or that they will visit the closest one [61, 62]. In reality, centralized assignment is often not possible, and beneficiaries may consider factors besides distance. Game theory models that explicitly capture beneficiary decisions demonstrate the impact that decentralization can have on system outcomes [1, 63]. If supply chain managers begin integrating results from decentralized models, they may more accurately predict beneficiary decisions, improving aid utilization and beneficiary access.

Individuals' choices about health, such as whether or not to be vaccinated against an infectious disease, can also impact their community at large. Vaccination confers a direct benefit to those vaccinated, but as more people receive vaccinations, those who remain unvaccinated indirectly benefit from the lower probability of being infected. Shim et al. [64] model a community of individuals, each deciding whether to vaccinate himself against influenza or not. The outcomes emphasize the dramatic difference in vaccination levels that

emerge when decision makers are completely self-interested and when levels of altruism are introduced to an individual’s objective function. This research demonstrates the potential for models to help identify opportunities to influence individual utility functions in a way that improves human outcomes.

## **2.7 Summary of Findings and Directions for Future Research**

This component of the thesis summarizes literature that applies game theory to humanitarian operations. The interactions of independent decision makers within this sector provide an ideal setting for the application of game theory to optimize strategy and improve operations. The primary finding is that while there have been promising steps toward an integration of game theoretic concepts, the humanitarian relief community has access to only a few practical tools. The enormous consequences of supply chain performance in the humanitarian sector further strengthen the argument for its mathematical study. Because there has not been a literature review of game theory’s application to humanitarian supply chains, this work serves as a reference of current literature while discussing directions for future research.

### **2.7.1 Summary**

To identify gaps in existing research, we categorize each article according to the facet(s) of humanitarian response to which it corresponds, as summarized in Figure 3. If the contribution describes a game theory model, we denote that in the “Game Model” column. Since decentralization in humanitarian environments makes game theory a particularly important tool, we also denote papers that explicitly discuss decentralization. The “Supply Chain Operations” category includes 40 percent of the papers; these papers deal with the physical

distribution of aid. Papers indicated in the “Planning and Strategy” column constitute 37.1 percent of those surveyed. These address topics that affect an NGO in the preparedness phase of disaster response, including methods for improving efficiency and security as well as identifying potential political actions. Lastly, the category labeled “Administration and Donations” refers to the 28.6 percent of papers we survey that provide insight for supply chain managers about administrative functions and soliciting donations.

Of the 35 articles listed in Figure 3, 18 include an explicitly modeled game. This supports the claim that, while there are opportunities for game theory to be applied to humanitarian logistics, few existing studies have done so. This becomes even clearer when one considers that 40 percent of all the papers we survey focus on supply chain operations that can benefit from game theoretic analysis, yet only 16.6 percent of the papers that include game theory models address this aspect. Planning and strategy papers constitute 44.4 percent of those with models, while sources emphasizing administration and donations contribute 33.3 percent. Decentralization is the focus of 16.6 percent of those papers that include games. Among the major game theory model categories, extensive form games are well-represented in the current literature. These are used to represent interactions between charities and donors, the formation of partnerships between NGOs, bidding by suppliers and carriers, negotiation processes, and attacker-defender scenarios.

## **2.7.2 Research Opportunities**

We see important opportunities for increased use of game theory models in humanitarian operations in general and, in particular, for studies applying cooperative and imperfect information games. In addition to these broad observations, we describe a number of specific opportunities for game theory models to provide insight to humanitarian operations.

Disasters often damage communication networks, making reliable information difficult to obtain. However, a successful response relies upon accurate information about demand, supply, and available transportation routes. Generally, NGOs do not allocate substantial

**Table 2.3:** *Summary of literature.*

<b>Author</b>	<b>Publication</b>	<b>Game Model</b>	<b>Centralized vs. Decentralized</b>	<b>Operations</b>	<b>Planning and Strategy</b>	<b>Donations</b>
Andreoni (1990)	The Economic Journal					X
Bagchi et al. (2011)	International Journal of Production Economics	X			X	
Balcik et al. (2008)	Journal of Intelligent Transportation Systems			X		
Balcik et al. (2010)	International Journal of Production Economics			X	X	
Besiou (2012)	Proc. of 23rd Annual POMS Conference		X			X
Brams (1994)	American Scientist	X			X	
Castaneda et al. (2008)	The Journal of Law, Economics & Organization	X				X

<b>Author</b>	<b>Publication</b>	<b>Game Model</b>	<b>Centralized vs. Decentralized</b>	<b>Operations</b>	<b>Planning and Strategy</b>	<b>Donations</b>
Coles and Zhuang (2011)	Journal of Homeland Security and Emergency Management			X		
Coles and Zhuang (2013)	Working paper	X			X	
Coles et al. (2012)	Socio-Economic Planning Sciences			X		
Ergun et al. (2013)	Production and Operations Management	X		X		
Feigenbaum (1987)	The Journal of Industrial Economics					X
Frumkin and Kim (2001)	Public Administration Review					X
Gatignon et al. (2010)	International Journal of Production Economics		X	X		
Glazer and Konrad (1996)	The American Economic Review	X				X



Author	Publication	Game Model	Centralized vs. Decentralized	Operations	Planning and Strategy	Donations
Hasija (2012)	Proc. of 23rd Annual POMS Conference		X	X		
Heier Stamm (2010)	Ph.D. Dissertation Georgia Institute of Technology	X	X	X		
Heier Stamm et al. (2013)	Working paper	X	X			
McCardle et al. (2009)	Decision Analysis	X				X
McLachlin and Larson (2011)	Journal of Humanitarian Logistics and Supply Chain Management				X	
Moore and Heier Stamm (2012)	Proc. of 2012 Industrial and Systems Engineering Research Conference	X	X	X		
Natsios (1995)	Third World Quarterly			X		

Author	Publication	Game Model	Centralized vs. Decentralized	Operations	Planning and Strategy	Donations
Overstreet et al. (2011)	Journal of Humanitarian Logistics and Supply Chain Management			X		
Privett and Erhun (2011)	Manufacturing and Service Operations Management	X				X
Proaño et al. (2012)	Omega	X			X	
Stewart et al. (2009)	International Journal of Physical Distribution and Logistics Management				X	
Tatham and Kovács (2010)	International Journal of Production Economics			X		
Thevenaz and Resodihardjo (2010)	International Journal of Production Economics		X	X		
Wardell (2009)	Ph.D. Dissertation Georgia Institute of Technology	X				X

<b>Author</b>	<b>Publication</b>	<b>Game Model</b>	<b>Centralized vs. Decentralized</b>	<b>Operations</b>	<b>Planning and Strategy</b>	<b>Donations</b>
Williams and Zeager (2004)	Conflict Management and Peace Science	X			X	
Zeager (1998)	International Studies Quarterly	X			X	
Zeager (2002)	Rationality and Society	X			X	
Zhuang and Bier(2007)	Operations Research	X			X	
Zhuang et al. (2011a)	Annals of Operations Research	X				X
Zhuang et al. (2011b)	Proc. of 2011 NSF Engineering Research and Innovation Conference			X	X	
	Totals	18	7	14	12	10

time or resources to share information [9]. Because reliable information is so valuable, there exist strategic advantages to those who control its flow and incentives for agencies to compete for exposure to information flow [10]. Information is also a critical element in cooperative efforts. One potentially useful modeling framework is built on the notion of network centrality, where an agency's centrality score quantifies how integral an agency is to information flow. Scores are calculated using a network model; nodes represent agencies and edges between pairs of nodes are weighted to represent the amount of information flowing between them. Network centrality has been used to model inter-agency communication during the responses to the 2000 Mozambique floods [65] and to the September 11th, 2001, terrorist attacks [66]. The former paper finds a positive association between agency centrality scores and beneficiaries reached, which is attributed to the level of information access. Future research could quantify the strategic advantage of information access, benefits and costs of sharing information among agencies, and mechanisms to allocate benefits and costs.

Future research could advance the community's understanding of desirable and undesirable effects of media exposure. Is there empirical data to suggest that relief operations have been negatively affected in the past? If so, are there mechanisms that eliminate detrimental competition while conserving the benefits of media exposure? Are there policies that may ensure equitable access for beneficiaries in the presence of the media? How is the notion of media exposure changing with the rapidly increasing availability of smart phones and crowdsourcing of news?

While there is work concerning mechanisms for maximizing donations, there has been little research conducted on other ways that charities can obtain revenue. Some non-profits have begun auctioning goods and services. In fact, Bidding for Good ([www.biddingforgood.com](http://www.biddingforgood.com)) has raised over 160 million dollars for 6,200 non-profit organizations through online auctions. Similar websites include Charity Buzz ([www.charitybuzz.com](http://www.charitybuzz.com)) and Ready Set Auction ([www.readysetauction.com](http://www.readysetauction.com)). These sites provide powerful tools for NGOs to raise money with minimal upfront investment. However, there has been little analysis done to optimize

their use. How does altruism affect bidding? What type of auction structure serves the NGO best? What types of goods maximize the profit margin?

Considering the enormous rise in the number of non-profits, charities who want to survive must find a niche. Game theory offers tools to identify untapped markets in the presence of competition. Given an initial set of non-profits and their donors' behavior, how can a new organization find donors to build a cash flow? The Stackelberg model, a classic extensive game in which a new entrant to the market can observe a competitor before deciding upon his own strategy, may be modified to provide insight for this situation.

There exist numerous opportunities for research to guide cooperative relationships among NGOs, between NGOs and government or private entities, and within agencies. The literature points to the consequences of poor coordination, including duplicated work and under-served beneficiaries. While qualitative guidance is offered, for example, to encourage standardization and synergetic partnerships, quantitative models to inform and support cooperation are lacking. Future cooperative models may help NGOs find complementary partners, quantify the costs and benefits of a partnership, and determine a fair allocation of resources to optimize mutual goals. Balcik et al. [9] suggest the formation of supplier-buyer alliances to improve aid procurement through bulk-buying and shared shipping costs. Stewart et al. [67] suggest that non-profits partner with private businesses to improve a community's resiliency to disasters. Research efforts could also lead to approaches that combine facets of centralization in some areas and decentralization in others. Game theory offers a powerful framework for understanding and improving cooperation in the humanitarian context, where each link in a supply chain has a unique perspective and expertise.

Each humanitarian response occurs within a particular political context, meaning that the motivations and actions of political actors shape the response environment. This is true whether the entity in question is a host country government, foreign government, military authority, or militant group. When a government or military organization engages in relief operations, they bring a host of resources and skills. On the other hand, political realities

also mean that the safety of humanitarian personnel is a major concern in some regions. For instance, 90 aid workers were murdered in Afghanistan alone between 2003 and 2006 [56]. Games provide a tool to model ways that objectives and actions of political entities may impact humanitarian supply chain operations. Future research could lead to models that enable humanitarian logisticians to identify potential threats and vulnerabilities and develop strategies to increase supply chain security.

Much work remains in the creation of models that integrate decentralized beneficiaries' decisions. Future models may incorporate parameters besides distance and facility congestion, such as human behavior and social networks. For instance, more accurate demand estimates for public health emergencies may be generated via disease transmission models that use game theory to account for human decisions, such as that described in [68]. Furthermore, integrating beneficiary decision models with agency models in a comprehensive framework could significantly advance our understanding and management of humanitarian supply chain systems.

## 2.8 Relation to Thesis Objectives

Chapter 2 motivates the work presented in Chapters 3 and 4. A significant gap exists in the literature regarding the understanding of the role that decentralization plays in determining outcomes within humanitarian operations. It has been hypothesized that decentralized decision making may result in degraded supply chain efficiency and service to beneficiaries. However, there are very few contributions that attempt to quantify this degradation or suggest techniques for its mitigation. In the next chapter, the author focuses on decentralized systems of response agencies as they locate facilities to provide last-mile aid and medical treatment.

## Chapter 3

# Dynamic, Robust Location Models to Quantify the Impact of Decentralization on Service Accessibility

The author now consider humanitarian and public health operations in which service accessibility and equity can be negatively impacted when decisions about service location and capacity are made in a decentralized way. However, many humanitarian efforts lack a centralized authority who can coordinate the decisions across agencies. In this component of the thesis, the author introduces a framework for quantifying the impact of decentralization. A scenario-based robust optimization model is introduced that explicitly accounts for the uncertain, dynamic nature of humanitarian operations. The author demonstrates the approach using data from a large-scale public health response effort.

## 3.1 Introduction

Service accessibility is critically important to the effectiveness of many public health and humanitarian operations, and equitable access is often a goal in its own right. This research is motivated by response efforts to public health and humanitarian emergencies in which individuals choose a facility to visit for treatment or aid. When beneficiaries must travel to service sites, accessibility is directly impacted by the facilities' spatial distribution, their capacity, and the spatial distribution of demand. Thus, given anticipated demand for services and limited resources, facility location and capacity decisions are paramount to achieving access and equity.

Location decisions for public health and humanitarian response operations are often made under conditions that are dynamic, uncertain, and decentralized. Circumstances change rapidly, and accurate data about supply and demand are difficult to obtain. Furthermore, a lack of coordination among independent agencies regarding facility location decisions can lead to disparities in service accessibility across geographic space. Yet coordination between agencies is frequently limited due to time and resource constraints. In this decision making environment, multiple organizations act to deliver services, but the collective effort may be less efficient or equitable than what could be achieved with coordination.

This work makes two contributions. First, the author describes a centralized benchmark model that determines facility locations and capacities to optimize service accessibility and ensure equity. The scenario-based robust optimization model explicitly accounts for the uncertainty of operations, and it is embedded in a rolling horizon framework to capture the dynamics over time. Second, the method's usefulness is demonstrated in chapter 4 using data from an actual large-scale public health response, namely, the international effort to stem the cholera epidemic in Haiti. The author finds that the robust solution produced by the method provides improved treatment accessibility without requiring more resources.



## 3.2 Background

The contributions of this research are situated in the context of literature describing facility location models with one or more of the following components: measurements of access, efficient and equitable allocations, dynamic decision making, and parameter uncertainty. Facility location is a well-studied discipline with applications in supply chain management [69, 70, 71] and humanitarian response [72, 73, 74, 75, 76]. A comprehensive review of diverse objectives and applications for facility location problems can be found in [77].

Service accessibility is an important, multi-dimensional performance indicator in the public health sector. Potential access, or the opportunity to receive service, is distinguished from realized access, which measures whether or not an individual actually receives service [78]. Spatial accessibility measures the impact of geographic factors on access while aspatial access depends on characteristics including income, gender, and age [79, 80].

This research focuses on *potential spatial accessibility* to public health services and humanitarian aid. Measures of potential spatial accessibility in the literature include dimensions of proximity [70, 74], availability [81], or a combination [78, 82, 83, 84, 85]. Proximity refers to the cost of accessing a facility, which can be measured in terms of distance or transportation expense. Availability refers to the capacity for facilities to provide service. Availability has been measured by supply-to-demand ratios [82, 86], the time required to receive service [87, 88], or the congestion an individual experiences [89].

The optimization models presented in this research incorporate a measure of potential spatial accessibility based on the floating catchment area method. The method draws a circle around each population to identify service capacities within a reachable distance. Access is calculated based upon the supply and demand that lie within each circle. The floating catchment area method measures access as a function of both proximity and availability. Variations of the floating catchment area method have been applied with great success to measure accessibility of employment [90, 91], health care [82, 86, 92, 93, 94, 95, 96] and public transit services [97]. A significant benefit of this approach is that it does not

assign beneficiaries to facilities, nor does it simply assume they will visit the nearest one. Instead, the technique measures access to a region through a weighted capacity-to-demand ratio. The enhanced two-step floating catchment area method (E2SFCA) [82, 86] adds catchments around each facility to capture interaction from nearby facilities and includes a distance decay function to reflect beneficiaries’ decreasing ability to travel within catchments as distance increases.

In addition to the importance of accessibility, public health and humanitarian decision makers are often concerned with finding solutions that use resources efficiently. An efficient solution is one that accomplishes as much as possible with limited resources, often represented by an output-to-input ratio [84, 98, 99]. Measurements of efficiency include minimizing the average distance traveled per person, or maximizing the amount of aid that can be distributed per dollar spent. These measurements do not consider inconsistencies in service from one individual or region to another, but rather examine the performance cumulatively.

Equity refers to the absence of disparities in service between groups of people [100]. Equity is often a goal in its own right, especially in public health and humanitarian applications, even when it may conflict with efficiency. Equity is a social construct, the definition of which varies [81, 84, 85, 100, 101, 102] depending on the application and what is considered “fair” or “socially just”. Marsh and Schilling [103] summarize twenty different equity measurements. This research examines equity in terms of the variability of access across geographical regions, seeking solutions in which everyone can receive service.

In many public health and humanitarian settings, decisions are made in dynamic environments where information is subject to change. To integrate this reality, the model uses a rolling horizon to compute and periodically update decisions. The rolling horizon is a valuable modeling technique for dynamic systems that incorporate new information revealed over time [104, 105, 106]. For example, in the first period  $t_0$  of each planning horizon, the decision maker uses updated data to form a “plan”, which is a schedule for initializing,

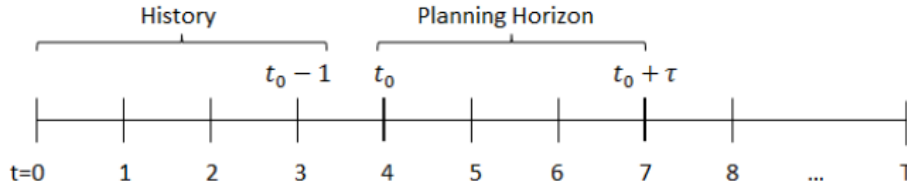

**Figure 3.1:** *A sample planning horizon.*

continuing, and terminating operations over the planning horizon. The planning horizon is defined as the set of time periods from  $t_0$  through  $t_0 + \tau$  for horizon length  $\tau$ . In the next period, the process is repeated so that a new plan is formed for each of  $T$  total periods. Figure 3.1 illustrates this concept.

Parameter uncertainty is common when locating facilities in both the commercial [107, 108] and humanitarian [76, 88, 109] sectors. The literature in this area can be categorized along three primary dimensions: the characterization of uncertainty, whether or not probability distributions are used, and whether the system is assumed to be static or dynamic. The uncertainty of a parameter may be represented by a set of scenarios [76, 110, 111] or may belong to a range of continuous values [69, 112, 113]. Stochastic models use probability distributions to describe the uncertain data [114, 115]. Models that do not make use of probability information are called robust and are implemented in cases where historical or forecasted data are unavailable. Robust models generate solutions intended to perform well upon any realization of the uncertainty [107]. Dynamic models allow for changes to uncertain parameters as new information is revealed over time, while static models do not [88, 112].

The majority of public health and humanitarian operations are carried out in highly decentralized environments. Coordination among agencies including government and non-governmental organizations (NGOs), private sector companies, and individuals may be limited due to urgency, damaged infrastructure, incompatible objectives, different languages, and varying units of measurement [9]. Duplication, inefficiency, and missed opportunities

can result in poorer outcomes than what could have been achieved with coordination and collaboration [1, 2].

The author addresses an important gap in the operations research literature with respect to public health and humanitarian operations. To fill the gap, this research introduces a framework to quantify the impact of decentralized facility location decisions on potential spatial accessibility and on equity. In doing so, the author explicitly addresses the need for robustness under uncertainty and dynamic decision capabilities.

### **3.3 Problem Specification and Methods**

In this section, the author describes the motivating context for this research and introduces a methodology that explicitly addresses the challenges of decentralization, uncertainty, and dynamism inherent in this context.

#### **3.3.1 Motivating Context**

This research is motivated by public health and humanitarian response efforts in which multiple organizations make decisions about where, when, and at what capacity to open service facilities. While each agency aims to have the greatest impact with its own resources, these decentralized decisions may cause geographic disparities in service accessibility. This in turn may negatively impact beneficiary outcomes.

The aim of this work is to quantify the impact of decentralization by constructing a centralized benchmark. The benchmark, a facility location model representing the decision making process of a hypothetical centralized planner, maximizes beneficiary access as measured with the E2SFCA method using scenario-based robust optimization.

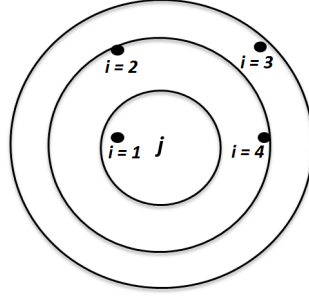

**Figure 3.2:** Three catchment zones capturing demand around facility  $j$ , where population location  $i = 1$  is in catchment zone 1,  $i = 2$  and  $i = 4$  are in catchment zone 2, and  $i = 3$  is in zone 3.

### 3.3.2 Access Metric

Consider a set of population locations  $N = \{1, 2, \dots, n\}$  indexed by  $i$ , where the demand of location  $i$  at time  $t$  is given by  $D_i^t$ . A set of facilities  $F^t$  is available to provide service during time period  $t$ . Facilities are denoted by  $j$  and distinguished by type, where the type  $K = \{1, 2, \dots, |K|\}$  determines the facility capacity.

Access for population  $i$  is measured using the E2SFCA method, which draws a catchment around each population and each facility. A catchment is the maximum distance an individual is able to travel to receive treatment and is divided into catchment zones  $z \in Z$ . If population  $i$  is within zone  $z$  of facility  $j$ , the binary parameter  $I_{izj}$  equals 1, otherwise it is 0. By symmetry, if population  $i$  is within zone  $z$  of facility  $j$ , then facility  $j$  is within zone  $z$  of population  $i$ . Figure 3.2 illustrates the concept of catchment zones for one facility, four population locations, and three catchment zones.

Uncertainty is represented by a set of scenarios. These scenarios represent the possible realizations of two uncertain parameters. The first is the capacity of a facility, which is given by  $C_{jks}^t$  for facility  $j$  of type  $k$  at time  $t$  under scenario  $s \in S$ . The second parameter is a beneficiary's ability to travel within the surrounding catchment. The parameter  $w_z^s$  is the ability-to-travel weight for catchment zone  $z$  in scenario  $s$ . In the public health and humanitarian sectors, facility capacities and beneficiaries' ability to travel are difficult to

predict, yet remain critical factors in determining the performance of a response. Therefore, it is important to seek robust solutions that perform well no matter what realization is observed.

The first step of the E2SFCA is to compute a weighted capacity-to-demand ratio for each facility  $j$ . This ratio includes the capacity parameter  $C_{jks}^t$  in the numerator while the denominator captures the demand within the catchment zones surrounding facility  $j$ , weighting each by  $w_z^s$  to represent beneficiaries that could feasibly travel to  $j$ . Mathematically, the capacity-to-demand ratio  $R_{jks}^t$  for facility  $j$  of type  $k$  at time  $t$  in scenario  $s$  is given by the following equation:

$$R_{jks}^t = \frac{C_{jks}^t}{\sum_{i \in N} \sum_{z \in Z} I_{izj} D_i^t w_z^s}.$$

In the second step of the E2SFCA, access for each population location  $i$  is calculated by summing the capacity-to-demand ratios of the facilities lying within the catchment zones surrounding  $i$ . If a facility  $j$  lies within catchment zone  $z$  of population  $i$ , its capacity-to-demand ratio is also weighted by  $w_z^s$ . Mathematically, the access of population  $i$  calculated during the planning horizon that begins in  $t_0$  for a period  $t \in \{t_0, t_0 + 1, \dots, t_0 + \tau\}$  under scenario  $s$  is

$$A_{is}^{t_0, t} = \sum_{j \in F^t} \sum_{k \in K} \sum_{z \in Z} R_{jks}^t I_{izj} w_z^s x_{jks}^t,$$

where  $x_{jks}^t$  is a decision variable that equals 1 if facility  $j$  is open as type  $k$  in period  $t$  in the centralized strategy for scenario  $s$ , 0 otherwise.

### 3.3.3 Model Formulation

The method consists of two sub-problems, called phases, that are solved repeatedly in a rolling horizon framework. In the first period  $t_0$  of a given planning horizon that includes periods  $t_0, \dots, t_0 + \tau$ , the phase 1 integer programming model generates a set of facility location decisions  $X_s^t$  for each scenario  $s \in S$  and time period  $t \in \{t_0, \dots, t_0 + \tau\}$ . Each scenario-optimized solution is an input to the phase 2 integer programming model that generates a robust set of facility location decisions  $X_{RO}^t$  for the same planning horizon. Based on the robust solution, the decisions for  $t_0$  are executed and those for each  $t$  in the periods  $t_0 + 1$  through  $t_0 + \tau$  are stored as plans for the future. The entire process is repeated in the next period, taking into account prior plans and new information that becomes available.

The objective in phase 1 focuses solely on efficiency, seeking solutions that ensure populations with the greatest need receive the greatest attention, while simultaneously avoiding the over-allocation of resources where they will go unused. The objective function in phase 1 accomplishes this by maximizing the cumulative demand-weighted access over the planning horizon. The cumulative demand-weighted access is calculated by the sum over populations of each population location's access score multiplied by its demand. In this way, access for a section with 100 units of demand is given 100 times more emphasis than a population location with one unit of demand.

Phase 2 computes the robust solution based upon an objective function that balances components of efficiency and equity. The first component minimizes the maximum regret  $\zeta^t$  in demand-weighted access over all scenarios. Maximum regret  $\zeta^t$  for time period  $t$  is measured as the largest cumulative difference in demand-weighted access between a solution in  $X_s^t$  and  $X_{RO}^t$  for all scenarios  $s \in S$ . To address equity, the second component of the robust objective function maximizes the number of populations that receive sufficient access in every scenario. Access is deemed sufficient if it is greater than or equal to a threshold  $\phi$ , which is a pre-determined capacity-to-demand ratio (weighted by the ability to travel) that

allows an average beneficiary to receive adequate service. The binary decision variable  $v_i^t$  equals 1 if population  $i$  has sufficient access in period  $t$  no matter what scenario is realized, 0 otherwise.

The centralized decision maker faces several restrictions, which are treated identically in phases one and two. First, the number of facilities opened of type  $k$  must be less than or equal to  $U_k^t$ , the number of facilities of type  $k$  that were available in the decentralized response at time  $t$ . Furthermore, the cumulative bed capacity of the facilities opened must be less than or equal to  $B^t$ , the total bed capacity available in period  $t$  of the decentralized response.

Upon receiving new information regarding candidate locations, capacity, and demand in each planning period  $t_0$ , the centralized decision maker may wish to modify the plan that was formed in  $t_0 - 1$ . However, the resources and communication required to execute a completely new plan are impractical. For this reason, the centralized benchmark limits the number of adjustments between plans from one period to the next by a percentage  $\delta$  of the number of facilities available.

Opening and closing facilities requires substantial effort. Therefore, a facility should only be opened if it can remain operational for a significant amount of time. The centralized benchmark addresses this consideration by setting a minimum facility life threshold  $m$ . If the decision is made to open a facility, it must remain open for at least  $m$  consecutive periods.

The parameters and decision variables used in the phase 1 and phase 2 models are summarized below.



## Parameters

$D_i^t$  = demand of population  $i$  in period  $t$

$C_{jks}^t$  = bed capacity of facility  $j$  if it is type  $k$  for period  $t$   
under scenario  $s$

$C_{jk}^t$  = bed capacity of facility  $j$  if it is type  $k$  in period  $t$  of decentralized response

$B^t$  = total bed capacity in period  $t$  of decentralized response

$R_{jks}^t$  = weighted bed capacity-to-demand ratio for facility  $j$  in period  $t$   
under scenario  $s$

$I_{izj}$  = 1 if facility  $j$  is within zone  $z$  of population  $i$ , 0 if not

$U_k^t$  = number of facilities of type  $k$  in decentralized response period  $t$

$M^t$  = total facilities in decentralized response in period  $t$ ,  $\sum_{k \in K} U_k^t$

$P_{js}^t$  = 1 if facility  $j$  is expected to be open in period  $t$  in last period's plan  
under scenario  $s$ , 0 if not

$P_{j,RO}^t$  = 1 if facility  $j$  is expected to be open in period  $t$  in last period's plan  
in the robust solution

$H_{jks}^t$  = 1 if facility  $j$  was open as type  $k$  in period  $t$  under scenario  $s$ , 0 if not

$H_{jk,RO}^t$  = 1 if facility  $j$  was open as type  $k$  in period  $t$  in the robust solution, 0 if not

$h_{jks}^t$  = 1 if facility  $j$  has been opened as type  $k$  before  $t$  under scenario  $s$ , 0 if not

$h_{jk,RO}^t$  = 1 if facility  $j$  has been opened as type  $k$  before  $t$  in the robust solution, 0 if not

$\gamma^t$  = phase 2 objective function weight on equity in period  $t$

$m$  = minimum allowable facility life (periods)

$\delta$  = plan flexibility percentage

$f_j^t = \max\{0, t - (\tau + t_0) + (m - 1)\}$ , relaxation for facilities to be open beyond  $\tau$

$t_0$  = current time period, start of planning horizon

$\phi$  = sufficient access threshold

$\tau$  = length of planning horizon

$T$  = last time period for facility decisions

## Decision Variables

$A_{is}^{t_0,t}$  = accessibility measure of population  $i$  at time  $t_0$  for period  $t$   
under scenario  $s$

$A_{is,RO}^t$  = accessibility measure in the robust solution of population  $i$  in period  $t$   
under scenario  $s$

$\zeta^t$  = maximum regret for period  $t$  in the robust solution

$v_i^t$  = 1 if population  $i$  has sufficient access over all scenarios in period  $t$   
in the robust solution, 0 if not

$x_{jks}^t$  = 1 if facility  $j$  is type  $k$  and is open in period  $t$  under scenario  $s$ , 0 if not

$x_{jk,RO}^t$  = 1 if facility  $j$  is open in period  $t$  in the robust solution, 0 if not

$y_{js}^{+t}$  = 1 if facility  $j$  is closed when planned to be open in period  $t$   
under scenario  $s$ , 0 if not

$y_{j,RO}^{+t}$  = 1 if facility  $j$  is closed when planned to be open in period  $t$   
in the robust solution, 0 if not

$y_{js}^{-t}$  = 1 if facility  $j$  is open when planned to be closed in period  $t$   
under scenario  $s$ , 0 if not

$y_{j,RO}^{-t}$  = 1 if facility  $j$  is open when planned to be closed in period  $t$   
in the robust solution, 0 if not

$z_{jks}^t$  = 1 if  $t$  is the period in which facility  $j$  was first opened as type  $k$   
under scenario  $s$ , 0 if not

$z_{jk,RO}^t$  = 1 if  $t$  is the period in which facility  $j$  was first opened as type  $k$   
in the robust solution, 0 if not

Phase 1

$$\text{Maximize } \sum_{t=t_0}^{t_0+\tau} \sum_{i \in N} D_i^t A_{is}^{t_0,t} \quad (3.1)$$

subject to

$$\sum_{k \in K} \sum_{j \in F^t} \sum_{z \in Z} R_{js}^t I_{izj} w_z^s x_{jks}^t = A_{is}^{t_0,t} \quad \forall i \in N, t \in \{t_0, \dots, t_0 + \tau\} \quad (3.2)$$

$$\sum_{j \in F^t} x_{jks}^t \leq U_k^t \quad \forall k \in K, t \in \{t_0, \dots, t_0 + \tau\} \quad (3.3)$$

$$\sum_{k \in K} \sum_{j \in F^t} C_{jks}^t x_{jks}^t \leq B^t \quad \forall t \in \{t_0, \dots, t_0 + \tau\} \quad (3.4)$$

$$\sum_{k \in K} x_{jks}^t \leq 1 \quad \forall j \in F^t, t \in \{t_0, \dots, t_0 + \tau\} \quad (3.5)$$

$$P_{js}^t - \sum_{k \in K} x_{jks}^t \leq y_{js}^{+t} \quad \forall j \in F^t, t \in \{t_0, \dots, t_0 + \tau\} \quad (3.6)$$

$$\sum_{k \in K} x_{jks}^t - P_{js}^t \leq y_{js}^{-t} \quad \forall j \in F^t, t \in \{t_0, \dots, t_0 + \tau\} \quad (3.7)$$

$$y_{js}^{+t} + y_{js}^{-t} \leq 1 \quad \forall j \in F^t, t \in \{t_0, \dots, t_0 + \tau\} \quad (3.8)$$

$$\sum_{j \in F^t} (y_{js}^{+t} + y_{js}^{-t}) \leq \delta M^t \quad \forall t \in \{t_0, \dots, t_0 + \tau\} \quad (3.9)$$

$$x_{jks}^t - x_{jks}^{t-1} \leq z_{jks}^t \quad \forall j \in F^t, k \in K, t \in \{t_0 + 1, \dots, t_0 + \tau\} \quad (3.10)$$

$$x_{jks}^{t_0} - H_{jks}^{t_0-1} \leq z_{jks}^{t_0} \quad \forall j \in F^{t_0}, k \in K \quad (3.11)$$

$$\sum_{t=t_0}^{t_0+\tau} z_{jks}^t + h_{jks}^{t_0} \leq 1 \quad \forall j \in F^t, k \in K \quad (3.12)$$

$$\sum_{l=0}^{t_0-1} H_{jks}^l + \sum_{t=t_0}^{t_0+\tau} (x_{jks}^t + z_{jks}^t f^t) \geq m \left( \sum_{t=t_0}^{t_0+\tau} z_{jks}^t + h_{jks}^{t_0} \right) \quad \forall j \in F^t, k \in K \quad (3.13)$$

$$x_{jks}^t, z_{jks}^t \in \{0, 1\} \quad \forall j \in F^t, k \in K, t \in \{t_0, \dots, t_0 + \tau\} \quad (3.14)$$

$$y_{js}^{+t}, y_{js}^{-t} \in \{0, 1\} \quad \forall j \in F^t, t \in \{t_0, \dots, t_0 + \tau\} \quad (3.15)$$

**Phase 2**

$$\text{Minimize } \sum_{t=t_0}^{t_0+\tau} \left( \zeta^t - \gamma^t \sum_{i \in N} v_i^t \right) \quad (3.16)$$

subject to

$$\sum_{k \in K} \sum_{j \in F^t} \sum_{z \in Z} R_{jks}^t I_{izj} w_z^s x_{jk,RO}^t = A_{is,RO}^t \quad \forall i \in N, s \in S, t \in \{t_0, \dots, t_0 + \tau\} \quad (3.17)$$

$$\sum_{i \in N} D_i^t (A_{is}^{t_0,t} - A_{is,RO}^t) \leq \zeta^t \quad \forall s \in S, t \in \{t_0, \dots, t_0 + \tau\} \quad (3.18)$$

$$\phi v_i^t \leq A_{is,RO}^t \quad \forall i \in N, s \in S, t \in \{t_0, \dots, t_0 + \tau\} \quad (3.19)$$

$$\sum_{j \in F^t} x_{jk,RO}^t \leq U_k^t \quad \forall k \in K, t \in \{t_0, \dots, t_0 + \tau\} \quad (3.20)$$

$$\sum_{k \in K} \sum_{j \in F^t} C_{jk}^t x_{jk,RO}^t \leq B^t \quad \forall t \in \{t_0, \dots, t_0 + \tau\} \quad (3.21)$$

$$\sum_{k \in K} x_{jk,RO}^t \leq 1 \quad \forall j \in F^t, t \in \{t_0, \dots, t_0 + \tau\} \quad (3.22)$$

$$P_{js}^t - \sum_{k \in K} x_{jk,RO}^t \leq y_{jp,RO}^{+t} \quad \forall j \in F^t, t \in \{t_0, \dots, t_0 + \tau\} \quad (3.23)$$

$$\sum_{k \in K} x_{jk,RO}^t - P_{j,RO}^t \leq y_{j,RO}^{-t} \quad \forall j \in F^t, t \in \{t_0, \dots, t_0 + \tau\} \quad (3.24)$$

$$y_{j,RO}^{+t} + y_{j,RO}^{-t} \leq 1 \quad \forall j \in F^t, t \in \{t_0, \dots, t_0 + \tau\} \quad (3.25)$$

$$\sum_{j \in F^t} (y_{j,RO}^{+t} + y_{j,RO}^{-t}) \leq \delta M^t \quad \forall t \in \{t_0, \dots, t_0 + \tau\} \quad (3.26)$$

$$x_{jk,RO}^t - x_{jk,RO}^{t-1} \leq z_{jk,RO}^t \quad \forall j \in F^t, k \in K, t \in \{t_0 + 1, \dots, t_0 + \tau\} \quad (3.27)$$

$$x_{jk,RO}^{t_0} - H_{jk,RO}^{t_0-1} \leq z_{jk,RO}^{t_0} \quad \forall j \in F^{t_0}, k \in K \quad (3.28)$$

$$\sum_{t=t_0}^{t_0+\tau} z_{jk,RO}^t + h_{jk,RO}^{t_0} \leq 1 \quad \forall j \in F^t, k \in K \quad (3.29)$$

$$\sum_{l=0}^{t_0-1} H_{jk,RO}^l + \sum_{t=t_0}^{t_0+\tau} (x_{jk,RO}^t + z_{jk,RO}^t f_j^t) \geq m \left( \sum_{t=t_0}^{t_0+\tau} z_{jk,RO}^t + h_{jk,RO}^t \right) \quad \forall j \in F^t, k \in K \quad (3.30)$$

$$x_{jk,RO}^t, z_{jk,RO}^t \in \{0, 1\} \quad \forall j \in F^t, k \in K, t \in \{t_0, \dots, t_0 + \tau\} \quad (3.31)$$

$$y_{j,RO}^{+t}, y_{j,RO}^{-t} \in \{0, 1\} \quad \forall j \in F^t, t \in \{t_0, \dots, t_0 + \tau\} \quad (3.32)$$

The objective function in phase 1 maximizes the cumulative demand-weighted access over the planning horizon. Constraint set (2) defines the projected access  $A_{i,s}^{t_0,t}$  of population  $i$  in scenario  $s$  in time period  $t_0$  for planning period  $t$ . For each facility type  $k$ , constraint set (3) prevents the total number of opened facilities from exceeding the number opened in a decentralized response. Constraint set (4) ensures that the total bed capacity of the centralized solution is no more than the bed capacity of the decentralized response. Constraint set (5) enforces the requirement that at most one type of facility may be open at a location in a given time period.

Constraint sets (6) through (9) relate the facility location decisions in the current planning horizon to the plans made in previous periods. Based on these relationships, constraint set (9) prevents decisions made in this period from deviating from prior plans by  $\delta$  percent of the total facilities available. Constraints (10) through (13) ensure that a facility of type  $k$  may only be opened once in each potential location and that if it is opened, it must remain opened for at least  $m$  consecutive periods. Upon implementation, constraint set (11) is only applied when the planning period  $t_0 > 1$  (once a plan has been established). Constraint sets (14) and (15) present the binary decision variables.

Each time the model generates a plan, the values of  $P_{js}^t$ ,  $H_{jks}^t$ , and  $h_{jks}^t$  are updated outside the model for all  $j \in F^t, k \in K, s \in S$  and  $t \in \{t_0, \dots, t_0 + \tau\}$ . The value  $f_j^t$  is also calculated outside the model and is used to satisfy constraint set (13) when a facility must stay open beyond the planning horizon to satisfy the constraint on  $m$  consecutive periods. (Please see the appendix for an example illustrating the use of this parameter.)

The objective function in phase 2 has two components. First, the objective function minimizes the maximum regret  $\zeta^t$  over all scenario realizations. Second, the objective function maximizes the number of regions who receive access that is greater than or equal to

a sufficiency threshold for every scenario. Constraint set (17) measures access  $A_{is,RO}^t$  for population  $i$  in the robust solution at time  $t$  under each scenario  $s$ . Maximum regret is defined in constraint set (18). For each scenario, the maximum regret is no less than the sum over population locations of the demand-weighted difference in access between the scenario-optimized solutions and the robust solution. Constraint set (19) allows the decision variable  $v_i^t$  to equal 1 only when sufficient access is given to population  $i$  at time  $t$  in the robust solution under every scenario. Constraint sets (20) and (21) ensure that the robust solution will not utilize more resources than were available in the decentralized response. Constraint set (22) limits a facility to one type. Constraint sets (23) through (30) govern the dynamic framework identically to constraints (6) through (13) in phase 1. The final two constraint sets establish the binary decision variables as they did in phase 1.

## 3.4 Computational Study

This section describes the results of a computational study using data from the response to a cholera outbreak in Haiti. Applying the methods presented in chapter 3.3, the author compares treatment accessibility in the actual decentralized response with a hypothetical, centrally-coordinated effort.

### 3.4.1 Context for Study

On January 12th, 2010, an earthquake rocked the small Caribbean country of Haiti. The earthquake is estimated to have caused 200,000 deaths and displaced 2.3 million people [116]. In the aftermath, cholera was introduced and, due to poor sanitation and damaged infrastructure, quickly spread throughout the country. Cholera is an intestinal infection caused by the bacterium, *Vibrio cholerae*. It can lead to diarrhea and vomiting to the point of extreme dehydration. Victims are treated with hydration salts or intravenous fluid replacement, but severe cases can cause death in just a few hours [117]. In response to the

outbreak, more than 110 NGOs opened hundreds of facilities to treat infected persons [118]. No single agency coordinated location decisions, leaving each organization responsible for positioning its own facilities.

The first cases of cholera were reported in October 2010 and by December, 3,990 people had perished. As of October 2013, there had been over 645,000 reported cases, causing more than 8,000 deaths [119]. The study focuses on the time frame between November 2010 and May 2011, during which 261,093 patients were treated in cholera treatment centers (CTCs) and smaller cholera treatment units (CTUs) [120]. A CTC contains between 30 and 500 beds and is staffed by trained physicians who are able to treat mild to severe cases. CTUs contain 20 to 30 beds operated by two or three nurses who are able to treat mild and moderate cases only [121]. In this study it is assumed that both types of facilities may operate 24 hours per day.

Haiti is divided into 570 geographically-defined sections, where a section is the fourth level of government following department, arrondissement, and commune. Demand estimates were obtained from the Ministry of Public Health and Population [122], the Haitian Institute of Statistics and Information [123], and the Centers for Disease Control and Prevention [120]. Data regarding facility locations and their capacities were obtained from the Pan American Health Organization (PAHO) [121]. Facility capacity is measured by the number of physical beds that can be simultaneously occupied at a given time.

During the response, resources were most abundant in the first two months, which enabled the largest number of facilities to be opened during this time. January brought a decline in resources that continued for the remainder of the study period. Figure 3.3 illustrates the number of CTCs and CTUs that were open in each month of the decentralized response. While the number of cholera cases actually decreased from November through January, it rose in February, peaked in March, and remained high in April. Figure 3.4 illustrates the number of patients seeking treatment and the total bed capacity that was available during each month.



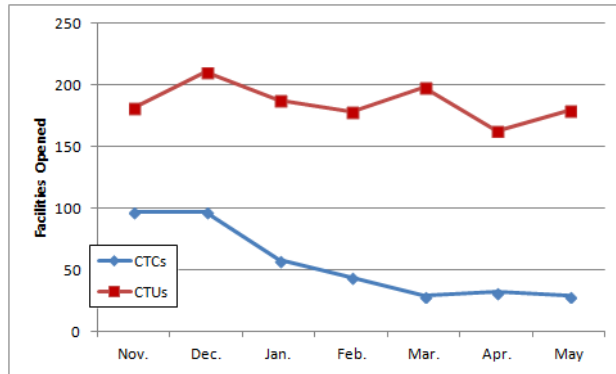

Figure 3.3: CTCs and CTUs available in decentralized response, Nov. 2010–May 2011.

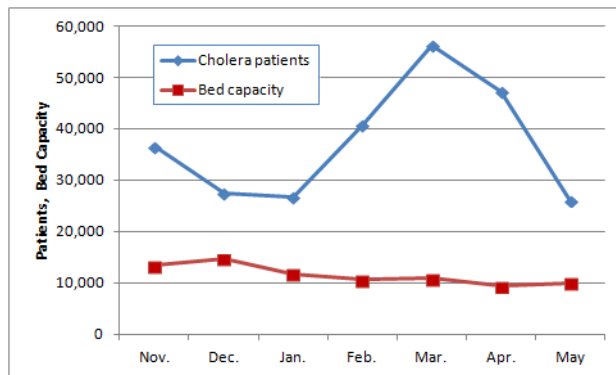

Figure 3.4: Total demand and bed capacity for each month, Nov. 2010–May 2011.

This study approximates the location of each population by the geographic centroid of its corresponding section, where boundaries are obtained from [121]. The distance between each population and each potential facility location is measured in kilometers (km). A 15km catchment around each population is divided into three concentric catchment zones with 5km, 10km, and 15km radii, respectively. A 15km catchment is chosen because cholera can be deadly if not treated within a few hours, and 5km is the average distance traveled in one hour of walking [121]. It is expected that the majority of beneficiaries will travel to facilities on foot because few people in Haiti own cars and the transportation infrastructure is weak [124].

Potential facility locations for the robust solution are created in two ways. First, the facilities that were opened during the actual decentralized response may be opened at their recorded locations. The second set of potential facility locations were created by constructing a 15km x 15km grid across Haiti where facilities may be opened at intersections of grid lines. Figure 3.5 plots each of these potential facilities. If a facility from the decentralized response is opened in the robust solution, its type and bed capacity are taken from the PAHO data. If the location belongs to the 15km grid, it can be either type and its bed capacity corresponds to the average bed capacity for the respective types, 80 beds for a CTC and 30 beds for a CTU. The grid creates an additional 126 locations, which corresponds to 252 potential facilities since each location may be opened as a CTC or CTU. In total, there are 700 potential facility locations that may be opened.

### 3.4.2 Study Design

The author first computes dynamic, robust facility locations in Haiti using base case parameter values. Scenarios for the study capture uncertainty in facility capacity and beneficiary ability to travel. The author compares efficiency, equity, and robustness measurements between the decentralized response and the robust solution. Finally, sensitivity analysis is conducted to understand how robust decision making responds to changes in the parame-

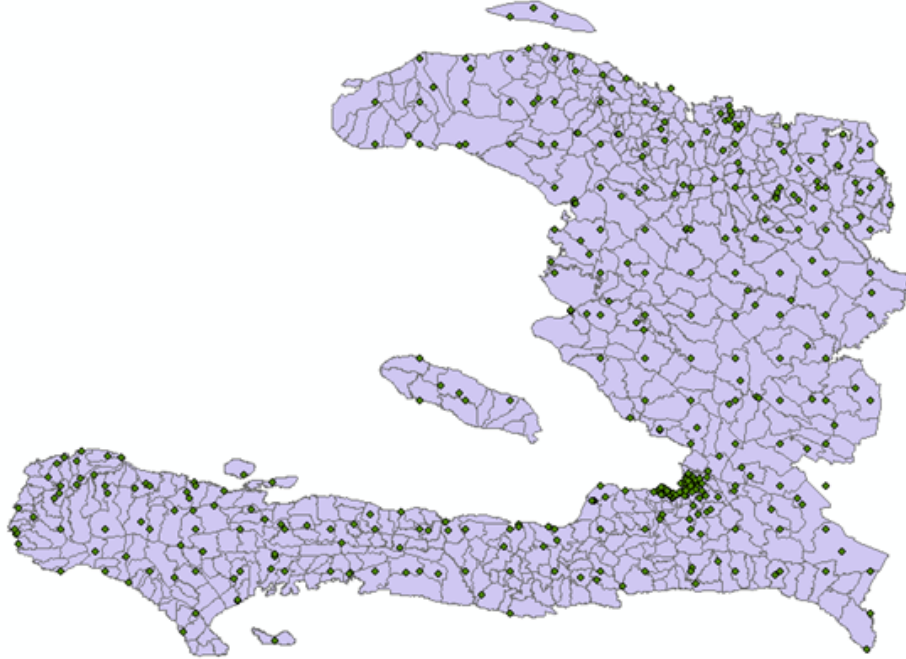

**Figure 3.5:** *Section boundaries and potential facility locations.*

ters that control plan flexibility, minimum facility life, and the emphasis placed on providing sufficient access to all sections.

The parameter values for the base case are as follows. The study uses a planning horizon length of  $\tau = 3$  to balance forward-looking strategy with over-reliance on less accurate long-term forecasts. To promote plan stability, a limit is placed on the number of changes between the previous period's plan and the current plan to at most 35 percent of the total facilities available (parameter  $\delta$ ). The minimum facility life,  $m$ , is three consecutive months. Lastly, the phase 2 objective function coefficient balances sufficient access with maximum regret through the parameter  $\gamma$ , which is set at 20. The access threshold,  $\phi$ , is 0.02. (See the appendix for an example that illustrates the meaning of this access value more concretely.)

The uncertainty set for the robust optimization is constructed using low, medium, and high levels for both capacity and ability to travel, resulting in a total of nine scenarios. Let  $\hat{C}_{jk}^t$  be the capacity that was reported in the decentralized response for facility  $j$  of type

$k$  at time  $t$ . For low-capacity scenarios,  $C_{jks}^t = \lfloor 0.7\hat{C}_{jk}^t \rfloor$ ; for medium-capacity scenarios,  $C_{jks}^t = \hat{C}_{jk}^t$ ; and for high-capacity scenarios,  $C_{jks}^t = \lfloor 1.3\hat{C}_{jk}^t \rfloor$ .

Ability-to-travel values correspond to the exponential decay function  $w_z^s = e^{\frac{-(z-1)}{\beta_s}}$  for catchment zone  $z \in Z$  similar to [96]. Low, medium, and high ability-to-travel realizations are generated using  $\beta_s$  values of 0.7, 1, and 1.4, respectively. The resulting ability-to-travel weights  $(w_1^s, w_2^s, w_3^s)$  for the three catchment zones are (1 0.239 0.057) for scenarios in which ability to travel is low, (1 0.368 0.135) when ability to travel is medium, and (1 0.489 0.239) when ability to travel is high. For the remainder of the chapter, the author refers to the scenario with low ability to travel and low facility capacities as the most unfavorable scenario realization.

Using these parameters, the methodology described in chapter 3.3 is implemented using ILOG OPL on a DELLXPS, running a 3.4 GHZ core i-7 processor with 8 GB of RAM. CPLEX reports ticks as a measure of computational effort that is more accurate than computation time. Optimizing all of the scenarios for the entire study period in phase 1 requires approximately 7,809 ticks (7 minutes) to complete. Generating the robust solutions for all time periods in phase 2 requires approximately 89,456.5 ticks (9 minutes, 30 seconds).

### 3.4.3 The Decentralized Response and the Robust Solution

This section presents efficiency, equity, and robustness results for the computational study. The decentralized response is defined as the set of facility locations and corresponding capacities that were available during the actual response in Haiti. The author refers to the solution generated using the methods described in chapter 3.3 as the robust solution.

#### 3.4.3.1 Location Decisions

Figures 3.6 and 3.7 display facility locations and access values for each month between November 2010 and May 2011. Dots denote open facility locations while shading corresponds to section-level access in the most unfavorable scenario realization, where darker shades

signify higher access. The left map is from the decentralized response while the middle displays the robust solution. The map on the right illustrates demand patterns where darker shades correspond to higher demand.

Facility location decisions between the robust solution and the decentralized response were very different. In total, 58 percent of the facilities opened in the robust solution come from the 15km x 15km grid. The most utilized type of facility is a CTU from the grid (45 percent) even though they comprise only 18 percent of the facilities available. CTCs from the grid represent 13 percent of the opened locations. The decentralized CTU locations are used for 34 percent of facility locations. Lastly, decentralized CTC locations represent only 7 percent of the opened locations.

Facilities in the decentralized response are most prevalent around densely populated areas but leave numerous rural areas under-served. Access in the decentralized response is greatest around Port-au-Prince, the capital and most populous city of Haiti. The robust solution also clusters facilities in densely populated areas. However, the robust solution emphasizes sufficient access to rural areas, spreading facilities across all sections. Aside from Port-au-Prince, the areas that receive the greatest access are in the north, especially in the beginning of the response.

One way to quantify differences between solutions is to count the number of deviations in facility location decisions. A deviation is counted if a facility that was open during time period  $t$  in one response is closed during  $t$  in the other. Conversely, a deviation is also counted if a facility that was closed during  $t$  in one response is open in the other. Figure 3.8 illustrates the number of deviations between the decentralized response and the robust solution as well as the number of facilities opened in each month of the robust solution. The number of deviations is highest in the beginning, reaching over 400 in December and decreasing later in the response. This pattern closely follows the number of facilities that were utilized in each month, which is intuitive as the number of deviations that may occur is directly tied to the number of facilities available.

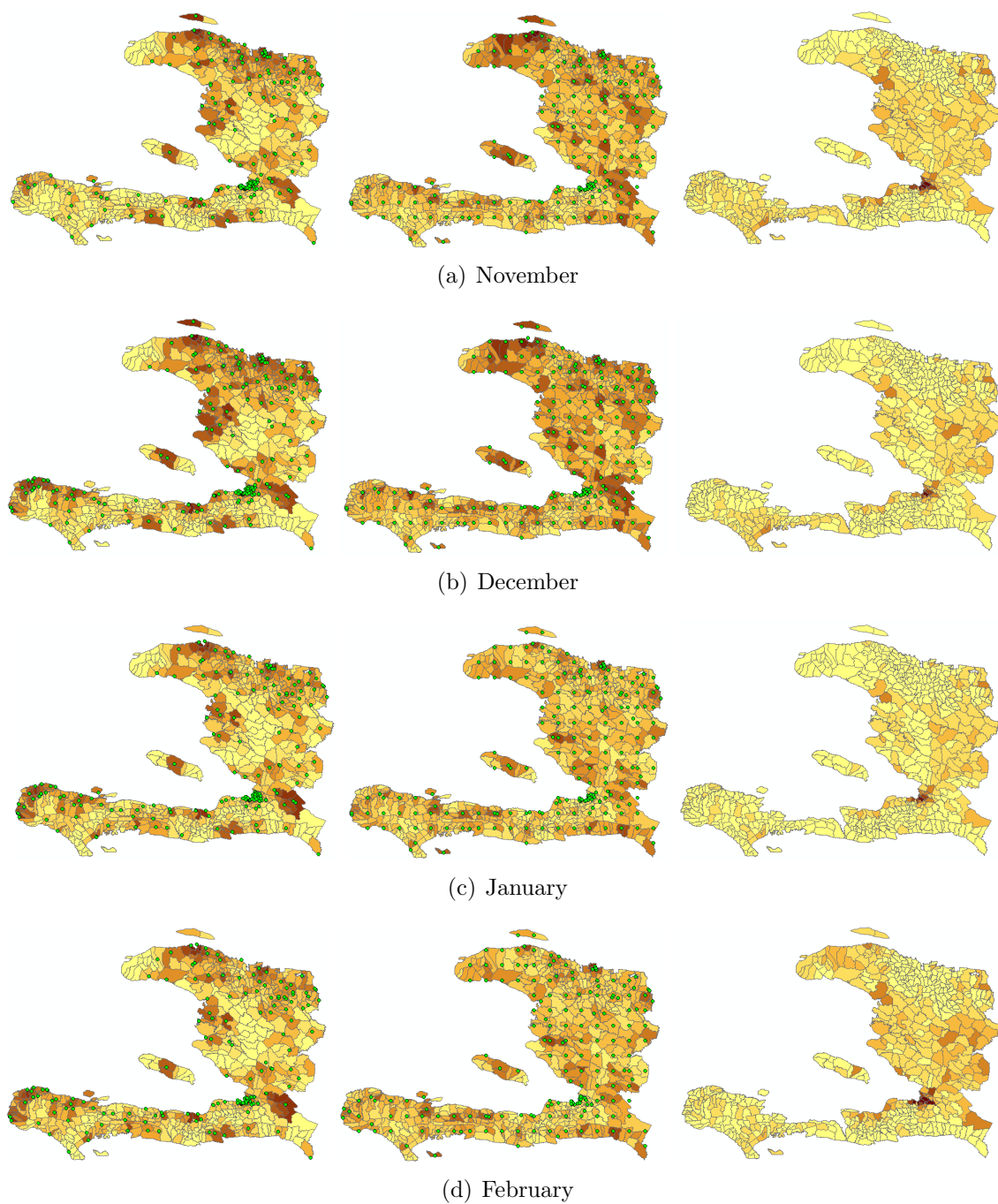

**Figure 3.6:** Maps displaying access in the decentralized response (left), access in the robust solution (center) and demand (right) for November through February; dots indicate open facilities. Access and demand legends are the same those shown in Figure 3.7.

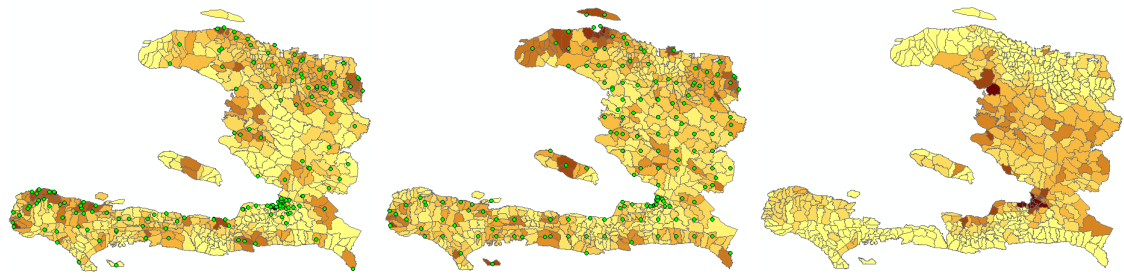

(a) March



(b) April



(c) May

Access: distance-weighted population-to-demand ratio

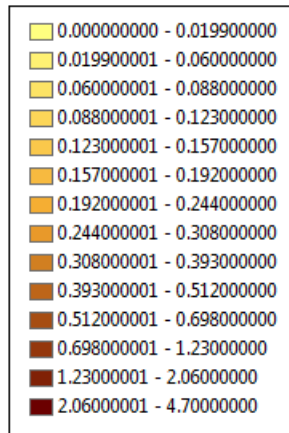

Demand: number of people

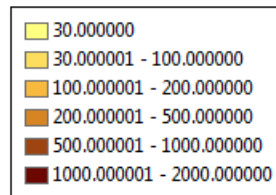

**Figure 3.7:** Maps displaying access in the decentralized response (left), access in the robust solution (center) and demand (right) for March through May; dots indicate open facilities.

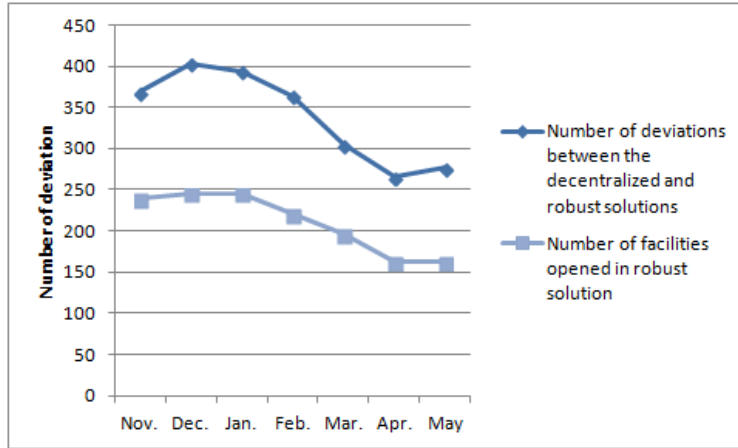

**Figure 3.8:** *Number of facility location deviations between the decentralized response and the robust solution by month, and total number of facilities opened in the robust solution.*

### 3.4.3.2 Average Access

The method produces an access score for each of the 570 sections in Haiti for every time period and scenario. Corresponding demand-weighted access is calculated by multiplying this score by the section’s demand. Aggregating these section-level measurements allows us to assess average access nationwide. Average access per section is calculated by summing the section-level demand-weighted access scores and dividing by the number of sections. In the decentralized response, average demand-weighted access is best between November and January in every scenario, reaching peak values in December. Access is lowest in April, which corresponds to the lowest number of available beds and the month with the second highest demand. Similar to the decentralized response, access in the robust solution is best from November through January in every scenario but decreases in the later months. In every scenario, the robust solution delivers higher demand-weighted access than the decentralized response in January through May. Interestingly, average demand-weighted access in the robust solution is actually worse than in the decentralized response in November and December. This results from the requirement that facilities remain open for at least three consecutive periods and the sudden capacity shortage in January. Thus, the decisions



made in November are constrained by the limited resources that are available in January.

To determine the robustness of the decentralized response and the computed solution, the author examines how average demand-weighted access varies from one scenario to another. As desired, the robust solution provides similar average demand-weighted access across ability-to-travel scenarios. This value changes between capacity scenarios proportionally to the change in capacity due to how access is calculated. Multiplying the capacity of a facility  $j$  by a constant causes a proportional increase in the value  $R_{jks}^t$ . Since access is the sum of capacity-to-demand ratios and the capacity of each facility is multiplied by the same constant, the access to each section is modified by the same scaling factor.

The percent improvement in access is calculated by dividing the difference in average demand-weighted access between the robust and decentralized solutions by the average demand-weighted access in the decentralized response. Using this metric, the robust solution outperforms the decentralized response from January through May in all scenarios. Figure 3.9 illustrates the percent improvement of the robust solution over the decentralized response in the most unfavorable scenario realization.

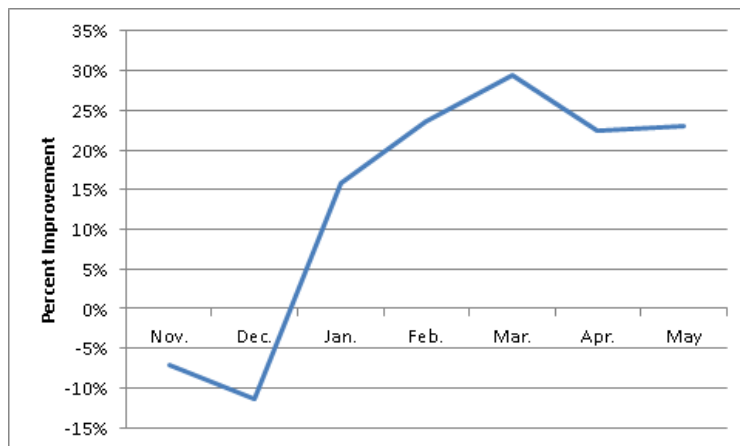

**Figure 3.9:** *Percent improvement in average demand-weighted access of the robust solution over the decentralized response in the most unfavorable scenario realization.*

The histogram in Figure 3.10 illustrates the distribution of average access over time for both the decentralized response and the robust solution in the most unfavorable scenario

realization. The X-axis label corresponds to the upper endpoint of access scores for each bin, and the height of the column corresponds to the number of sections with access scores in that bin. There are 64 sections whose average access in the decentralized response is insufficient, or less than 0.02; 17 of these receive no access at all. In both solutions, access for most sections lies between 0.1 and 0.3. However, access in the robust solution skews slightly farther to the right than in the decentralized response.

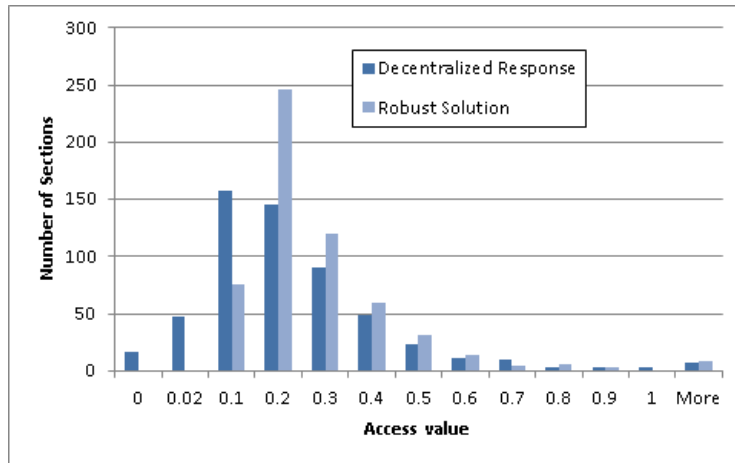

**Figure 3.10:** Histogram of access scores in the decentralized response and the robust solution in the most unfavorable scenario, where the x-axis label corresponds to the upper endpoint of access scores for each bin, and the height of the column corresponds to the number of sections with access scores in that bin.

### 3.4.3.3 Sufficient Access

Based on the preceding observations, the robust solution outperforms the decentralized response in terms of efficiency. Equity is also an important component of the robust methodology and is approached through the sufficiency requirement for every section. Sufficiency is highly influenced by both capacity and ability-to-travel scenarios in addition to monthly capacity and demand fluctuations. Decreasing ability to travel has the greatest impact in rural areas when optimizing demand-weighted access. It also affects equity in the low capacity scenario. This should be expected because if facilities have low capacities, people

may have to travel further to find a facility that is capable of providing service. The ability to travel has less of an impact in the middle and high capacity scenarios.

In the decentralized response, the number of sections with insufficient access varies significantly from month to month and across scenarios. Access sufficiency is best in December and January but worsens in March and April. Table 3.1 gives the number of sections with insufficient access in the decentralized response. No matter what scenario or month, there are always at least 37 sections with insufficient access. In March, under the most unfavorable scenario realization, there are 141 sections that receive insufficient access, comprising 24.7 percent of all sections. Several sections receive no access at all during certain periods in the decentralized response, at which time there were no proximal facilities. This means that an individual in one of these sections had to travel more than 15km for treatment, which may have been infeasible for many. Figure 3.11 displays sections who received insufficient access during some period in light shading and sections who received zero access at some point in dark shading. The sections that are not shaded received sufficient access in all periods.

**Table 3.1:** *Number of sections that received insufficient access in the decentralized response for each month under each scenario.*

Capacity		Low			Medium			High		
Ability to Travel		Low	Medium	High	Low	Medium	High	Low	Medium	High
Month	Nov.	92	69	53	72	51	50	65	50	46
	Dec.	76	49	44	54	42	40	49	38	37
	Jan.	78	57	46	65	46	43	54	43	42
	Feb.	88	67	61	70	58	51	65	51	48
	Mar.	141	121	107	121	102	89	107	89	82
	Apr.	128	110	95	113	92	81	99	81	76
	May	89	70	66	76	62	57	67	58	55

The robust solution provides sufficient access to many sections that did not receive it in the decentralized response and provides non-zero access to all sections in all scenarios. In the most unfavorable scenario realization, only one section receives insufficient access

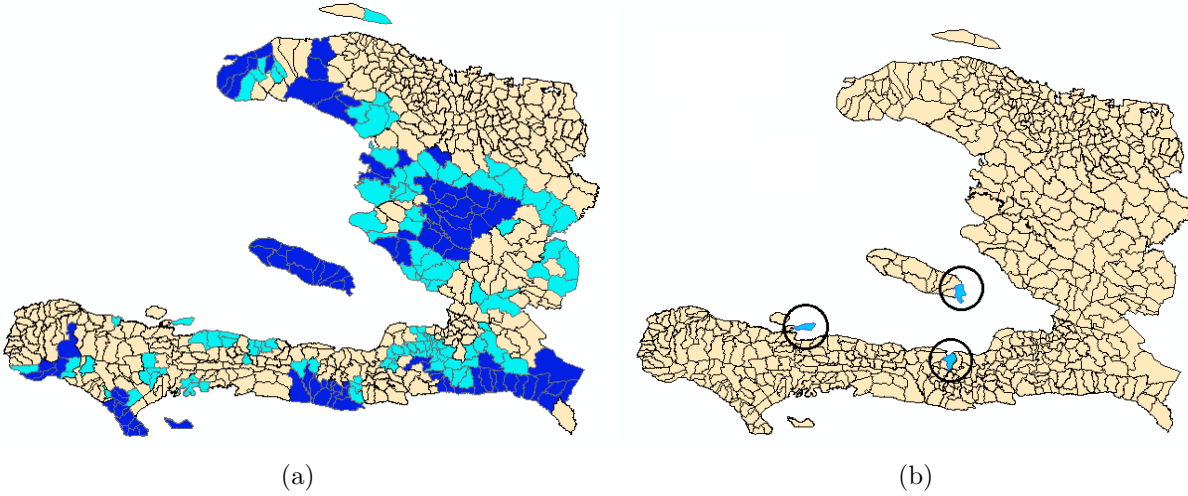

**Figure 3.11:** *Access sufficiency in the decentralized response (a) and robust solution (b); dark shading indicates sections with zero access and light shading those with insufficient access in at least one period of the most unfavorable scenario realization. The three sections that received insufficient access at some point in the robust solution are circled.*

in February, three in March, and two in April. The same section receives insufficient access from February through April when capacity and ability-to-travel values are low and in March when capacity is medium but ability to travel is low. In fact, it is impossible to provide sufficient access to that section in the most unfavorable scenario. In all scenarios, the number of sections who experience insufficient access reaches a maximum in March. In the decentralized response, the number of sections with insufficient access is 141 in the most unfavorable scenario realization. Under the same conditions, only three sections receive insufficient access in the robust solution. The dramatic decrease is due to the equity component of the objective function in phase 2, which provides access to sections with lower demand. This is one of the most significant findings of this study as it demonstrates that sufficient access was attainable for almost everyone if facilities had been located differently. Figure 3.11 plots the three sections that receive insufficient access at some point in the robust solution.

In summary, there are significant differences between the performance of the decentral-

ized response and the robust solution. The robust solution assigns more facilities to rural areas and responds to shifts in demand. Even in the most unfavorable scenario realization of the robust solution, 99.5 percent of Haiti’s 570 sections receive sufficient access throughout the entire response. When compared with 75.3 percent in the decentralized response, the results highlight significant opportunity.

### 3.4.4 Sensitivity Analysis

The robust model explicitly accounts for uncertainty in capacity and ability to travel, but it is useful to understand the sensitivity of the results to other parameter values. Here a sensitivity analysis is presented regarding the parameters that control plan flexibility, minimum facility life, and the emphasis placed on sufficiency, observing changes in facility location decisions and performance indicators. Table 3.2 illustrates parameter values that are tested.

**Table 3.2:** *Parameter values for the base case and sensitivity analysis.*

Parameter	Base case	Sensitivity analysis
$\delta$ , plan flexibility	0.35	0.25, 0.45
$m$ , minimum facility life	3	1, 2, 4
$\gamma$ , emphasis placed on equity	20	0, 50

#### 3.4.4.1 Plan Flexibility

The model restricts a plan to be modified by no more than a percentage  $\delta$  of the total facilities available in period  $t$ . The base case of this study assumes  $\delta = 0.35$ . The author now compares the base case with solutions obtained with  $\delta = 0.25$  and  $\delta = 0.45$  to explore the importance of plan flexibility. Figure 3.12 plots the number of facility location deviations in comparison to the base case over time. The number of deviations is small in the first three months of the response but increases sharply in February and remains high for the

rest of the response. It appears that the months in which the most plan modifications were desirable occur toward the end of the response when demand was high and resources were constrained.

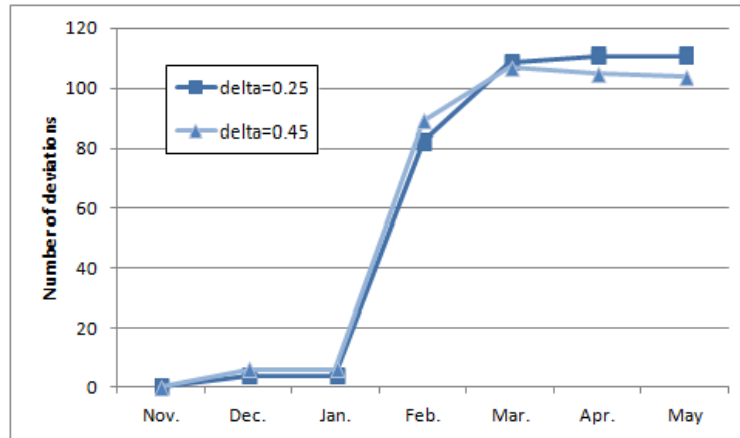
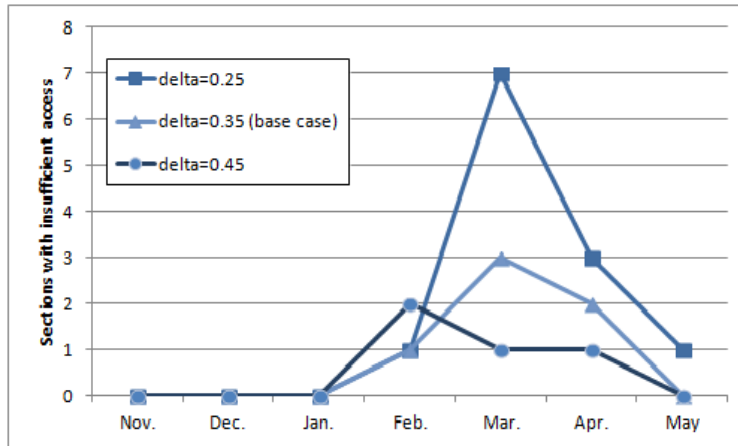

**Figure 3.12:** Facility location deviations from the base case ( $\delta = 0.35$ ) for experimental values of plan flexibility.

Plan flexibility does not impact average demand-weighted access in this study. Each experimental value of  $\delta$  resulted in similar average demand-weighted access across scenarios for each time period. Plan flexibility does influence equity of access, however. As would be expected, equitable access is most difficult to achieve in months with high demand and low resources, such as March. It makes sense, then, to see a spike in the number of sections with insufficient access in March. Figure 3.13 illustrates the gradual improvement in access sufficiency as plan flexibility increases.

#### 3.4.4.2 Minimum Facility Life

The minimum facility life,  $m$ , is the smallest number of consecutive time periods that an operational facility must remain open in the robust solution. In the base case, if a facility is opened, it must remain open for three consecutive months. Experimenting with robust solutions generated with  $m$  values of 1, 2, and 4 yielded significant results.



**Figure 3.13:** *The number of sections with insufficient access for experimental values of plan flexibility.*

Figure 3.14 illustrates that deviations in facility location decisions made in the base case are substantial and remain fairly consistent throughout the response when  $m$  is 1 or 2. When  $m$  is 4, however, the robust solution is initially very similarly to the base case, but the number of deviation increases sharply in February and remains high through May. Altering values of  $m$  significantly impacts facility location decisions, because the constraints that control minimum facility life are highly interactive with those that govern the number of open facilities.

The impact of facility life on demand-weighted access is summarized in Figure 3.15. In general, low values of  $m$  correspond to high average demand-weighted access scores. When  $m = 1$ , facilities may be located and relocated with great precision as demand shifts geographically. When  $m$  is 1 or 2, the robust solution gives greater demand-weighted access than the decentralized solution in every month and in every scenario. All of the experimental values provide better demand-weighted access in January through May. When  $m = 4$ , a substantial degradation in performance is observed in months with low resources as the robust solution barely outperforms the decentralized response. At the same time, the robust solutions with  $m = 1$  and  $m = 2$  result in over 25 percent greater average demand-weighted access than the decentralized response.

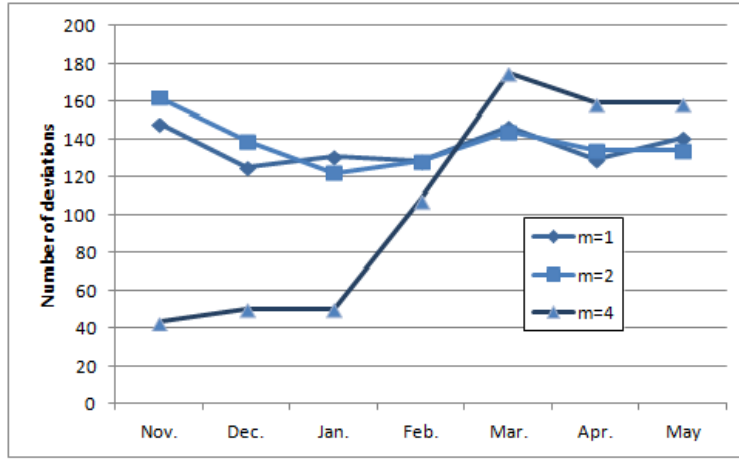

**Figure 3.14:** Facility location deviations from the base case ( $m = 3$ ) for experimental values of minimum facility life.

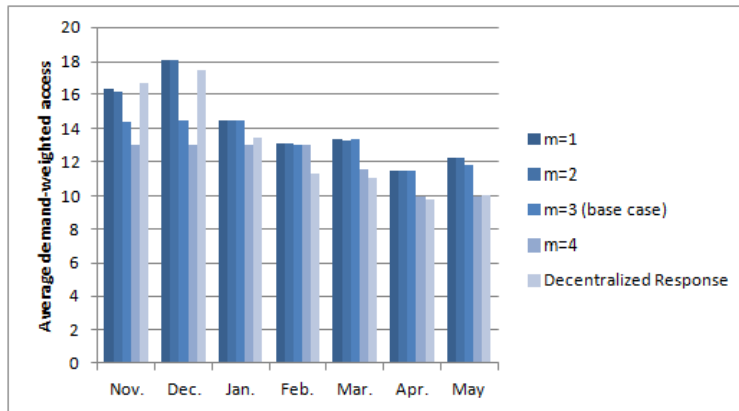

**Figure 3.15:** Average demand-weighted access for experimental values of minimum facility life over time.

Minimum facility life also influences equity, but on a much smaller scale. Since the base case only provided insufficient access to three sections in the most unfavorable scenario realization, the relative impact of changes in  $m$  is very small. In all cases, March remains the month in which the most sections receive insufficient access. When  $m$  is 1 or 2, only one section is ever in this category. As Figure 3.16 illustrates, when  $m = 4$  at most six sections ever receive insufficient access in the most unfavorable scenario realization of the robust solution. When compared with 141 sections that received insufficient access under



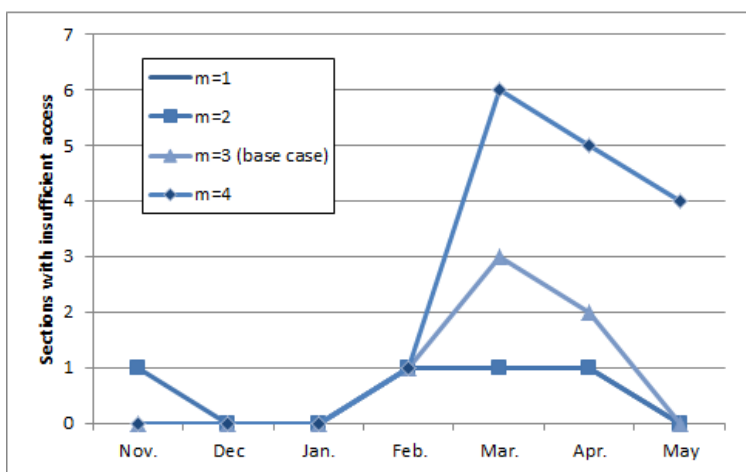

**Figure 3.16:** *The number of sections with insufficient access for experimental values of minimum facility life.*

the same conditions in the decentralized response, the difference is staggering.

### 3.4.4.3 Emphasis on Equity

The author finds that the value of  $\gamma$ , which controls the emphasis placed on sufficiency in the phase 2 objective function, impacts location decisions and equity but has little effect on average demand-weighted access. The base case results ( $\gamma = 20$ ) are compared with those obtained when  $\gamma = 0$  and  $\gamma = 50$ , respectively. The former does not consider sufficiency at all, while the latter places significantly more importance on this attribute.

Facility location decisions deviate from those in the base case for both  $\gamma = 0$  and  $\gamma = 50$ , as illustrated in Figure 3.17, especially in the last four months of the study period. The differences are most pronounced for  $\gamma = 0$ , indicating that when no emphasis is placed on sufficiency, facility location decisions are very distinct in months with limited resources.

Changing the value of  $\gamma$  has very little impact on average demand-weighted access. For instance, in the base case when  $\gamma = 20$ , the average-demand weighted access is 11.44 in April. This value improves to 11.46 when  $\gamma = 0$  but decreases to 11.34 when  $\gamma = 50$ .

However, a far greater impact is observed in access equity. When no emphasis is placed

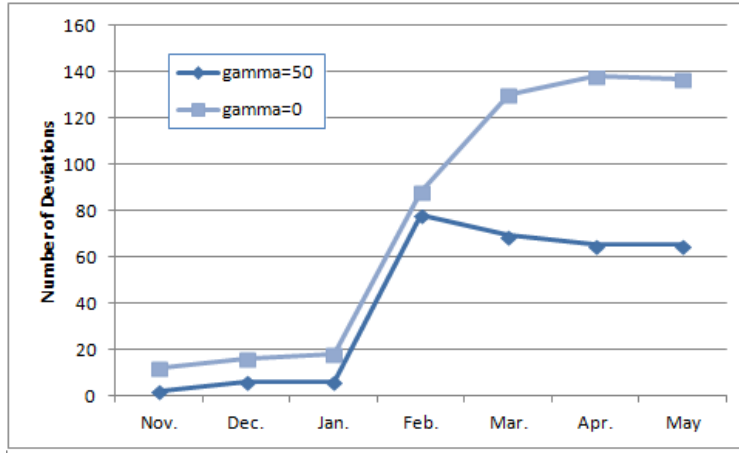

**Figure 3.17:** Facility location deviations from the base case ( $\gamma = 20$ ) for experimental values of equity emphasis.

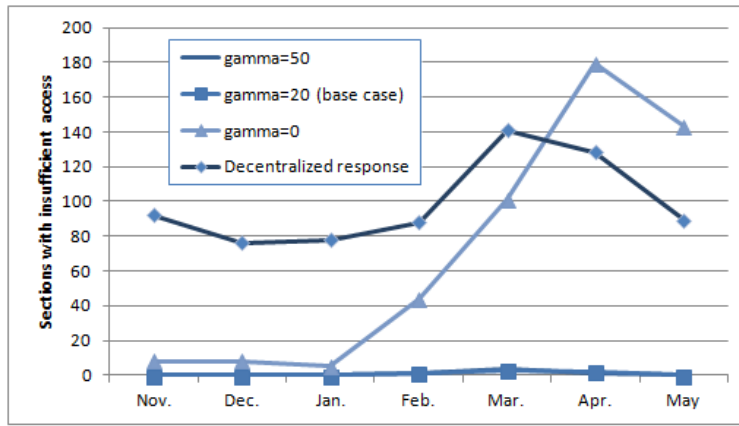

**Figure 3.18:** The number of sections with insufficient access for experimental values of equity emphasis. The values for  $\gamma = 20$  (base case) and  $\gamma = 50$  are identical, overlapping in the graph.

on sufficiency, the robust solution results in a greater number of sections with insufficient access than the decentralized response in April and May. Otherwise, robust solutions for all  $\gamma$  values outperform the decentralized response in equity for every month. Figure 3.18 illustrates the number of sections with insufficient access in the most unfavorable scenario realization for each tested value of  $\gamma$ . The author concludes that emphasis on equity is necessary if individuals in rural areas are to receive reasonable access to treatment.

### 3.4.5 Discussion of Results

This computational study leads to several interesting findings. First and foremost, the robust solution provides better demand-weighted access while simultaneously providing more sections with sufficient access than the decentralized response. The decentralized response focused primarily on densely populated areas, leaving some rural areas under-served. The robust solution takes advantage of grid locations to provide adequate service to rural areas while maintaining clusters of facilities where demand is high.

The ability to travel does not affect average demand-weighted access for the data set and parameter values that were used. However, increases in demand-weighted access are proportional to increases in capacity. Both uncertain parameters affect equity as the number of sections that receive sufficient access varies significantly across scenarios.

Through sensitivity analysis, it is observed that plan flexibility does not impact demand-weighted access. However, as a disease spreads, deviations from previous plans will be required to provide adequate access to everyone.

Changing the minimum facility life has a great impact on demand-weighted access. The base case provides worse demand-weighted access than the decentralized response in November and December. Yet when  $m$  is 1 or 2, the robust solution outperforms the decentralized response in every month and in every scenario by taking full advantage of resources available in the early months of the response.

Finally, this study illustrates that an emphasis on equity is vital if people in rural areas are to be given sufficient access. When the centralized benchmark did not consider equity, the resulting solution gave sufficient access to fewer sections than the decentralized response. Thus, optimizing only metrics of efficiency such as demand-weighted access are inadequate, and may result in inequities in potential spatial accessibility across regions.

## 3.5 Conclusion and Future Research

The author presents a methodology to quantify the impact of decentralization and improve accessibility in the public health and humanitarian sectors. This approach provides advances over existing models by explicitly incorporating the inherent uncertainty and dynamism that are prevalent in this sector. It produces solutions that are robust and that ensure equitable access under a range of potential scenario realizations. The method also facilitates a comparison between a hypothetical strategy of complete inter-agency coordination and an actual decentralized response. Such evidence can strengthen the case for coordination and highlight the need for resources to facilitate coordinated decision making, given the additional effort and cost that are required. It may be necessary to provide incentives such as public recognition to agencies that agree to locate their facilities in areas that otherwise may be ignored.

The results of the computational study using data from the Haiti cholera response clearly identify potential for improvement through more coordinated facility location decisions. The decentralized response in Haiti provided much-needed care for cholera patients. However, this analysis suggests that several sections in Haiti experienced limited access to treatment resources, which may have led to poorer outcomes. The robust solution outperformed the decentralized response in both efficiency and equity, while using the same resources.

This research provides a foundation for future research, both in terms of the modeling and in terms of addressing barriers to practical implementation. Exploring alternative objective functions or introducing additional scenarios in the robust optimization could provide additional insights into the tradeoffs inherent between efficiency and equity. Research is also needed to explore the types of coordination mechanisms or decision support tools that would make it possible to achieve coordination in practice.

## 3.6 Connection to the Thesis

This chapter presents models that enable the quantification of performance degradation attributed to decentralization. When the models are applied to an actual response, a substantial gap is observed between the service provided in reality and that which might have been provided through coordinative efforts. The author turns to systems of beneficiaries in Chapter 4 and applies game theory to predict behavior, prove bounds on the cost of outcomes, and present mechanisms that encourage individuals to act in a centrally optimal manner.

# Chapter 4

## Equilibria, Performance Bounds, and Coordination Mechanisms in Decentralized Systems of Beneficiaries

Now that the impact of decentralization has been analyzed for systems of response agencies, the author turns to systems of beneficiaries seeking treatment.

### 4.1 Introduction

Beneficiaries often make independent decisions about where to receive service, which ultimately determine the spatial distribution of demand. As there often does not exist a central authority empowered to direct beneficiaries to facilities, the decentralization of beneficiaries can lead to poor outcomes. Centralized models that do not consider decisions made at the individual level cannot foresee this inefficiency. This research models beneficiary decisions using a congestion game that incorporates realistic individual preferences through novel player utility functions.

The author focuses on two factors that are important to the decision making process:

the distance that must be traveled and the congestion experienced at a facility. The analysis is framed within a congestion game, which consists of a set of players and a set of facilities. Each player simultaneously chooses a facility to optimize the utility he receives from his choice, where utility is a function of distance to the facility and congestion, or the total number of players that choose that facility.

Two types of player utility functions are described in this thesis. Both include distance, congestion, and a multiplier applied to congestion to model the relative importance of the two components. This multiplier is called a congestion weight. In the first type of utility function, the congestion weight is a player and facility-specific constant, allowing each player to emphasize congestion differently at each facility. In a public health context, beneficiaries may prefer service at one facility over another due to familiarity with an area, perceived quality, or a preferred service provider. For the second type of utility function, the congestion weight is a player-specific constant. This utility function applies individual feelings about congestion identically to all facilities. This type of utility function is appropriate if service is perceived to be the same at every facility.

Integral to the analysis of congestion games is the concept of Nash equilibrium [16]. A Nash equilibrium (NE) is an outcome of a game in which no player can improve his payoff by unilaterally altering his choice of strategy. In other words, no player would deviate from his decision upon observing the other players' choices. As equilibria represent the outcomes of self-interested decisions, they most closely reflect what will be observed in reality. Thus, the ability to identify equilibria in advance may be extremely valuable to demand forecasts and resource allocation.

It is important to understand the impact that individual preferences have on the performance of decentralized systems. To address this, the author proves bounds on the cost of outcomes in terms of the least and most costly equilibrium solutions from a global perspective. It is shown that individual preferences may result in extremely costly outcomes. Thus, the author introduces coordination mechanisms that modify player utility functions

to drive self-interested decisions toward what is best for the system as a whole. Mathematically, this is accomplished by identifying the appropriate congestion weights that make a centralized optimum also an equilibrium. In practice, if agencies can alter beneficiaries' utility functions through incentives such transportation assistance, or by sharing information concerning congestion via posted signs or updates on social media, they may not only forecast the spatial distribution of demand, but also shape it toward what will optimize system performance.

In chapter 4.2, a review of literature on congestion games is presented and an important gap is identified. The classes of congestion games utilized in this work are defined mathematically in chapter 4.3. In chapter 4.4, the author focuses on the congestion game where each player weighs congestion independently for each facility. Additional results are presented in chapter 4.5 for the special case in which each player applies a player-specific congestion weight to all facilities identically. In chapter 4.6, an optimization model is introduced to identify coordination mechanisms in practice. The value of the model is demonstrated through a computational study using data obtained from a recent cholera epidemic. Finally, a discussion of the implications of results is presented in chapter 4.7 along with conclusions.

## 4.2 Background

This research begins by examining the literature concerning congestion game models. Contributions focus primarily on the existence of and complexity of computing Nash equilibrium solutions, comparing the quality of an equilibrium to a centralized optimum, and methods for closing the gap between decentralized and centralized behavior. This research makes theoretical contributions on all three fronts with specific application to humanitarian operations.

A congestion game consists of a set of players and a set of resources (facilities). Each player chooses facilities to minimize his utility function, where the utility derived is non-



decreasing in the total number of players that choose a certain facility.

Classes of congestion games differ from one another on many dimensions. In general congestion games, players may utilize multiple facilities [125, 126, 127], but singleton congestion games require that a player chooses exactly one facility [128]. There also exists a distinction between weighted and unweighted congestion games. In weighted congestion games, each player may introduce a different workload to the system [129, 130]. In unweighted congestion games, each player simply has a workload equal to one unit. Some congestion games are splittable, meaning that a player may divide his workload among different facilities continuously [131]. In the unsplittable case, the workload must all be assigned to the same facility.

Atomic games model situations where the decision of each player has a non-negligible impact on the overall performance of a system, where in non-atomic games, the effect of a player's strategy is negligible, and only the cumulative effect of players' decisions has a measurable impact on a system [132]. A congestion game may also be classified as either symmetric or asymmetric. In a symmetric game, all players have the same set of strategies from which to choose [133]. If the strategies available to each player may differ [134], the game is said to be asymmetric.

Congestion games are also classified according to the form of players' utility functions. Some games incorporate a common, or facility-specific, utility that is applied identically to every player who chooses a certain facility [133]. For games with player-specific utilities, the utility derived from the selection of a certain facility is independent for each player and facility combination [135].

In this work, the author analyzes two classes of unweighted, singleton, atomic congestion games with player-specific utility functions. In the first, each player may place a different weight on congestion at each facility. To differentiate the two, the author denotes the utility functions in the first case as player-facility-specific. In the second game, each player weighs congestion independently from one another but applies the weight identically to

every facility.

The complexity of computing NE for congestion games has received much attention from the research community. A useful technique involves an exact potential function. A function is an exact potential function if, given two solutions that differ only in the action of a single player, the change in the function is equal to the change in that player's utility. Exact potential functions are important because a local minimum of a potential function corresponds to an equilibrium [133]. The existence of a potential function also indicates that a game possesses the finite improvement property (FIP) [136], which implies that given any solution, any sequence of player moves in which the moving player's utility improves leads to an equilibrium in a finite number of steps [1, 137].

Milchtaich shows that an equilibrium solution can be computed in polynomial time when player-specific utility functions are monotonic in congestion [135], a class that does not admit an exact potential function in general. Both classes of congestion games presented in this work are monotonic in congestion and therefore, computing an equilibrium can be done in polynomial time. However, an alternative proof for one class is presented in chapter 4.5.

The price of stability (PS) and price of anarchy (PA) are measures of a decentralized system with respect to that same system under centralized control [138]. The PS is the ratio of the centralized objective function value of the least costly equilibrium to the centralized objective function value of the centralized optimum. It is a measure of the best possible outcome in a decentralized setting. Conversely, the PA is the ratio of the centralized objective function value of the most costly equilibrium to the centralized objective function value of a centralized optimum, measuring the cost of the worst possible outcome. If these measures for a certain instance are large, it means that self-interested decisions may result in poor system performance.

Coordination mechanisms refer to methods for improving equilibrium solutions [139]. Through the application of a coordination mechanism, individuals choose a strategy that aligns with what is best for the overall system. Applying the concept of coordination

mechanisms to congestion games, contributions to the literature identify modifications to players' utility functions so that an individual is incentivized to make the same decision that a centralized planner would make for him [1]. For the game considered in this research, such mechanisms seek to alter the weight a player places on congestion.

The results relevant to this work are illustrated in Figure 4.1. There are three classes of utility functions in the literature, which the author denotes as A, B, and C. Class A is the most specific utility function, Class B is more general, and Class C is the most general. Figure 4.1 displays results with each type of utility function and categorizes games as weighted or unweighted, and general or singleton.

Class A is a common cost function where all players weigh congestion at a certain facility identically but that the weight may be different for each facility [134, 140]. For the weighted, general form, a NE always exists with two players if utility functions are monotonic [140]. For three or more players, a NE always exists if utility functions are either affine, or exponential [140]. Unweighted congestion games always possess the FIP and computing an equilibrium is *PLS*-complete [134], signifying that all other *PLS*-complete problems can be reduced from it. A problem is in *PLS* (polynomial-time local search) if the following can be done in polynomial time: an initial solution can be generated, its objective value can be determined, it can be verified whether the solution is a local optimum, and if not, a neighbor with a better objective value can be identified [141]. A neighbor is defined as a closely related instance, often differing in the strategy of a single player. The price of anarchy when utility functions are of class A is at most 2.5 [142], even when the game is asymmetric [130].

Class B is a more general form of Class A, adding a player-facility-specific constant to the common cost function. In Class A, this constant is set to zero. In symmetric, unweighted congestion games with utility functions of Class C, computing an equilibrium for can be done in polynomial time [1, 143], but for the asymmetric case it is *PLS*-complete [143, 127, 134] in general. However, for certain structures in this class, computing an equilibrium solution can be done in polynomial time [1].

Bounds on the price of anarchy for games with utility functions of Class B are demonstrated in terms of the greatest and least congestion weights [1]. It is also shown that the price of stability for this game is no worse than when a player does not weigh congestion at all [1]. Lastly, the problem of finding congestion weights that make the centralized optimum also an equilibrium is framed as an optimization model [1].

Class C is the most general utility structure, replacing the common cost function in Class B with a player-facility-specific cost function and possibly adding a player-facility-specific constant. This utility function allows that each player to weigh congestion differently at each facility. Utility functions of Class C reflect the idea that an individual may apply personal preferences for one facility over another. Research has been conducted for this class when utility functions are monotonic in congestion [135], or specifically a multiple of congestion [131]. The weighted, general form does not possess the FIP [131] except in the singleton case [135], and when there are only two facilities [137]. The unweighted form possesses the FIP when utility functions are multiples of congestion [131]. For congestion games where players' utilities may be arbitrary values, it is *NP*-complete to determine whether a game possesses a NE [125], signifying that there does not exist a polynomial time algorithm to compute an equilibrium unless  $P = NP$ . Finally, Ackerman [125] constructs a polynomial-time algorithm to compute an equilibrium solution for matroid games.

There exists a major gap in knowledge regarding performance bounds and coordination mechanisms when utility functions are of Class C as can be observed in the corresponding sections of Figure 4.1. In this work, the author introduces two classes of unweighted, singleton congestion games that apply utility functions of class C, making several contributions. First, new bounds on the prices of anarchy and stability are demonstrated for both classes of games. Next, the author investigates coordination mechanisms, characterizing instances for which there exist congestion weights that, when applied, encourage centrally optimal behavior. The author also verifies a previous result by presenting an alternate proof on the complexity of finding an equilibrium solution. Finally, the author constructs and implements

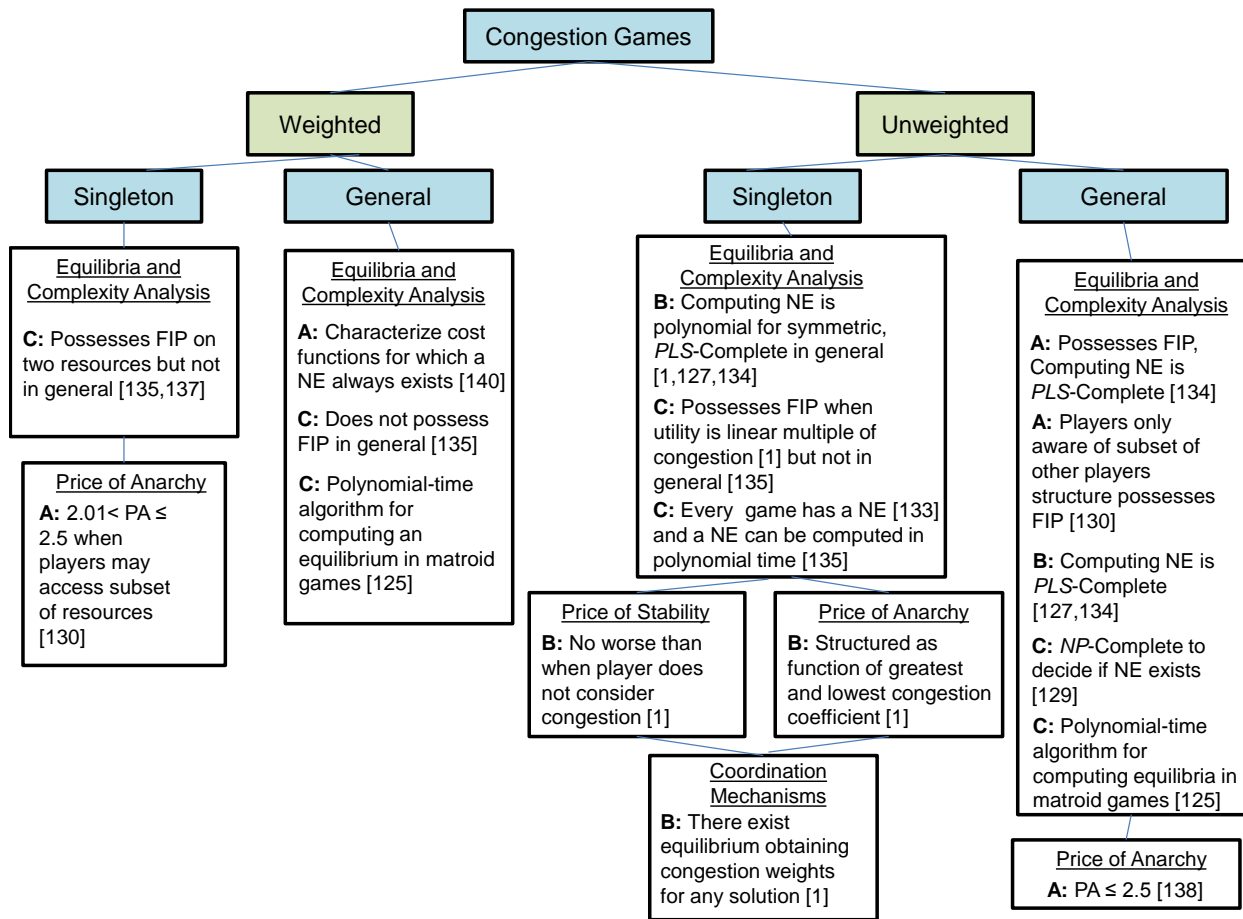

Figure 4.1: Categorization of results concerning congestion games.

an optimization model that computes congestion weights that make a central optimum also an equilibrium at minimal cost.

### 4.3 Model and Definitions

The author models beneficiaries' facility choices as a symmetric network congestion game with unweighted, unsplittable flow. Players' utilities are linear functions of the distance to a facility and the number of other players at the facility. The relative importance of these two components is represented by a multiplier applied to the congestion term of the utility function. In the general case, this weight may depend on both the player and the facility, giving rise to what is called the Player-Facility-Specific Congestion Weights Problem (PFSCWP). The author also considers the special case in which the weight depends only on the player, the Player-Specific Congestion Weights Problem (PSCWP).

Formally, the PFSCWP is defined on a directed graph  $G = (N \cup F \cup t, A)$ .  $N = \{1, 2, \dots, n\}$  is a set of players,  $F = \{1, 2, \dots, m\}$  is a set of facilities, and  $t$  is a dummy sink node. There exists an arc between each player  $i$  and each facility  $j$  with a cost equal to the distance  $d_{ij}$ . There also exists an arc between each facility  $j$  and the sink node with a cost equal to the number of players who choose facility  $j$ , denoted  $x_j$ .

The action of each player  $i$  is represented as a path from his node to the sink node  $t$ , passing through a facility node  $j$ , illustrated in Figure 4.2(a). Each player receives utility from his choice of path in terms of the costs on the arcs of his chosen path. Because each player may weigh congestion independently for each facility, a congestion weight  $\alpha_{ij}$  is defined for each player  $i$  and facility  $j$  combination. Thus, the utility of player  $i$  at chosen facility  $j$  is calculated by  $u_{ij}(x_j) = \alpha_{ij}x_j + d_{ij}$ . The PSCWP is a special case of the PFSCWP where  $\alpha_i$  replaces  $\alpha_{ij}$  for all facilities  $j$ .

A solution  $X$  consists of each player choosing exactly one facility. For some results, a solution  $X$  is denoted by  $X = (j_1, j_2, \dots, j_n)$ , where  $j_i$  is the facility chosen by player  $i$ .

A solution is a Nash equilibrium if no player is able to decrease his utility by choosing a different facility upon observing the selections of the other players. This is represented using a set of inequalities for each player.

**Definition 1** *Let  $j$  be the facility at which player  $i$  is served in solution  $X$  in an instance of the PFSCWP. The equilibrium condition for player  $i$  is  $\alpha_{ij}x_j + d_{ij} \leq \alpha_{ik}(x_k + 1) + d_{ik}$ , for all  $k \neq j \in F$ .*

A NE solution is one in which the equilibrium condition holds for all players. It is important to note that Nash equilibrium solutions do not necessarily imply optimal payoffs for any player. Instead, they represent the outcome of decisions made in a player's self-interest and the assumption that other players will do likewise.

Outcomes of decentralized decisions are contrasted with a centralized planner who assigns players to facilities to minimize cumulative congestion experienced and distance traveled in the entire system. The centralized planner's problem is illustrated in Figure 4.2(b). The only difference between the centralized and individuals problems is the cost on the sink arcs. The centralized planner's problem is defined mathematically by the following optimization model.

$$\text{Minimize } Z(X) = \sum_{j=1}^m \left( \sum_{i=1}^n x_{ij} \right)^2 + \sum_{i=1}^n d_{ij}x_{ij}$$

subject to

$$\sum_{j=1}^m x_{ij} = 1 \quad \forall i \in N$$

$$x_{ij} \in \{0, 1\} \quad \forall i \in N, j \in F$$

The decision variable  $x_{ij}$  equals one if player  $i$  is assigned to facility  $j$ . The first term in  $Z(X)$  is squared to represent the fact that each player experiences the congestion put upon

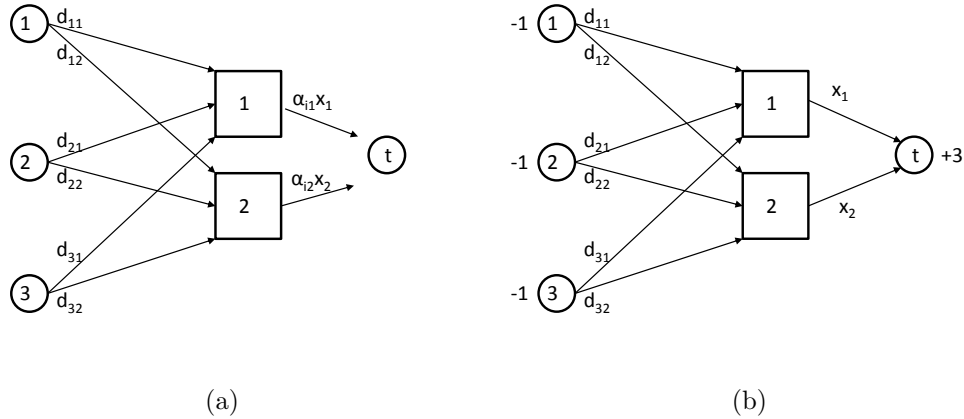

**Figure 4.2:** *The Player-Facility-Specific Congestion Weights Problem (a) and the centralized planner's problem (b).*

him by the other players at his facility. The only set of constraints ensures that each player is assigned to exactly one facility. The centralized planner's problem is a convex cost flow problem and can be solved in polynomial time.

## 4.4 Analysis of the PFSCWP

In many applications, an individual may place a different emphasis on congestion at different facilities. This utility function is appropriate when an individual may prefer service from a particular provider or in a certain area. In these cases, while the distance remains unaffected, the relative importance of distance and congestion may depend on the chosen facility. The author now analyzes the PFSCWP in which the utility of a player  $i$  at chosen facility  $j$  is given by  $u_{ij}(x_j) = \alpha_{ij}x_j + d_{ij}$ , where  $\alpha_{ij}$  is the congestion weight for player  $i$  at facility  $j$ . In this section, the author proves bounds on the prices of anarchy and stability and shows that there exist congestion weights that make any solution an equilibrium, including the centralized optimum.



### 4.4.1 Bounds on Performance

In this section, the author introduces bounds on the price anarchy and the price of stability for the PFSCWP with varying restrictions on input parameters. It is shown that individual preferences can result in very poor outcomes from a centralized perspective. The author also demonstrates that the most costly solution from the centralized planner's perspective can also be a Nash equilibrium. These findings are summarized in Table 4.1.

#### 4.4.1.1 Bounds on Price of Anarchy

The author now focuses on the cost of the most expensive equilibrium, deriving bounds when  $\alpha_{ij} \geq 0$ , when  $\alpha_{ij} \geq 1$ , and when  $d_{ij} = 0$  for all  $i \in N$  and  $j \in F$ .

In the following theorem, the author shows that when  $\alpha_{ij} \geq 0$  for all  $i \in N$ , the price of anarchy is a function of the largest and smallest congestion weights. The proof follows the technique of [1] and is a foundation for other results in this section.

**Theorem 1** *When  $\alpha_{ij} \geq 0$  and  $d_{ij} \geq 0$  for all  $i \in N$  and  $j \in F$ , the price of anarchy for the PFSCWP satisfies  $\alpha_{max} - n\alpha_{min} + n \leq PA$ , where  $\alpha_{min}$  and  $\alpha_{max}$  are the least and greatest congestion weights over the set of players and facilities.*

*Proof.* Consider an instance  $G$  of the PFSCWP with  $n$  players and  $n + 1$  facilities. Let  $d_{ij} = 0$  for all  $i \in N$  and  $j \in \{1, 2, \dots, n\}$ ; let  $d_{i,n+1} = \alpha_{max} - n\alpha_{min}$  for all  $i \in N$ . Let  $\alpha_{ij} = \alpha_{max}$  for all  $i \in N$  and  $j \in \{1, 2, \dots, n\}$ ; let  $\alpha_{i,n+1} = \alpha_{min}$  for all  $i \in N$ .

The most costly solution is the one in which all players are assigned to facility  $n + 1$ , obtaining a total cost equal to  $n^2 + n(\alpha_{max} - n\alpha_{min})$ . The utility of each player in this solution is  $n\alpha_{min} + \alpha_{max} - n\alpha_{min} = \alpha_{max}$ . This is an equilibrium because if a player switches to another facility, his utility will remain  $\alpha_{max}$ .

A centralized optimum assigns exactly one player to each of facilities  $j \in \{1, 2, \dots, n\}$ , obtaining a total cost equal to  $n$ . The price of anarchy for this instance is equal to  $\left(n^2 + n(\alpha_{max} - n\alpha_{min})\right)/n = \alpha_{max} - n\alpha_{min} + n$ . Therefore, the price of anarchy for the class of

**Table 4.1:** Performance bounds for the PFSCWP.

Criteria	PA Lower Bound	PA Upper Bound
$\alpha_{ij} \geq 0, d_{ij} \geq 0$ $n$ players, $n + 1$ facilities	$\alpha_{max} - n\alpha_{min} + n$ (Theorem 1)	
$\alpha_{ij} \geq 0, d_{ij} \geq 0$ $n$ players, $m$ facilities	$m + 1 - \left(2(m - 1)/n\right)$ when $d_{max} \geq 2\left(\frac{n}{m-1} - 1\right)$ (Theorem 2)	
$\alpha_{ij} \geq 0, d_{ij} = 0$ $n$ players, $m$ facilities	$\Omega(m)$ (Theorem 3)	$O(m)$ (Theorem 3)
$\alpha_{ij} > 0, d_{ij} \geq 0$ $n$ players, $m$ facilities	$\lfloor \frac{\alpha_{max}}{\alpha_{min}} \rfloor$ (Corollary 1)	$\frac{2.5(\alpha_{max}+1)^2}{\alpha_{min}}$ (Corollary 3)
$\alpha_{ij} \geq 1, d_{ij} \geq 0$ $n$ players, $m$ facilities	$\alpha_{max} + 1$ (Corollary 4)	$2.5\alpha_{max}$ (Corollary 4)
$\alpha_{ij} \geq 1, d_{ij} \geq 0$ $n$ players, $n + 1$ facilities	$\Omega(n + C)$ (Theorem 4)	$O(n + C)$ (Theorem 4)

games where  $\alpha_{ij} \geq 0$  for all  $i \in N$  is at least as much.  $\square$

Theorem 1 demonstrates that if one player places a large weight on a congestion while another player places a small weight, then the system outcome may be very costly. In practice, the system cost of an equilibrium may be lessened if beneficiaries place similar weights on congestion.

**Corollary 1** *When  $\alpha_{ij} > 0$  and  $d_{ij} \geq 0$  for all  $i \in N$  and  $j \in F$ , the price of anarchy for the PFSCWP satisfies  $\lfloor \alpha_{max}/\alpha_{min} \rfloor \leq PA$ , where  $\alpha_{min}$  and  $\alpha_{max}$  are the least and greatest congestion weights over the set of players, respectively.*

*Proof.* Consider an instance  $G$  of the PFSCWP with  $n = \lfloor \alpha_{max}/\alpha_{min} \rfloor$  players on the same network defined in Theorem 1. The price of anarchy for the instance is  $n + \alpha_{max} - n\alpha_{min}$ . The component  $\alpha_{max} - n\alpha_{min} = \alpha_{max} - \lfloor \alpha_{max}/\alpha_{min} \rfloor \alpha_{min} \geq 0$ . Therefore,  $PA \geq n = \lfloor \alpha_{max}/\alpha_{min} \rfloor$ .  $\square$

Applying a proof technique similar to that in Theorem 1, a lower bound is identified for instances with  $n$  players and  $m$  facilities.

**Theorem 2** *When  $\alpha_{ij} \geq 0$  and  $d_{ij} \geq 0$  for all  $i \in N$  and  $j \in F$ , the price of anarchy for the PFSCWP satisfies  $m + 1 - \left(2(m-1)/n\right) \leq PA$ .*

*Proof.* Consider an instance  $G$  of the PFSCWP with  $n$  players  $i \in \{1, 2, \dots, n\}$  and  $m$  facilities  $j \in \{1, 2, \dots, m\}$ . Let  $d_{ij} = 0$  for all  $i \in N$  and  $j \in \{1, 2, \dots, m-1\}$  and  $d_{im} = 2(n/(m-1) - 1)$  for all  $i \in N$ . Lastly, let  $\alpha_{ij} = 1$  for all  $i \in N$  and  $j \in \{1, \dots, m-1\}$  and  $\alpha_{im} = n + 2n/(m-1)$  for all  $i \in N$ .

The solution with the highest possible cost is an equilibrium, assigning all players to facility  $m$  and incurring a total cost equal to  $n^2 + \sum_{i \in N} d_{im}$ . The centralized optimum divides players evenly among facilities  $1, 2, \dots, m-1$ , incurring a total cost equal to  $(m-1) \left( n/(m-1) \right)^2 = n^2/(m-1)$ .

$$\begin{aligned} \text{Thus, } PA &= \frac{n^2 + \sum_{i \in N} d_{im}}{\frac{n^2}{m-1}} \\ &= \frac{n^2 + n \left( 2 \left( \frac{n}{m-1} - 1 \right) \right)}{\frac{n^2}{m-1}} \end{aligned}$$

After simplification, this leads to  $PA = m + 1 - \left( 2(m-1)/n \right)$ . Since an instance exists where  $m + 1 - \left( 2(m-1)/n \right) = PA$ , the price of anarchy for the entire class must be at least as much.  $\square$

This proof illustrates the relationship between the number of players and the number of facilities as it relates to the price of anarchy. In practice, if the number of beneficiaries is the same or greater than the number of facilities, equilibrium solutions may be extremely costly from a system view. However, the price of anarchy decreases with a decrease in beneficiaries.

The author now quantifies the price of anarchy for congestion games in which  $d_{ij} = 0$  for all players  $i$  and facilities  $j$ .

**Theorem 3** *When  $\alpha_{ij} \geq 0$  for all  $i \in N$  and  $d_{ij} = 0$  for all  $i \in N$  and  $j \in F$ , the price of anarchy for the PFSCWP with  $n$  players and  $m$  facilities is  $\theta(m)$ .*

*Proof.* The solution that achieves the greatest total cost for this class of games assigns all players to the same facility  $j$ , incurring a cost equal to  $n^2$ . The solution with the lowest possible cost for this class of games is obtained by evenly distributing players among the  $m$  facilities, incurring a total cost equal to  $m(n/m)^2 = n^2/m$ . The ratio of the most expensive and least expensive solutions is clearly an upper bound on the PA for this class of problems. Thus  $PA \leq n^2/(n^2/m) = m$ . Therefore,  $PA \in O(m)$ .

Consider an instance  $G$  of the PFSCWP with  $n$  players and  $m$  facilities where  $d_{ij} = 0$  for all  $i \in N$  and  $j \in F$ . Let  $\alpha_{ij} = 1$  for all  $i \in N$  and  $j \in \{1, \dots, m-1\}$  and  $\alpha_{im} = 1/n$  for all  $i \in N$ . In this instance, the solution that assigns all players to facility  $m$  is an

equilibrium, achieving the highest possible cost from a centralized perspective ( $n^2$ ). The central optimum distributes all players evenly among the  $m$  facilities achieving the lowest possible cost ( $n^2/m$ ). The price of anarchy for this instance is  $n^2/(n^2/m) = m$ . Since there exists an instance where the price of anarchy is  $m$ , this value provides a lower bound on the price of anarchy for this class of problems. Thus,  $PA \in \Omega(m)$ .

Combining the two results, the price of anarchy when  $d_{ij} = 0$  for all  $i \in N$  and  $j \in F$  is  $\theta(m)$ . □

If distance is not a factor in the decision making process for either the centralized planner or the beneficiaries, the price of anarchy increases with the number of facilities.

The author now demonstrates that when  $\alpha_{ij} \geq 1$  and  $d_{ij} \geq 0$  for all  $i \in N$  and  $j \in F$ , a similar technique may be applied so that the most expensive solution possible is an equilibrium and the least expensive solution possible is the centralized optimum.

**Theorem 4** *When  $\alpha_{ij} \geq 1$  and  $d_{ij} \geq 0$  for all  $i \in N$  and  $j \in F$ , the price of anarchy for the PFSCWP with  $n$  players and  $m$  facilities is  $\theta(n + C)$  for some constant  $C$ .*

*Proof.* The solution with the greatest possible total cost achieves maximal values in both the congestion and distance components of the centralized planner's objective function. The greatest possible value for the congestion component is  $n^2$  which occurs when all players are assigned to the same facility. The greatest possible value of the distance component is achieved when each player  $i$  is assigned to his furthest facility  $d_{i,max}$ . Thus, the greatest possible value of the centralized planner's objective function is  $n^2 + \sum_{i \in N} d_{i,max}$ .

The solution with the lowest possible total cost minimizes both components of the centralized planner's objective function. The smallest possible value in the congestion component is  $n$ , which is achieved when each player is assigned to his own facility. The smallest possible value in distance component is zero. Thus, the lowest possible value to the centralized planner's objective function is  $n$ .

The ratio of the most expensive and least expensive solutions is clearly an upper bound on

the PA for this class of problems. Thus,  $PA \leq (n^2 + \sum_{i \in N} d_{i,max})/n$ . Therefore,  $PA \in O(n+C)$  where  $C$  is the sum of the distances  $d_{i,max}$  divided by  $n$ .

Consider an instance  $G$  to the PFSCWP with  $n$  players denoted  $i_1, i_2, \dots, i_n$  and  $n+1$  facilities denoted  $j_1, j_2, \dots, j_{n+1}$  as illustrated in Figure 4.3. Let  $d_{i_k j_l} = 0$  for all  $i_k \in N$  and  $j_l \in \{j_1, j_2, \dots, j_n\}$ . Let  $d_{i_k, j_{n+1}} = d_{max} > 0$  for all  $i_k \in N$ . Let  $\alpha_{i_k j_l} = n + d_{max}$  for all  $i_k \in N, j_l \in \{j_1, j_2, \dots, j_n\}$  and  $\alpha_{i_k, j_{n+1}} = 1$  for all  $i_k \in N$ . The centralized planner assigns each player  $i_k$  to facility  $j_k$ , obtaining  $Z(X^*) = n$ .

The solution  $X$  with the highest system cost assigns every player to facility  $n+1$  and is an equilibrium. The utility of each player is  $n + d_{max}$ . If a player would choose another facility, his utility would remain  $n + d_{max}$ . The centralized objective value  $Z(X) = n^2 + n d_{max}$ . This is the greatest possible congestion cost, and because all players are assigned to the facility that is farthest away from them, the distance cost is also maximized. Therefore,  $X$  is the most costly solution and an equilibrium.

Since there exists an instance where the price of anarchy is  $(n^2 + n(d_{max}))/n = n + d_{max}$ , this value provides a lower bound for this class of games. Therefore, the price of anarchy  $\in \Omega(n + C)$ .

Combining the two components of this proof, the price of anarchy  $\in \theta(n + C)$ .  $\square$

Theorem 4 demonstrates that given certain congestion weights, players might prefer to travel the maximum distance and experience the maximum amount of congestion because they prefer one facility much more than the others. This proof once again underscores the importance of coordination mechanisms to help players make better decisions from a system perspective.

Theorems 1 through 4 present performance bounds on classes of the PFSCWP when  $\alpha_{ij} \geq 0$ ,  $\alpha_{ij} > 0$ ,  $\alpha_{ij} \geq 1$  and  $d_{ij} = 0$  for all  $i \in N$  and  $j \in F$ . The author shows that bounds on the price of anarchy can be presented in terms of players' congestion weights or the numbers of players and facilities. In general, the price of anarchy grows with the range between the least and greatest congestion weights, and also with the numbers of players and

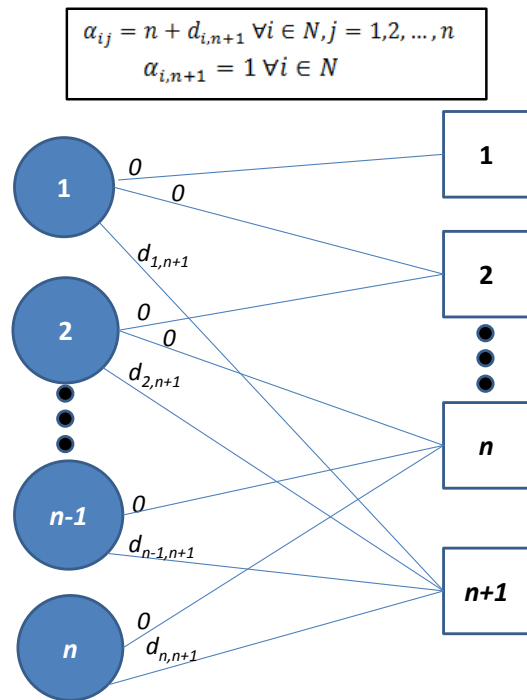

**Figure 4.3:** *Illustration of the network constructed in Theorem 4.*

facilities. Theorem 3 is special case of Theorem 2, demonstrating the additional complexity that arises when  $d_{ij} > 0$ .

#### 4.4.1.2 Bounds on Price of Stability

Having seen that the worst equilibrium can be costly, it is also important to quantify the performance of the best equilibrium for this class of games. The author now demonstrates that in the PFSCWP, the price of stability may be arbitrarily high. Furthermore, for a certain network structure, the price of anarchy is bounded by a multiple of the price of stability.

**Theorem 5** *Given  $M \in \mathbb{R}$  such that  $M > 1$ , there exists an instance  $G$  of the PFSCWP where  $PS = M$  and  $PA = 7M/6$ .*

*Proof.* Consider an instance  $G$  of the PFSCWP with three players denoted  $i_1, i_2, i_3$  and three facilities denoted  $j_1, j_2, j_3$ . Let  $d_{i_1 j_1} = d_{i_2 j_2} = d_{i_3 j_3} = 0$ ,  $d_{i_1 j_2} = d_{i_2 j_3} = d_{i_3 j_1} = M - 1$ ,  $d_{i_1 j_3} = d_{i_2 j_1} = d_{i_3 j_2} = 7M/6 - 1$ . Let  $\alpha_{i_k j_k} = 3M/2$  for  $k = 1, 2, 3$ ;  $\alpha_{i_1 j_2} = \alpha_{i_2 j_3} = \alpha_{i_3 j_1} = M/4$ ; and  $\alpha_{i_1 j_3} = \alpha_{i_2 j_1} = \alpha_{i_3 j_2} = M/3$ . The instance is illustrated in Figure 4.4.

The centralized optimum  $X^*$  assigns each player  $i_k$  to facility  $j_k$  obtaining the objective value  $Z(X^*) = 3$ . In  $X^*$ , the utility of each player is  $3M/2$ . This is not a Nash equilibrium because each player can decrease his utility by switching as follows: player  $i_1$  to facility  $j_2$ ,  $i_2$  to facility  $j_3$ , and  $i_3$  to facility  $j_1$ .

The solution  $X^1 = (2, 3, 1)$  is the least costly equilibrium with  $Z(X^1) = 3M$ . In  $X^1$ , the utility of each player is  $M/4 + (M - 1) = 5M/4 - 1$ . The solution  $X^2 = (3, 1, 2)$  is the only other equilibrium with  $Z(X^2) = 7M/2$ . In  $X^2$ , the utility of each player is  $3M/2 - 1$ .

In this instance  $PS = Z(X^1)/Z(X^*) = 3M/3 = M$  and  $PA = Z(X^2)/Z(X^*) = (7M/2)/3 = 7M/6$ . □

As Theorem 5 demonstrates, the cost of even the best possible equilibrium may be very expensive from the centralized planner's perspective. While this proof does not necessarily



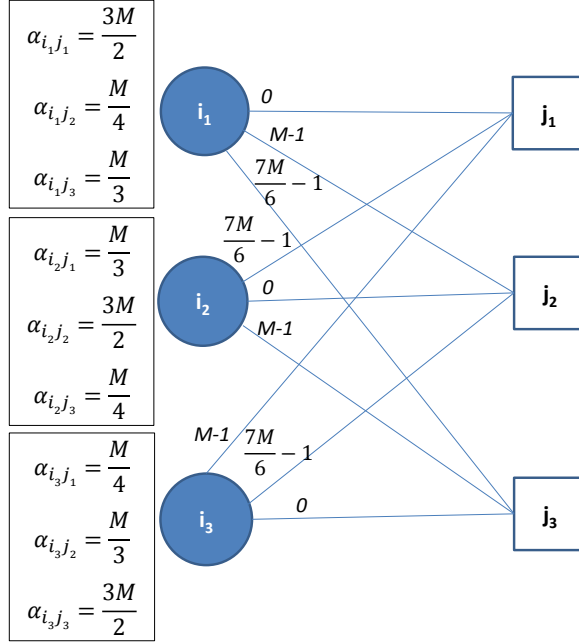

**Figure 4.4:** *Illustration of the network described in Theorem 5.*

imply a consistent relationship between the price of stability and the price of anarchy for the general case, the instance constructed in Theorem 5 illustrates that for some structures, the price of anarchy is bounded by a multiple of the price of stability.

In practice, an arbitrarily large price of stability signifies that self-interested decisions may be extremely costly, even in the best-case scenario. This result motivates the next section, in which the author identifies modifications to player utility functions so that individuals may choose what is best for the system.

#### 4.4.2 Coordination Mechanisms

In this section, the author explores coordination mechanisms for the PFSCWP. It is shown that any solution, including the centralized optimum, may be made an equilibrium with the correct assignment of congestion weights. In practice, if beneficiaries' utility functions can be altered, these systems may behave in a centrally optimal manner. This would ease congestion on certain facilities and preclude unnecessary travel. Player-facility-specific

congestion weights might be altered by distributing information to individuals regarding facility congestion levels, or by offering incentives to choose one facility over another such as transportation assistance. The first result in this section demonstrates that any solution, including a centralized optimum, to an instance of the PFSCWP can be made into an equilibrium by applying appropriate congestion weights.

**Theorem 6** *Given an instance  $G$  of the PFSCWP with solution  $X$ , there exist values  $\alpha_{ij} \geq 0$  for all  $i \in N$  and  $j \in F$  for which  $X$  is a Nash equilibrium.*

*Proof.* Consider an instance  $G$  of the PFSCWP and an arbitrary solution  $X$  in which player  $i$  chooses facility  $j$ . Let  $x_k$  be the number of players assigned to facility  $k$  for all  $k \in F$ . Given any initial value for  $\alpha_{ij}$ , the following assignment of  $\alpha_{ik}$  for all  $k \neq j \in F$  will satisfy the equilibrium condition for player  $i$  in  $X$ .

For each facility  $k \neq j$ , there are two cases:

- i.) If  $\alpha_{ij}x_j + d_{ij} \leq d_{ik}$ , assign  $\alpha_{ik} = \alpha_{ij}$ . The equilibrium condition for player  $i$  is satisfied since  $\alpha_{ij}x_j + d_{ij} \leq \alpha_{ij}(x_k + 1) + d_{ik}$  since  $\alpha_{ij} \geq 0$  and  $x_k \geq 0$ .
- ii.) If  $\alpha_{ij}x_j + d_{ij} > d_{ik}$ , assign  $\alpha_{ik} = (\alpha_{ij}x_j + d_{ij} - d_{ik})/(x_k + 1)$ .

To show that this satisfies the equilibrium condition, perform the following algebraic transformation:

1. Begin with the trivial inequality,  $\alpha_{ij}x_j + d_{ij} \leq \alpha_{ij}x_j + d_{ij}$ .
2. Add  $d_{ik} - d_{ik}$  to the right side, giving  $\alpha_{ij}x_j + d_{ij} \leq \alpha_{ij}x_j + d_{ij} + d_{ik} - d_{ik}$ .
3. Multiply the right side by  $(x_k + 1)/(x_k + 1)$  resulting in
$$\alpha_{ij}x_j + d_{ij} \leq \frac{(x_k+1)}{(x_k+1)}(\alpha_{ij}x_j + d_{ij} - d_{ik} + d_{ik}).$$
4. Rearrange terms to obtain
$$\alpha_{ij}x_j + d_{ij} \leq \left(\frac{\alpha_{ij}x_j + d_{ij} - d_{ik}}{x_k + 1}\right)(x_k + 1) + d_{ik}.$$

The last inequality is the equilibrium condition for player  $i$  with the proposed value of  $\alpha_{ik}$ .

Assigning congestion weights in this way ensures that the equilibrium condition is satisfied for player  $i$  at his chosen facility  $j$  and all other facilities  $k$ . Applying this technique for all players will induce equilibrium on  $X$ .  $\square$

Theorem 6 demonstrates that there exist congestion weights for any solution  $X$  that make it an equilibrium. If  $X$  is a centralized optimum, these congestion weights coordinate the decentralized system so that individual decision makers have no incentive to deviate from the system-optimal solution.

## 4.5 Analysis of the PSCWP

This section introduces the PSCWP, a special case of the PFSCWP where the utility of player  $i$  at chosen facility  $j$  is given by  $u_{ij}(x_j) = \alpha_i x_j + d_{ij}$ . Now,  $\alpha_i$  is a player-specific congestion weight, signifying that each player places an individual weight on congestion but applies it identically at every facility. This type of utility function is practical when individuals feel that the quality of service is similar at all facilities and do not prefer one service provider over another. For this problem class, the author first provides a network-based algorithm for computing an equilibrium in polynomial time. Next, the author shows that there exist instances for which the prices of stability and anarchy may be arbitrarily expensive. However, the price of anarchy is bounded in terms of the least and greatest congestion weights over the set of players. Finally, the author explores coordination mechanisms, identifying equilibrium-obtaining  $\alpha_i$  values for a given centralized optimum.

### 4.5.1 Complexity of Computing an Equilibrium Solution

It has been shown that an equilibrium exists for every instance of the PSCWP and that computing an equilibrium can be done in polynomial time [135]. This section presents an

alternative algorithm based on the network structure. First, the network congestion game is transformed to a related minimum cost flow problem. The solution to the flow problem is a minimizer of an exact potential function, which corresponds to an equilibrium.

**Theorem 7** *An equilibrium solution to an instance of the PSCWP can be computed in polynomial time using a transformation to a related minimum cost flow problem.*

*Proof.* For ease of exposition, it is assumed that  $\alpha_i > 0$  for all  $i \in N$ . This assumption will be relaxed later. Recall that the equilibrium condition for player  $i$  at chosen facility  $j$  is  $\alpha_i x_j + d_{ij} \leq \alpha_i(x_k + 1) + d_{ik}$  for all  $i \in N$  where  $k \neq j$ . Dividing both sides of the equilibrium condition for  $i$  by  $\alpha_i$  yields  $x_j + d_{ij}/\alpha_i \leq (x_k + 1) + d_{ik}/\alpha_i$ . Thus, computing an equilibrium with  $u_{ij}(x_j) = \alpha_i x_j + d_{ij}$  is equivalent to computing an equilibrium with  $u_{ij}(x_j) = x_j + d_{ij}/\alpha_i$ .

Modeling decentralized players with individual preferences begins with the centralized planner's network that is displayed in Figure 4.2(b) where each player allocates one unit of flow and the sink node  $t$  has  $n$  units of demand. Consider the following network transformation. Let the cost of the arc between player  $i$  and facility  $j$  be  $w_{ij} = d_{ij}/\alpha_i$ . For each arc  $(j, t)$ , create  $n$  copies, each with capacity 1. The cost of the  $k^{\text{th}}$  copy is  $k$  for  $k \in \{1, 2, \dots, n\}$  as illustrated in Figure 4.5. This transformation requires  $O(mn)$  effort.

It is now shown that an assignment of players to facilities is feasible if and only if it corresponds to a feasible flow in the transformed network. Consider a feasible assignment of players to facilities. This assignment is represented on the transformed network by allocating one unit of flow from each player to the assigned facility on a path to the sink node. The aggregate flow satisfies flow balance and capacity constraints.

Now, consider a feasible integer flow in the transformed network. Feasibility implies that one unit is supplied from each player and that  $n$  total units reach the sink node without violating arc capacities. An assignment of players to facilities is created by identifying the arcs  $(i, j)$  that have a flow of one. In this way, each player is assigned to exactly one facility, and the flow corresponds to a feasible assignment of players to facilities.

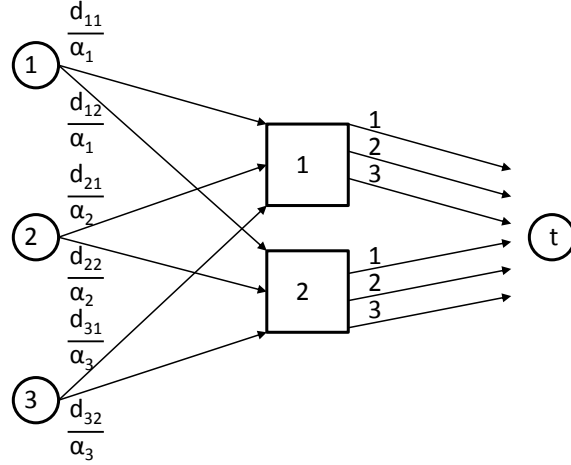

**Figure 4.5:** *The transformed network structure with  $n$  duplicate arcs from each facility to the sink node.*

The next step of the proof is to map the minimum cost flow in the transformed network to a Nash equilibrium for the original problem. This is done with a potential function. Let  $x_{ij}^s$  be the binary variable that indicates whether player  $i$  chooses facility  $j$  in solution  $s$  and  $x_j^s$  be the congestion of facility  $j$ . The potential function that establishes the result is

$$\phi(s) = \sum_{i=1}^n \sum_{j=1}^m \frac{d_{ij}}{\alpha_i} x_{ij}^s + \sum_{j=1}^m \sum_{y=1}^{x_j^s} y.$$

To show that this is an exact potential function, suppose player  $i$  switches from facility  $j$  in solution  $s$  to some facility  $k$ , creating solution  $s'$ . The change in  $i$ 's utility equals the change in the potential function value as shown below.

$$\begin{aligned} \phi(s) - \phi(s') &= \left( \sum_{i=1}^n \sum_{j=1}^m \frac{d_{ij}}{\alpha_i} x_{ij}^s + \sum_{j=1}^m \sum_{y=1}^{x_j^s} y \right) - \left( \sum_{i=1}^n \sum_{j=1}^m \frac{d_{ij}}{\alpha_i} x_{ij}^{s'} + \sum_{j=1}^m \sum_{y=1}^{x_j^{s'}} y \right) \\ &= \left( \frac{d_{ij}}{\alpha_i} + x_j^s \right) - \left( \frac{d_{ik}}{\alpha_i} + x_k^{s'} \right) \\ &= u_{ij}(x_j^s) - u_{ik}(x_k^{s'}). \end{aligned}$$

Thus, this is an exact potential function and solving the minimum cost flow problem on the transformed network minimizes  $\phi(s)$ . Potential function local minima correspond to Nash equilibrium solutions [133]. An optimal solution to the minimum cost flow problem is a global minimizer of the potential function and thus an equilibrium. The network transformation requires polynomial time and the minimum cost flow problem is polynomially-solvable. Therefore, computing a Nash equilibrium solution can be done in polynomial time using the transformation described.

Consider now the case when  $\alpha_i = 0$  for some player  $i$ . In this instance, player  $i$  places no weight on congestion and chooses a facility based only on distance. Thus, any equilibrium solution will require player  $i$  to be assigned to his closest facility. In order to create an equilibrium solution using the algorithm described above, the flow along the path involving all such players  $i$  and their closest facility must be set equal to one. The resulting flow problem for remaining players is then solved as described above.  $\square$

Theorem 7 demonstrates an efficient method for computing an equilibrium for the PSCWP.

**Corollary 2** *Infinite best-reply paths cannot occur in the PSCWP.*

*Proof.* The existence of a potential function implies that a game possesses the finite improvement property, which means that improving player-facility exchanges will lead to an equilibrium [136].  $\square$

As equilibria are the result of self-interested decisions, they represent probable outcomes. In practice, the ability to predict beneficiary decisions could support more accurate demand forecasts at each facility.

## 4.5.2 Bounds on Performance

In this section, the author analyzes outcomes of the PSCWP in terms of the centralized planner's objective function. Specifically, bounds on the price of anarchy are derived in

terms of the greatest and least congestion weights over the set of players. Finally, the author shows that the price of stability may be arbitrarily expensive.

#### 4.5.2.1 Bounds on Price of Anarchy

The proofs in this section cannot apply the techniques used for the PFSCWP where an equilibrium solution involves all beneficiaries choosing the same distant facility. Instead, the proofs utilize algebraic manipulation and a previously established inequality. The results in this section are illustrated in Table 4.2.

**Table 4.2:** *Performance bounds for the PSCWP.*

Criteria	PA Lower Bound	PA Upper Bound
$\alpha_i > 0, d_{ij} \geq 0$	$\frac{\alpha_{max} + \alpha_{min}}{2} + 1$ (Theorem 8)	$\frac{2.5(\alpha_{max} + 1)^2}{\alpha_{min}}$ (Theorem 8)
$\alpha_i \geq 1, d_{ij} \geq 0$	$\alpha_{max} + 1$ (Theorem 9)	$2.5\alpha_{max}$ (Theorem 9)

The author begins by deriving lower and upper bounds on the price of anarchy when  $\alpha_i > 0$  for all players  $i$ .

**Theorem 8** *When  $\alpha_i > 0$  for all  $i \in N$  and  $d_{ij} \geq 0$  for all  $i \in N$  and  $j \in F$ , the price of anarchy for the PSCWP satisfies  $(\alpha_{max} + \alpha_{min})/2 + 1 \leq PA \leq 2.5(\alpha_{max} + 1)^2/\alpha_{min}$ , where  $\alpha_{min}$  and  $\alpha_{max}$  are the least and greatest congestion weights over the set of players, respectively.*

*Proof.* The proof consists of two parts. First, an instance of the PSCWP is defined for which  $PA = (\alpha_{max} + \alpha_{min})/2 + 1$  to prove the lower bound. Next, an algebraic manipulation that applies the inequality found in [144] proves the upper bound.

To prove the lower bound, consider an instance with two players and two facilities. Let  $d_{12} = \alpha_{max}$ ,  $d_{21} = \alpha_{min}$ , and  $d_{11} = d_{22} = 0$ . In addition, let  $\alpha_1 = \alpha_{max}$  and  $\alpha_2 = \alpha_{min}$ .

The solution  $X = (2, 1)$  is the most expensive equilibrium with  $Z(X) = 2 + \alpha_{max} + \alpha_{min}$ . In this solution, the utility of player 1 is  $2\alpha_{max}$  and the utility of player 2 is  $2\alpha_{min}$ . If either player switched facilities, his utility would remain the same.

The solution  $X^* = (1, 2)$  is the centralized optimum. The total cost is  $Z(X^*) = 2$ . Thus, the price of anarchy for this instance is  $PA = (2 + \alpha_{max} + \alpha_{min})/2 = (\alpha_{max} + \alpha_{min})/2 + 1$ . The PA for the class of games must be at least the PA of this instance.

To establish the upper bound, let  $X$  be an equilibrium solution and  $X^*$  be a centralized optimum to an instance of the PSCWP. Let  $I(j)$  be the set of players at facility  $j$  in  $X$  and  $I^*(j)$  be the set of players at facility  $j$  in  $X^*$ , where  $|I(j)| = x_j$  and  $|I^*(j)| = x_j^*$ , respectively.

The proof will apply an inequality from [144], specifically

$$\sum_{j \in F} x_j^*(x_j + 1) + \sum_{j \in F} \sum_{i \in I^*(j)} d_{ij} \leq 2.5 \left( \sum_{j \in F} x_j^{*2} + \sum_{j \in F} \sum_{i \in I^*(j)} d_{ij} \right). \quad (4.1)$$

Since  $X$  is an equilibrium, it satisfies the equilibrium condition for each player. Thus,  $\alpha_i x_{j_i} + d_{ij_i} \leq \alpha_i (x_{j_i^*} + 1) + d_{ij_i^*}$ , where  $j_i$  is the facility that player  $i$  chooses in the equilibrium solution and  $j_i^*$  is the facility where  $i$  is assigned in the centralized optimum. Aggregating the equilibrium conditions over the set of players gives

$$\sum_{i \in N} (\alpha_i x_{j_i} + d_{ij_i}) \leq \sum_{i \in N} (\alpha_i (x_{j_i^*} + 1) + d_{ij_i^*}).$$

Regrouping by facilities yields

$$\sum_{j \in F} \sum_{i \in I(j)} (\alpha_i x_j + d_{ij}) \leq \sum_{j \in F} \sum_{i \in I^*(j)} (\alpha_i (x_j + 1) + d_{ij}),$$

and separating distance and congestion components gives

$$\sum_{j \in F} \sum_{i \in I(j)} \alpha_i x_j + \sum_{j \in F} \sum_{i \in I(j)} d_{ij} \leq \sum_{j \in F} \sum_{i \in I^*(j)} \alpha_i (x_j + 1) + \sum_{j \in F} \sum_{i \in I^*(j)} d_{ij}. \quad (4.2)$$



Focusing on the left side of (4.2), since  $\alpha_{min}$  is the lowest congestion weight over the set of players and  $|I(j)| = x_j$ ,

$$\alpha_{min} \sum_{j \in F} x_j^2 + \sum_{j \in F} \sum_{i \in I(j)} d_{ij} \leq \sum_{j \in F} \sum_{i \in I(j)} \alpha_i x_j + \sum_{j \in F} \sum_{i \in I(j)} d_{ij}. \quad (4.3)$$

Turning attention to the right side of (4.2), since  $\alpha_{max}$  is the greatest congestion weight over the set of players and  $|I^*(j)| = x_j^*$ ,

$$\sum_{j \in F} \sum_{i \in I^*(j)} \alpha_i (x_j + 1) + \sum_{j \in F} \sum_{i \in I^*(j)} d_{ij} \leq \alpha_{max} \sum_{j \in F} x_j^* (x_j + 1) + \sum_{j \in F} \sum_{i \in I^*(j)} d_{ij}. \quad (4.4)$$

Since  $\alpha_{max} + 1 > 1$ ,

$$\alpha_{max} \sum_{j \in F} x_j^* (x_j + 1) + \sum_{j \in F} \sum_{i \in I^*(j)} d_{ij} \leq (\alpha_{max} + 1) \left( \sum_{j \in F} x_j^* (x_j + 1) + \sum_{j \in F} \sum_{i \in I^*(j)} d_{ij} \right). \quad (4.5)$$

With respect to the left of (4.3), since  $\alpha_{max} + 1 > \alpha_{min}$  and  $\alpha_{min}/(\alpha_{max} + 1) \leq 1$ ,

$$\frac{\alpha_{min}}{\alpha_{max} + 1} \left( \sum_{j \in F} x_j^2 + \sum_{j \in F} \sum_{i \in I(j)} d_{ij} \right) \leq \alpha_{min} \sum_{j \in F} x_j^2 + \sum_{j \in F} \sum_{i \in I(j)} d_{ij}. \quad (4.6)$$

Combining (4.4), (4.5), and (4.6) gives

$$\frac{\alpha_{min}}{\alpha_{max} + 1} \left( \sum_{j \in F} x_j^2 + \sum_{j \in F} \sum_{i \in I(j)} d_{ij} \right) \leq (\alpha_{max} + 1) \left( \sum_{j \in F} x_j^* (x_j + 1) + \sum_{j \in F} \sum_{i \in I^*(j)} d_{ij} \right). \quad (4.7)$$

The expression in parentheses on the farthest right of (4.7) is equivalent to the expression on the left of (4.1). Thus,

$$\frac{\alpha_{min}}{\alpha_{max} + 1} \left( \sum_{j \in F} x_j^2 + \sum_{j \in F} \sum_{i \in I(j)} d_{ij} \right) \leq 2.5(\alpha_{max} + 1) \left( \sum_{j \in F} x_j^{*2} + \sum_{j \in F} \sum_{i \in I^*(j)} d_{ij} \right),$$

which implies that

$$\sum_{j \in F} x_j^2 + \sum_{j \in F} \sum_{i \in I(j)} d_{ij} \leq \frac{2.5(\alpha_{max} + 1)^2}{\alpha_{min}} \left( \sum_{j \in F} x_j^{*2} + \sum_{j \in F} \sum_{i \in I^*(j)} d_{ij} \right).$$

Therefore,  $PA \leq 2.5(\alpha_{max} + 1)^2/\alpha_{min}$ . □

Theorem 8 demonstrates that when  $\alpha_{max}$  is large compared to  $\alpha_{min}$ , the price of anarchy may be high. In practice, poor outcomes may result when some beneficiaries place a low weight on congestion while others place one that is high. In fact, as this ratio grows, so does the bound on the cost of the worst outcome.

**Corollary 3** *When  $\alpha_i > 0$  for all  $i \in N$  and  $d_{ij} \geq 0$  for all  $i \in N$  and  $j \in F$ , the price of anarchy for the PSCWP satisfies  $PA \leq 2.5(\alpha_{max} + 1)^2/\alpha_{min}$ , where  $\alpha_{min}$  and  $\alpha_{max}$  are the least and greatest congestion weights over the set of players and facilities, respectively.*

*Proof.* The proof of the upper bound follows identically to that in Theorem 8 where  $\alpha_{min}$  is the least  $\alpha_{ij}$  and  $\alpha_{max}$  is the greatest  $\alpha_{ij}$  value over the set of players and facilities, respectively. □

The author now investigates a more restricted congestion game that requires  $\alpha_i \geq 1$  for all  $i \in N$ . This models the situation in which congestion is at least as important to the beneficiaries as it is to the centralized planner. In this case, tighter lower and upper bounds on the price of anarchy are found, both of which are functions of  $\alpha_{max}$ .

**Theorem 9** *When  $\alpha_i \geq 1$  for all  $i \in N$  and  $d_{ij} \geq 0$  for all  $i \in N$  and  $j \in F$ , the price of anarchy for the PSCWP satisfies  $\alpha_{max} + 1 \leq PA \leq 2.5\alpha_{max}$ , where  $\alpha_{max}$  is the greatest congestion weight over the set of players.*

*Proof.* The lower bound is proven similarly to [1] by providing a network structure that achieves the bound at equality. Consider an instance of the PSCWP with  $n$  players denoted  $i_1, i_2, \dots, i_n$  and  $m$  facilities denoted  $j_1, j_2, \dots, j_m$ . Let  $\alpha_{i_k} = \alpha_{max}$  for all  $i_k \in N$ . Let  $d_{i_k j_1} = 0$

for all  $i_k \in N$  and  $j_l \in F$  such that  $k = l$ ; let  $d_{i_k j_l} = \alpha_{max}$  for all  $i_k \in N$  and  $j_l \in F$  such that  $k \neq l$ .

The centralized optimum  $X^*$  assigns each player  $i_k$  to facility  $j_k$ , obtaining a total cost equal to  $n$ . In  $X^*$ , the utility of each player is  $\alpha_{max}$ . This is an equilibrium because if a player switched to another facility, his utility would increase to  $3\alpha_{max}$ .

Equilibrium solutions also exist where each player  $i_k$  chooses a facility  $j_l$  where  $k \neq l$ , and each facility is chosen by exactly one player. In these solutions, the utility of each player is  $2\alpha_{max}$ . If a player  $i_k$  switched to facility  $j_k$ , his utility would remain  $2\alpha_{max}$ . If the player switched to another facility  $j_l \neq j_k$ , his utility would increase to  $3\alpha_{max}$ . The total cost for each of these equilibria is  $n + n\alpha_{max}$ . These equilibria and the centralized optimum are the only equilibria for this game because no equilibrium will involve two or more players at a single facility. Therefore, the price of anarchy for this instance equals  $(n\alpha_{max} + n)/n = \alpha_{max} + 1$ , which implies the price of anarchy for the entire class of games must be at least as much.

To establish the upper bound, consider an instance of the PSCWP. Let  $j_i$  be the facility that player  $i$  chooses in the equilibrium solution and  $j_i^*$  be the facility to which  $i$  is assigned in the centralized optimum. Let  $d_{ij_i}$  be the distance from player  $i$  to facility  $j_i$  and  $\alpha_i$  be the weight that player  $i$  places on congestion at all facilities. Let  $X$  be an equilibrium solution and  $X^*$  be the centralized optimum. Let  $I(j)$  be the set of players at facility  $j$  in  $X$  and  $I^*(j)$  be the set of players at facility  $j$  in  $X^*$ , where  $|I(j)| = x_j$  and  $|I^*(j)| = x_j^*$ , respectively. This proof will again apply the inequality from [144].

Since  $X$  is an equilibrium, it satisfies the equilibrium condition for each player  $i$ . Thus,  $\alpha_i x_{j_i} + d_{ij_i} \leq \alpha_i (x_{j_i^*} + 1) + d_{ij_i^*}$ . Dividing both sides of the equilibrium condition by  $\alpha_i$  yields  $x_{j_i} + d_{ij_i}/\alpha_i \leq (x_{j_i^*} + 1) + d_{ij_i^*}/\alpha_i$ . Aggregating this expression over all players gives

$$\sum_{i \in N} \left( x_{j_i} + \frac{d_{ij_i}}{\alpha_i} \right) \leq \sum_{i \in N} \left( x_{j_i^*} + 1 + \frac{d_{ij_i^*}}{\alpha_i} \right). \quad (4.8)$$

Regrouping by facilities yields

$$\sum_{j \in F} \sum_{i \in I(j)} \left( x_j + \frac{d_{ij}}{\alpha_i} \right) \leq \sum_{j \in F} \sum_{i \in I^*(j)} \left( x_j + 1 + \frac{d_{ij^*}}{\alpha_i} \right) \quad (4.9)$$

and simplifying gives

$$\sum_{j \in F} x_j^2 + \sum_{j \in F} \sum_{i \in I(j)} \frac{d_{ij}}{\alpha_i} \leq \sum_{j \in F} x_j^*(x_j + 1) + \sum_{j \in F} \sum_{i \in I^*(j)} \frac{d_{ij}}{\alpha_i}. \quad (4.10)$$

With respect to the left side of (4.10), since  $\alpha_{max} \geq 1$ ,

$$\frac{1}{\alpha_{max}} \left( \sum_{j \in F} x_j^2 + \sum_{j \in F} \sum_{i \in I(j)} d_{ij} \right) \leq \sum_{j \in F} x_j^2 + \sum_{j \in F} \sum_{i \in I(j)} \frac{d_{ij}}{\alpha_i}. \quad (4.11)$$

Turning attention to the expression on the right of (4.10), and again applying the fact that  $\alpha_i \geq 1$  for all players  $i$ ,

$$\sum_{j \in F} x_j^*(x_j + 1) + \sum_{j \in F} \sum_{i \in I^*(j)} \frac{d_{ij}}{\alpha_i} \leq \sum_{j \in F} x_j^*(x_j + 1) + \sum_{j \in F} \sum_{i \in I^*(j)} d_{ij}. \quad (4.12)$$

The expression on the right of (4.12) is equal to that on the left of (4.1). Combining relationships (4.1), (4.11), and (4.12) gives

$$\frac{1}{\alpha_{max}} \left( \sum_{j \in F} x_j^2 + \sum_{j \in F} \sum_{i \in I(j)} d_{ij} \right) \leq 2.5 \left( \sum_{j \in F} x_j^{*2} + \sum_{j \in F} \sum_{i \in I^*(j)} d_{ij} \right)$$

and therefore,

$$\sum_{j \in F} x_j^2 + \sum_{j \in F} \sum_{i \in I(j)} d_{ij} \leq 2.5 \alpha_{max} \left( \sum_{j \in F} x_j^{*2} + \sum_{j \in F} \sum_{i \in I^*(j)} d_{ij} \right).$$

The expression on the left is the total cost of the equilibrium while the expression in parentheses on the right is the total cost of the centralized optimum. Therefore, the total

cost of the equilibrium solution is no more than  $2.5\alpha_{max}$  times the total cost of the centralized optimum and the price of anarchy is at most  $2.5\alpha_{max}$ .  $\square$

It follows that when  $\alpha_i = 1$  for all  $i \in N$ , the price of anarchy satisfies  $2 \leq PA \leq 2.5$ , a finding verified in [1]. In practice, since the bound in Theorem 9 increases as  $\alpha_{max}$  increases, decentralized systems with at least one individual who places a very high weight on congestion can be very costly.

**Corollary 4** *When  $\alpha_i \geq 1$  for all  $i \in N$  and  $d_{ij} \geq 0$  for all  $i \in N$  and  $j \in F$ , the price of anarchy satisfies  $\alpha_{max} + 1 \leq PA \leq 2.5\alpha_{max}$ , where  $\alpha_{max}$  is the greatest congestion weight over the set of players.*

*Proof.* The proofs of both the lower and upper bounds follow identically to that in Theorem 8 where  $\alpha_{min}$  is the lowest  $\alpha_{ij}$  and  $\alpha_{max}$  is the greatest  $\alpha_{ij}$  value over the set of players and facilities, respectively.  $\square$

In summary, this section shows that the price of anarchy is bounded above and below by a function of  $\alpha_{min}$  and  $\alpha_{max}$  both when  $\alpha_i > 0$  and in the more restrictive case when  $\alpha_i \geq 1$  for all players  $i$ .

#### 4.5.2.2 Bounds on Price of Stability

Having demonstrated that the worst-case equilibrium can be costly, the author now investigates bounds on the price of stability for the PSCWP. The first result demonstrates that even the best possible equilibrium can be arbitrarily expensive.

**Theorem 10** *Given  $M \in \mathbb{R}$  such that  $M > 1$ , there exists an instance  $G$  of the PSCWP where  $PS = M$ .*

*Proof.* Consider an instance  $G$  of the PSCWP with two players denoted 1 and 2 and three facilities denoted 0, 1, and 2. For any  $M \in \mathbb{R}$  such that  $M > 1$ , let  $\alpha_1 = 4M - 1$ ,  $\alpha_2 = 5M + 1$ , and distances be those illustrated in Figure 4.6. Table 4.3 presents all possible outcomes

**Table 4.3:** Outcomes of the instance described in Theorem 10.

	Facility	Player 2		
		0	1	2
Player 1	0	$(8M-2, 10M+2)$ $Z(X^*) = 4$	$(4M-1, 4M-1)$ $Z=6M+2$	$(4M-1, 10M+1)$ $Z(X^2) = 5M + 2$
	1	$(8M-3, 5M+1)$ $Z(X^1) = 4M$	$(12M-4, 16M+2)$ $Z=10M+2$	$(8M-3, 10M+1)$ $Z=9M$
	2	$(10M-1, 5M+1)$ $Z=6M+2$	$(10M-1, 11M+1)$ $Z=12M+2$	$(12M-2, 15M+1)$ $Z=11M+4$

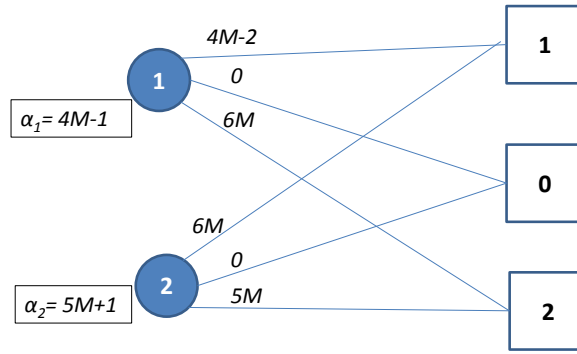

**Figure 4.6:** Illustration of network described in Theorem 10.

of the instance, where the row player is player 1 and the column player is player 2. Player utilities are presented in the form of  $(u_{1j}, u_{2k})$ , where  $j$  and  $k$  are the facility choices of players 1 and 2, respectively. The centralized cost  $Z$  is also shown.

The centralized optimum  $X^*$  assigns both players to facility 0, obtaining the objective value  $Z(X^*) = 4$ . The solutions  $X^1 = (1, 0)$  and  $X^2 = (0, 2)$  are the only equilibria with  $Z(X^1) = 4M$  and  $Z(X^2) = 5M + 2$ .

Since  $Z(X^1) < Z(X^2)$ ,  $PS = Z^1/Z^* = 4M/4 = M$ . □

Theorem 10 demonstrates through a small instance of the PSCWP that even the best decentralized decisions can be expensive for the overall system. This motivates the search

for mechanisms to coordinate decentralized systems.

### 4.5.3 Coordination Mechanisms and Effects of Player-Facility Exchanges

This section focuses on the relationship between a player's utility function and the centralized planner's objective function. Instances of the PSCWP are characterized for which there exist  $\alpha_i$  values that make the centralized optimum an equilibrium. Finally, the author investigates the impact of an individual altering his choice of facility on the centralized objective, identifying circumstances when such moves increase or decrease the performance of the overall system.

In the context of the PSCWP in particular, the weight that a player places on congestion (and implicitly on distance traveled) may be altered using incentives. For instance, if transportation assistance is offered, an individual's weight on congestion may decrease because distance is no longer an obstacle. In this way, individuals may be more satisfied by choosing an under-utilized, distant facility instead of a congested facility nearby, easing the burden on the system.

**Theorem 11** *Given any instance  $G$  of the PSCWP and a centralized optimum  $X^*$ , the congestion weight  $\alpha_i = 2$  for all  $i \in N$  will make  $X^*$  a Nash equilibrium.*

*Proof.* The desired result is obtained by examining the effect of an arbitrary player switching facilities on the centralized planner's objective function. Suppose player  $i$  is assigned to facility  $j$  in a centralized optimum  $X^*$ . Let  $I^*(j)$  be the set of players assigned to facility  $j$  in  $X^*$ . The centralized planner's objective function is given below with terms relevant to player  $i$  isolated:

$$Z(X^*) = \sum_{l \neq j \in F} x_l^2 + \sum_{l \in F} \sum_{p \neq i \in I^*(l)} d_{pl} + x_j^2 + d_{ij}.$$

Let  $X'$  be the solution obtained when player  $i$  switches from facility  $j$  to facility  $k$ . Then,

$$Z(X') = \sum_{l \neq j, k \in F} x_l^2 + \sum_{l \in F} \sum_{p \neq i \in I^*(l)} d_{pl} + (x_j - 1)^2 + (x_k + 1)^2 + d_{ik}$$

From the optimality of  $X^*$ ,  $Z(X^*) \leq Z(X')$ , which implies

$$\sum_{l \neq j, k \in F} x_l^2 + \sum_{l \in F} \sum_{p \neq i \in I^*(l)} d_{pl} + x_j^2 + x_k^2 + d_{ij} \leq \sum_{l \neq j, k \in F} x_l^2 + \sum_{l \in F} \sum_{p \neq i \in I^*(l)} d_{pl} + (x_j - 1)^2 + (x_k + 1)^2 + d_{ik}.$$

By subtraction,  $x_j^2 + x_k^2 + d_{ij} \leq (x_j - 1)^2 + (x_k + 1)^2 + d_{ik}$ , which simplifies to  $2x_j + d_{ij} \leq 2(x_k + 1) + d_{ik}$ .

The final inequality is the equilibrium condition for player  $i$  when  $\alpha_i = 2$ , indicating that  $i$  will prefer the centralized optimal assignment to facility  $j$  over alternative facility  $k$  when his congestion weight is 2. Since player  $i$  and facility  $k$  were chosen arbitrarily,  $\alpha_i = 2$  for all  $i \in N$  will ensure  $X^*$  is an equilibrium.  $\square$

Theorem 11 demonstrates that for a given centralized optimum, there exists at least one congestion weight value that will induce equilibrium. Specifically, if all players place exactly twice as much weight on congestion as they do on distance, decentralized players will have no incentive to deviate from the centralized optimum. In the next theorem, the author characterizes other equilibrium obtaining  $\alpha_i$  values.

**Theorem 12** *Let  $G$  be an instance of the PSCWP and  $X^*$  be a central optimum where player  $i$  is assigned to facility  $j$ . Let  $\alpha_i'' = \max_{m \in F: x_j < x_m \text{ and } d_{im} < d_{ij}} \{(d_{im} - d_{ij}) / (x_j - x_m - 1)\}$  for all facilities  $m$  that are more congested but closer to player  $i$  than  $j$  and  $\alpha_i' = \min_{l \in F: x_l + 1 < x_j \text{ and } d_{il} < d_{ij}} \{(d_{il} - d_{ij}) / (x_j - x_l - 1)\}$  for all facilities  $l$  that are less congested but further from player  $i$  than  $j$ . Any  $\alpha_i$  such that  $\alpha_i'' \leq \alpha_i \leq \alpha_i'$  will satisfy player  $i$ 's equilibrium condition in  $X^*$ . A set of such congestion weights for all  $i \in N$  will make  $X^*$  a Nash equilibrium.*



*Proof.* Consider an instance  $G$  of the PSCWP and let  $X^*$  be a centralized optimum in which player  $i$  chooses some facility  $j$ . Since  $X^*$  is a centralized optimum, there does not exist a facility that is both less congested and closer to  $i$  than  $j$ . However, there may exist facilities  $l$  or  $m$  where facility  $l$  is less congested but further than  $j$  and facility  $m$  that is more congested but closer than  $j$ . Mathematically, it may be that  $x_l < x_j < x_m$  and  $d_{im} < d_{ij} < d_{il}$ .

First, consider any facility  $m$  such that  $x_j < x_m$ , and  $d_{im} < d_{ij}$ . Player  $i$ 's equilibrium condition with respect to  $j$  and  $m$  is  $\alpha_i x_j + d_{ij} \leq \alpha_i (x_m + 1) + d_{im}$ . Player  $i$  is indifferent between facilities  $j$  and  $m$  when  $\alpha_i = \alpha_i^{m''} = (d_{im} - d_{ij}) / (x_j - x_m - 1)$ . Furthermore, his equilibrium condition is satisfied with respect to these two facilities for every  $\alpha_i \geq \alpha_i^{m''}$ .

Second, consider any facility  $l$  such that  $x_l + 1 < x_j$  and  $d_{ij} < d_{il}$ . Player  $i$ 's equilibrium condition with respect to facilities  $j$  and  $l$  is  $\alpha_i x_j + d_{ij} \leq \alpha_i (x_l + 1) + d_{il}$ . Player  $i$  is indifferent between facilities  $j$  and  $l$  when  $\alpha_i = \alpha_i^{l''} = (d_{il} - d_{ij}) / (x_j - x_l - 1)$ . Furthermore, his equilibrium condition is satisfied with respect to these two facilities for every  $\alpha_i \geq \alpha_i^{l''}$ .

Third, consider any facility  $l$  such that  $x_l = x_j + 1$  and  $d_{ij} < d_{il}$ . Note that any value of  $\alpha_i$  will satisfy player  $i$ 's equilibrium condition with respect to facilities  $j$  and  $l$ .

Finally, let  $\alpha_i'' = \max_{m \in F: x_j < x_m \text{ and } d_{im} < d_{ij}} \{\alpha_i^{m''}\}$  and  $\alpha_i' = \min_{l \in F: x_l + 1 < x_j \text{ and } d_{ij} < d_{il}} \{\alpha_i^{l''}\}$ . Then any  $\alpha_i$  such that  $\alpha_i'' \leq \alpha_i \leq \alpha_i'$  will satisfy the equilibrium condition for player  $i$  with respect to all facilities. The application of such  $\alpha_i$  values for all players will make  $X^*$  an equilibrium.  $\square$

To serve as an example of the concept demonstrated in Theorem 12, consider a problem with 15 players and 3 facilities. Suppose player  $i$  is assigned to facility  $j$  in the centralized optimum  $X^*$ , with  $x_j = 5$  and  $d_{ij} = 4$ . Consider facilities  $l$  and  $m$  where  $x_l = 3$ ,  $d_{il} = 8$ ,  $x_m = 7$ , and  $d_{im} = 1$ . For this solution to satisfy the equilibrium condition for player  $i$ , it must be that  $5\alpha_i + 4 \leq (3 + 1)\alpha_i + 8$  and  $5\alpha_i + 4 \leq (7 + 1)\alpha_i + 1$ . These two inequalities are both satisfied when  $1 \leq \alpha_i \leq 4$ . Thus, any value of  $\alpha_i$  in this range will ensure that player  $i$ 's equilibrium condition is satisfied in solution  $X^*$ . Note that the result of Theorem 11 implies the value two will always be in this range.

This result demonstrates there may exist a range of  $\alpha_i$  values below and above 2 that transform a centralized optimum into an equilibrium for player  $i$ . However, there do exist non-optimal solutions for which there is no  $\alpha_i$  value that induces equilibrium. Consider an instance where a player is choosing between a very far, very congested facility and a nearby, empty one. There is no non-negative congestion weight that would make the player prefer the distant facility over the one nearby. This result is in contrast to chapter 4.4 regarding the PFSCWP and to the findings in [1], which considers facility-specific congestion weights and finds that any solution can be made into an equilibrium.

The author now identifies conditions under which a player's self-interested move may increase or decrease the centralized planner's objective. It is valuable to identify these moves so that the corresponding players might be incentivized to make choices that improve the system as a whole.

**Theorem 13** *Let  $G$  be an instance of the PSCWP with solutions  $X$  and  $X'$ , where the only difference between the two is that player  $i$  chooses facility  $j$  in  $X$  and chooses facility  $k$  in  $X'$ . Player  $i$ 's utility is lower in  $X'$ . Then,  $Z(X') < Z(X)$  if one of the following conditions holds: (1)  $-2 + d_{ij} - d_{ik} > 0$ , (2)  $-2 + 2x_j - 2x_k > 0$ , or (3) if  $x_k < x_j$  and  $d_{ik} < d_{ij}$ .*

*Proof.* Given  $G$ ,  $X$ , and  $X'$  as in the theorem statement, let  $I(j)$  be the set of players assigned to facility  $j$ , and let  $x_j$  and  $x_k$  be the number of players at facilities  $j$  and  $k$ , respectively in  $X$ .

$$\text{Then } Z(X) = \sum_{l \neq j, k \in F} x_l^2 + \sum_{l \in F} \sum_{p \neq i \in I(l)} d_{pl} + (x_j)^2 + (x_k)^2 + d_{ij}$$

$$\text{and } Z(X') = \sum_{l \neq j, k \in F} x_l^2 + \sum_{l \in F} \sum_{p \neq i \in I(l)} d_{pl} + (x_j - 1)^2 + (x_k + 1)^2 + d_{ik}.$$

The difference in the centralized planner's objective function is given by

$$\begin{aligned}
Z(X) - Z(X') &= x_j^2 + x_k^2 + d_{ij} - (x_j - 1)^2 - (x_k + 1)^2 - d_{ik} \\
&= 2x_j - 2x_k - 2 + d_{ij} - d_{ik} \\
&= 2(x_j - x_k - 1) + d_{ij} - d_{ik}.
\end{aligned}$$

Since player  $i$ 's utility is lower in  $X'$ ,  $\alpha_i(x_k + 1) + d_{ik} < \alpha_i x_j + d_{ij}$ . There are three possible cases:

1.  $\alpha_i x_k < \alpha_i x_j$ , which implies  $x_k < x_j$
2.  $d_{ik} < d_{ij}$
3. Both  $x_k < x_j$  and  $d_{ik} < d_{ij}$

**Case 1:**  $\alpha_i x_k < \alpha_i x_j \rightarrow x_k < x_j$

Using substitution,  $Z(X) - Z(X') = 2(x_j - x_k - 1) + d_{ij} - d_{ik} > 2(x_j - x_j - 1) + d_{ij} - d_{ik} = -2 + d_{ij} - d_{ik}$ . Thus, if  $-2 + d_{ij} - d_{ik} > 0$ , the self-interested move improves the centralized planner's objective value.

**Case 2:**  $d_{ik} < d_{ij}$

Using substitution,  $Z(X) - Z(X') = 2(x_j - x_k - 1) + d_{ij} - d_{ik} > 2(x_j - x_k - 1) + d_{ij} - d_{ij} = -2 + 2x_j - 2x_k$ . Thus, if  $-2 + 2x_j - 2x_k > 0$ , the self-interested move improves the central planner's objective value.

**Case 3:** Both  $x_k < x_j$  and  $d_{ik} < d_{ij}$

This case must improve the centralized planner's objective because the player's move decreases both components of the objective function.  $\square$

Theorem 13 illustrates the underlying balance between the congestion and distance components of a player's utility. If a player places a very low weight on congestion, he may move

to a more crowded facility to travel a shorter distance. If the facility to which he moves is too congested, the shortened distance is overwhelmed by the congestion increase for the centralized planner. Conversely, if congestion is emphasized too greatly, a player may be willing to travel very far to receive service at a less congested facility. Both can be detrimental from a centralized perspective.

The next theorem identifies conditions under which a self-interested move increases the centralized planner's objective function value.

**Theorem 14** *Let  $G$  be an instance of the PSCWP with solutions  $X$  and  $X'$ , where the only difference is that player  $i$  chooses facility  $j$  in  $X$  and chooses facility  $k$  in  $X'$ . Player  $i$ 's utility is lower in  $X'$ . Then  $Z(X) < Z(X')$  if  $(d_{ij} - d_{ik} - 2)/2 < x_k - x_j < (d_{ij} - d_{ik} - \alpha_i)/\alpha_i$ .*

*Proof.* Given  $G$ ,  $X$ , and  $X'$  as in the theorem statement, let  $x_j$  and  $x_k$  be the congestion at facilities  $j$  and  $k$ , respectively, in  $X$ . Since  $i$ 's utility is lower in  $X'$ ,  $\alpha_i(x_k + 1) + d_{ik} < \alpha_i x_j + d_{ij}$ . Rearranging terms in the equilibrium condition gives  $x_k - x_j + 1 < (d_{ij} - d_{ik})/\alpha_i$ .

For  $i$ 's move from  $j$  to  $k$  to increase the centralized planner's objective,  $(x_j - 1)^2 + (x_k + 1)^2 + d_{ik} > x_j^2 + x_k^2 + d_{ij}$  must hold. The difference in objective function values is equivalent to  $-2x_j + 1 + 2x_k + 1 > d_{ij} - d_{ik}$ . Rearranging terms gives  $x_k - x_j + 1 > (d_{ij} - d_{ik})/2$ .

The expression  $x_k - x_j + 1$  appears in both the rearranged equilibrium condition and in the objective function inequality. Combining these two inequalities,  $(d_{ij} - d_{ik})/2 < x_k - x_j + 1 < (d_{ij} - d_{ik})/\alpha_i$ . Finally, subtracting 1 from all three parts of the inequality yields  $(d_{ij} - d_{ik} - 2)/2 < x_k - x_j < (d_{ij} - d_{ik} - \alpha_i)/\alpha_i$ .  $\square$

It is important to note that the final pair of inequalities in the proof is impossible to satisfy if  $\alpha_i = 2$  because the right and left sides are equal. This shows that when  $\alpha_i = 2$ , no move that strictly improves an individual's utility can strictly increase the centralized planner's objective function value.

## 4.6 Optimizing Coordination Mechanism Values

Results in the preceding sections demonstrate that coordination mechanisms exist. In practice, these congestion weights may be obtained through incentives such as transportation assistance or information dissemination in the form of pamphlets, signs, or social media notifications. For instance, if transportation were made available to take beneficiaries living in a densely populated area to under-utilized facilities in rural areas, congestion might be eased in the dense area and service made more efficient. For another example, if information regarding congestion and expected wait times were made available, beneficiaries could make better decisions for themselves and for the system. These incentives may modify beneficiaries' utilities for certain facilities so that they do not have incentive to deviate from a proposed centralized optimum.

However, changing individuals' utility functions through incentives incurs a cost. It is thus desirable to identify congestion weight values that can coordinate the system while minimizing relevant costs. In this section, the author introduces an optimization model to identify coordination mechanism values that optimize a particular cost function. The approach is demonstrated via a computational study using data from the 2010 cholera epidemic in Haiti.

### 4.6.1 Minimum Cost Coordination Mechanisms Model

Given input parameters to the centralized planner's problem, a centralized optimum  $X$ , and players' congestion weights  $\alpha_{ij}$  for all  $i \in N$  and  $j \in F$ , the Minimum Cost Coordination Mechanisms Model (MCCMM) identifies the modifications that must be made to individuals' congestion weights to transform  $X^*$  into an equilibrium at the lowest cost. In this problem, the optimal assignment of individuals to facilities is given by binary parameters  $x_{ij}$  for each  $i \in N$  and  $j \in F$ . Let  $I(j)$  be the set of players assigned to facility  $j$  in  $X$ , and let  $x_j = |I(j)|$ . The decision variables in the MCCMM are  $\alpha_{ij}^*$ , the new congestion

weight values that induce equilibrium.

The objective function minimizes the cumulative change required, where change is defined as the absolute value of the difference between the initial  $\alpha_{ij}$  value and  $\alpha_{ij}^*$  for all individuals  $i$  and facilities  $j$ . The difference between  $\alpha_{ij}$  and  $\alpha_{ij}^*$  represents the level of incentive required to obtain equilibrium. As incentives may be costly, it is desirable to obtain equilibrium using the least incentives possible. Mathematically, the MCCMM is defined by

$$\begin{aligned}
& \text{Minimize} && \sum_{i \in N} \sum_{j \in F} G_{ij} \\
& \text{subject to} && \\
& && G_{ij} \geq \alpha_{ij} - \alpha_{ij}^* \quad \forall i \in N, j \in F \\
& && G_{ij} \geq \alpha_{ij}^* - \alpha_{ij} \quad \forall i \in N, j \in F \\
& && \alpha_{ij}^* x_j + d_{ij} \leq \alpha_{ik}^* (x_k + 1) + d_{ik} \quad \forall j \in F, i \in I(j), k \neq j \in F \\
& && \alpha_{ij}^* \geq 0 \quad \forall i \in N, j \in F
\end{aligned}$$

The first two sets of constraints ensure that no matter if  $\alpha_{ij}^*$  is more or less than  $\alpha_{ij}$ , the change is counted as a positive number. This reflects the idea that increasing and decreasing congestion weights may be equally costly. The third set of constraints is the equilibrium condition with optimal congestion weights. Finally, the optimal congestion weights must be non-negative. Note that this is a linear program since the objective function and constraints are linear functions of the continuous decision variables  $\alpha_{ij}^*$ .

## 4.6.2 Computational Study and Results

The MCCMM is implemented using data from the cholera epidemic in Haiti described in Chapter 3. The study focuses on the Ouest department including Port-au-Prince, because

it is the most congested region of the country. First, the centralized planner's problem is solved to identify the assignment of demand to open facilities that minimizes system-wide distance and congestion. Then, the MCCMM is solved to compute congestion weights that will make the centralized optimum an equilibrium at minimum cost. In the remainder of this section, the author describes the study design and results.

#### 4.6.2.1 Study Design

Daily reports from [122] were analyzed and the mean daily number of cases in the department is used to represent the demand of an average day. The average daily demand in April 2011 was 62 individuals. The mean number of cases is distributed among 113 sections in the Ouest department in proportion to each section's population. Let  $D_s$  be the number of cases for section  $s$ .

Facility locations and capacities are taken from the robust solution prescribed in Chapter 3 of this dissertation, yielding 39 open facilities. Let  $C_j$  be the number of beds available at facility  $j$ . Figure 4.7 illustrates the spatial distribution of demand and available facilities over the study area. Darker shading indicates greater demand, where the greatest demand center lies in Port-au-Prince. As a result of the high density of demand, there are more facilities in this area. Conversely, facilities are more spread out in rural areas with lower demand.

Because cholera is deadly if not treated within a few hours and an average person can travel 5km per hour on foot [121], the maximum allowable distance between an individual and his assigned facility is 15km. Therefore, the centralized problem is modified such that the decision variable  $x_{ij}$  is only defined if individual  $i$  is within 15km of facility  $j$ .

Initial congestion weights are set to  $\alpha_{ij} = (10 * D_s)/C_j$  for individual  $i$  in section  $s$  and  $j \in F$ . The choice of  $\alpha_{ij}$  values stems from the idea that for a given demand, a person will choose a more distant facility that has a higher capacity over a closer facility if the number of other people at both facilities is the same. Similarly for a given facility capacity,

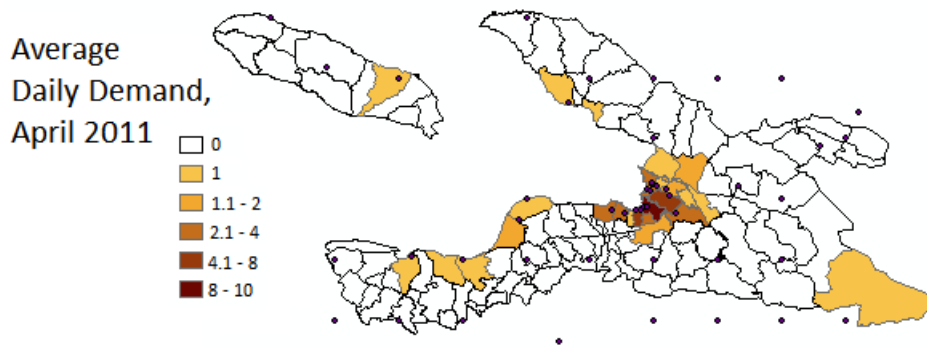

**Figure 4.7:** *Illustration of the average daily demand for each section in the Ouest department for April 2011. Dots represent the locations of open facilities within 15km of the Ouest department.*

a person may choose a more distant facility over one nearby if the demand of his section is high because proximal facilities may be overcrowded. The demand in the numerator is multiplied by 10 to make distance and congestion weights comparable. (Sensitivity analysis on the scaling factor yielded little change to overall conclusions.)

The centralized planner’s problem and the MCCMM are implemented using CPLEX 12.5 on a Dell XPS running Windows 7 with a 12-core processor and 64GB of memory. The centralized optimum was calculated in 1.03 seconds (212.30 ticks) and optimal congestion weights were computed in 0.09 seconds (32.43 ticks).

#### 4.6.2.2 The Centralized Optimum and Optimal Congestion Weights

Figures 4.8 and 4.9 illustrate the spatial distribution of the average distance traveled and congestion experienced in the centralized optimum for an individual in each section. Because of the spatial distribution of facilities, individuals in rural areas travel further than those in areas with higher demand. The greatest distance an individual must travel in the centralized optimum is 9.07km, well below the 15km threshold. Congestion is greater in areas of high demand, but the centralized optimum spreads people somewhat evenly across



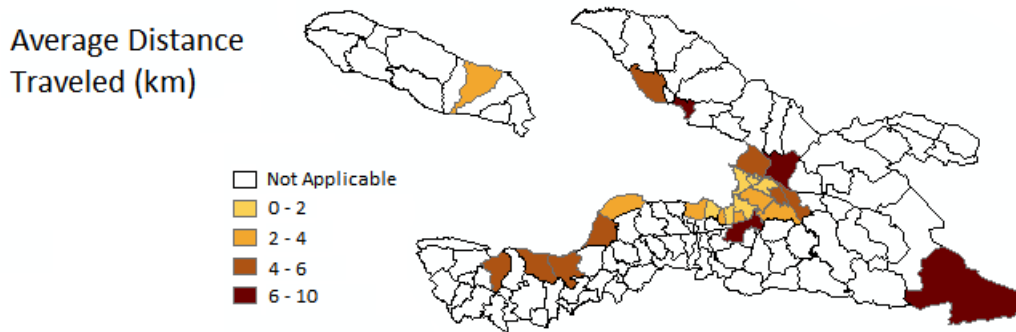
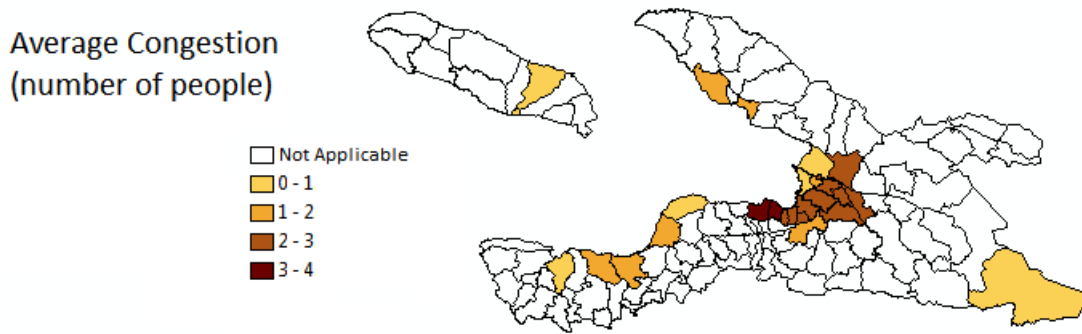

**Figure 4.8:** *The average distance traveled (km) to the assigned facility for each section.*

proximal facilities. The greatest congestion an individual experiences is 4 total people at an assigned facility.

The centralized optimum assigns 54 percent of the individuals to their nearest facility, demonstrating the potential inefficiency of models that assume all beneficiaries simply choose the nearest one. The total cost of assigning each person to his nearest facility would be 543.46, with 157.46km total distance traveled and a congestion cost of 386. By assigning some individuals to their second or third closest facility, the centralized optimum incurs a total cost of 334; total distance traveled increases to 176.45km but the congestion cost decreases to just 158. On average, an individual travels 0.31km further in the central optimum than to his nearest facility. In return, an individual experiences an average congestion of 1.6 people (including himself) instead of 2.1 if he had chosen the nearest facility.

The MCCMM decreases or increases initial congestion weights to encourage or discourage certain choices. Because the objective function seeks to minimize the cumulative change, an individual's congestion weight for his assigned facility will never be increased, and the congestion weight for unassigned facilities will never be decreased. Instead, the initial congestion weight for an assigned facility may need to be decreased to encourage the individual to choose that facility. Conversely, an individual's initial congestion weight for an unassigned facility may need to be increased so that the individual does not choose the facility.



**Figure 4.9:** *The average congestion experienced (number of people) at the assigned facility for each section.*

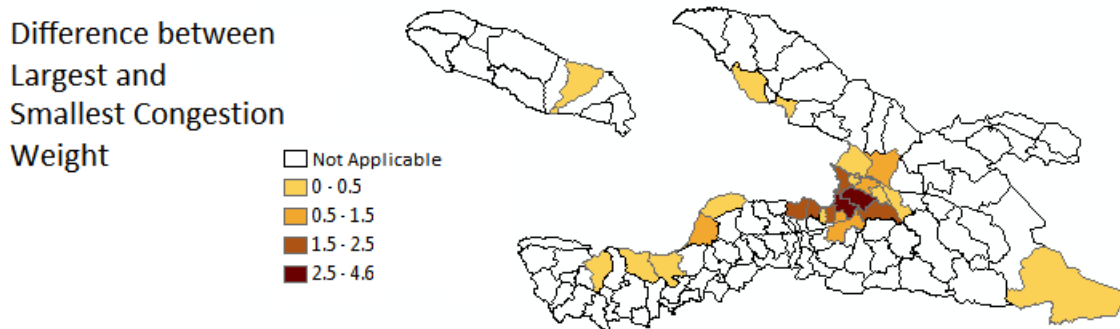
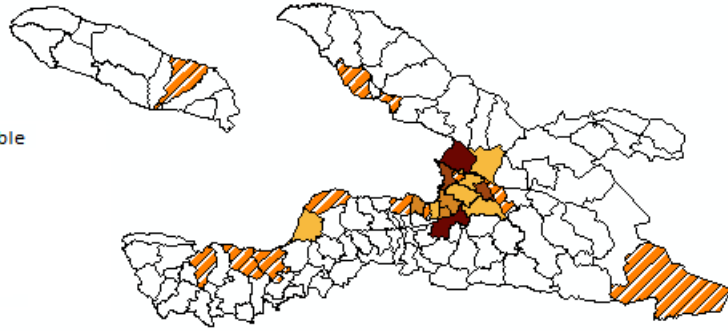
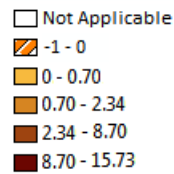

**Figure 4.10:** *The range in optimized congestion weights for each section.*

The range in optimal congestion weights and the average percentage change from initial to optimal is greatest in densely populated areas because this is where individuals had to be encouraged or discouraged from making certain choices. Figures 4.10 and 4.11 display this pattern. In practice, coordination mechanisms are likely to be most valuable in areas with over-congested facilities. The ability to spread people evenly among facilities will improve resource utilization as well as decrease the time an individual must wait to be served.

To better understand how results differ at the facility level, six facilities are examined in detail. These include two facilities with high capacities in dense areas (denoted HCD1 and HCD2), two facilities with low capacities in dense areas (denoted LCD1 and LCD2), one facility with high capacity in a rural area (HCR), and one facility with a low capacity in a

### Average Percent Change in Congestion Weights



**Figure 4.11:** *The average percentage change in congestion weight to obtain equilibrium for each section.*

rural area (LCR).

As Figure 4.12 indicates, no change in congestion weights is needed for facilities HCR and LCR. The rural location makes these facilities the only viable choice for individuals nearby. They are also too distant from individuals in densely populated areas to be considered either by a centralized planner or the beneficiaries themselves.

More interesting observations pertain to changes required for facilities in densely populated areas that have different capacities. Congestion weights for both HCD1 and HCD2 had to be increased on average, while congestion weights for LCD1 and LCD2 had to be decreased. Recall that facility capacity appears in the denominator of beneficiaries' initial congestion weights. If an individual is to feel similarly about a facility with high capacity and a facility with low capacity, the congestion weight for the high capacity facility must be increased and/or the congestion weight for the low capacity facility must be decreased. In practice, it may be imperative to encourage individuals to choose facilities with lower capacities so that facilities with greater capacities are not overwhelmed. Of course, this encouragement must not be so strong that low capacity facilities are overwhelmed themselves. The MCCMM balances these requirements.

Figures 4.13 through 4.18 display average initial congestion weights, optimized congestion weights, and the difference between them for each facility in the sample. The magnitude of

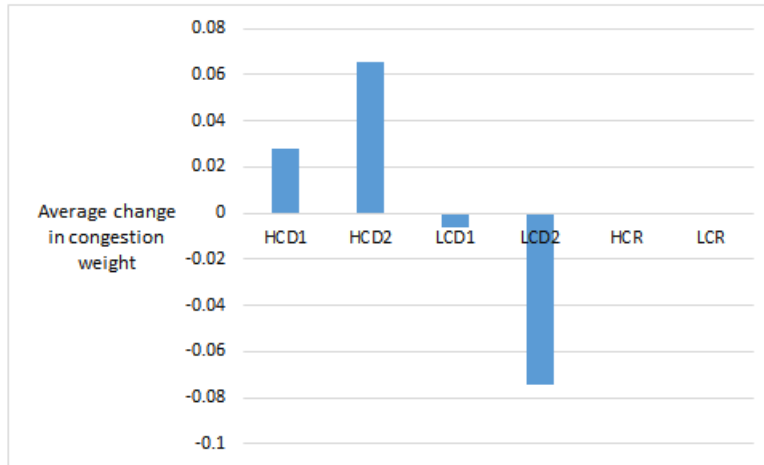

**Figure 4.12:** *The average required change in individuals' congestion weights for selected facilities of different types; HCD1 and HCD2 are high-capacity facilities in densely populated areas; LCD1 and LCD2 are two low-capacity facilities in densely populated areas; HCR is a high-capacity facility in a rural area; LCR is a low-capacity facility in a rural area.*

change in congestion weights for LCD2 is largest, greatly encouraging some individuals to choose this facility. The average change for HCD1 and HCD2 is only positive, discouraging some individuals from choosing those facilities. The magnitude of change required for both HCD1 and HCD2 is higher than LCD2.

Changes in congestion weights for HCD1 and HCD2 discourage individuals from 2 and 3 sections, respectively, from choosing those facilities. Changes in congestion weights concerning LCD1 encourage individuals from one section to choose it while discouraging individuals from another section. Lastly, changes in congestion weights regarding LCD2 encourage individuals from one section to choose it.

In practice, it may be valuable to identify high capacity facilities that are likely to be congested ahead of time. Then, individuals for whom these facilities are likely choices but have a lower capacity facility nearby can be encouraged to choose the lower capacity facility. This encouragement may come from both disincentives to choose the high capacity facility or incentives to choose the low capacity facility.

To summarize the findings of the study, the congestion component of the centralized plan-

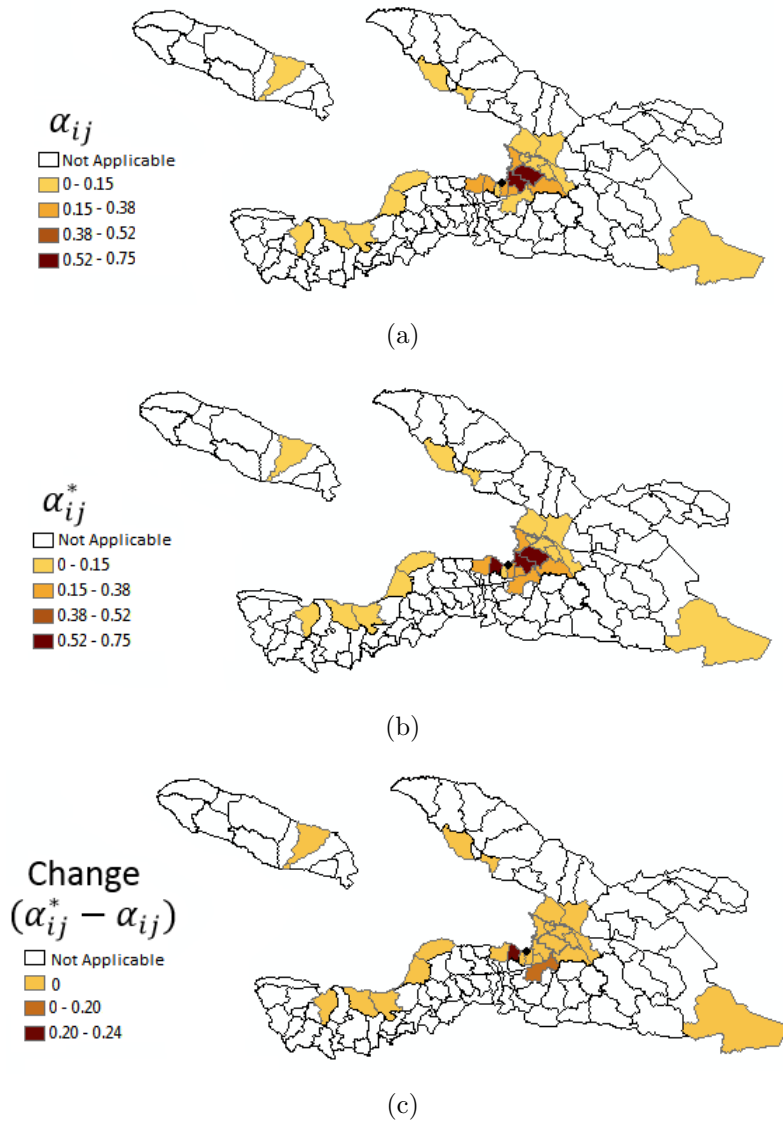

**Figure 4.13:** Initial (a) and optimized (b) congestion weights for HCD1; the average change in individuals' congestion weights for this facility (c).

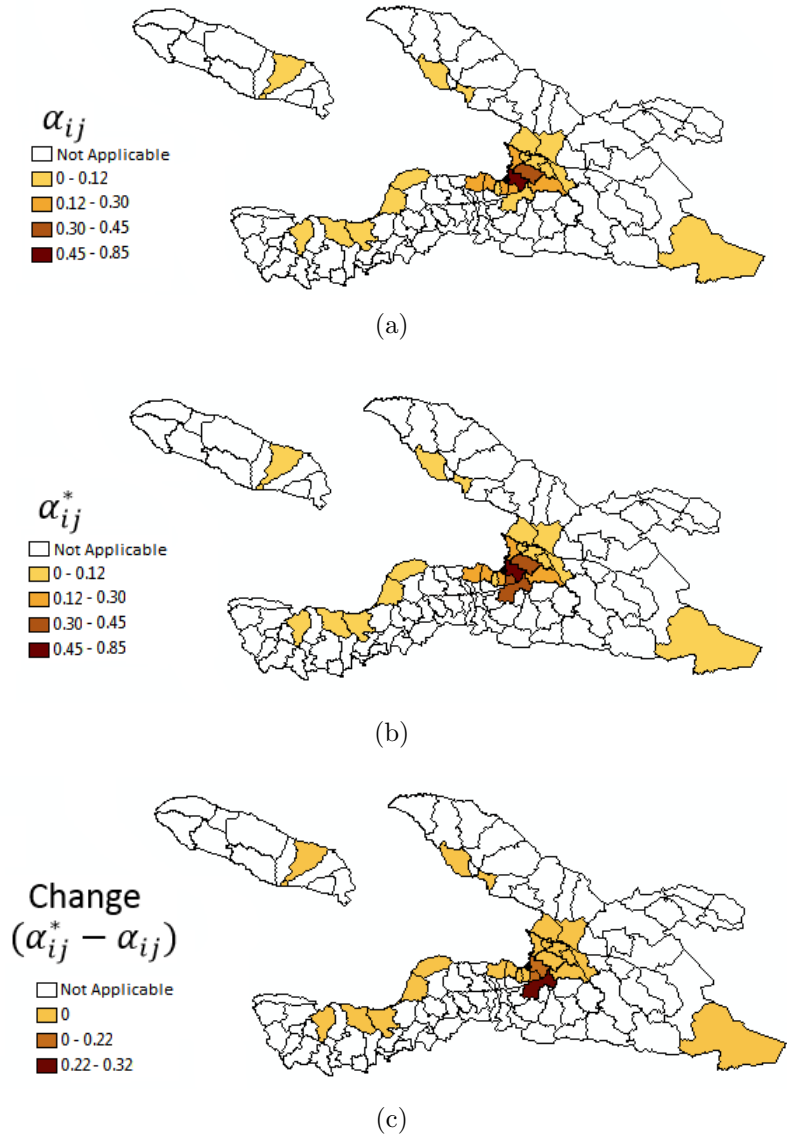

**Figure 4.14:** Initial (a) and optimized (b) congestion weights for HCD2; the average change in individuals' congestion weights for this facility (c).

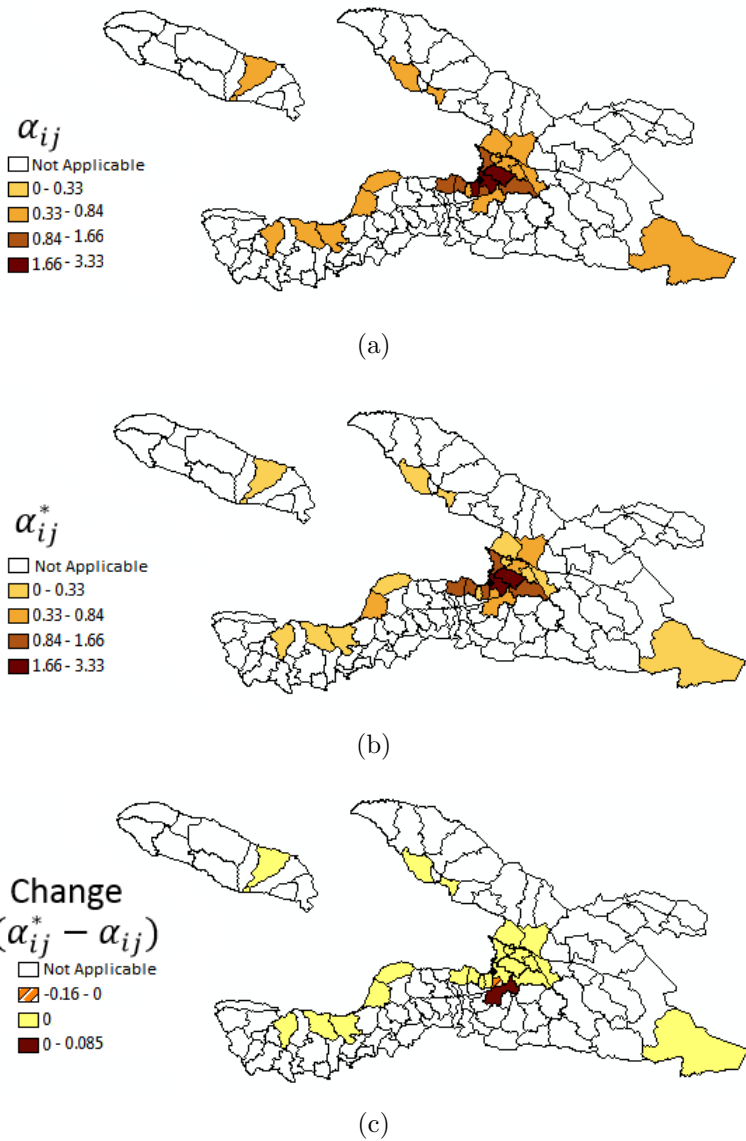

**Figure 4.15:** Initial (a) and optimized (b) congestion weights for LCD1; the average change in individuals' congestion weights for this facility (c).

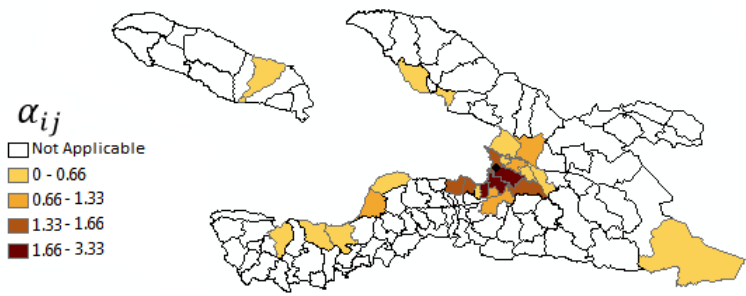

(a)

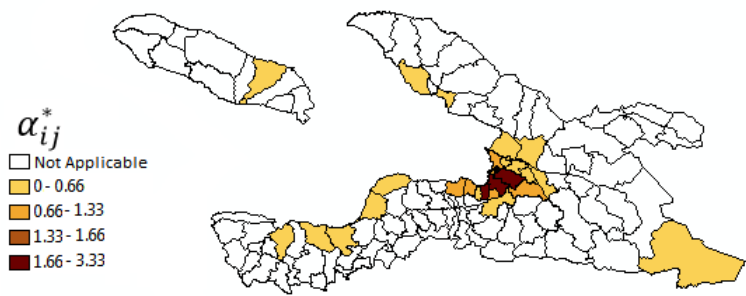

(b)

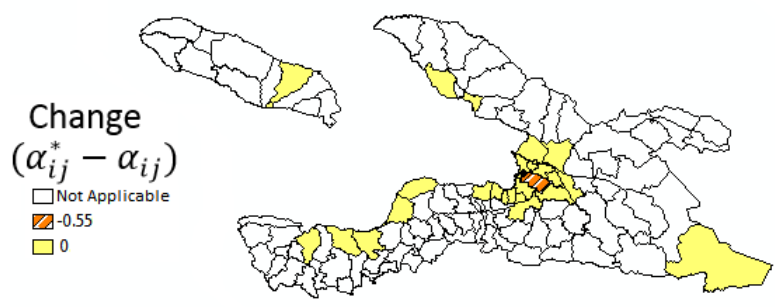

(c)

**Figure 4.16:** *Initial (a) and optimized (b) congestion weights for LCD2; the average change in individuals' congestion weights for this facility (c).*



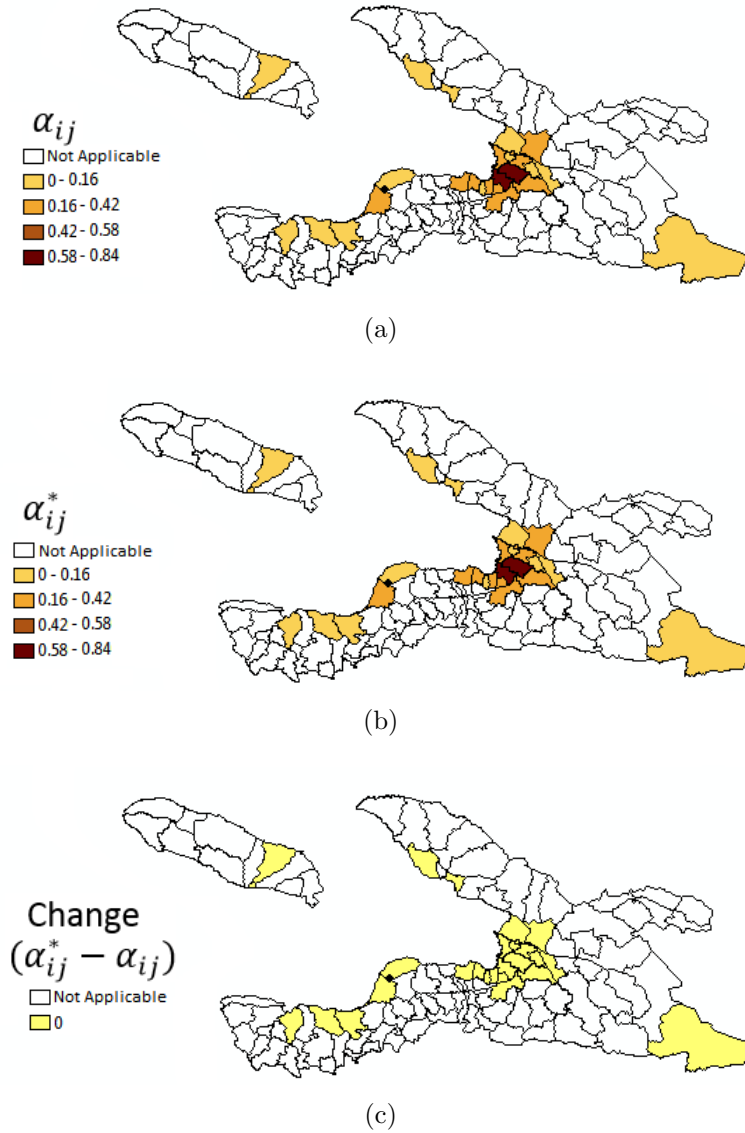

**Figure 4.17:** Initial (a) and optimized (b) congestion weights for a high capacity facility in a rural area; the average change in individuals' congestion weights for this facility (c).

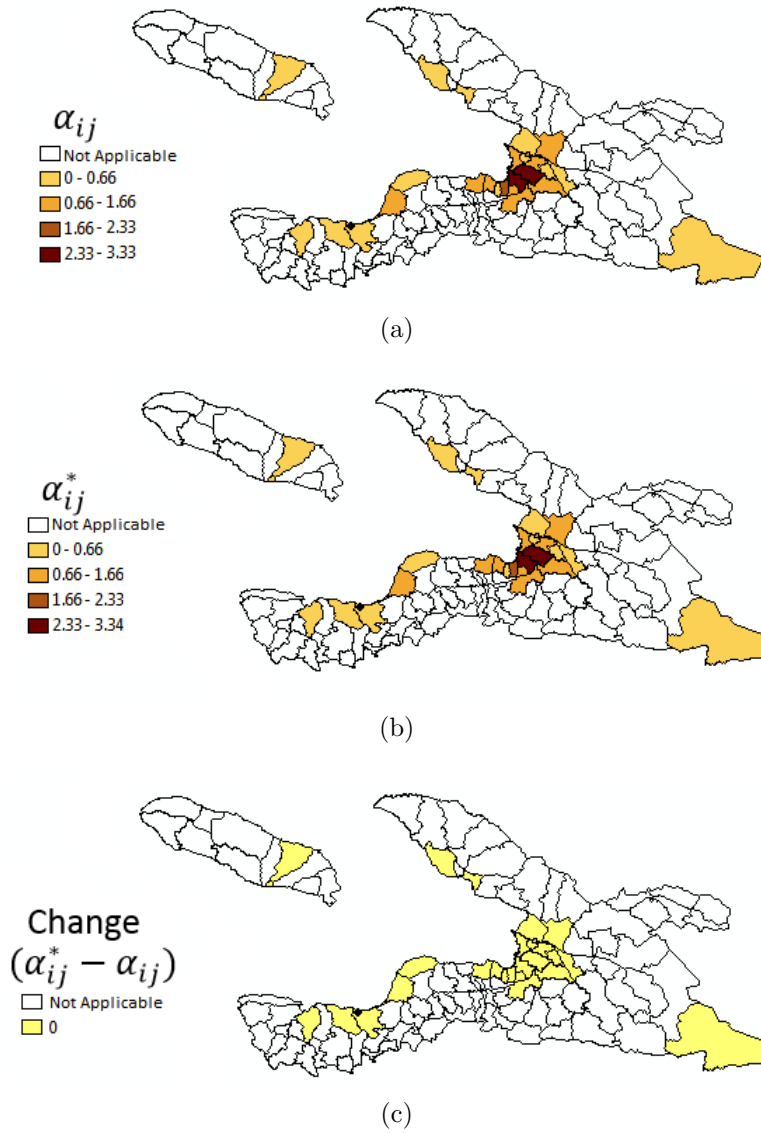

**Figure 4.18:** Initial (a) and optimized (b) congestion weights for low capacity facility in a rural area; the average change in individuals' congestion weights for this facility (c).

ner's objective function encourages the centralized optimum to spread individuals somewhat evenly across proximal facilities in densely populated areas. To make this solution an equilibrium, some individuals need to be encouraged to travel a little bit further to receive a lower utility than they would at the nearest facility. This encouragement comes in the form of an increased congestion weight for the nearby facility and possibly a decreased congestion weight for the assigned facility. Congestion weights concerning facilities with high capacities rarely need to be lowered, but those regarding facilities with low capacities do. This signifies that low-capacity facilities sometimes need to be made more attractive so that the optimal number of people choose them.

Taking into consideration the findings in the previous sections of this chapter, this study re-emphasizes the importance of coordination mechanisms to improve the performance of decentralized systems that may otherwise perform very poorly. The author has shown that these coordination mechanisms exist, but that because incentives come at a cost, implementing them may only be practical if the cost is minimized. The MCCMM accomplishes exactly this task.

## 4.7 Conclusion and Future Research

This chapter considers systems of beneficiaries seeking aid from a set of facilities in the wake of a disaster. In these instances, individuals make decisions based on personal preferences regarding the facility at which they will be served. Specifically, this research integrates two key factors: the distance that must be traveled and the congestion experienced. The author introduces two classes of congestion games denoted the PFSCWP and the PSCWP. The PFSCWP allows each player to place an independent weight on congestion for each facility, while the PSCWP requires that a player's congestion weight be applied identically to all facilities.

This research contributes many important theoretical results for the PFSCWP. The

author greatly extends the current understanding of the prices of anarchy and stability. Both measures can be arbitrarily high in general, but bounds on the price of anarchy are proven in terms of both the numbers of players and facilities, as well as the largest and smallest congestion weights. A substantial contribution is made in the area of coordination mechanisms as the author shows that there exist equilibrium obtaining congestion weights for any solution, demonstrating that it is possible for decentralized behavior to align with any centralized optimum.

Turning to the PSCWP, the author presents an algorithm for computing an equilibrium in polynomial time using a transformation to a minimum cost flow problem. Equilibrium solutions may also be arbitrarily expensive for the PSCWP, but these are shown to depend upon the greatest and least congestion weights. Coordination mechanisms are analyzed and it is shown that when  $\alpha_i = 2$  for all  $i \in N$ , the centralized optimum is always an equilibrium. Furthermore, there exists a range of  $\alpha_i$  values under which the centralized optimum is an equilibrium. In contrast to the PFSCWP, the existence of such coordination mechanisms does not extend to all solutions.

A method is designed and implemented in chapter 4.6 to identify congestion weights that transform a given centralized optimum into an equilibrium at minimum cost. Computational study results demonstrate that coordination mechanisms in the form of incentives are required if decentralized systems are to behave in a centrally optimal manner. For the case considered, these incentives are especially needed in areas with dense populations as facilities are more likely to experience heavy congestion. In addition, it may be beneficial to encourage individuals to choose facilities that have lower than average capacity to ease the burden of highly chosen facilities with high capacities.

The results of this research provide many important insights into how these systems perform. First, because an equilibrium can be computed efficiently and these solutions represent probable outcomes, logisticians may plan for decentralization and predict behavior. This ability to predict the decisions of beneficiaries may prove extremely valuable when

forecasting demand and allocating resources. It is shown that when the range of congestion weights is large, decentralized systems can perform very poorly. Thus, incentives may help beneficiaries view congestion at each facility similarly in order to achieve better outcomes. Lastly, the identification of coordination mechanisms may achieve system-optimal performance if the proper congestion weights are implemented.

There remain several avenues for future research. The decentralized model could be extended to integrate additional factors that impact beneficiary behavior. For instance, some individuals may make decisions based on the decisions of friends and family. These interdependent utilities could be integrated into the congestion game. Additional factors may include services offered at only a subset of facilities and name recognition or expertise of agencies that operate certain facilities. If player utility functions remain monotonic, these additional factors may be integrated without substantially increasing the complexity of computing an equilibrium solution.

More research is needed regarding the price of stability. This research shows that there exist instances where the price of stability is arbitrarily large. However, it would be beneficial to bound the price of stability in terms of input parameters. This way, logisticians may identify how well a decentralized system can perform. When combined with the price of anarchy results presented here, a metric that may be interesting to study is the ratio  $R = PA/PS$ , the upper and lower bounds of which determine the gap between the best and worst possible system behavior.

# Chapter 5

## Conclusion and Future Work

Humanitarian logistics systems operate in complex, dynamic, and uncertain environments and affect millions of lives. While mathematical optimization has long been an integral facet of commercial supply chain management, it is a relatively new technique within the humanitarian sector. This thesis demonstrates the usefulness of such an approach, focusing on the impact of decentralization within systems of response agencies and beneficiaries alike. The author demonstrates that decentralization may result in inefficient and inequitable outcomes.

In the first component of this work, existing applications of game theory from the literature are synthesized. The author discusses models of competition between relief organizations as they vie for donations and media exposure. The majority of research in the literature contends that competition between relief agencies negatively affects service to beneficiaries, but there are relatively few suggestions to mitigate the impact. Greater coordination between relief organizations may improve operational effectiveness but few models exist to overcome the numerous barriers. Moreover, there do not exist models that quantify the impact of decentralization in a truly realistic manner, neglecting sources of uncertainty, dynamism and personal preferences. This finding motivates the primary focus of the thesis.

The second component of this thesis quantifies the impact of decentralization on the part

of response agencies through a dynamic, robust facility location model. The model acts as a centralized benchmark that generates facility locations that optimize service accessibility. The benchmark maintains realism by incorporating multiple sources of uncertainty within a dynamic framework in which parameter values and location decisions may change over time. A computational study is performed using data obtained from the cholera 2010-2011 epidemic in Haiti. The results illustrate a stark difference in metrics of efficiency and equity between what was accomplished and what might have been achieved through coordinated facility location decisions.

The final component of this research models the decisions of beneficiaries through a congestion game that integrates individual preferences. The author defines the PFSCWP and the PSCWP, two new classes of games that model beneficiary behavior when seeking aid. A polynomial-time algorithm is constructed to compute equilibrium solutions, which represent likely decisions for the PSCWP. New theoretical bounds on the prices of anarchy and stability for the PSCWP and the PFSCWP are proven. These bounds represent the best and worst that decentralized systems can perform relative to a centralized optimum. Given the potentially catastrophic consequences of poor performance, the author identifies coordination mechanisms that encourage centrally optimal decisions within a decentralized environment. A characterization of solutions to the PSCWP that possess equilibrium obtaining congestion weights is presented. Furthermore, the author demonstrates that any solution to the PFSCWP may be transformed into an equilibrium.

Finally, an optimization model is introduced that computes equilibrium obtaining congestion weights while minimizing the cumulative change from an initial set of congestion weights. The models may be used by practitioners to identify what areas will most require incentives if beneficiaries are to make decisions that are best for the system. The method is implemented through a computational study that utilizes data from the cholera epidemic in Haiti.

There exist numerous opportunities for future research that applies game theory to

improve humanitarian operations. Given the existing competitive environment and the fact that most NGOs operate solely upon donations, models that identify the best sources of income and optimize potential gifts are highly valuable. Additional research may also help new NGOs find a niche within an already saturated market, improving the opportunity to receive donations for a specific or under-represented cause.

Substantial improvements should be made in the area of inter-agency coordination. Future work may improve inter-agency dynamics by creating models that identify compatible partnerships, establish appropriate roles and improve effectiveness. New technology may substantially increase opportunities for collaboration by decreasing the resources that it requires. Inter-agency information sharing may be improved through models that apply the concept of network centrality. These models might create mechanisms for efficiently saturating a network by identifying agencies that are most integral to the network.

Security for the personnel of response agencies is of paramount importance. As more and more NGOs become targets of violence, it becomes more difficult to recruit agencies and individuals to serve in these regions. Future research could apply game theory to find vulnerabilities, identify threats, and predict danger before it occurs.

The analysis performed in Chapter 3 utilizes the E2SFCA to optimize spatial access to services. Future research may incorporate new sources of uncertainty such as demand or the ability for NGOs to reach certain areas. The integration of geographical topology and transportation routing, where available, may enhance the model's prescriptive functionality. Furthermore, region-specific ability-to-travel weights may incorporate demographic information and transportation availability.

Future work should investigate coordination mechanisms that encourage agencies to make centrally optimal location decisions within the existing decentralized environment. In addition to identifying optimal locations, incentives may be required to encourage NGOs to participate. The literature shows that NGOs often congregate in areas where there is a high probability of media exposure. Perhaps this trend might be utilized to by positioning



media in areas that may otherwise be ignored. Models that identify optimal locations for media outlets might guide decentralized agencies toward decisions that benefit beneficiaries. These models should incorporate realities such as the cost of moving to certain locations, and the resources such as water and utilities that will be available. In addition, policies that ensure public acknowledgment for NGOs who agree to position facilities in a centrally optimal manner may improve the likelihood of participation.

Regarding models of decentralized beneficiaries, enhancements of the PFSCWP might add other factors that influence, the decision making process. For example, the choice of facility for an individual may be influenced by the facility chosen by family members, friends, and neighbors. If the utility an individual receives is determined by who chooses a facility rather than how many others choose it, the game belongs to the class of additively separable hedonic games, for which computing equilibrium solutions is *NP*-complete [145]. Future research may build heuristics that find near-equilibrium solutions for this game and identify bounds on the prices of stability and anarchy.

While this work demonstrates that the price of stability may be arbitrarily high for certain instances, future research may prove bounds on this value in terms of input parameters. Future work may also identify implementable practices to serve as coordination mechanisms for systems of beneficiaries. For example, offering transportation assistance to help distribute beneficiaries evenly and ease the congestion at facilities located in densely populated areas would be highly valuable. In addition, informing beneficiaries of congestion levels may encourage better decision making for those who are able to travel a greater distance in order to encounter less congestion.

# Bibliography

- [1] J. L. Heier Stamm, *Design and Analysis of Humanitarian and Public Health Logistics Systems*. PhD thesis, Georgia Institute of Technology, 2010.
- [2] B. Moore and J. L. Heier Stamm, “Impact of decentralized decision-making on access to public health facilities,” *Proceedings of the 2012 Industrial and Systems Engineering Research Conference, Orlando, FL.*, 2012.
- [3] C. Thevenaz and S. Resodihardjo, “All the best laid plans...conditions impeding proper emergency response,” *International Journal of Production Economics*, vol. 126, no. 1, pp. 7–21, 2010.
- [4] L. Muggy, “Game theory applications in humanitarian operations: A review,” *Journal of Humanitarian Logistics and Supply Chain Management*, vol. 4, no. 1, pp. 4–23, 2014.
- [5] B. Balcik, B. Beamon, and K. Smilowitz, “Last mile distribution in humanitarian relief,” *Journal of Intelligent Transportation Systems*, vol. 12, no. 2, pp. 51–63, 2008.
- [6] G. Kovács and K. Spens, “Humanitarian logistics in disaster relief operations,” *International Journal of Physical Distribution & Logistics Management*, vol. 37, no. 2, pp. 99–114, 2007.
- [7] A. Nagurney and M. Yu, “Supply chain network design for critical needs with outsourcing,” *Papers in Regional Science*, vol. 90, no. 1, pp. 123–142, 2011.
- [8] R. Overstreet, D. Hall, J. Hanna, and R. Rainer Jr., “Research in humanitarian logistics,” *Journal of Humanitarian Logistics and Supply Chain Management*, vol. 1, no. 2, pp. 114–131, 2011.

- [9] B. Balcik, B. Beamon, C. Krejci, K. M. Muramatsu, and M. Ramirez, “Coordination in humanitarian relief chains: Practices, challenges and opportunities,” *International Journal of Production Economics*, vol. 126, no. 1, pp. 22–34, 2010.
- [10] C. Maiers, M. Reynolds, and M. Haselkorn, “Challenges to effective information and communication systems in humanitarian relief organizations,” *International Professional Communication Conference Proceedings*, pp. 82–91, 2005.
- [11] D. Ketchen, Jr., and G. Hult, “Bridging organization theory and supply chain management: The case of best value supply chains,” *Journal of Operations Management*, vol. 25, no. 2, pp. 573–580, 2007.
- [12] G. Cachon and P. Zipkin, “Competitive and cooperative inventory policies in a two-stage supply chain,” *Management Science*, vol. 45, no. 7, pp. 936–953, 1999.
- [13] Z. Huang and S. Li, “Co-op advertising models in manufacturer-retailer supply chains: A game theory approach,” *European Journal of Operational Research*, vol. 135, no. 3, pp. 527–544, 2001.
- [14] M. Osborne, *An Introduction to Game Theory*. Oxford University Press, 2004.
- [15] R. Gibbons, *Game Theory for Applied Economists*. Princeton, NJ: Princeton University Press, 1992.
- [16] J. Nash, “Equilibrium points in  $n$ -person games,” *Proceedings of the National Academy of Sciences of the United States of America*, vol. 36, no. 1, pp. 48–49, 1950.
- [17] P. Frumkin and M. Kim, “Strategic positioning and the financing of nonprofit organizations: Is efficacy rewarded in the contributions marketplace?,” *Public Administration Review*, vol. 61, no. 3, pp. 266–275, 2001.
- [18] National Center for Charitable Statistics, “Quick facts about nonprofits,” 2013. Available at <http://nccs.urban.org/statistics/quickfacts.cfm>.

- [19] R. Waters and N. Tindall, “Exploring the impact of American news coverage on crisis fundraising: Using media theory to explicate a new model of fundraising communication,” *Journal of Nonprofit & Public Sector Marketing*, vol. 23, no. 1, pp. 20–40, 2011.
- [20] G. Olsen and N. Carstensen, “Humanitarian crises: What determines the level of emergency assistance? Media coverage, donor interests and the aid business.,” *Disasters*, vol. 27, no. 2, pp. 109–126, 2003.
- [21] C. L. Wardell, III, *Signaling and Search in Humanitarian Giving: Models of Donor and Organization Behavior in the Humanitarian Space*. PhD thesis, Georgia Institute of Technology, 2009.
- [22] J. Zhuang, G. Saxton, and H. Wu, “Publicity vs. impact in nonprofit disclosures and donor preferences: A sequential game with one nonprofit organization and  $n$  donors,” *Annals of Operations Research*, vol. 221, no. 1, pp. 469–491, 2014.
- [23] S. Feigenbaum, “Competition and performance in the nonprofit sector: The case of US medical research charities,” *The Journal of Industrial Economics*, vol. 35, no. 3, pp. 241–253, 1987.
- [24] M. Castaneda and J. T. J. Garen, “Competition, contractibility, and the market for donors to nonprofits,” *The Journal of Law, Economics & Organization*, vol. 24, no. 1, pp. 215–246, 2007.
- [25] J. Andreoni, “Impure altruism and donations to public goods: A theory of warm-glow giving,” *The Economic Journal*, vol. 100, no. 401, pp. 464–477, 1990.
- [26] A. Glazer and K. Konrad, “A signaling explanation for charity,” *The American Economic Review*, vol. 86, no. 4, pp. 1019–1028, 1996.

- [27] K. McCardle, K. Rajaram, and C. Tang, “A decision analysis tool for evaluating fundraising tiers,” *Decision Analysis*, vol. 6, no. 1, pp. 4–13, 2009.
- [28] N. Privett and F. Erhun, “Efficient funding: Auditing in the nonprofit sector,” *Manufacturing & Service Operations Management*, vol. 13, no. 4, pp. 471–488, 2011.
- [29] S. Ross, “The economic theory of agency: The principal’s problem,” *The American Economic Review*, vol. 63, no. 2, pp. 134–139, 1973.
- [30] S. Zenios, “Decentralized decision making in dynamic technological systems: The principal-agent paradigm,” *Handbook of Quantitative Supply Chain Analysis: Modeling in the E-Business Era*, pp. 117–140, 2004.
- [31] M. Besiou, “Decentralization and earmarked funding in humanitarian logistics for relief and development,” *23rd Annual Conference of the Production and Operations Management Society*, 2012.
- [32] W. Jie, “Exploration of dual organization in internal management of NGO,” *Information Management, Innovation Management and Industrial Engineering*, vol. 1, pp. 274–278, 2008.
- [33] A. K. Arshinder and S. Deshmukh, “Supply chain coordination: Perspectives, empirical studies and research directions,” *International Journal of Production Economics*, vol. 115, no. 2, pp. 316–335, 2008.
- [34] “Game theory in supply chain analysis,” *Handbook of Quantitative Supply Chain Analysis: Modeling in the E-Business Era*, pp. 13–65, 2004.
- [35] J. Coles and J. Zhuang, “Decisions in disaster recovery operations: A game theoretic perspective on organization cooperation,” *Journal of Homeland Security and Emergency Management*, vol. 8, no. 35, 2011.

- [36] M. Jahre and L. Jensen, “Coordination in humanitarian logistics through clusters,” *International Journal of Physical Distribution and Logistics Management*, vol. 40, no. 8/9, pp. 657–674, 2010.
- [37] S. Schulz and A. Blecken, “Horizontal cooperation in disaster relief logistics: Benefits and impediments,” *International Journal of Physical Distribution and Logistics Management*, vol. 40, no. 8/9, pp. 636–656, 2010.
- [38] F. Cruijssen, M. Cools, and W. Dullaert, “Horizontal cooperation in logistics: Opportunities and impediments,” *Transportation Research Part E: Logistics and Transportation Review*, vol. 43, no. 2, pp. 129–142, 2007.
- [39] A. Bagchi, J. Paul, and M. Maloni, “Improving bid efficiency for humanitarian food aid procurement,” *International Journal of Production Economics*, vol. 134, no. 1, pp. 238–245, 2011.
- [40] S. Hasija, “Fleet management coordination in decentralized humanitarian operations,” *23rd Annual Conference of the Production and Operations Management Society, Chicago, Illinois*, 2012.
- [41] J. Trestrail, J. Paul, and M. Maloni, “Improving bid pricing for humanitarian logistics,” *International Journal of Physical Distribution & Logistics Management*, vol. 39, pp. 428–441, 2009.
- [42] O. Ergun, L. Gui, J. L. Heier Stamm, P. Keskinocak, and J. Swann, “Improving humanitarian operations through technology-enabled collaboration,” *Production and Operations Management*, vol. 23, no. 6, pp. 1002–1014, 2014.
- [43] R. Proaño, S. Jacobson, and W. Zhang, “Making combination vaccines more accessible to low-income countries: The antigen bundle pricing problem,” *Omega*, vol. 40, no. 1, pp. 53–64, 2012.

- [44] A. Gatignon, L. V. Wassenhove, and A. Charles, “The Yogyakarta earthquake: Humanitarian relief through IFRC’s decentralized supply chain,” *International Journal of Production Economics*, vol. 126, no. 1, pp. 102–110, 2010.
- [45] M. Moshtari and J. Gonçalves, “Understanding the drivers and barriers of coordination among humanitarian organizations,” *23rd Annual Conference of the Production and Operations Management Society, Chicago, Illinois*.
- [46] J. Zhuang, J. Yates, and J. Coles, “Measuring partnership efficacy in Haitian disaster recovery,” *Proceedings of 2011 NSF Engineering Research and Innovation Conference, Atlanta, Georgia*, 2011.
- [47] J. Coles, J. Zhuang, and J. Yates, “Case study in disaster relief: A descriptive analysis of agency partnerships in the aftermath of the January 12th, 2010 Haitian earthquake,” *Socio-Economic Planning Sciences*, vol. 46, no. 1, pp. 67–77, 2012.
- [48] R. McLachlin and P. Larson, “Building humanitarian supply chain relationships: Lessons from leading practitioners,” *Journal of Humanitarian Logistics and Supply Chain Management*, vol. 1, no. 1, pp. 32–49, 2011.
- [49] P. Tatham and G. Kovács, “The application of “swift trust” to humanitarian logistics,” *International Journal of Production Economics*, vol. 126, no. 1, pp. 35–45, 2010.
- [50] A. Natsios, “NGOs and the UN system in complex humanitarian emergencies: Conflict or cooperation?,” *Third World Quarterly*, vol. 16, no. 3, pp. 405–419, 1995.
- [51] S. Brams, “Theory of moves,” *American Scientist*, vol. 81, pp. 562–570, 1994.
- [52] S. Wilson, “Long term behavior in the theory of moves,” *Theory and Decision*, vol. 45, no. 3, pp. 201–240, 1998.
- [53] L. Zeager, “Negotiations for refugee repatriation or local settlement: A game-theoretic analysis,” *International Studies Quarterly*, vol. 42, no. 2, pp. 367–384, 1998.

- [54] L. Zeager, “The role of strategic threats in refugee resettlement,” *Rationality and Society*, vol. 14, no. 2, pp. 159–191, 2002.
- [55] J. Williams and L. Zeager, “Macedonian border closings in the Kosovo refugee crisis: A game-theoretic perspective,” *Conflict Management and Peace Science*, vol. 21, no. 4, pp. 233–254, 2004.
- [56] L. Olson, “Fighting for humanitarian space: NGOs in Afghanistan,” *Journal of Military and Strategic Studies*, vol. 9, no. 1, 2006.
- [57] G. Heaslip, A. Sharif, and A. Althonayan, “Employing a systems-based perspective to the identification of inter-relationships within humanitarian logistics,” *International Journal of Production Economics*, vol. 139, no. 2, pp. 377–392, 2012.
- [58] G. Brown, M. Carlyle, and J. Salmerón, “Analyzing the vulnerability of critical infrastructure to attack, and planning defenses,” *Tutorials on Operations Research: Emerging Theory, Methods, and Applications*, pp. 102–123, 2005.
- [59] J. Zhuang and V. Bier, “Balancing terrorism with natural disasters -Defensive strategy with endogenous attacker effort,” *Operations Research*, vol. 55, no. 5, pp. 976–991, 2007.
- [60] G. Kovács and P. Tatham, “Responding to disruptions in the supply network-From dormant to action,” *Journal of Business Logistics*, vol. 30, no. 2, pp. 215–229, 2011.
- [61] M. Daskin, *Network and Discrete Location: Models, Algorithms and Applications*. New York, NY: John Wiley and Sons Inc., 1995.
- [62] A. De Palma, V. Ginsburgh, and J. Thisse, “Competitive location with random utilities,” *Transportation Science*, vol. 23, no. 4, 1989.
- [63] J. L. Heier Stamm, O. Ergun, and J. Swann, “Analyzing and managing service networks with self-routing users,” *Under review*.



- [64] E. Shim, G. Chapman, J. Townsend, and A. Galvani, “The influence of altruism on influenza vaccination decisions,” *Journal of the Royal Society Interface*, vol. 9, no. 74, 2012.
- [65] S. Moore, E. Eng, and M. Daniel, “International NGOs and the role of network centrality in humanitarian aid operations: A case study of coordination during the 2000 Mozambique floods,” *Disasters*, vol. 27, no. 4, pp. 305–318, 2003.
- [66] N. Kapucu, “Interorganizational coordination in dynamic context: Networks in emergency response management,” *Connections*, vol. 26, no. 2, pp. 33–48, 2005.
- [67] J. Stewart, R. Kolluru, and M. Smith, “Leveraging public-private partnerships to improve community resilience in times of disaster,” *International Journal of Physical Distribution and Logistics Management*, vol. 39, no. 39, pp. 343–364, 2009.
- [68] J. Wu, S. Zhao, and D. Ben-Arieh, “Modeling infection spread and behavioral change using spatial games,” *Working Paper*, 2013.
- [69] S. Alumur, S. Nickel, and F. Saldanha-da-Gama, “Hub location under uncertainty,” *Transportation Research Part B*, vol. 46, no. 4, pp. 529–543, 2012.
- [70] A. Ghaderi and M. Jabalameli, “Modeling the budget-constrained dynamic uncapacitated facility location-network design problem and solving it via two efficient heuristics: A case study of health care,” *Mathematical and Computer Modelling*, vol. 57, no. 3-4, pp. 382–400, 2013.
- [71] S. Kara and S. Onut, “A two-stage stochastic and robust programming approach to strategic planning of a reverse supply network: The case of paper recycling,” *Expert Systems with Applications*, vol. 37, no. 9, pp. 6129–6137, 2010.
- [72] B. Balcik and B. Beamon, “Facility location in humanitarian relief,” *International Journal of Logistics: Research and Applications*, vol. 11, no. 2, pp. 101–121, 2008.

- [73] A. Döyen, N. Aras, and G. Barbarosoğlu, “A two-echelon stochastic facility location model for humanitarian relief logistics,” *Optimization Letters*, vol. 6, no. 6, pp. 1123–1145, 2012.
- [74] N. Görmez, M. Köksalan, and F. Salman, “Locating disaster response facilities in Istanbul,” *Journal of the Operational Research Society*, vol. 62, pp. 1239–1252, 2011.
- [75] H. Jia, F. Ordóñez, and M. Dessouky, “A modeling framework for facility location of medical services for large-scale emergencies,” *IIE Transactions*, vol. 39, no. 1, pp. 41–55, 2007.
- [76] J. Salmerón and A. Apte, “Stochastic optimization for natural disaster asset prepositioning,” *Production and Operations Management*, vol. 19, no. 5, pp. 561–574, 2010.
- [77] S. H. Owen and M. S. Daskin, “Strategic facility location: A review,” *European Journal of Operational Research*, vol. 111, no. 3, pp. 423–447, 1998.
- [78] A. Khan, “An integrated approach to measuring potential spatial access to health care services,” *Socio-Economic Planning Sciences*, vol. 26, no. 4, pp. 275–287, 1992.
- [79] M. Guagliardo, “Spatial accessibility of primary care: Concepts, methods and challenges,” *International Journal of Health Geographics*, vol. 3, no. 3, pp. 3–13, 2004.
- [80] W. Luo and F. Wang, “Measures of spatial accessibility to health care in a GIS environment: Synthesis and a case study in the Chicago region,” *Environment and Planning B: Planning and Design*, vol. 30, no. 6, pp. 865–884, 2003.
- [81] M. Mandell, “Modelling effectiveness-equity trade-offs in public service delivery systems,” *Management Science*, vol. 37, no. 4, pp. 467–482, 1991.
- [82] W. Luo and Y. Qi, “An enhanced two-step floating catchment area (E2SFCA) method for measuring spatial access to primary care physicians,” *Health and Place*, vol. 15, no. 4, pp. 1100–1107, 2009.

- [83] L. McLay and M. Mayorga, “A dispatching model for server-to-customer systems that balances efficiency and equity,” *Manufacturing and Service Operations Management*, vol. 15, no. 2, pp. 205–220, 2013.
- [84] E. Savas, “On equity in providing public services,” *Management Sciences*, vol. 24, no. 8, pp. 800–808, 1978.
- [85] N. Serban, “A space-time varying coefficient model: The equity of service distribution,” *Annals of Applied Statistics*, vol. 5, no. 3, 2011.
- [86] W. Luo and T. Whippo, “Variable catchment sizes for the two-step floating catchment area (2SFCA) method,” *Health and Place*, vol. 18, no. 4, pp. 789–795, 2012.
- [87] R. Aboolian, O. Berman, and V. Verter, “Maximal accessibility network design in the public sector,” *Transportation Science: Articles in Advance*, pp. 1–12, 2015.
- [88] A. Li, L. Nozick, N. Xu, and R. Davidson, “Shelter location and transportation planning under hurricane conditions,” *Transportation Research Part E*, vol. 48, no. 4, pp. 715–729, 2012.
- [89] J. L. Heier Stamm, N. Serban, J. Swann, and P. Wortley, “Quantifying and explaining accessibility with application to the 2009 H1N1 vaccination campaign.” Under review, 2015.
- [90] Z. Peng, “The jobs-housing balance and urban commuting,” *Urban Studies*, vol. 34, pp. 1215–1235, 1997.
- [91] F. Wang, “Modeling commuting patterns in Chicago in a GIS environment: A job accessibility perspective,” *Professional Geographer*, vol. 52, no. 1, pp. 120–133, 2000.
- [92] F. Cervigni, Y. Suzuki, T. Ishil, and A. Hata, “Spatial accessibility to pediatric services,” *Journal of Community Health*, vol. 33, no. 6, pp. 444–448, 2008.

- [93] P. Delamatar, “Spatial accessibility in suboptimally configured healthcare systems: A modified two-step floating catchment area (M2SFCA) metric,” *Health and Place*, vol. 24, pp. 30–43, 2013.
- [94] M. McGrail and J. Humphreys, “Measuring spatial accessibility to primary care in rural areas: Improving the effectiveness of the two-step floating catchment area method,” *Applied Geography*, vol. 29, no. 4, pp. 533–541, 2009.
- [95] A. Ngui and P. Apparicio, “Optimizing the two-step floating catchment area method for measuring spatial accessibility to medical clinics in Montreal,” *BMC Health Services Research*, vol. 11, no. 166, 2011.
- [96] N. Wan, F. Zhan, B. Zou, and E. Chow, “A relative spatial access assessment approach for analyzing potential spatial access to colorectal cancer services in Texas,” *Applied Geography*, vol. 32, no. 2, pp. 291–299, 2012.
- [97] M. Langford, R. Fry, and G. Higgs, “Measuring transit system accessibility using a modified two-step floating catchment technique,” *International Journal of Geographical Information Science*, vol. 26, no. 2, pp. 193–214, 2012.
- [98] E. Erkut, “Inequality measures for location problems,” *Location Science*, vol. 1, no. 3, pp. 199–217, 1993.
- [99] W. Ogryczak, “Inequality measures and equitable locations,” *Annals of Operations Research*, vol. 167, no. 1, pp. 61–86, 2009.
- [100] P. Braveman and S. Gruskin, “Defining equity in health,” *Journal of Epidemiology and Community Health*, vol. 57, no. 4, pp. 254–258, 2003.
- [101] A. Culyer and A. Wagstaff, “Equity and equality in health and health care,” *Journal of Health Economics*, vol. 2, pp. 431–457, 1993.

- [102] P. Leclerc, L. McLay, and M. Mayorga, “Modeling equity for allocating public resources,” *Community-Based Operations Research (M. P. Johnson, ed.), International Series in Operations Research and Management Science*, vol. 57, pp. 97–118, 2011.
- [103] M. Marsh and D. Schilling, “Equity measurement in a facility location analysis: A review and framework,” *European Journal of Operational Research*, vol. 74, no. 1, pp. 1–17, 1994.
- [104] Y. Lai, Y. Ouyang, and C. Barkan, “A rolling horizon model to optimize aerodynamic efficiency of intermodal freight trains with uncertainty,” *Transportation Science*, vol. 42, no. 4, pp. 466–477, 2008.
- [105] J. Soto, *Dynamic and robust capacitated facility location in time varying demand environments*. PhD thesis, Texas A and M University, 2009.
- [106] J. Soto and H. Üster, “Dynamic-demand capacitated facility location problems with and without relocation,” *International Journal of Production Research*, vol. 49, no. 13, pp. 3979–4005, 2011.
- [107] J. Mulvey, R. Vanderbei, and S. Zenios, “Robust optimization of large-scale systems,” *Operations Research*, vol. 43, no. 2, pp. 264–281, 1995.
- [108] L. Snyder, “Facility location under uncertainty: A review,” *IIE Transactions*, vol. 38, no. 7, pp. 547–564, 2006.
- [109] P. Murali, F. Ordóñez, and M. Dessouky, “Facility location under demand uncertainty: Response to a large-scale bio-terror attack,” *Socio-Economic Planning Services*, vol. 46, no. 1, pp. 78–87, 2012.
- [110] V. De Rosa, M. Gebhard, E. Hartmann, and J. Wollenweber, “Robust sustainable bi-directional logistics network design under uncertainty,” *International Journal of Production Economics*, vol. 145, no. 1, pp. 184–198, 2013.

- [111] V. De Rosa, E. Hartmann, M. Gebhard, and J. Wollenweber, “Robust capacitated facility location model for acquisitions under uncertainty,” *Computers and Industrial Engineering*, vol. 72, pp. 206–216, 2014.
- [112] O. Baron, J. Milner, and H. Naseraldin, “Facility location: A robust optimization approach,” *Production and Operations Management*, vol. 20, no. 5, pp. 772–785, 2011.
- [113] N. Gülpinar, D. Pachamanova, and E. Çanakoglu, “Robust strategies for facility location under uncertainty,” *European Journal of Operational Research*, vol. 225, no. 1, pp. 21–35, 2013.
- [114] T. Sim, T. Lowe, and B. Thomas, “The stochastic  $p$ -hub center problem with service-level constraints,” *Computers and Operations Research*, vol. 36, no. 12, pp. 3166–3177, 2009.
- [115] T. Yang, “Stochastic air freight hub location and flight routes planning,” *Applied Mathematical Modelling*, vol. 33, no. 12, pp. 4424–4430, 2009.
- [116] United Nations Development Programme, “Haiti: One year later,” 2011. Available at [http://www.undp.org/content/dam/undp/library/crisis%20prevention/disaster/latin\\_america/Haiti-1YearLater-E-final-sm.pdf](http://www.undp.org/content/dam/undp/library/crisis%20prevention/disaster/latin_america/Haiti-1YearLater-E-final-sm.pdf).
- [117] U.S. Centers for Disease Control and Prevention, “Cholera: General information,” 2014. Available at <http://www.cdc.gov/cholera/general/>.
- [118] World Health Organization, “Global health cluster,” 2011. Available at [http://www.who.int/hac/global\\_health\\_cluster/en/](http://www.who.int/hac/global_health_cluster/en/).
- [119] Pan American Health Organization, “As cholera death toll climbs in post-earthquake Haiti, new studies show disease emerging as a driver of progress in public health,” October 2013. Available at <http://www.paho.org/hq/index.php?id=9071%3Aas-cholera-death-toll-climbs-in-post-earthquake-haiti-new-studies-show>

disease-emerging-as-a-driver-of-progress-in-public-health&option=com\_content.

- [120] U.S. Centers for Disease Control and Prevention, “2010 Haiti cholera outbreak: Data,” 2011. Available at <http://emergency.cdc.gov/situationawareness/haiticholera/data.asp>.
- [121] Pan American Health Organization, “Cholera in Haiti, 2010,” 2011. Available at [http://new.paho.org/hq/images/Atlas\\_IHR/CholeraHispaniola/atlas.html](http://new.paho.org/hq/images/Atlas_IHR/CholeraHispaniola/atlas.html).
- [122] Ministere de la Sante Publique et de la Population (Ministry of Public Health and Population), “Rapports journaliers du MSPP sur l’evolution du cholera en Haiti (Daily reports of MSPP on the evolution of cholera in Haiti),” 2011. Available at <http://www.mspp.gouv.ht/site/>.
- [123] Haitian Institute of Statistics and Information, “Total population, population 18 years and over, households, and density estimates in 2009,” 2009. Available at <http://www.ihsi.ht/>.
- [124] Central Intelligence Agency, “Central America and Caribbean: Haiti,” 2013. Available at <https://www.cia.gov/library/publications/the-world-factbook/geos/ha.html>.
- [125] H. Ackermann and A. Skopalik, “On the complexity of pure Nash equilibria in player-specific network congestion games,” *Internet and Network Economics, Lecture Notes in Computer Science*, vol. 4858, pp. 419–430, 2007.
- [126] R. Cominetti, J. Correa, and N. Stier-Moses, “Network games with atomic players,” *Automated Languages and Programming*, pp. 525–536, 2006.
- [127] M. Mavronicolas, I. Milchtaich, B. Monien, and K. Tiemann, “Congestion games with

- player-specific constants,” *Mathematical Foundations of Computer Science, Lecture Notes in Computer Science*, vol. 4708, pp. 633–644, 2007.
- [128] M. Gairing and F. Schoppmann, “Total latency in singleton congestion games,” *Lecture Notes in Computer Science*, pp. 381–387, 2007.
- [129] H. Ackermann, H. Röglin, and B. Vöcking, “Pure Nash equilibria in player-specific and weighted congestion games,” *Internet and Network Economics, Lecture Notes in Computer Science*, vol. 4286, pp. 50–61, 2006.
- [130] A. Kothari, S. Suri, C. Tóth, and Y. Zhou, “Congestion games, load balancing, and price of anarchy,” *Combinatorial and Algorithmic Aspects of Networking, Lecture Notes in Computer Science*, vol. 3405, pp. 13–27, 2005.
- [131] M. Gairing, B. Monien, and K. Tiemann, “Routing (un-) splittable flow in games with player-specific affine latency functions,” *Automata, Languages and Programming, Lecture Notes in Computer Science*, vol. 4051, no. 1, 2006.
- [132] T. Roughgarden and Éva Tardos, “Bounding the inefficiency of equilibria in nonatomic congestion games,” *Games and Economic Behavior*, vol. 47, no. 2, 2003.
- [133] R. Rosenthal, “A class of game possessing pure strategy Nash equilibria,” *International Journal of Game Theory*, vol. 2, no. 1, pp. 65–67, 1973.
- [134] B. Vöcking and R. Aachen, “Congestion games: Optimization in competition,” *Proceedings of the 2nd Algorithms and Complexity in Durham Workshop*, 2006.
- [135] I. Milchtaich, “Congestion games with player-specific payoff functions,” *Games and Economic Behavior*, vol. 13, no. 27, pp. 111–124, 1996.
- [136] D. Monderer and L. Shapley, “Potential games,” *Games and Economic Behavior*, vol. 14, no. 44, pp. 124–143, 1996.



- [137] C. Tekin, M. Liu, R. Southwell, J. Huang, and S. Ahmad, “Atomic congestion games on graphs and its applications in networking,” *IEEE/ACM Transactions on Networking*, vol. 20, no. 5, pp. 1541–1552, 2012.
- [138] G. Christodoulou and E. Koutsoupias, “On the price of anarchy and stability of correlated equilibria of linear congestion games,” *Lecture Notes in Computer Science*, vol. 3669, pp. 59–70, 2005.
- [139] G. Christodoulou, E. Koutsoupias, and A. Nanavati, “Coordination mechanisms,” *Automata, Language and Programming*, pp. 345–357, 2003.
- [140] T. Harks and M. Klimm, “On the existence of pure Nash equilibria in weighted congestion games,” *Automata, Languages and Programming, Lecture Notes in Computer Science*, vol. 6198, pp. 79–89, 2010.
- [141] E. Aarts and J. Lenstra, *Local Search*. Princeton, New Jersey: Princeton University Press, 1997.
- [142] G. Christodoulou and E. Koutsoupias, “The price of anarchy of finite congestion games,” *Proceedings of the Thirty-seventh Annual ACM Symposium on Theory of Computing*, vol. 67-73, 2005.
- [143] A. Fabrikant, C. Papadimitriou, and K. Talwar, “The Complexity of Pure Nash Equilibria,” *Proceedings of the Thirty-sixth Annual ACM Symposium on Theory of Computing*, pp. 604–612, 2004.
- [144] B. Awerbuch, Y. Azar, and A. Epstein, “The price of routing unsplittable flow,” *SIAM Journal on Computing*, vol. 42, pp. 633–644, 2013.
- [145] M. Olsen, “Nash stability is additively separable hedonic games and community structures,” *Theory of Computer Systems*, vol. 45, no. 4, pp. 917–925, 2009.

# Appendix A

## Supplementary Material for Chapter 3: Examples

### A.1 An example illustrating the functionality of $f_j^t$

The rolling horizon model presented in §3.3 uses the parameter  $f_j^t$  when a facility  $j$  is opened in some period  $t$  and must remain open beyond the end of the planning horizon in order to achieve  $m$  consecutive periods of operation. The parameter supplements the number of periods that a facility will remain operational beyond the planning horizon so as to satisfy constraint sets (13) and (30). The following example demonstrates how  $f_j^t$  functions in the model.

**Example 1.** (From [2]) Let  $t_0 = 4$ ,  $\tau = 3$ , and  $m = 4$ . Suppose  $j$  has never been open before  $t_0$ . Thus,  $\sum_{l=0}^{t_0-1} H_{jks}^l = 0$  and  $h_{jks}^{t_0} = 0$ . The parameter  $f_j^t$  is calculated by

$$f_j^t = \max\{0, t - (\tau + t_0) + (m - 1)\} \quad \forall t \in t_0 \dots t_0 + \tau.$$

Constraint (13) reduces to

$$0 + (x_j^4 + z_j^4(0)) + (x_j^5 + z_j^5(1)) + (x_j^6 + z_j^6(2)) + (x_j^7 + z_j^7(3)) \geq 4\left(\sum_{t=4}^7 z_j^t + 0\right).$$

Facility  $j$  may be opened in any period in the planning horizon, but only once due to constraint (12). Suppose  $j$  is planned to be open in period 6. Constraint (13) is calculated by  $0 + (0 + 0) + (0 + 0) + (1 + 1(2)) + (1 + 0) \geq 4(1 + 0)$  which is satisfied.

## A.2 Clarification of the sufficient access threshold $\phi$

The parameter  $\phi$  determines the threshold for what is considered to be sufficient access. If the sum of the weighted capacity-to-demand ratios within the catchments of a population  $i$  is less than  $\phi$ , that population is said to have insufficient access. The following example lends greater clarity to the meaning of a particular  $\phi$  value.

**Example 2.** Consider two population locations denoted 1 and 2 with demands  $D_1 = 4000$  and  $D_2 = 3500$  and restrict these populations to the low ability to travel given by  $(1 \ 0.239 \ 0.057)$ . Consider three facility locations denoted 1, 2 and 3, with capacities  $C_1 = 80$ ,  $C_2 = 30$ , and  $C_3 = 80$  respectively, located within the catchments of the two populations as in Figure A.1.

Weighted capacity-to-demand ratios for each facility are calculated by

$$R_1 = \frac{80}{0.239*4000+0.057*3500} = 0.069,$$

$$R_2 = \frac{30}{0.239*3500+0.057*4000} = 0.028, \text{ and}$$

$$R_3 = \frac{80}{0.057*4000+0.057*3500} = 0.187.$$

The resulting access scores for the two populations are

$$A_1 = 0.239(0.069) + 0.057(0.028 + 0.187) = 0.028 \text{ and}$$

$$A_2 = 0.239(0.028) + 0.057(0.069 + 0.187) = .021.$$

These values satisfy the access sufficiency constraint where  $\phi = 0.02$ .

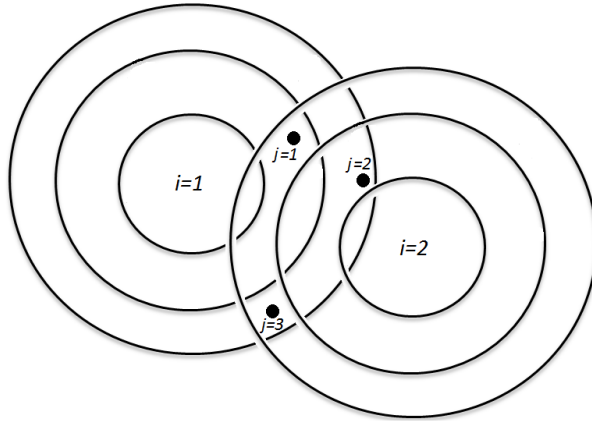

**Figure A.1:** *Population and facility locations in Example 2, illustrating sufficient access.*

In this example, 7,500 patients visit one of three facilities containing a total of 190 beds. On average, this allows 1.3 patients to use each bed per day, corresponding to 17.24 hours per patient per bed. To demonstrate that 17.24 hours per patient per bed satisfies conditions for sufficient treatment, consider that between 80 and 90 percent of cholera victims require rehydration alone, which typically requires three to four hours to complete [120].

# Appendix B

## Supplementary Material for Chapter 4

Despite the fact that this thesis focuses on problem settings in which individuals seek to minimize congestion, other settings may be characterized by beneficiaries who desire a facility chosen by many other people. For example, during some humanitarian crises, beneficiaries may find safety in numbers, desiring a facility or refugee camp in which many others have found respite. In this case, the congestion game may integrate player utility functions where greater congestion is desired. Mathematically, this is accomplished by setting  $\alpha_{ij} \leq 0$  for all players  $i$  and facilities  $j$ . Computing equilibria in this game can still be done in polynomial time as utility functions remain monotonic in congestion. The following theorem demonstrates that for a given solution  $X$ , there exist non-positive  $\alpha_{ij}$  values for which  $X$  is an equilibrium.

**Theorem 15** *For any instance  $G$  of the PFSCWP and solution  $X$ , there exist non-positive congestion weights  $\alpha_{ij}$  for which  $X$  is an equilibrium.*

*Proof.* Consider an instance  $G$  of the PFSCWP and a solution  $X$ . For each player  $i$ , let  $d_{i,min}$  and  $d_{i,max}$  be the distance from  $i$  to the nearest and farthest facilities and let  $x_{min}$  and  $x_{max}$  be the populations of the facilities with the least and greatest number of players,

respectively. For each player  $i$ , let  $\alpha_{ij} = \frac{-d_{i,max}}{x_{min}}$  where  $j$  is the facility chosen by player  $i$ . For each of the other facilities  $k \neq j$ , let  $\alpha_{ik} = \frac{-d_{i,min}}{x_{max}+1}$ .

The utility of each player at his chosen facility is  $\frac{-d_{i,max}}{x_{min}}x_j + d_{ij} = \frac{x_j}{x_{min}}(-d_{i,max}) + d_{ij} \leq 0$  since  $\frac{x_j}{x_{min}} \geq 1$  and  $d_{i,max} \geq d_{ij}$ .

The utility of person  $i$  upon switching to facility  $k$  would be  $\frac{-d_{i,min}}{x_{max}+1}(x_k + 1) + d_{ik} = \frac{x_k+1}{x_{max}+1}(-d_{i,min}) + d_{ik} \geq 0$  since  $\frac{x_k+1}{x_{max}+1} \leq 1$  and  $d_{i,min} \leq d_{ik}$ .

Therefore,  $\alpha_{ij}x_j + d_{ij} \leq \alpha_{ik}(x_{ik} + 1) + d_{ik}$  implying  $X$  is a Nash equilibrium.  $\square$