

THE OCCURRENCE OF THE DOUBLE-MUSCLED
CHARACTER IN BEEF CATTLE

by

WALTER HENRY SMITH

B. S., Kansas State College
of Agriculture and Applied Science, 1943

A THESIS

submitted in partial fulfillment of the

requirements for the degree

MASTER OF SCIENCE

Department of Animal Husbandry

KANSAS STATE COLLEGE
OF AGRICULTURE AND APPLIED SCIENCE

1949

TABLE OF CONTENTS

INTRODUCTION.....	1
REVIEW OF THE LITERATURE.....	3
MATERIAL AND METHODS.....	5
RESULTS.....	6
Description of the Double-Muscled Character.....	6
Mode of Inheritance of the Double-Muscled Character.....	34
Characteristics of the Double-Muscled Carcass.....	40
SUMMARY AND CONCLUSIONS.....	61
ACKNOWLEDGMENT.....	63
LITERATURE CITED.....	64

INTRODUCTION

Natural beef qualities are considered to be developmental characters which change in their proportions as cattle become older. Normal thick muscle development appears to be determined by multiple factors and is dependent upon a high plane of nutrition for maximum development.

Although individual animals vary considerably in respect to the thickness of their carcass parts, Weber and Ibsen (10) reported a type of beef cattle that is abnormally thick muscled in the region of the rump and thighs. The term "double-muscled" was used to identify this character which is a distinct deviation from normal thick muscling. According to Weber and Ibsen (10) this type has been recognized for many years by packers who refer to these animals as "Yorkshires" or describe them as being "bottle-thighed." The latter term, which is commonly used by packers in this section of the country, was somewhat modified by the authors so that it would be suitable for publication.

Double-muscled cattle have been known in Europe for many years. Kaiser (1) reported the character in the cattle of Europe in 1898. According to Wriedt (11) and Kronacher (2 and 3) it is called "doppellender" in Germany. Wriedt (11) stated that the character occurred frequently in the black and white lowland cattle and mentioned that it had been reported in France and Italy. The character has also been observed in the cattle of Denmark (Möller, 7) and Norway (Pyndt, 8).

Weber and Ibsen (10) presented evidence that the double-muscled character has occurred in the purebred Angus, Hereford, and Galloway beef breeds in the United States. Although it has not been observed in the Shorthorns in this country, it has been reported in this breed in Denmark (Möller, 7) and Germany (Wriedt, 11).

Weber and Ibsen (10) concluded tentatively that the character is transmitted as a single recessive gene. This explanation was not considered conclusive because the supporting evidence had been obtained as a report from a breeder and not from a controlled experiment.

Since Weber and Ibsen made the first report of the character in this country (1934), a controlled experiment has been conducted by the Department of Animal Husbandry at the Kansas Agricultural Experiment Station. The results of this investigation are summarized in this paper. Anatomical studies have indicated that the term "double-muscled" is actually a misnomer because there are definitely no extra muscles present in the body regions affected by the character. The term was not changed for discussion at this time because it is descriptive of the outward appearance of the character and is suitable for reference to the enlargement of the skeletal muscles of the pelvic limbs and the posterior lumbar region.

This paper includes a description of the character and an explanation of its mode of inheritance. Special attention has been given to the quantitative and qualitative aspects of this type of carcass.

A review of the literature has been made so that the description and the mode of inheritance of the double-muscled character may be better understood.

REVIEW OF THE LITERATURE

Double-muscled cattle have been known in Europe for many years. The early reports of the character offered no explanation of its mode of inheritance; however, these do include some observations well worth consideration.

Kaiser (1) observed double-muscled cattle in Europe, and the occurrence of the character in certain herds indicated that it was hereditary. Both double-muscled and normal calves had been produced by mating normal appearing bulls and cows; however, some of these normal cows produced double-muscled calves quite regularly even though they were mated to several different bulls. Variations of the expression of the character were observed by Kaiser.

According to Möller (7) the double-muscled character occurred very frequently in cattle of a Shorthorn crossing in Jutland. These animals were preferred for breeding purposes because of their meat qualities.

Pyndt (8) observed double-muscled cattle in Norway, and stated that there were variations in the expression of the character. He mentioned a double-muscled bull that sired double-muscled calves regularly when mated to normal cows. Some of the double-muscled cattle Pyndt observed were produced by mating normal appearing cows and bulls.

Wriedt (11) reported the occurrence of the double-muscled

character in a herd of cattle in Germany, and concluded that the character is transmitted as a single dominant gene which does not always manifest itself in the heterozygote. Evidently he assumed this factor to be incompletely dominant because of his segregation of homozygotes and heterozygotes in the data presented. Wriedt mentioned that he was uncertain of his recognition of the character when he first noted it because of its variability of expression.

According to Kronacher (3) the German breeders believed that the double-muscled character was due to a recessive factor because of its low frequency of occurrence. This explanation did not appear to be in accord with his observation of the occurrence of the character in a herd of cattle in that country. Kronacher mentioned a normal cow that produced double-muscled calves regularly even though she was mated to five different bulls which were normal in appearance. He did state that some of these bulls sired a few double-muscled calves when mated to other normal cows in the herd. Kronacher concluded that the character is transmitted as two dominant genes which require the presence of a third "release factor" in order to be expressed. Kronacher believed that his more complex hypothesis offered a more sound genetical explanation of the mode of inheritance of the character than did Wriedt's theory of variable dominance.

Hammond (4) mentioned the occurrence of the double-muscled character in the cattle of Europe and stated (without supporting evidence) that it was transmitted as a single recessive factor. Hammond did not indicate that the character occurred in the cattle

of Great Britain, although it occurs in our beef breeds that originated in England and Scotland.

Weber and Ibsen (10) presented evidence that the character appeared to be transmitted as a single recessive factor in a herd of purebred Herefords in Nebraska. These data were not considered to be conclusive because the information was obtained as a report from a breeder and not from a controlled experiment. Weber and Ibsen noted variations in the expression of the character and assumed these to be due to modifying factors; however, there was no information available to explain the mode of inheritance of these variations.

Kronacher's (3) and Wriedt's (11) observations of the occurrence of the double-muscled character did not provide data for a definite explanation of its mode of inheritance. The data presented in each case were based upon rather general observations. It was evident that a good many double-muscled cattle had normal appearing sires and dams. It is possible that some double-muscled animals may have shown the character to such a limited extent that they were not recognized as such.

MATERIAL AND METHODS

The data presented in this discussion were obtained from the records maintained on a controlled experiment conducted by the Department of Animal Husbandry, Kansas State College.

A double-muscled purebred Angus cow was obtained for this project in 1936. This cow was the foundation of a small herd maintained separately from the College purebred cattle. By in-

breeding, twenty-eight animals bearing relationships to the original cow were produced. Descriptions of these animals were recorded as the project progressed.

Some of the double-muscled animals were slaughtered for carcass examination. The anatomical and histological observations of the double-muscled character were made of these carcasses.

The project terminated in 1949.

RESULTS

Description of the Double-Muscled Character

Double-muscled cattle are abnormally wide in the rump and thigh regions. This extreme width extends forward to include the posterior portion of the loin region. The unusual development of the thigh muscles gives the hindquarters the appearance of arching to the rear. In addition, the rumps of double-muscled animals may be drooping and the twists lacking in depth; these faults, together with the large muscle development of the rump and thighs, give the hindquarters a very striking appearance. When viewed from the side, the rump and thighs appear to resemble a horse. Deep grooves between the thigh muscles are conspicuous beneath the skin. These grooves remain very noticeable although the animals are in excellent condition.

The description and photograph presented by Kronacher (2) of the character termed "doppellender" in Germany provide positive proof that it is phenotypically the same character as that termed "double-muscled" by Weber and Ibsen.

The character develops during the prenatal growth of the calf, so it is present at the time of birth (Plate IV). It was noted that the development of the hindquarters of double-muscled male calves may be more pronounced than those of females at this time; however, the character becomes just as evident in females by the time they are a few weeks old. There has been no evidence that the character is associated with sex or influenced by castration.

The large hindquarters of the double-muscled calves caused difficulties at parturition in some cases. Both the double-muscled calf, no. IV' (Plate XII), and its dam died because the hindquarters of this calf were too large to pass through the pelvic inlet of the cow. Kronacher (3) and Wriedt (11) have noted such occurrences previously.

Wriedt (11) and Hammond (4) stated that double-muscled females are often sterile or at least poor producers. The double-muscled cow (Plate I) produced eleven calves during the thirteen years she was maintained for observation. The double-muscled female calf (Plate VI), that was slaughtered for anatomical studies, had a normally developed reproductive system for a calf of that age. All of the cows used in the experiment were regular breeders.

Malkus (6) described double-muscled cattle as suffering from pelvic distortions. No pelvic abnormalities were noted in the double-muscled animals which were slaughtered for examination.

There were no indications in this experiment that the double-muscled character produced any special alteration of body size.

Some of the animals produced were somewhat small, but inbreeding probably had some influence in relation to general body size. The double-muscled cow (Plate I) showed the character to a marked degree. She weighed approximately 1300 pounds when in good condition.

Most of the double-muscled animals produced here did appear to be rather low-set, and some individuals were quite coarse about the shoulders. Oftentimes the backs were low in the middle, and the loins and hips were high or prominent. These characteristics are shown in the photograph of a bull (Plate II) that was produced and used in this experiment.

All of the double-muscled cattle produced here showed the character to a marked degree. Variations in the expression of the character have been observed in different herds, and in some cases it might be difficult to distinguish it from a normal thick muscled condition. The presence of the grooves between the muscles of the thigh serves as the most positive means of identifying the character.

None of the animals classified as heterozygotes (Plate III) showed any indication of being double-muscled.

Dr. W. M. McLeod, Department of Veterinary Medicine, Kansas State College, examined the carcasses of two double-muscled steers and two double-muscled calves. He concluded that the double-muscled character consisted of an enlargement of the skeletal muscles of the pelvic limbs and posterior lumbar region. The enlargement was most pronounced in the rump and thigh muscles. Although there was no definite termination of the enlargement of the muscles of

the loin region, the posterior half appeared to be all that was affected by the character. In some cases the *M. longissimus dorsi* muscle was somewhat large in the anterior part of the loin and in the rib regions.

The same skeletal muscles are probably enlarged in animals showing the character to only a limited degree. No animals of this description have been examined, however.

A double-muscled male calf that was born dead was photographed to show the appearance of the character (Plate IV). Plate V provides lateral and medial views of the pelvic limb. The muscles of the loin region are exposed and numbered in each photograph also. All of the skeletal muscles identified in these photographs appeared to be enlarged.

A double-muscled female calf and a normal male calf were slaughtered for anatomical comparisons. The double-muscled calf was 43.75 percent inbred according to Wright's formula (12). This calf was a thick-fleshed individual, and the development of its hindquarters was very pronounced. The normal calf was the product of a Holstein cow by an Angus bull. Although this calf lacked some of the thickness of fleshing characteristic of most beef calves of that age, it was used because it was the only calf available at the time the comparison was made.

The double-muscled calf was six weeks old and the male calf was one week younger at the time they were killed. Plates VI and VII provide rear, front, and side views of these two animals as they appeared at this time. The double-muscled calf was partially clipped so that the development of the hindquarters could be ob-

served more plainly.

The carcass of the double-muscled calf showed a very striking development of the hindquarters (Plate VIII).

One pelvic limb of each calf was photographed at the same distance. Both lateral (Plate IX) and medial (Plate X) views are shown. The muscles of the lumbar region which appear to be affected by the character are included in the photographs.

Plate XI provides views of corresponding cross-sectional cuts through the round and posterior loin regions of each carcass. The section through the round of the normal calf was cut somewhat higher and the bone is larger because it was nearer to the hip joint.

The areas of round cuts from the double-muscled and normal calf were 359 and 190 square centimeters respectively. The area of the loin cut from the double-muscled calf was 106 square centimeters and that of the loin cut from the normal calf was 57 square centimeters.

Quantitative analyses of the muscle segments of the hindquarters of each calf indicated very little difference in protein, fat, moisture, and ash contents. The percent of fat in the muscle segments of the double-muscled calf was slightly higher. These analyses are summarized in Table 1.

Table 1. Summary of the quantitative analyses of the muscle segments from the round of the normal and double-muscled calf.

	Normal calf	Double-muscled calf
pH	5.73	5.68
Protein	23.3%	22.9%
Fat	2.4%	3.1%
Moisture	75.3%	75.3%
Ash	1.34%	1.40%
Total	102.34%	102.70%

Dr. L. M. Roderick, Department of Veterinary Medicine, Kansas State College, made histological studies of muscle tissue from the hindquarters of two double-muscled steers and one double-muscled calf. These tissues were compared with corresponding tissues from normal animals of approximately the same age. Dr. Roderick reported that he could detect no abnormal development of the cells of the double-muscled animal's muscle tissue. The cells of these tissues did not appear to be enlarged so there was no evidence of hypertrophy. Dr. Roderick concluded that the enlargement of the muscles was probably due to a condition of hyperplasia or an increase in the number of cells of the muscles affected by the double-muscled character.

EXPLANATION OF PLATE I

Side and rear views of the double-muscled cow used in the experiment. This cow is number I² on the pedigree chart, Plate XII.

PLATE I

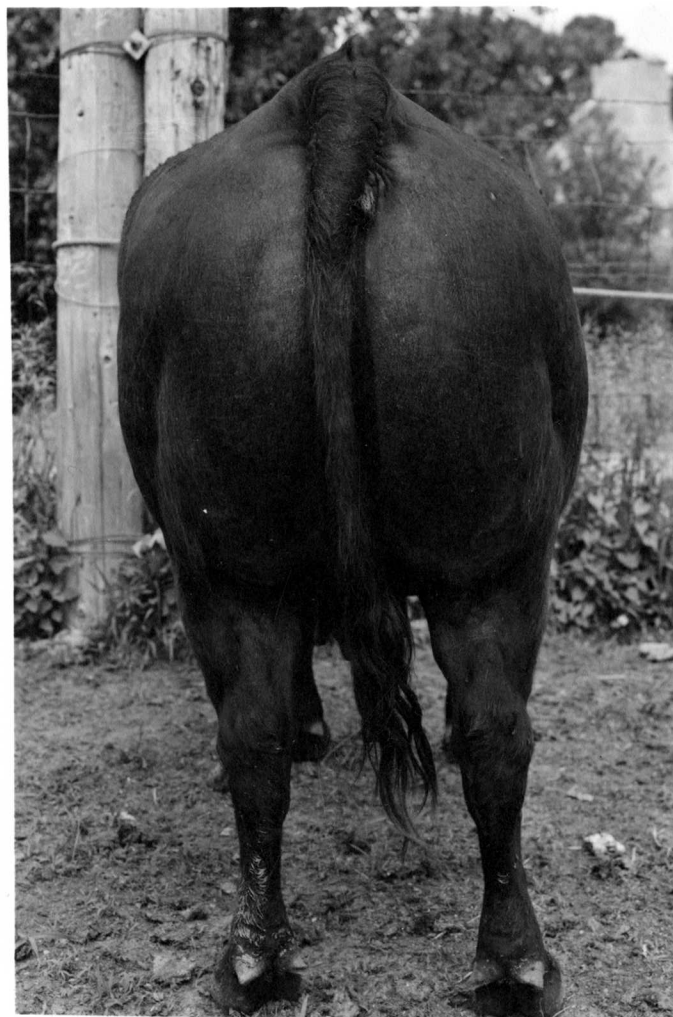

EXPLANATION OF PLATE II

Side and rear views of a double-muscled bull produced and used in the experiment. This bull is number III¹³ on the pedigree chart, Plate XII.

PLATE II

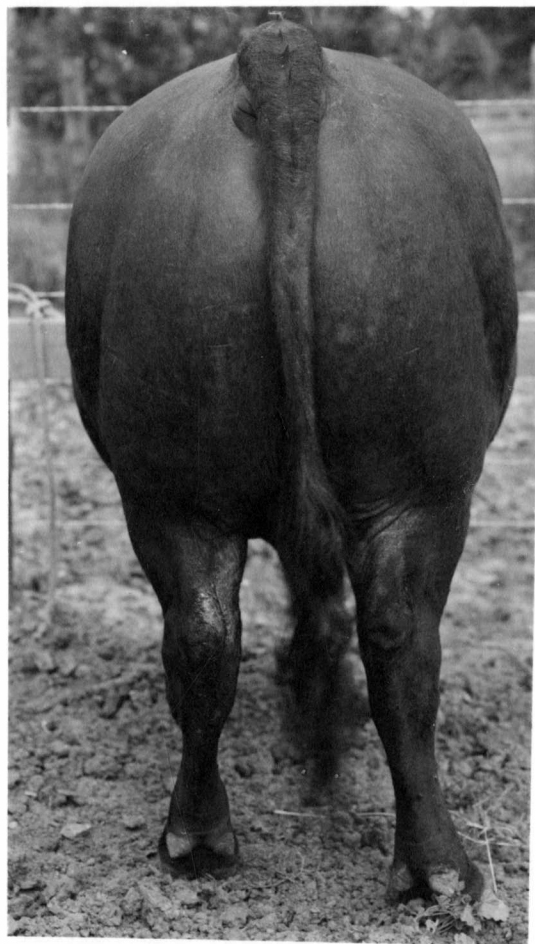

EXPLANATION OF PLATE III

Hindquarters of a heterozygous cow produced in this experiment. The bottom photograph shows the same cow standing beside a double-muscled cow. The normal appearing cow is number II⁵ on the pedigree chart, Plate XII.

PLATE III

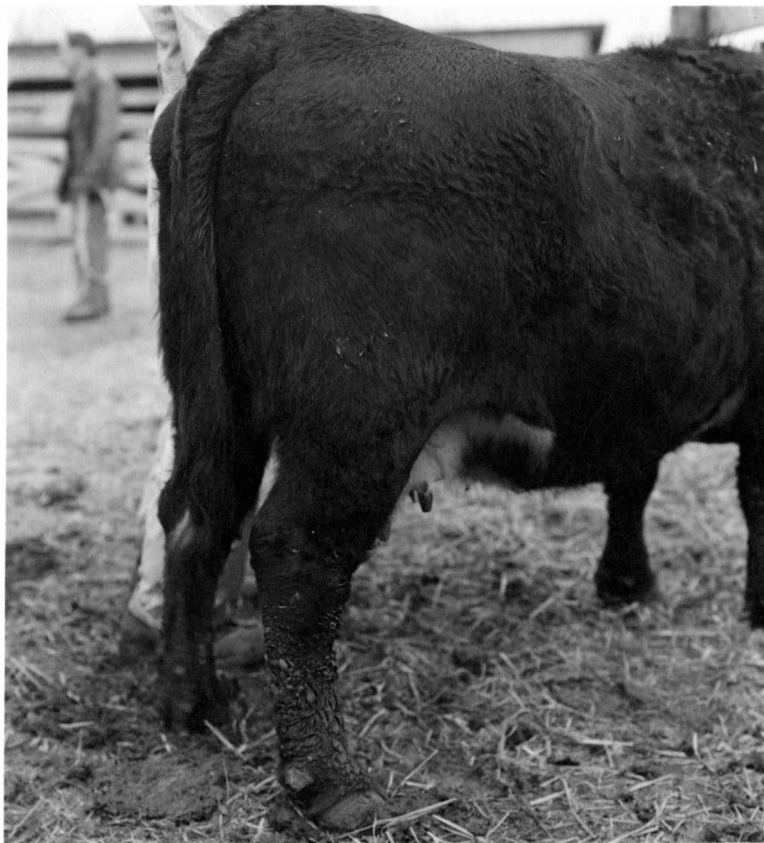

EXPLANATION OF PLATE IV

Hindquarters of a double-muscled calf that was born dead. This calf is number V¹ on the pedigree chart, Plate XII.

PLATE IV



EXPLANATION OF PLATE V

Hindquarters of same calf on Plate IV. The skin and cutaneous tissue have been removed. The muscles are numbered for identification.

A. Lateral view of pelvic limb and lumbar region.

1. M. Quadriceps femoris (Vastus lateralis).
2. M. Tensor fascia lata.
3. M. Glutens medius.
4. M. Longissimus dorsi.
5. M. Biceps femoris.
6. M. Semitendinosus.
7. M. Semimembranosus.
8. M. Gastrocnemius.
9. M. Extensor digitalis lateralis.
10. M. Peroneus tertius.
11. M. Extensor digitalis longus.
12. M. Flexor digitalis profundus.
(between 8 and 9)

B. Medial view of pelvic limb and sub-lumbar region.

1. M. Psoas major.
2. M. Psoas minor.
3. M. Iliacus.
4. M. Sartorius.
5. M. Quadriceps femoris (Vastus medialis).
6. M. Fensor fascia lata.
7. M. Pectineus.
8. M. Gracilus.
9. M. Semimembranosus.
10. M. Semitendinosus.
11. M. Gastrocnemius.

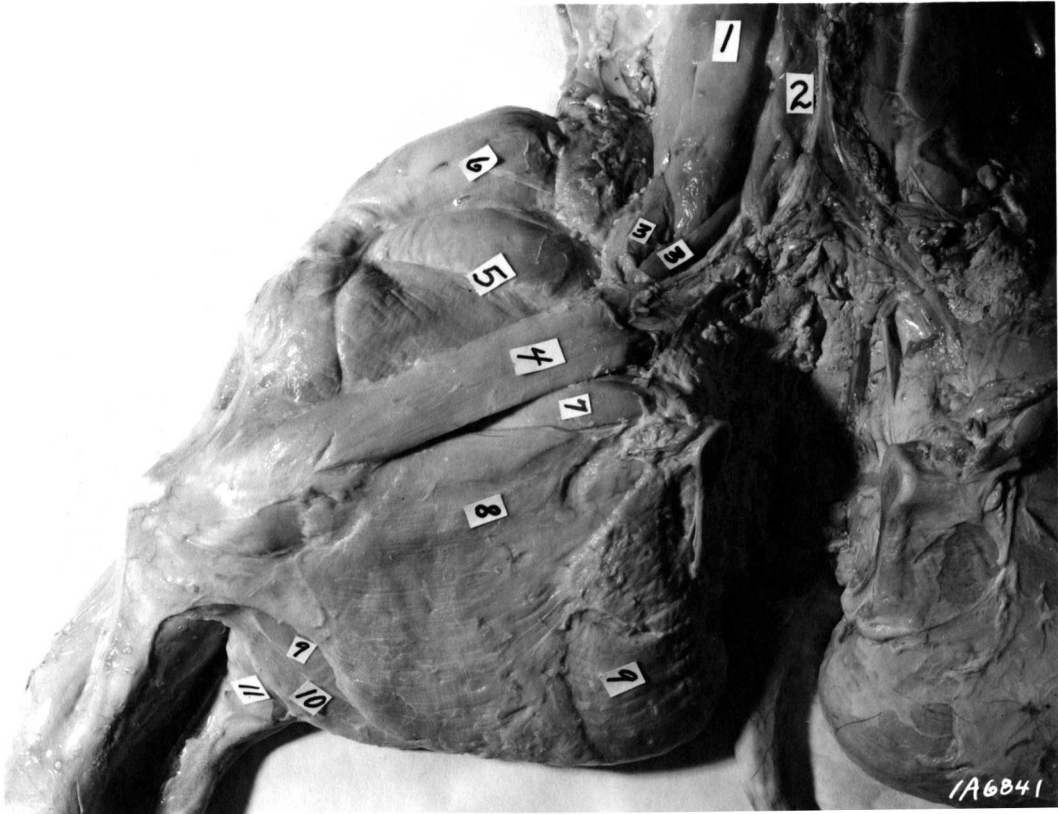

1A6841

EXPLANATION OF PLATE VI

Rear and front views of the double-muscled calf (at left) and normal calf that were slaughtered for anatomical comparison. The double-muscled calf is number V² on the pedigree chart, Plate XII.

PLATE VI

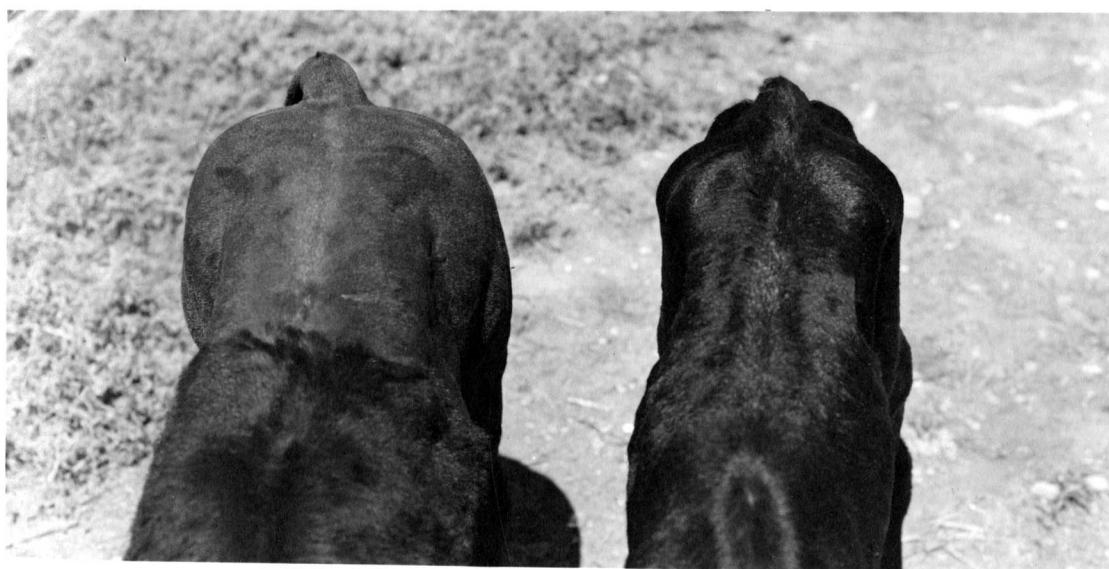

EXPLANATION OF PLATE VII

Side view of the double-muscled calf (at left)
and normal calf that were slaughtered for anatomical comparison.

PLATE VII



EXPLANATION OF PLATE VIII

Carcasses of the double-muscled and normal calves. The double-muscled calf's carcass is at the left in the photograph.

PLATE VIII

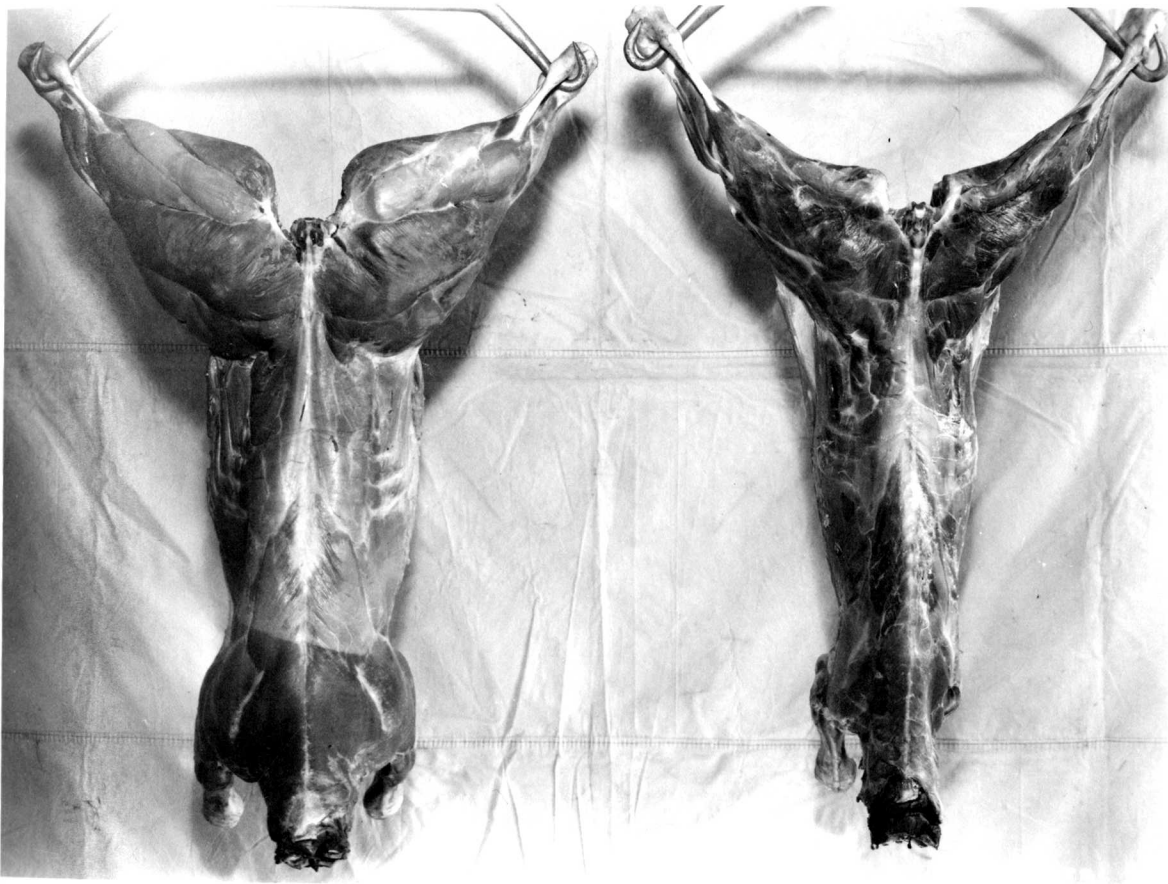

EXPLANATION OF PLATE IX

Lateral views of the pelvic limbs and lumbar regions of the double-muscled calf (at top) and normal calf. The cutaneous tissue has been removed, and the muscles have been numbered for identification.

1. M. Quadriceps femoris (Vastus lateralis).
2. M. Tensor fascia lata.
3. M. Gluteus medius.
4. M. Longissimus dorsi.
5. M. Biceps femoris.
6. M. Semitendinosus.
7. M. Semimembranosus.
8. M. Gastrocnemius.
9. M. Extensor digitalis lateralis.
10. M. Peroneus tertius.
11. M. Extensor digitalis longus.
12. M. Flexor digitalis profundus.

PLATE IX

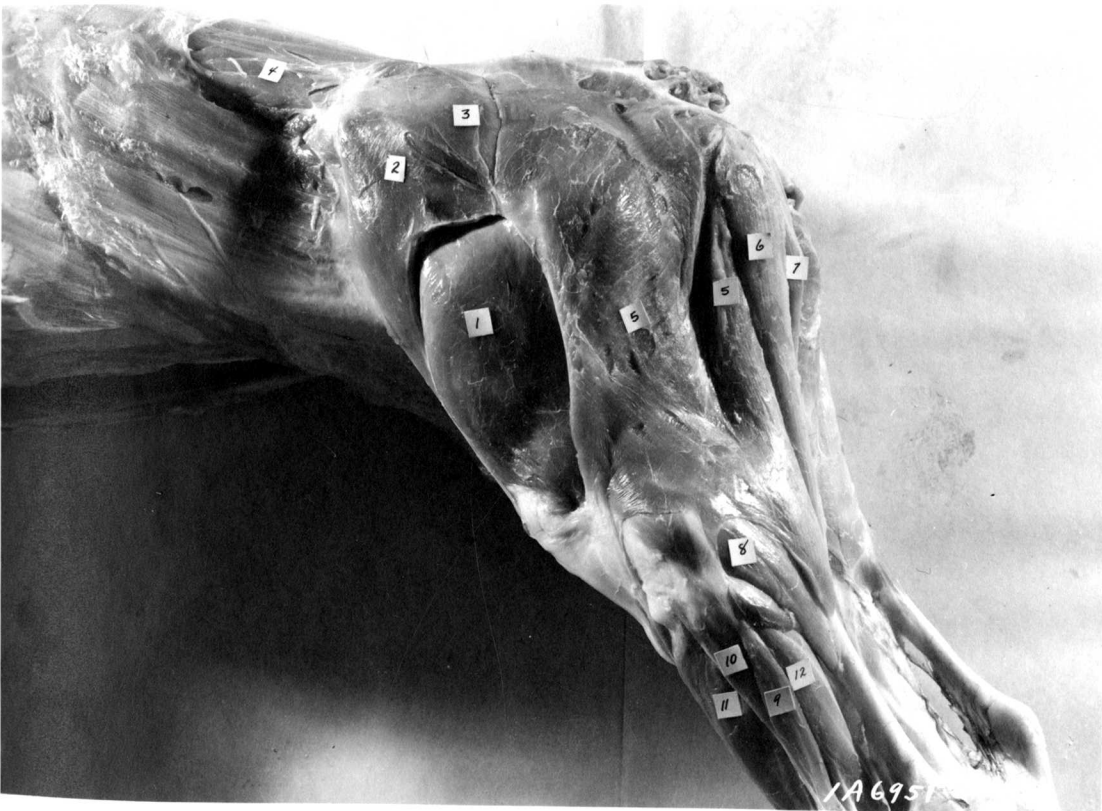
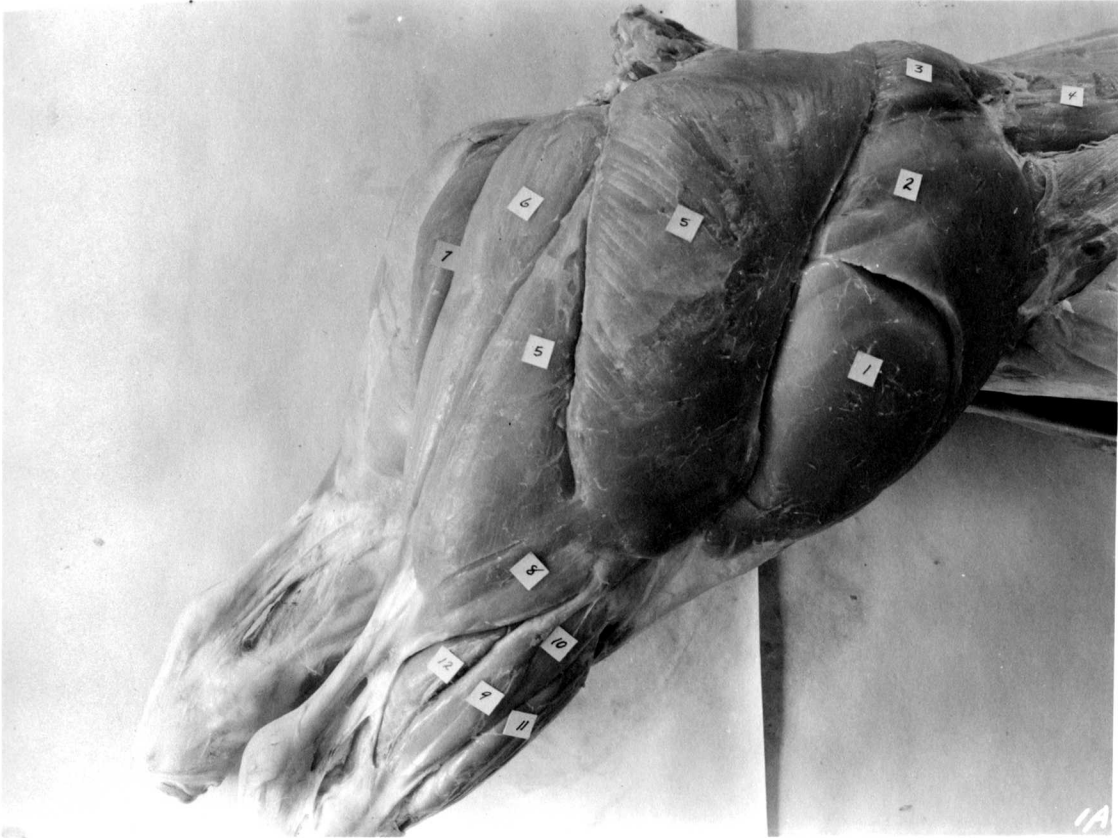

EXPLANATION OF PLATE X

Medial views of the pelvic limbs and sub lumbar regions of the double-muscled calf (at top) and normal calf. The cutaneous tissue has been removed, and the muscles have been numbered for identification.

1. M. Psoas major.
2. M. Psoas minor.
3. M. Iliacus.
4. M. Sartorius.
5. M. Quadriceps femoris (Vastus medialis).
6. M. Tensor fascia lata.
7. M. Pectineus.
8. M. Gracilis.
9. M. Semimembranosus.
10. M. Semimembranosus.
11. M. Gastrocnemius.
12. M. Semitendinosus (exposed on normal animal only).

PLATE X

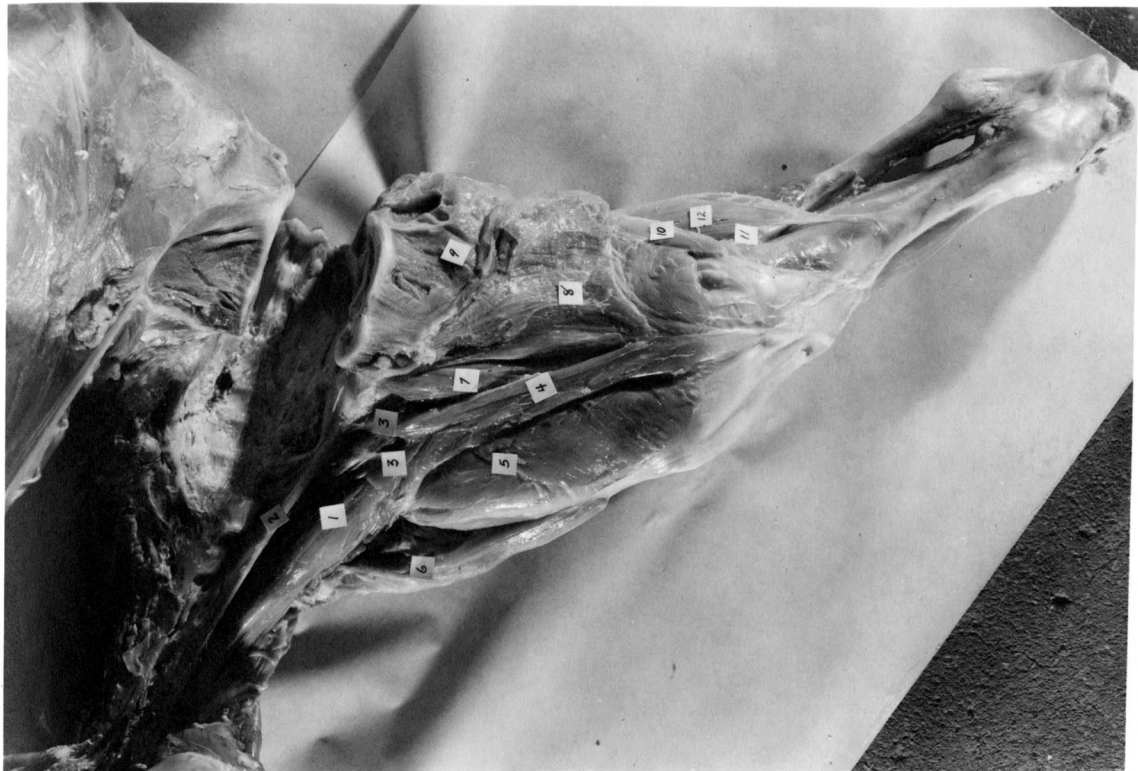

EXPLANATION OF PLATE XI

- A. Corresponding cuts from the posterior loin region of the normal (at top) and double-muscled calf. The muscles are numbered for identification.

1. M. Psoas major.
2. M. Longissimus dorsi.
3. M. Multifidus dorsi.

- B. Corresponding cuts from the round of the normal (at top) and double-muscled calf.

1. M. Vastus intermedius)
2. M. Rectus femoris)
3. M. Vastus lateralis) Quadriceps femoris.
4. M. Vastus medialis)
5. M. Sartorius.
6. M. Ilio psoas (Psoas major plus Iliacus).
7. M. Gracilus.
8. M. Semimembranosus.
9. M. Semitendinosus.
10. M. Biceps femoris (3 sections).
11. M. Tensor fascia lata.

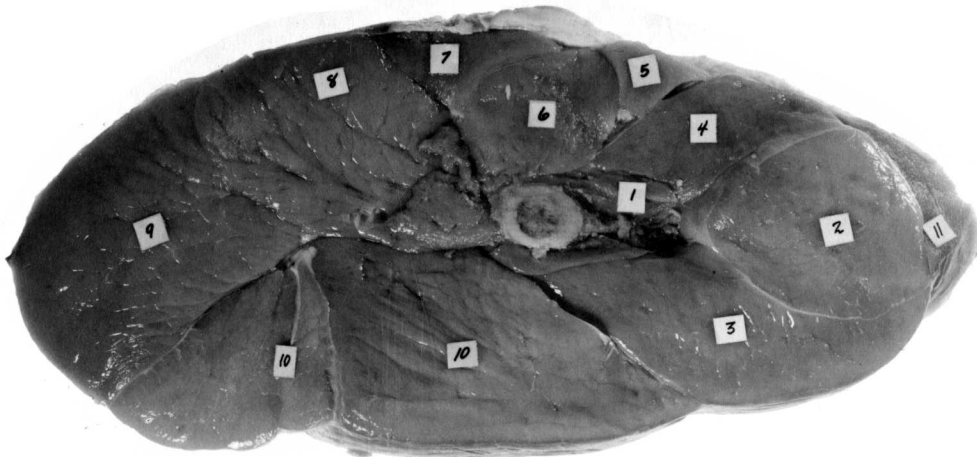
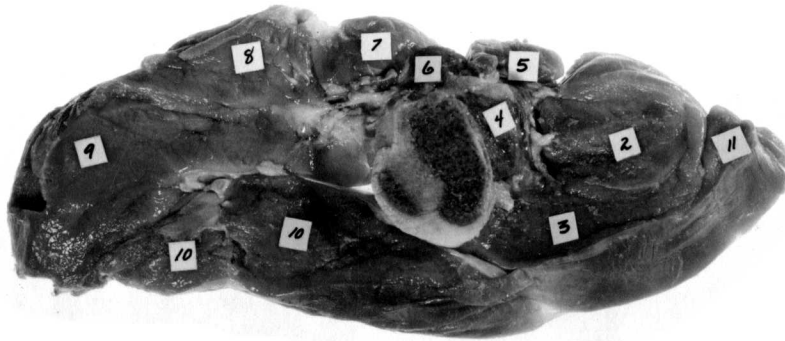
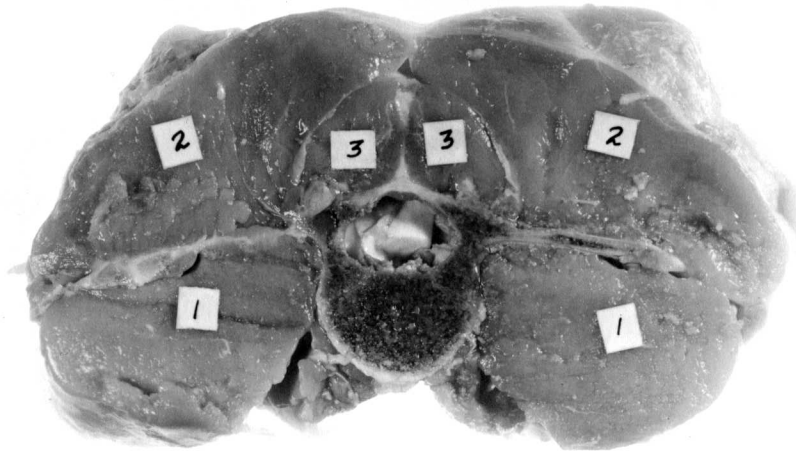
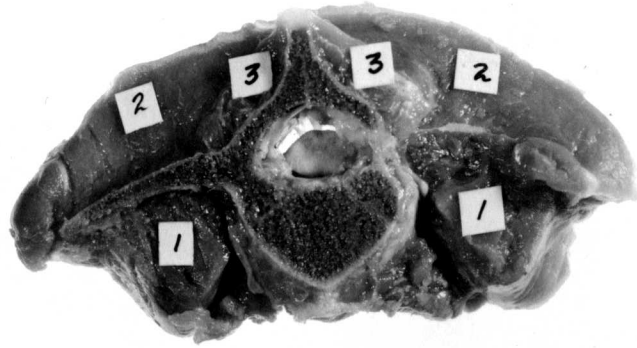

Mode of Inheritance of the Double-Muscled Character

The matings that were made and the animals that were produced in this experiment are shown on a pedigree chart (Plate XII). All of the animals produced bear some relationship to the original double-muscled cow, no. I² (Plate XII). Some of them were highly inbred.

The original cow was obtained from a purebred Aberdeen-Angus herd in which the character occurred quite frequently. No double-muscled animals had been maintained for breeding purposes because the breeder considered the character undesirable.

All of the bulls used in the experiment not related to the double-muscled cow were purebred animals which were used as sires in the College purebred herds. The ancestry and breeding records of these bulls and the Holstein cow, no. II² (Plate XII), gave no indication that these animals carried the gene for the double-muscled character.

An analysis of the data obtained from this experiment and previous observations of the occurrence of this character made by Weber and Ibsen indicate that the mode of inheritance of the double-muscled character is best explained by assuming that it is transmitted as a single autosomal recessive, designated as dm for convenience of discussion. The gene for normal muscle development (Dm) is completely dominant to its recessive allelomorph. None of the animals classified as heterozygotes (Dm dm) showed any indication of being double-muscled. The two animals

EXPLANATION OF PLATE XII

Pedigree chart of all animals produced in
this experiment.

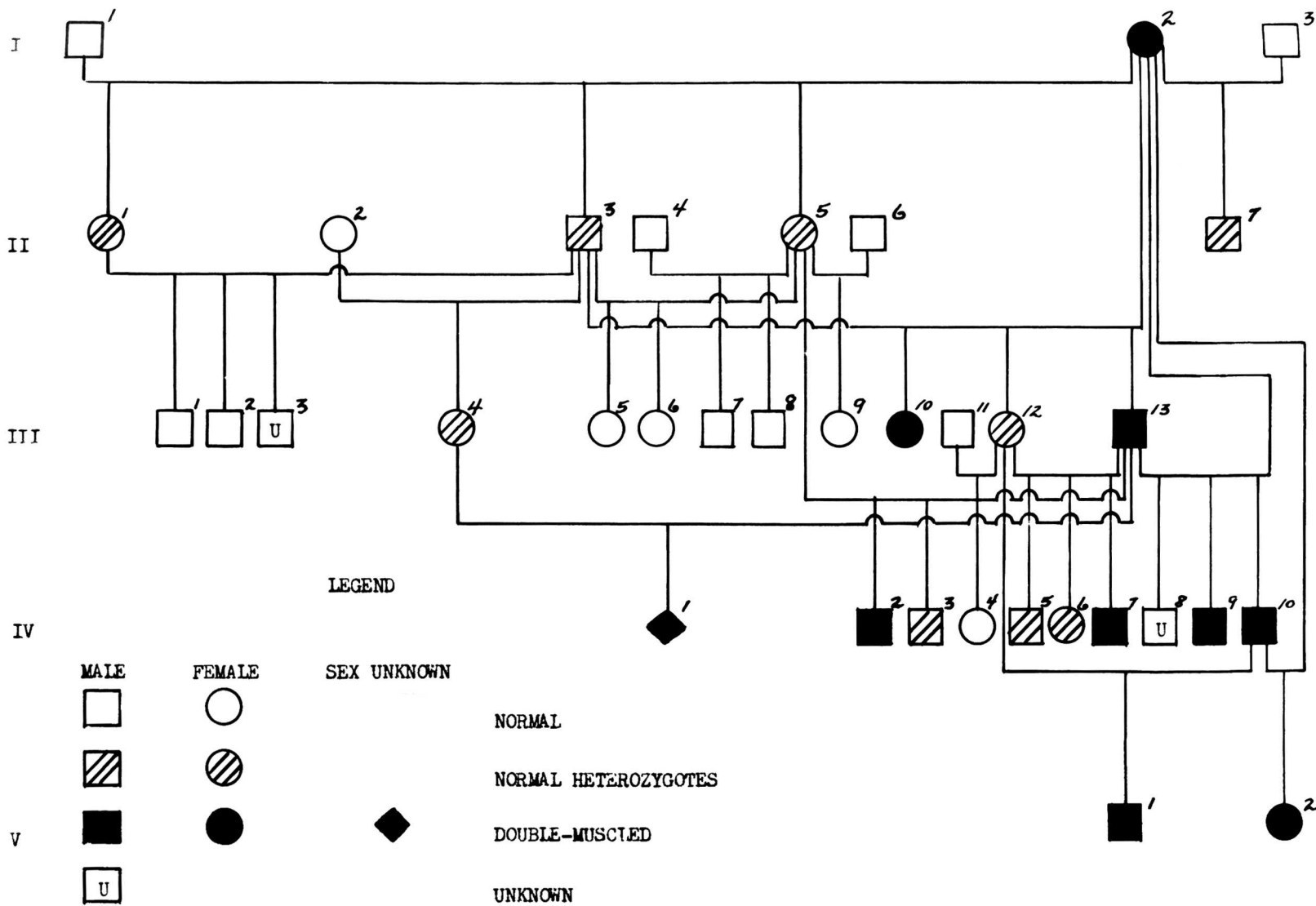

PEDIGREE CHART OF THE DOUBLE-MUSCLED CHARACTER

PLATE XII

classified as "unknown" were still-born and were disposed of before a description was obtained.

The double-muscled cow (dm dm) produced four normal (Dm dm) calves from matings with two normal bulls (Dm Dm). She produced two double-muscled (dm dm) and one heterozygous calf (Dm dm) from matings with a heterozygous son (Dm dm).

Three heterozygous daughters (Dm dm) of the double-muscled cow were mated to a heterozygous bull (Dm dm) to produce four normal calves (Dm --). The description of the fifth calf produced by this same type of mating was unknown.

Two of these heterozygous daughters (Dm dm) were mated to unrelated normal bulls (Dm Dm) to produce four normal calves (Dm --). These same two heterozygous cows (Dm dm) produced three double-muscled (dm dm) and three heterozygous calves (Dm dm) from matings with double-muscled bulls (dm dm).

A heterozygous cow (Dm dm), whose sire was a heterozygous bull (Dm dm) and whose dam was a normal Holstein cow (Dm Dm), gave birth to a double-muscled calf (dm dm) when mated to a double-muscled bull (dm dm). Both the cow and calf died when the calf was born, and the sex of this calf was not recorded.

Four calves were produced by mating the double-muscled cow (dm dm) to double-muscled bulls (dm dm). One calf was still-born and its description was unknown. The other three were double-muscled (dm dm).

Although the number of animals produced in this experiment is relatively small, the results indicate that the double-muscled

character is transmitted as a single autosomal recessive. The deviations between the number of types of animals produced and the number of types expected from the various matings are not significant (Table 2). The one unknown calf produced by mating two double-muscled individuals should have been double-muscled. No double-muscled calves were produced from parents both of which were heterozygous (Dm dm). There were but four calves produced from such matings. The original double-muscled cow was known to have normal parents.

Six double-muscled males and two double-muscled females were produced in this experiment; thus, the character is expressed in both sexes.

The information obtained from this investigation did not provide data for a genetical analysis of the variations of the expression of the double-muscled character. All of the double-muscled animals produced were inbred and showed the character to a marked degree.

These data do not provide conclusive evidence that the double-muscled character is transmitted as a recessive factor. This explanation does explain the occurrence of the character in the cattle produced in this experiment and in a purebred herd observed by Weber and Ibsen (10). The occurrence of the character in another herd in which it was sought to be eliminated by disposing of all double-muscled animals indicated that it was probably due to a recessive factor.

The occurrence of the character in the herds observed by Wriedt (11) and Kronacher (3) might be explained by assuming it

Table 2. Crosses made in the double-muscled cattle experiment, assuming the character to be transmitted as a single recessive gene.

Matings	<u>Offspring produced</u>			
	Double-muscled		Normal	
	observed	expected	observed	expected
1. <u>dm dm</u> ♀ x <u>Dm Dm</u> ♂			4	4
2. <u>dm dm</u> ♀ x <u>Dm dm</u> ♂	2	1.5	1	1.5
3. <u>dm dm</u> ♀ x <u>dm dm</u> ♂	3	3		
4. <u>Dm dm</u> ♀ x <u>Dm dm</u> ♂	+ 1 unknown	1	4	3
	+ 1 unknown			
Chi square = .33 Probability .50 - .70				
5. <u>Dm dm</u> ♀ x <u>dm dm</u> ♂	4	3.5	3	3.5
Total (2 + 5)				
<u>Dm dm</u> x <u>dm dm</u>	6	5	4	5
Chi square = .10 Probability approximately .75				
6. <u>Dm dm</u> ♀ x <u>Dm Dm</u> ♂			4	4
7. <u>Dm Dm</u> ♀ x <u>Dm dm</u> ♂			1	1

to be due to a recessive factor providing a large number of the animals which were described as normal were heterozygous.

Characteristics of the Double-Muscled Carcass

Packers have shown discrimination against double-muscled cattle primarily because the carcasses of such animals lack fat covering, both internal and external. Weber and Ibsen (10) stated that the meat from this type of carcass had a tendency to become dry during storage and transit because of insufficient fat covering.

Prof. William J. Loeffel (5), Department of Animal Husbandry, Nebraska University, informed the author that he has slaughtered several double-muscled animals and has observed others in packing house coolers. He described these carcasses as lacking fat covering and stated that these animals are usually discounted on the market, although he knows some buyers who have standing orders for them whenever they turn up. He described the meat from these carcasses as being pale and quite watery, and mentioned that he had observed it to be lacking in flavor; however, it is considered to be very tender.

Shrode and Lush (9) stated that they had been informed by a few men who recognized the character that the meat from these animals is tender and richly flavored. Additional information indicated that the carcasses of double-muscled cattle are highly demanded by a few connoisseurs who are able to recognize the character.

Double-muscled cattle are considered to be excellent meat

animals in Germany (Kronacher, 3).

Two of the double-muscled steers produced in this experiment were slaughtered and examined by Prof. David L. Mackintosh, Department of Animal Husbandry, Kansas State College. He has also observed a number of double-muscled animals in packing house coolers. The carcasses of these animals definitely lacked internal and external fat covering. In addition to these deficiencies, he noted that the cuts obtained from these carcasses had very little or no marbling, especially those from the hindquarters where the character is most pronounced. The meat from these animals was tender and appeared to be quite watery when cut.

The meat from the carcasses of the two animals which were produced in this project had a very coarse texture. In addition it lacked physical compactness, and numerous gaps were present between the muscles making up the various cuts. These characteristics are illustrated in the photograph of the carcass and round cut of the first steer that was slaughtered (Plates XIII and XIV).

A double-muscled steer calf and a normal purebred Angus calf of the same age were selected to be fed and slaughtered for carcass comparisons. The double-muscled steer was 37.5 percent inbred according to Wright's formula (12). A segregation of the effects of inbreeding and those of the double-muscled character upon the steer's carcass was not possible. This comparison was made to illustrate the usual characteristics that Prof. Mackintosh has observed to be associated with this type of carcass.

Both calves were creep fed prior to weaning. At six months

EXPLANATION OF PLATE XIII

Carcass of the first double-muscled steer
slaughtered for examination. This animal is
no. IV² on the pedigree chart, Plate XII.

PLATE XIII



EXPLANATION OF PLATE XIV

Round of the first double-muscled steer slaughtered for carcass examination. This round is from the carcass shown on Plate XIII.

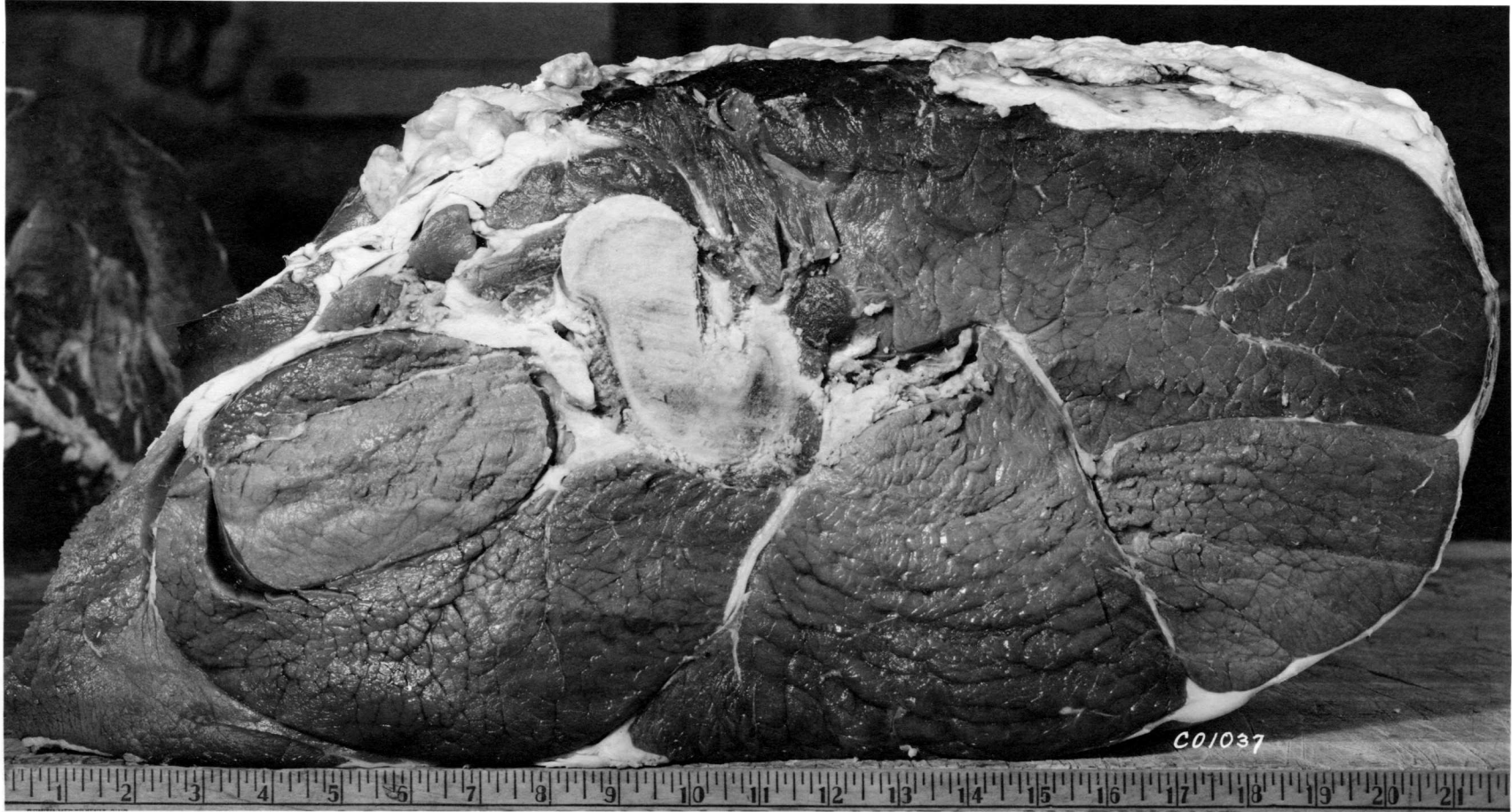

PLATE XIV

of age they (Plate XV) were placed on a full ration of grain along with a group of purebred steers from the College herds. The steers were full fed for approximately twelve months. This period should have assured maximum finish as provided by usual feed lot management. Both animals progressed satisfactorily during this time, so there was no reason to believe that either animal had an advantage that might have favorably influenced its performance in the feed lot.

The two steers were slaughtered at eighteen months of age (Plate XVI). The double-muscled steer weighed 970 pounds, and the normal steer weighed 1100 pounds at this time.

The double-muscled steer's dressing percent was 66.70 percent and that of the normal steer was 63.45 percent. The normal steer had a heavier hide and more paunch fill; these factors appeared to account for the difference in dressing percent. The double-muscled steer did have a high dressing percent, although his carcass definitely lacked finish compared to carcass of the normal steer. The differences in the development of the hindquarters, fat covering, and marbling of the rib eye muscle are shown on Plate XVII.

The right side of each carcass was broken down into wholesale cuts after aging one week in a cooler. These data are summarized in Table 3.

The hindquarter of the double-muscled steer was proportionally heavier than was that of the normal steer. The rump and round weights exceeded those of the normal steer even though the double-muscled steer's carcass was smaller. These differences

EXPLANATION OF PLATE XV

Rear and side views of the normal and double-muscled steers at six months of age. The double-muscled steer is no. IV⁹ on the pedigree chart, Plate XII. The double-muscled steer is at the right in both photographs.

PLATE XV



EXPLANATION OF PLATE XVI

Rear and side views of the normal and double-muscled steers at eighteen months of age, just prior to slaughter. The double-muscled steer is at the right in both photographs.

PLATE XVI



EXPLANATION OF PLATE XVII

**Carcasses of the double-muscled and normal steers.
The left side of each carcass has been ribbed down
to show the rib eye muscle. The double-muscled
steer's carcass is at the left in the photograph.**

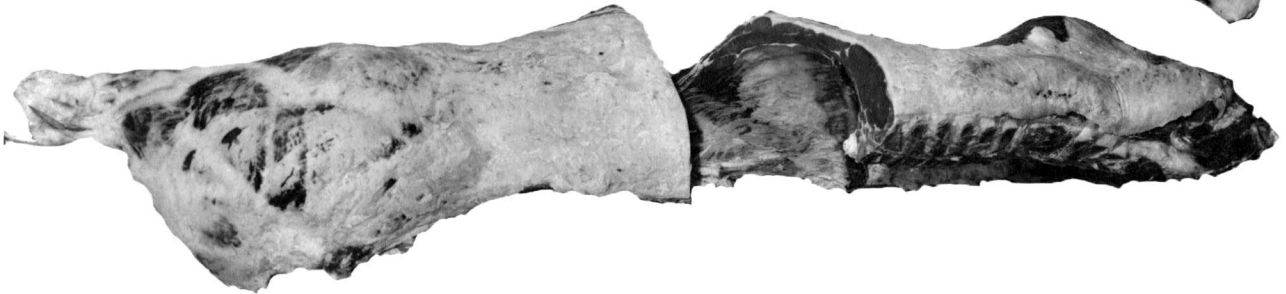
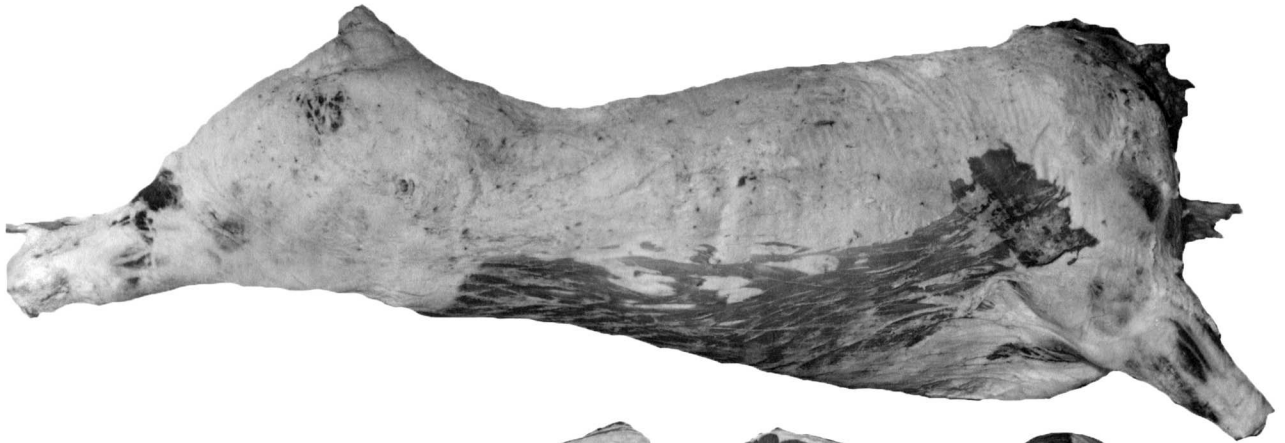

Table 3. Comparative wholesale break-down of the right side of the double-muscled and normal steers' carcasses.

	: <u>Double-muscled</u> :		: <u>Normal</u> :	
	: pounds :	Percentage	: pounds :	Percentage
Right side	308.		339.	
Hindquarter	150.	48.7 % of side	158.	46.6 % of side
Loin	47.	31.33% of quarter	53.	33.54% of quarter
Flank	15.8	10.53% of quarter	22.5	14.24% of quarter
Rump	15.1	10.06% of quarter	12.5	7.91% of quarter
Round	66.25	44.16% of quarter	61.5	38.92% of quarter
Forequarter	158.	51.29% of side	181.	53.39% of side
Rib	31.	19.62% of quarter	33.	18.23% of quarter
Plate	29.	18.35% of quarter	35.	19.33% of quarter
Shank	8.9	5.63% of quarter	9.2	5.08% of quarter
Chuck	83.	52.53% of quarter	92.	50.82% of quarter
Brisket	10.	6.32% of quarter	14.7	8.12% of quarter

in carcass proportions were quite obvious in the live animals and in their carcasses.

The loin of the normal steer was proportionally heavier than that of the double-muscled steer. The thicker covering of fat and the larger amount of intermuscle fat of the normal steer's loin appeared to account for this difference.

The flank of the double-muscled steer was proportionally lighter than that of the normal steer.

The differences of fat covering, intermuscle fat, marbling, and muscle development of the wholesale cuts are shown on Plates XVIII and XIX. The characteristics which Prof. Mackintosh noted to be associated with the double-muscled character are very evident in these photographs.

The Department of Home Economics, Kansas State College, prepared samples from the inside round, outside round, rib, and loin of each carcass for palatability comparisons. Cooking losses, press fluid volumes, and shear values were determined for each cooked sample. The press fluid volumes were obtained by the standard method using the Carver laboratory press. The press fluid was centrifuged to determine its serum and fat content. Shear values were determined with a Warner-Bratzler shear. These procedures provided mechanical estimations of the juiciness and tenderness qualities of the cooked samples.

A committee of five judges scored the samples for palatability. Aroma, flavor of the lean, tenderness, and juiciness were the factors considered. The scoring was done on a basis of ten

EXPLANATION OF PLATE XVIII

A. Loins of normal steer's carcass (at left)
and double-muscled steer's carcass. The ex-
posed surfaces are at the porterhouse steak
regions.

B. Rounds of normal steer's carcass (at left)
and double-muscled steer's carcass.

PLATE XVIII

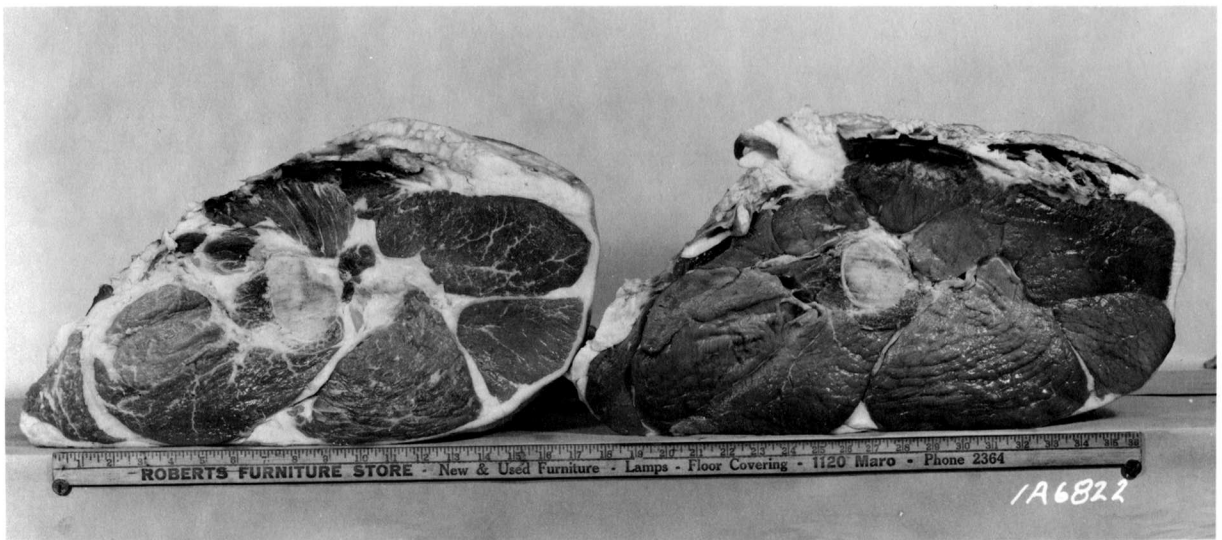
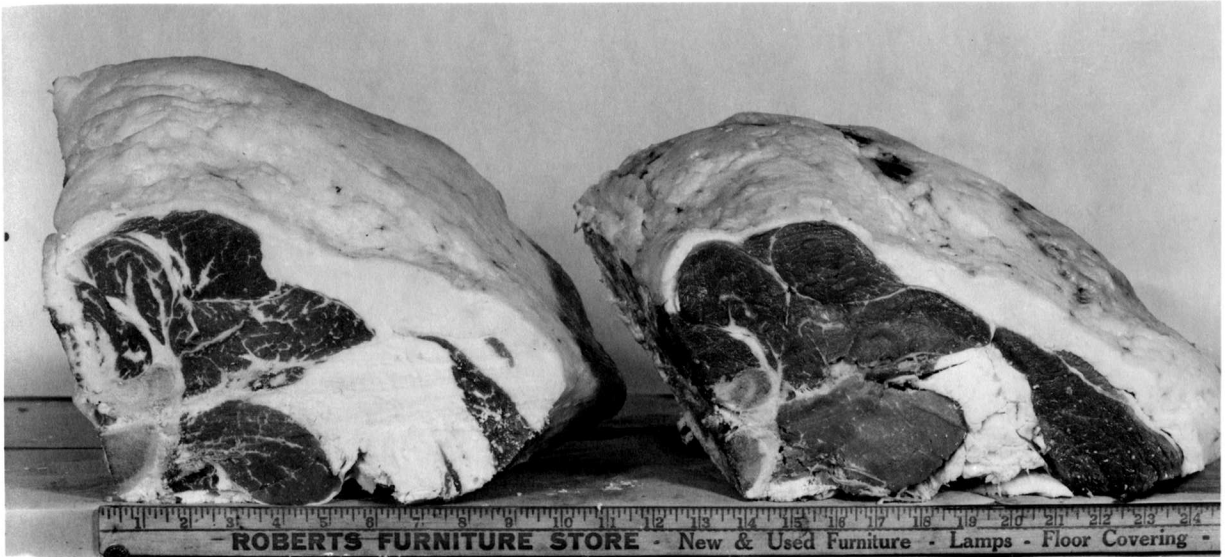

EXPLANATION OF PLATE XIX

A. Rib cuts of normal steer's carcass (at left)
and double-muscled steer's carcass.

B. Wedge-bone sirloin cuts from normal steer's
carcass (at left) and double-muscled steer's
carcass.

PLATE XIX



points. The higher values represent the more desirable score.

The results of this palatability study are summarized in Table 4.

The juiciness and tenderness qualities of the cooked samples as indicated by the press fluid volumes and shear values are in accord with the average scores designated by the committee of judges. Although the palatability measurements varied in favor of each carcass, some tendencies were observed.

All samples scored high with considerable uniformity in respect to aroma. Except for the loin steaks, which were scored about the same, the flavor of the lean of the samples from the normal steer were scored higher. Tenderness of the prepared samples appeared to alternate in favor of each carcass; however, the outside round sample of the double-muscle steer was scored as being rather deficient in this respect. Juiciness alternated in favor of each carcass also. The inside round of the double-muscle steer did receive a low score for this factor. The samples from the normal steer's carcass had a higher percent of cooking loss.

Muscle segments of the rib eye, inside round, and outside round were analyzed by the Chemistry Department, Kansas State College. These data are summarized in Table 5.

Table 4. Summary of cooking losses, press fluid volumes, shear values, and palatability scores of the meat samples from the double-musclcd and normal steers.

	: Inside round :		: Outside round :		: Rib roast :		: Loin steak :	
	: Double-:		: Double-:		: Double-:		: Double-:	
	: Normal	: musclcd:	: Normal	: musclcd:	: Normal	: musclcd:	: Normal	: musclcd:
Method of cookery	Broil	Broil	Braise	Braise	Roast	Roast	Broil	Broil
Total cooking loss - %	30	29	31	23	24.9	21.6	30	23
Drip loss - %	8	3.5	--	--	12	5.9	9	13
Volatile loss - %	22	25.3	--	--	12.9	15.6	21	9.8
Press fluids, ml.:								
Serum	5.3	6.6	5.8	8.3	6.4	7.4	3.4	1.9
Fat	3	.6	.1	.3	1.9	.3	1.4	2.2
Total	8.4	7.2	6.8	8.6	8.3	7.8	4.8	4.1
Shear value - pounds	13.3	11.7	15.6	16.5	10.6	17.8	17.2	13.8
Palatability scores:								
Aroma	7.8	7.8	7.6	7.8	8	8	8.2	8
Flavor of lean	8	7	7.4	6.4	8.2	7.6	7.2	7.4
Tenderness	7.8	8.2	7.4	5.6	8.6	7.2	7	7.4
Juiciness	7.4	5.2	6	6.4	7.4	6.4	6	7.6

Table 5. Summary of the quantitative analyses of the muscle segments of the normal and double-muscled steer.

	Normal steer			Double-muscled steer		
	R. eye	In. Rd.	O. Rd.	R. eye	In. Rd.	O. Rd.
ph	5.38	5.31	5.31	5.40	5.32	5.35
Protein	21.10	21.60	20.70	22.80	23.10	23.00
Fat	8.40	6.20	6.60	1.80	0.80	0.60
Moisture	69.55	71.17	69.12	73.67	74.42	75.27
Ash	1.02	1.05	1.01	1.07	1.16	1.14
Total	100.07	100.02	97.43	99.34	99.48	100.01

The muscle segments of the normal steer definitely had a higher fat content. The moisture and protein content of the muscle segments from the double-muscled steer were slightly higher; these differences were probably associated with the lower fat content of these muscle segments.

SUMMARY AND CONCLUSIONS

The double-muscled character consists of an enlargement of the skeletal muscles of the pelvic limbs and posterior loin region. The character is most pronounced in the thigh and rump muscles. Histological studies indicated that the enlargement of these muscles is due to a condition of hyperplasia.

The occurrence of the double-muscled character in the experimental herd indicated that it is transmitted as a single

autosomal recessive. The number of animals produced in the project was too small to prove this explanation of the mode of inheritance to be conclusive. The variations in the expression of the character are probably due to modifying factors.

Carcass studies indicated that the hindquarter, rump, and round of the double-muscled carcass are proportionally heavier than those of a normal carcass. The double-muscled carcasses lacked fat covering, intermuscle fat, and marbling. The meat from these carcasses had a coarse texture and lacked physical compactness. These characteristics are undesirable in respect to our present standards of grading meat and are considered to be unfavorable to meat storage.

Palatability studies indicated that the flavor of the lean of the cooked samples from a double-muscled steer's carcass was somewhat less desirable than that of the cooked samples from a normal steer's carcass. The outside round and inside round of the double-muscled steer's carcass received relatively low scores in respect to tenderness and juiciness, respectively.

Quantitative analyses of the muscle segments of the rounds and rib eyes indicated that the muscle segments of the normal steer's carcass had a much higher fat content than those of the double-muscled steer's carcass.

ACKNOWLEDGMENT

Acknowledgment is made to Dr. A. D. Weber, Dr. H. L. Ibsen, and Prof. David L. Mackintosh of the Department of Animal Husbandry; and to Dr. W. M. McLeod and Dr. L. M. Roderick of the Department of Veterinary Medicine for the information they furnished and the advice they gave throughout the investigation.

LITERATURE CITED

- (1) Kaiser, D.
Über die sog. doppellendigen Rinder. Landw. Jahrb.
17. 1898. Original not seen. Cited by (3).
- (2) Kronacher, C.
Allgemeine Tierzucht. Berlin: Verlagsbuchhandlung
Paul Parey. 1919.
- (3) Kronacher, C.
Genetik und Tierzüchtung. Berlin: Verlag von Gebrüder
Bornträger. 1934.
- (4) Hammond, John.
The inheritance of productivity in farm livestock. I.
Meat. Reprinted from the Empire Journal of Experi-
mental Agriculture. 3. 1935.
- (5) Loeffel, W. J.
Personal correspondence.
- (6) Malkus, B.
Clinical diagnostics of the internal diseases of farm
animals. Eleventh edition. Translated by J. R. Mohler
and Adolph Eichhorn. Chicago: Alexander Eger. 1936.
- (7) Möller, H.
Untersuchungen über die Vererbung der Hoarstarks bei
Fettsteib-Landschaf-Kreuzungen. In. - Diss. Halle a.
5. 1925. Original not seen. Cited by (3).
- (8) Pyndt.
Dobbeltlaredede Kalve. Manedskrift for Dyrläuger. 19.
1919. Original not seen. Cited by (3).
- (9) Shrode, R. R., and J. L. Lush.
The genetics of cattle. Advances in genetics. 1:209-
261. New York: Academic Press Inc. 1947.
- (10) Weber, A. D., and H. L. Ibsen.
The occurrence of the double-muscled character in pure-
bred beef cattle. Proc. Amer. Soc. Anim. Prod. 228-
232. 1934.

- (11) Wriedt, C.
Die Vererbung des doppelendercharakters bei Rindern.
Zeitschr. Ind. Abst. u. Vererbungslehre. 51:482-486.
1929.
- (12) Wright, S.
Coefficients of inbreeding and relationship. Amer.
Nat. 56:330-338. 1922.