

DISTRIBUTED STATE ESTIMATION
USING PHASOR MEASUREMENT UNITS (PMUs)
FOR A SYSTEM SNAPSHOT

By

WOLDU TUKU

B.S., University of Asmara Eritrea, 2003

A REPORT

submitted in partial fulfillment of the requirements for the degree

MASTER OF SCIENCE

Department of Electrical and Computer Engineering
College of Engineering

KANSAS STATE UNIVERSITY
Manhattan, Kansas

2012

Abstract

As the size of electric power systems are increasing, the techniques to protect, monitor and control them are becoming more sophisticated. Government, utilities and various organizations are striving to have a more reliable power grid. Various research projects are working to minimize risks on the grid. One of the goals of this research is to discuss a robust and accurate state estimation (SE) of the power grid. Utilities are encouraging teams to change the conventional way of state estimation to real time state estimation. Currently most of the utilities use traditional centralized SE algorithms for transmission systems.

Although the traditional methods have been enhanced with advancement in technologies, including PMUs, most of these advances have remained localized with individual utility state estimation. There is an opportunity to establish a coordinated SE approach integration using PMU data across a system, including multiple utilities and this is using Distributed State Estimation (DSE). This coordination will minimize cascading effects on the power system. DSE could be one of the best options to minimize the required communication time and to provide accurate data to the operators. This project will introduce DSE techniques with the help of PMU data for a system snapshot. The proposed DSE algorithm will split the traditional central state estimation into multiple local state estimations and show how to reduce calculation time compared with centralized state estimation. Additionally these techniques can be implemented in micro-grid or islanded system.

Table of Contents

	Page
List of Figures.....	V
List of Tables.....	VII
Acknowledgements.....	VIII
CHAPTER 1- INTRODUCTION.....	1
1.1 Modern Electric Power System.....	1
1.2 Concepts of State Estimation.....	5
1.3 General Concept and Background of PMUs.....	6
1.4 Motivation and Objective of the research.....	7
1.5 Project organization.....	8
CHAPTER 2 - TRADITIONAL STATEESTIMATION.....	9
2.1 Traditional State Estimation techniques.....	9
2.2. Model Design.....	9
2.2.1. Transmission Line Component Modeling.....	10
2.2.2. Transformer Modeling.....	10
2.2.3. Shunt Capacitor and Reactor Modeling.....	11
2.3 The Bus-Admittance Matrix.....	12
2.4 Maximum Likelihood Estimation.....	12
2.5 Weighted Least Squares State Estimation Algorithm	14
2.6. Power System Measurement Functions.....	16
2.7. Jacobian of Measurement.....	18
CHAPTER 3 - PHASOR MEASUREMENT ASSISTED STATE ESTIMATION	21
3.1 Inclusion of PMU Data in Traditional State Estimation.....	22
3.1.1 Integration of Phasor and Traditional measurements.....	23
3.1.2 Inclusion of Phasor measurements into post processin Technique.....	26
3.3 PMU Data in linearizing State Estimation.....	27

CHAPTER 4 - DISTRIBUTED SE WITH PHASOR MEASUREMENT UNIT	34
4.1 Introduction.....	34
4.2 DSE Algorithm and Algorithm and Scheme.....	36
4.3 Proposed DES Summary.....	41
4.4 SUMMARY	53
CHAPTER 5 – RECOMMENDATIONS AND NEXT STEPS.....	55
REFERENCE.....	62

List of Figures

Figure 1.1 RTO's in the United States.....	2
Figure 1.2 2003 Blackout Operators.....	3
Figure 1.3 Block diagram of PMU.....	7
Figure 2.1 Two-port Π -Model.....	10
Figure 2.2 RTO's in the United States.....	10
Figure 2.3 Tap changing transformer.....	11
Figure 2.4 Shunt capacitor and reactor.....	11
Figure 2.5 Flow chart for the WLS SE algorithm.....	17
Figure 3.1 PMU connection on a substation.....	23
Figure 3.2 Simple PMU measurement model.....	24
Figure 3.3 Block diagram of CSE Non-linear iterative method.....	25
Figure 3.4 Post-processing linear method.....	26
Figure 3.5 Two-port Π -Model of Transmission line.....	29
Figure 3.6 Simple Two bus system with PMU measurements.....	31
Figure 3.7 DSE non-linear iterative method.....	33
Figure 4.1 Hierarchical SE Diagram.....	35
Figure 4.2 Power system with three subsystems.....	37
Figure 4.3 Proposed DSE.....	40
Figure 4.4 PMU placement algorithm.....	41
Figure 4.5 Decomposition of the IEEE 118 bus.....	42
Figure 4.6 Voltage magnitude comparison of sub-system 3 DSE with PMU on bus 110 and 81.....	43
Figure 4.7 Phase angle comparison of sub-system 3 DSE with PMU on bus 110 and 81.....	44
Figure 4.8 Aggregate bus set on the lower boundary of subsystem 1 & 2 with weak connection.....	45
Figure 4.9 Aggregate level bus set on the upper boundary of subsystem 1 & 2 with weak connection.....	46
Figure 4.10 Coordination level bus set on the lower boundary of subsystem 2 & 3 with weak connection.....	46

Figure 4.11 Voltage magnitude comparison of DSE solution and integrated SE slution.....	47
Figure 4.12 Phase angle comparison of DSE solution and integrated SE solution.....	49
Figure 4.13 Flow chart of centralized state estimation.....	50
Figure 4.14 Flow chart of Distributed Centralized State Estimation.....	51
Figure 5.1 Updated map of PME distribution in North American Power Grid.....	56
Figure 5.2 Map of Kansas proposed and existing wind project.....	58
Figure 5.3 Data comparison between PMU and SCADA for Oklahoma Gas and electric system distribution data	60

List of Tables

Table 4.1	PMU allocation.....	42
Table 4.2	118 Bus test-bed bus branch connectivity data.....	44
Table 4.3	Comparison of Integrated and DSE solutions.....	47
Table 4.4	IEEE 118 bus test result computation time for traditional SE and DSE.....	52
Table 4.5	IEEE 118 bus test result of accuracy for traditional SE and DSE.....	52
Table 5.1	Kansas wind farms.....	58

ACKNOWLEDGMENTS

First and foremost, I would like to express my deepest gratitude to Dr. Schulz for her guidance and encouragement. She has been a source of inspiration in the last three semesters in Kansas State University.

I would like to thank my committee members, Dr. Ruth Miller and Dr. Shelli Starrett, for their help. I would also like to acknowledge my professors at Kansas State University from whom I have learned so much.

Finally, I would like to express my love and gratitude to my parents for their endless support and encouragement.

CHAPTER 1

INTRODUCTION

1.1 Modern Electric Power System

The electric power system is very important in our day-to-day activities. Due to its role and complexity it is one of the critical infrastructure systems. It is composed of generation, transmission, and distribution systems as well as loads. Power flows from generation plant to end users via the grid, so the power system needs to be upgraded every time new technique or device evolves. This helps provide updated and accurate information to power personnel to provide reliable power and satisfy the needs of consumers. That is why system operators plan, monitor, analyze and control the operation of the power grid by using special tools such as load forecasting, state estimation, congestion management, security assessment and others.

As the power system size increases, some challenges start to appear due to the increase in demand on the customer's side and the need of additional generators and transmission lines. That is why deregulation was required. Introduction of deregulation was supposed to bring the following advantages improvement of services, increase in efficiency, alleviation of prices and advancement in technology due to completion among utilities and manufacturers. With the start of deregulation, the way the power system shares information has changed. The utilities are reluctant to share information with other utilities, which has created a lack of obtaining system wide coordination. The lack of proper system wide coordination doesn't help in minimizing cascading of fault in the system. So to face these challenges, utilities should work based on horizontal integration which includes multi-utilities working together to make the power system more reliable. Nowadays many companies are involved, one company controls the transmission system and others may own the generation and distribution system. The challenge with deregulation is that, close monitoring of the power system is more difficult; accordingly to achieve more reliable and secure power system will be difficult.

Even though perfection is difficult, studying the whole grid allows for the power system operators to work hard to make sure power is constantly available over the whole power system. There are so many activities in progress to make it reliable.

Several independent system operators (ISO) were developed in the 1990s to control system reliability by supervising different sections. The Federal Energy Regulatory Commission (FERC) issued order no. 2000, which orders all transmission systems to be a member of a Regional Transmission Organization (RTO) [1]. A quick detection and response to contingencies helps in optimizing operation efficiency and reliability of the power system. Some of the RTO's in the USA are shown in Fig1.1 [2].

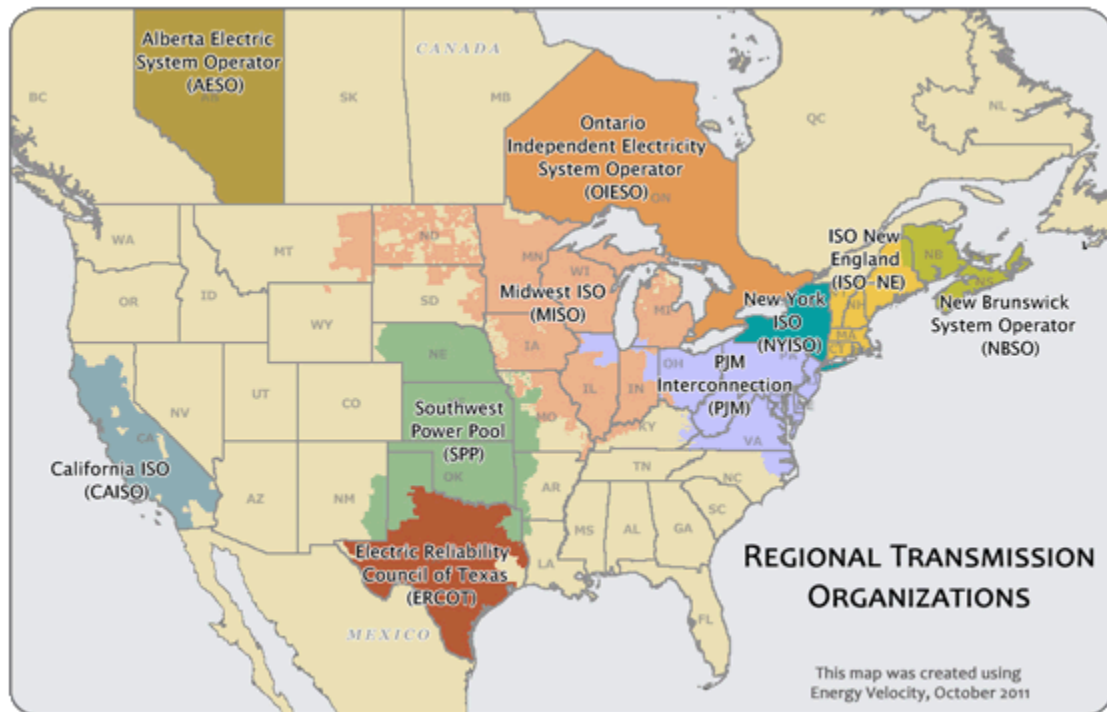

Fig1.1 RTO's in the United States [2]

In the United States, there are many utilities which have not joined ISOs/RTOs for different reasons. As seen in Fig1.1, some states in the west, northwest, and some parts in the southwest have not joined ISO/RTO. The utilities on these areas are still working as separated and vertically integrated utilities, meaning that all the responsibilities, to generate transport and distribute the power reliably is done individually. With the involvement of individual RTO sponsors, utilities can arrive at a common understanding to create a regional RTO. A plan that was proposed to FERC mentions “properly formed RTO should include all transmission owners in (the southeast) region, including municipals, cooperatives, Federal Power Marketing

Agencies (PMAs), Tennessee Valley Authority and other state and local entities” [3]. The plan clearly underscores that the RTO “will be responsible for directing the operations of the transmission system, monitoring and controlling real and reactive power flows and voltages levels, and scheduling and directing the operation of reactive resources” [3]. Controlling and monitoring a small area cannot help when emergency happens, so a wide area monitoring is very important in controlling a wide scale system network. Due to this reason FERC supports the reliability assurance to be handled based on a wide scale which results in a better close monitoring of wide area and control in system reliability and system security. This decision was justified by the blackout that took place in August 14, 2003 in the North American power system [4].

The final report of the U.S.-Canada Power System Outage Task Force showed that even though RTO’s are increasing in size, there are more things to improve. The power system is an interconnected network which needs not only monitoring of internal buses but also needs to study the boundary buses and the part of the internal buses that impact the boundary buses.



Fig 1.2 2003 Blackout Operators [4]

In Fig1.2 above the area covered by the rectangle is where the blackout has happened. It was due to miscommunication between operators and lack of exchange of

information among utilities. If it had been controlled by cooperation between the utilities, the problems could have been minimized or may have been avoided. The task force [4] recommends the increase of size and responsibilities of regional reliability councils and the development of mutual information sharing to make the power system more reliable and secure.

The system operators should also focus on the power flow across the tie lines, boundary buses and the sensitive internal buses. To schedule a power transaction in a large network, the state of the operating system snapshot is important in providing awareness of the system. As we mentioned earlier deregulation brings competition among energy suppliers, as it allows customers to choose their electricity supplier. Due to this fact the utilities started to withhold information and not share it with neighboring utilities. Each utility has its own state estimator that performs state situation awareness of their system. But lack of information exchange about the whole grid places challenges on the reliability and security of the overall power system. This causes problems in accuracy of analysis and the efficiency of the modern power system. These problems could be solved by getting a snapshot of the sophisticated system [4].

One of the key tools to obtain the required data to study the grid and get a system snapshot is state estimation. State Estimation (SE) is the process of allocating a value to an unknown system state variable based on known observations obtained from the system [5]. To complete the wide area state estimation of the power grid, information must be gathered from dispersed sensors installed across the power system of many smaller and often competing companies. Various utilities use different techniques to determine their system state estimation. The widely used state estimator data source is Supervisory Control and Data Acquisition system (SCADA). Although it has supervisory task to accomplish, it does not have full control of the system. It is still a widely used technique to determine steady state monitoring of the power system and to gather measurement for SE analysis.

The current state estimation techniques in power systems are mainly applicable for centralized power system. On the other hand the physical power system networks are inter-connected with each other through tie lines. For example the Southwest

Power Pool lies within the eastern interconnection, in the central southern United States, it serves the states of Kansas and Oklahoma, and portions of New Mexico, Texas, Arkansas, Louisiana, Missouri and Nebraska. As it is mentioned in [4], if the utilities are not able to share information, monitoring the wide area network is difficult. So, utility based state estimation is not adequate to make system wide analysis and monitoring. To avoid risks out of the power system network, sharing of information among the utilities connected to the grid is important to maintaining situational awareness of the system. In this project I will discuss distributed state estimation techniques with the help of phasor measurement units (PMUs) to minimize computational time and to enhance the accuracy of data input into the state estimator. The following sections will present the history of state estimation in power systems and the PMU backgrounds.

1.2 Concepts of State Estimation

The power system state is represented by a number of complex voltages at each node in the network [5]. In general terms it can be defined as the least set of variables that should be known to determine the full operating conditions of the system. In the power system there are known parameters such as line impedance and measured values such as voltage magnitude. With the help of these data and the existing network topology, it is possible to calculate the values of real power flow, reactive power flow, real power injection and reactive power injection. As the size and complexity of the power system grows, it becomes very important for system operators to know how the system is behaving [7]. In the past, prior to the invention of PMU, the calculation of the operating point of a power system was based on measurement collected by the SCADA system [6]. This kind of technique can sometimes fail to provide accurate data; hence, it results in the divergence of load flow equations.

As we can observe from historical data, the scale of a blackout could be avoided or reduced if the system operators had better and more up-to-date information regarding their systems operating condition [4]. A familiar blackout example is the Northeast Blackout of 1965; it took 12 hours to restore electricity to about 30 million people. This has caused engineers and researchers to take major steps in modifying the way control centers perform and to create a more reliable tool for operators to use [6].

To address the problem, a technique which was proposed by Fred Schweppe in the 1960's [8, 9, and 10] was adopted. The technique provides data like bus voltage magnitudes, feeder's current magnitudes, and real and reactive power flows. It provides redundant measurements, which help in making accurate decision of states. A non-linear model was used to process the measurements and multiple iterations were needed to give the right solution for the state of the system.

Determination of the state variable takes several iterations and measurement collections in the power system, which is time consuming. Moreover, a delay in communication results in increased sending times [6]. Due to these delays a cascading fault can occur; however, in the last several decades, state estimation has advanced into a higher level [7]. Power system state estimation has changed its effectiveness and functionality in the power system and the new technologies have made it a very valuable technique. The power system operators are getting close to the stage of controlling the power on a real time basis with the help of phasor technology.

1.3 General Concept and Background of PMUs

Phasor Measurement Units (PMUs) are intelligent electronic devices (IED) of phasor technology which provide time-synchronized data (typically more than 60 samples/second [11]). It provides synchronized phasor measurements from geographically dispersed power systems with the help of global positioning system (GPS) [11]. The basic block diagram of synchrophasor measurement is shown in Fig 1.3 below [12].

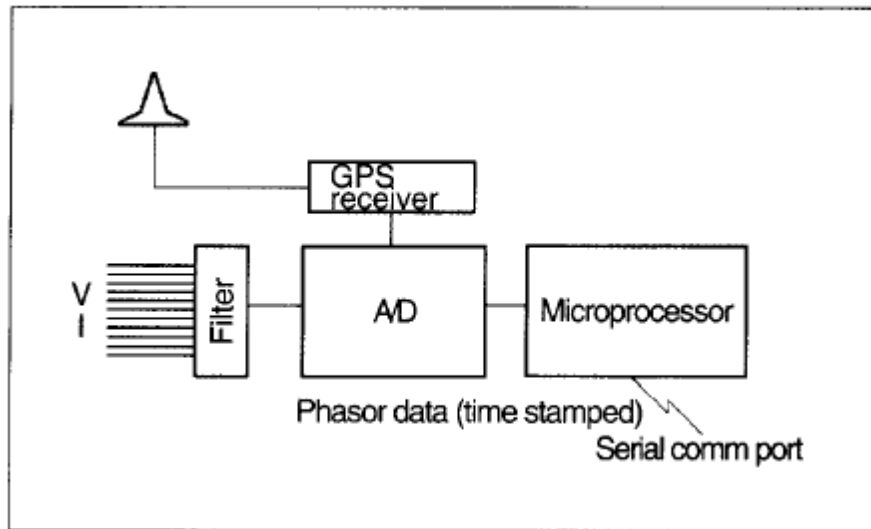

Fig 1.3 Block diagram of PMU [12]

The time-synchronized data enables PMU to monitor wide area network, real time dynamics of the power system operation and provides improvements in state estimation, protection and control of the bulk power system. The price of PMU decreased significantly over the last two decades due to advances in computer and GPS technology [6]. Still the sensors are expensive and the cost of installation due to security and communication has increased. Although it's expensive, investing in PMU's is worthwhile taking into consideration the advantages it would bring to the system such as lowering the computational and system wide monitoring time[6]. At the top of these advantages, if PMUs are installed in all the buses of the power system that need to be measured then we can get a linear system which helps to determine the state of a system without making iterations [40]. These applications of PMUs enable to control and secure the reliability of a wide area network.

1.4 Motivation and Objective of the Research

The major objective of this research project is to outline what can be done in the field of state estimation specially Distributed State Estimation (DSE) using PMU Data. The end goal of the project is to propose a distributed state estimation with the help of PMUs for a system snapshot and then summarize its advantages over traditional state

estimation. Currently there are many research efforts to reach optimum state estimation using phasor measurement units.

First, the research project discusses the background information on the topic of state estimation and PMUs. Then it is, followed by the presentation of the traditional state estimation and the system state estimation with and without PMU. It continues with the discussion of distributed state estimation utilizing phasor measurements to obtain system snapshot, and finally conclude by providing a summary of the report.

1.5 Project organization

This report is organized in the following way:

Chapter 1: presents the motivation and objectives of the research by discussing background and current information regarding the power system. It details the use of wide area snapshot on power system reliability optimization. It continues by investigating the story of PMU development and state estimation as it has evolved over the decades and will finish by outlining the contents of each chapter.

Chapter 2: presents the mathematical formulation of the algorithm employed by traditional state estimation techniques. It explores system component modeling, maximum likelihood estimation, weighted least squares (WLS) estimation (including the WLS algorithm and matrix formulation), and a brief discussion concerning statistical robustness of the weighted least squares estimator.

Chapter 3: will discuss the application of PMUs in state estimation. It will present some reasons for the paradigm change from traditional state estimation to linear methods using the PMU data.

Chapter 4: will represent the body of the project research and will show the benefits of distributed state estimation over traditional state estimation. It will include the use of phasor measurement units to optimize the distributed state estimation, and cover how DSE can be applied to provide a bulk power system snapshot. And finally a summary of numerical test results and conclusion are provided.

Chapter 5: will present recommendations and its possible application in the states of Kansas and Nebraska power system.

CHAPTER-2

Traditional State Estimation

State estimation is the process of computing a state variable of a system from known measurements of a system. In power systems, state estimation refers to the collection of enough measurements from the buses around the power system and computing a state vector of the voltage at each observed bus. Although no breakthroughs in the fundamental concept of state estimation have occurred, the state estimator analysis has improved a lot over the past few years. The first step is to collect the non-linear measurements and then perform iteration to evaluate the close value of the state variable. This chapter presents the mathematical basis for traditional state estimation techniques.

2.1 Traditional State Estimation Techniques

The power system state parameters under consideration are real power flow, reactive power flow, current injections, voltages, resistance, reactance, and shunt susceptance [7]. Field measurements need to be sent periodically into the control center over a SCADA network in traditional state estimation. The real system and the model should be closely related to each other. To achieve this, careful construction of transmission line parameter and physical system model is required. The rest of this chapter will present how to construct the system model in applying traditional state estimation.

2.2. Model Design

In power flow analysis the general parameters of importance are transmission line, transformers, shunt capacitors or reactors. Since state estimation calculation in the power system is the same into the power flow calculation, the parameters used in power flow are also used in state estimation calculations [13]. Knowledge of the overall topological structure of the power system network is essential in analyzing state estimation of the wide area network.

2.2.1. Transmission Line Component Modeling

The two-port π -model, equivalent of the transmission line, is used for analysis of state estimation purposes. The model, in Fig2.1, has four parameters and is widely used in power flow calculation and most state estimation techniques.

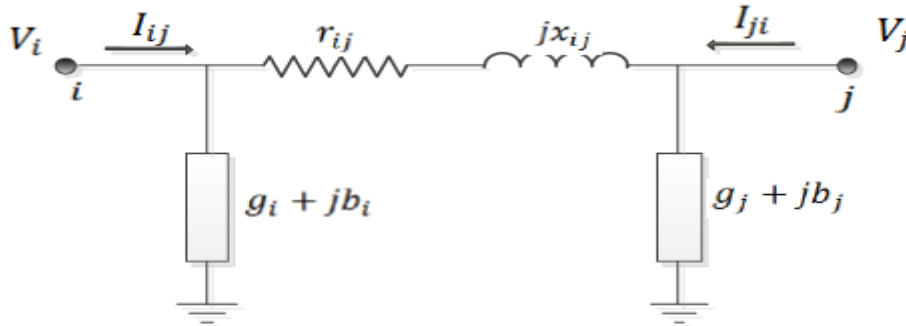

Fig 2.1 Two-port π -model

In this two-port π -model, the losses in the transmission line and the energy stored around the conductors as a magnetic field and line charging are represented by resistance, inductor models and shunt impedance respectively [14]. All the models parameters are in per unit.

2.2.2. Transformer Modeling

Fig 2.2 shows a transformer branch model.

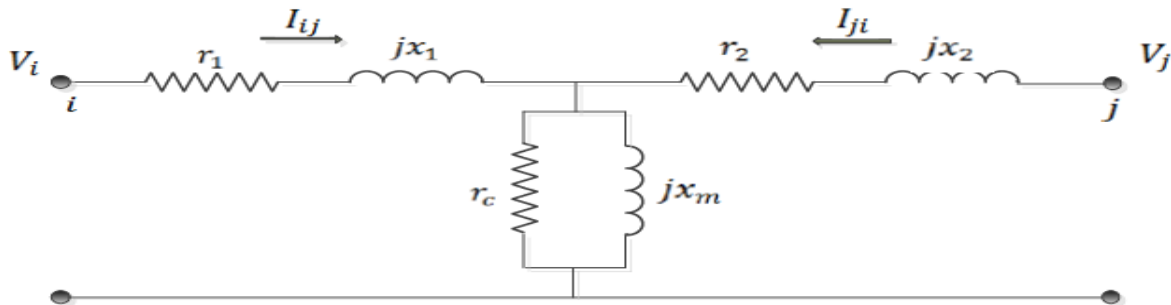

Fig 2.2 Transformer Model

As can be seen the transformer has series impedance and shunt impedance. The real and imaginary parts of the shut impedance are due to eddy current losses and hysteresis losses

respectively. The inductance is produced from the way the conductors are arranged in a coil and the resistance represents the real losses in the coils. The transmission line and transformer are connected through at their ends with other parts of the network. Tap changing transformer, Fig 2.3., is modeled using series impedance in series with the transformer model [7].

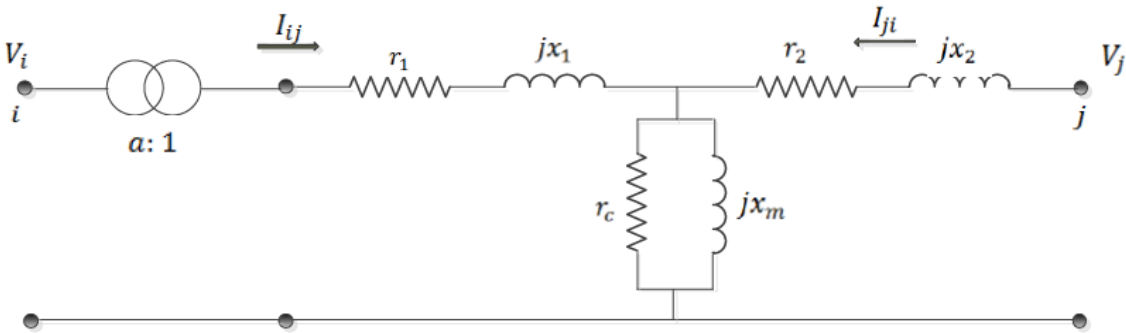

Fig 2.3 Tap changing Transformer.

2.2.3. Shunt Capacitor and Reactor Modeling

Modeling of other parameters is crucial to achieve a reliable and controllable power system. These parameters are shunt capacitors and reactors. They are used as reactive power backups and voltage control. They are installed at specific buses which significantly impact the power flow [7].

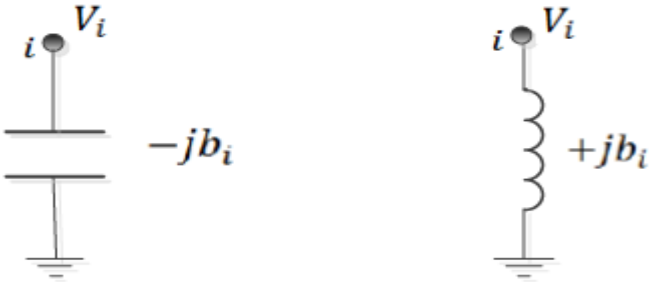

Fig 2.4 Shunt capacitor and reactor

2.3 The Bus-Admittance Matrix

To build the network model, transmission line series and shunt impedance, transformer impedance, and shunt capacitors and reactors should be defined. Then they can be combined together to construct a model of the system. The model is usually named as the admittance matrix or the Y-Bus of the power system. Traditionally, a Y-Bus matrix is used because of its advantage over an impedance matrix. The Y-Bus takes the following form:

$$I = \begin{bmatrix} i_1 \\ i_2 \\ \vdots \\ i_n \end{bmatrix} = \begin{bmatrix} Y_{11} & Y_{12} & \cdots & Y_{1N} \\ Y_{21} & Y_{22} & \cdots & Y_{2N} \\ \vdots & \vdots & \ddots & \vdots \\ Y_{N1} & Y_{N2} & \cdots & Y_{NN} \end{bmatrix} \begin{bmatrix} v_1 \\ v_2 \\ \vdots \\ v_N \end{bmatrix} = Y * V \quad (2.1)$$

To construct the admittance matrix usually Kirchoff's current law is used. The ii^{th} element of the admittance matrix is the sum of the admittances of all of the lines connected to bus i and the ij^{th} element of the admittance matrix is the negative of the admittance between bus i and bus j [7].

2.4 Maximum Likelihood Estimation (MLE)

One of the techniques used in state estimation of power system is maximum likelihood estimation. It is a statistical state estimation method which first requires deriving the likelihood function of the measurement vector. The function is obtained by multiplying the probability density functions of each measurement and the maximum likelihood estimation aims to estimate the unknown parameters of each of the measurements' probability density functions through an optimization [7]. Likelihood is a relative measure of certainty and the probability density function for power system measurement error is a Gaussian probability density function. A probability density function (PDF) of a continuous random variable is a function that describes the relative likelihood for this random variable to occur at a given point in the observation space.

$$f(z) = \frac{1}{\sqrt{2\pi}\sigma} e^{-\frac{1}{2}\left(\frac{z-\mu}{\sigma}\right)^2} \quad (2.3)$$

Where, z is the random variable of the probability density function, μ is the expected value, and σ is the standard deviation. PDF function would yield the probability of a measurement being a particular value, z . Therefore, the probability of measuring a particular set of ‘ m ’ measurements each with the same probability density function is the product of each of the measurements PDF.

$$f_m(z) = \prod_{i=1}^m f(z_i) \quad (2.3)$$

Where, z_i is the i^{th} measurement and

$$[z] = \begin{bmatrix} z_1 \\ z_2 \\ z_3 \\ \vdots \\ z_m \end{bmatrix} \quad (2.5)$$

The aim of MLS estimation is to maximize this function to determine the unknown parameters of the PDF of each of the measurements and it is achieved either by maximizing the algorithm of the likelihood function, ‘ $f_m(z)$ ’, or minimizing the weighted sum of the residuals [7]. This can be written as

$$\text{minimize } \sum_{i=1}^m w_{ii} r_i^2 \quad (2.6)$$

$$\text{subject to } z_i = h_i(x) + r_i$$

Where

r_i =residual of measurement i

w_{ii} = weighted factor the residual

We know that MLE is a better state estimation technique, but it is difficult to get the PDF of a measurement in the real world. In power system we use the Gaussian distribution PDF. When we use the Gaussian PDF this technique is the same with the Weighted Least Square State Estimation (WLS) technique and because of the least computation WLS is widely used to get state estimation of any state variable. The solution to the above problem is referred to as the weighted least squares estimator for x .

2.5 Weighted Least Squares State Estimation Algorithm

As mentioned in the earlier sections power system state estimators use a set of redundant measurements taken from the power system to determine the closest system state for the given information and assumptions. These measurements help to get the best estimation through multiple iterations. The state estimator becomes a weighted least squares estimator with the inclusion of the measurement error covariance matrix. The measurement error covariance is used to weight the accuracy of each of the measurements. The mathematical formulation for the WLS estimator is expressed in several texts and in [6, 7, and 8]. Let's assume a measurement vector denoted by z containing 'm' number of measurements and a state vector denoted by 'x' containing 'n' number of state variables.

$$[z] = \begin{bmatrix} z_1 \\ z_2 \\ z_3 \\ \vdots \\ z_m \end{bmatrix} \quad [x] = \begin{bmatrix} x_1 \\ x_2 \\ x_3 \\ \vdots \\ x_n \end{bmatrix} \quad (2.7)$$

Usually, traditional state estimation techniques use non-linear functions of the system state vector measurements. The vector forms of these functions are

$$[h(x)] = \begin{bmatrix} h_1(x_1 \ x_2 \ x_3 \ \dots \ x_n) \\ h_2(x_1 \ x_2 \ x_3 \ \dots \ x_n) \\ h_3(x_1 \ x_2 \ x_3 \ \dots \ x_n) \\ \vdots \\ h_m(x_1 \ x_2 \ x_3 \ \dots \ x_n) \end{bmatrix} \quad (2.8)$$

Where $h(x)$ is a measurement function. Each measurement has its own unknown error ' e '. The measurement errors, shown in Eq. (2.9) are assumed to be independent of one another and have an expected value of zero.

$$[e] = \begin{bmatrix} e_1 \\ e_2 \\ e_3 \\ \vdots \\ e_m \end{bmatrix} \quad (2.9)$$

The state equation using non-linear functions can be written

$$[z] = [h(x)] + [e] \quad (2.9)$$

From the previous section, the solution to the state estimation problem can be formulated as a minimization of following objective function.

$$J(x) = \sum_{i=1}^m (z_i - h_i(x))^2 / R_{ii} \quad (2.11)$$

Where 'R' is the covariance matrix of the measurement errors and is diagonal in structure. This represents the summation of the squares of the measurement residuals weighted by their respective measurement error covariance. This can be redefined as-

$$J(x) = [z - h(x)]^T [R]^{-1} [z - h(x)] \quad (2.12)$$

To find the minimization of this objective function the derivative should be set to zero. The derivative of the objective function is represented by g(x).

$$g(x) = \frac{\partial J(x)}{\partial x} = - \left[\frac{\partial h(x)}{\partial x} \right]^T [R]^{-1} [z - h(x)] = 0 \quad (2.13)$$

Let

$$[H(x)] = \left[\frac{\partial h(x)}{\partial x} \right] \quad (2.14)$$

Where H(x), is called the measurement Jacobian matrix. Ignoring the higher order terms of the Taylor series expansion of the derivative of the objective functions yields an iterative solution known as the Gauss-Newton method.

$$x^{k+1} = x^k - [G(x^k)]^{-1} \cdot g(x^k)$$

$$G(x^k) = \frac{\partial g(x^k)}{\partial x} = H^T(x^k) \cdot R^{-1} \cdot H(x^k)$$

$$g(x^k) = -H^T(x^k) \cdot R^{-1} \cdot (z - h(x^k))$$

$$x^{k+1} = x^k - [G(x^k)]^{-1} \cdot g(x^k)$$

$$\Delta x^{k+1} = x^{k+1} - x^k$$

$$x^{k+1} = x^k + \left[[H(x^k)]^T [R]^{-1} [H(x^k)] \right]^{-1} \left[[H(x^k)]^T [R]^{-1} [z - h(x^k)] \right]$$

$$[G(x^k)] \Delta x^{k+1} = H^T(x^k) \cdot R^{-1} \cdot [z - h(x^k)] = H^T(x^k) \cdot R^{-1} \cdot \Delta z^k \quad (2.15)$$

From the defined system models such as branch parameters, network topology and measurement locations, the measurement function and measurement Jacobian can be built. We know that the only information required to iteratively solve this optimization is the covariance matrix of measurement errors, R , and the measurement function, $h(x)$. The error covariance matrix should also be constructed. In the first iteration of the optimization the measurement function and the measurement Jacobian should be evaluated at flat start. The reason of these values is that before we start any calculation slack bus with these values should be selected and all the other buses should be referenced to that bus. These values are the ideal values in power system power flow calculation. In combination with the measurements and results from the initial iterations, the next iteration of the state vector can be calculated until the required solution is obtained; finally the state of the system is determined. The flow chart of the iterative algorithm for WLS state estimation is shown in Fig 2.6. Initially set the iteration counter $k=0$, define the convergence tolerance e , and the iteration limit k_{limit} values. If $k > k_{limit}$ then- terminate the iterations. Calculate the measurement function $h(x^k)$, the measurement Jacobian $H(x^k)$, and gain matrix $G(x^k) = H^T(x^k)R^{-1}H(x^k)$, then solve Δx^k from Eq. 2.15.. Then if $|\nabla x^k| > e$, then compute till $k < k_{lim}$ else, stop. Algorithm is converged to the required solution.

2.6. Power System Measurement Functions

The measurements in the power system include real and reactive power bus injections and flows, line current flow magnitude and bus voltage magnitudes. The two-port π -model is used to construct equations that relate the state vector measurement. The real and reactive injection powers to bus i are P_i and Q_i , and are computed as follows:

$$P_i = v_i \sum_{j=1}^N v_j (G_{ij} \cos \theta_{ij} + B_{ij} \sin \theta_{ij}) \quad (2.16)$$

$$Q_i = v_i \sum_{j=1}^N v_j (G_{ij} \sin \theta_{ij} - B_{ij} \cos \theta_{ij}) \quad (2.17)$$

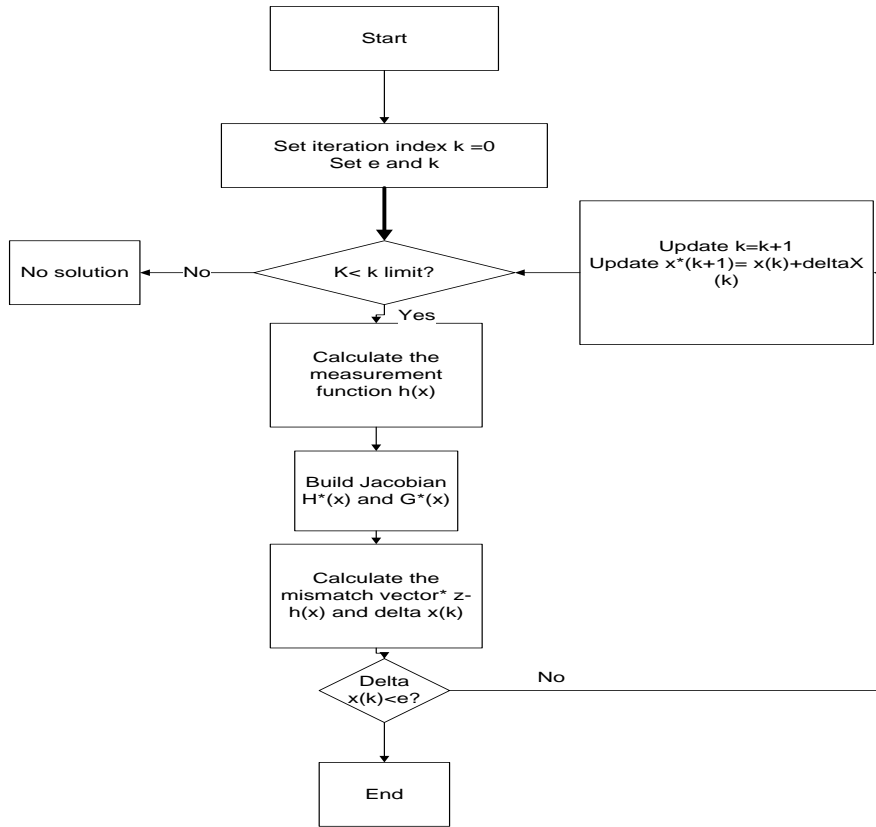

Fig 2.5 Flow chart for the WLS State estimation algorithm

The conductance and susceptance in the equations follows the notation of the two-port π -model. Similarly the real and reactive power flows between bus i and bus j are described as

$$P_{ij} = v_i^2(g_i + g_{ij}) - v_i v_j (g_{ij} \cos \theta_{ij} + b_{ij} \sin \theta_{ij}) \quad (2.18)$$

$$Q_{ij} = -v_i^2(b_i + b_{ij}) - v_i v_j (g_{ij} \sin \theta_{ij} - b_{ij} \cos \theta_{ij}) \quad (2.19)$$

Additionally, the line current magnitude from bus i to bus j can be expressed as the following. S_{ij} is the complex power.

$$I_{ij} = \sqrt{(P_{ij}^2 + Q_{ij}^2)} / v_i = S_{ij} / v_i \quad (2.20)$$

2.7. Jacobian of Measurements

The measurement Jacobian is the derivative of the measurement function with respect to the state vector. The structure is seen in (2.21). The order of the rows and columns of the measurement function corresponds to the order of the measurement vector and the state vector respectively. Once constructed, the elements of the Jacobian matrix are non-linear functions of the state variable and are re-evaluated for each iteration of the estimation solution. The Jacobian measurement structure will be as follows [7].

$$[H] = \begin{bmatrix} \frac{\partial P_{inj}}{\partial \theta} & \frac{\partial P_{inj}}{\partial v} \\ \frac{\partial P_{flow}}{\partial \theta} & \frac{\partial P_{flow}}{\partial v} \\ \frac{\partial Q_{inj}}{\partial \theta} & \frac{\partial Q_{inj}}{\partial v} \\ \frac{\partial Q_{flow}}{\partial \theta} & \frac{\partial Q_{flow}}{\partial v} \\ \frac{\partial I_{mag}}{\partial \theta} & \frac{\partial I_{mag}}{\partial v} \\ 0 & \frac{\partial V_{mag}}{\partial v} \end{bmatrix} \quad (2.21)$$

The elements of the Jacobian matrix are computed as follows:

a.) Elements of Real power injection measurements.

$$\frac{\partial P_i}{\partial \theta_i} = \sum_{j=1}^N v_i v_j (-G_{ij} \sin \theta_{ij} + B_{ij} \cos \theta_{ij}) - v_i^2 B_{ii} \quad (2.22)$$

$$\frac{\partial P_j}{\partial \theta_j} = v_i v_j (G_{ij} \sin \theta_{ij} - B_{ij} \cos \theta_{ij}) \quad (2.23)$$

$$\frac{\partial P_i}{\partial v_i} = \sum_{j=1}^N v_j (G_{ij} \sin \theta_{ij} + B_{ij} \cos \theta_{ij}) - v_i G_{ii} \quad (2.24)$$

$$\frac{\partial P_i}{\partial v_j} = v_j (G_{ij} \sin \theta_{ij} + B_{ij} \cos \theta_{ij}) \quad (2.25)$$

b.) Elements of Reactive power injection measurements.

$$\frac{\partial Q_i}{\partial \theta_i} = \sum_{j=1}^N v_i v_j (G_{ij} \cos \theta_{ij} + B_{ij} \sin \theta_{ij}) - v_i^2 G_{ii} \quad (2.26)$$

$$\frac{\partial Q_j}{\partial \theta_j} = -v_i v_j (G_{ij} \cos \theta_{ij} + B_{ij} \sin \theta_{ij}) \quad (2.27)$$

$$\frac{\partial Q_i}{\partial v_i} = \sum_{j=1}^N v_j (G_{ij} \sin \theta_{ij} - B_{ij} \cos \theta_{ij}) - v_i B_{ii} \quad (2.28)$$

$$\frac{\partial Q_i}{\partial \theta_j} = v_i (G_{ij} \sin \theta_{ij} + B_{ij} \cos \theta_{ij}) \quad (2.29)$$

c). Elements of Real power flow measurements.

$$\frac{\partial P_{ij}}{\partial \theta_i} = v_i v_j (g_{ij} \sin \theta_{ij} - b_{ij} \cos \theta_{ij}) \quad (2.30)$$

$$\frac{\partial P_{ij}}{\partial \theta_j} = -v_i v_j (g_{ij} \sin \theta_{ij} - b_{ij} \cos \theta_{ij}) \quad (2.31)$$

$$\frac{\partial P_{ij}}{\partial v_i} = -v_j (g_{ij} \cos \theta_{ij} + b_{ij} \sin \theta_{ij}) + 2(g_{ij} + g_i) v_i \quad (2.32)$$

$$\frac{\partial P_{ij}}{\partial v_j} = -v_i (g_{ij} \cos \theta_{ij} + b_{ij} \sin \theta_{ij}) \quad (2.33)$$

d). Elements of Reactive power flow measurements.

$$\frac{\partial Q_{ij}}{\partial \theta_i} = -v_i v_j (g_{ij} \cos \theta_{ij} - b_{ij} \sin \theta_{ij}) \quad (2.34)$$

$$\frac{\partial Q_{ij}}{\partial \theta_j} = v_i v_j (g_{ij} \cos \theta_{ij} + b_{ij} \sin \theta_{ij}) \quad (2.35)$$

$$\frac{\partial Q_{ij}}{\partial v_i} = -v_j (g_{ij} \sin \theta_{ij} - b_{ij} \cos \theta_{ij}) - 2(b_{ij} + b_i) v_i \quad (2.36)$$

$$\frac{\partial Q_{ij}}{\partial v_j} = -v_i (g_{ij} \sin \theta_{ij} + b_{ij} \cos \theta_{ij}) \quad (2.37)$$

e). Elements of Voltage magnitude measurements. Note that the voltage magnitude is not a function of voltage magnitude or angle at any bus besides its own.

$$\frac{\partial v_i}{\partial v_i} = 1, \frac{\partial v_i}{\partial v_j} = 0, \frac{\partial v_i}{\partial \theta_i} = 0, \frac{\partial v_i}{\partial \theta_j} = 0 \quad (2.38, 2.39, 2.40, 2.41 \text{ respectively})$$

f). Elements of Current magnitude measurements. For these equations the shunt branch has been ignored.

$$\frac{\partial I_{ij}}{\partial \theta_i} = \frac{g_{ij}^2 + b_{ij}^2}{I_{ij}} v_i v_j \sin \theta_{ij} \quad (2.42)$$

$$\frac{\partial I_{ij}}{\partial \theta_j} = -\frac{g_{ij}^2 + b_{ij}^2}{I_{ij}} v_i v_j \sin \theta_{ij} \quad (2.43)$$

$$\frac{\partial I_{ij}}{\partial v_i} = \frac{g_{ij}^2 + b_{ij}^2}{I_{ij}} (v_{ij} + v_j \cos \theta_{ij}) \quad (2.44)$$

$$\frac{\partial I_{ij}}{\partial v_j} = \frac{g_{ij}^2 + b_{ij}^2}{I_{ij}} (v_i \cos \theta_{ij} - v_j) \quad (2.45)$$

The H matrix has rows at each measurement and columns at each variable. Most of the time, the H matrix contains more zero components and that's why sparse matrix technique is used in constructing it. This chapter presented traditional state estimation techniques and the formulation of the weighted least squares solution of a non-linear state estimation algorithm. Regardless of its errors, WLS is the most widely used technique in electric utilities and has proven itself over several years. However, PMUs will provide a more accurate and time sensitive data, which helps in minimizing computational time in the state estimation technique; therefore the inclusion of PMU data will provide additional advantage as we will see in the next chapter.

Chapter 3

Phasor measurements Assisted State Estimation

Over the last decades, there have been several developments in traditional state estimation techniques; however, the fundamental concepts have not changed that much. The basic goal of state estimation is to estimate voltage magnitude and angle at each bus in the system based on the measurements and assumptions about the system. If the voltage is available or assumed, the parameters that depend on voltage, such as real and reactive injection powers, and real and reactive power flows, are computed based on the measured or assumed bus voltages. A state estimator requires ample measurements to find the best possible solution of an over-determined system of equations, whose best solution is given by minimizing mean square error. In the real world a linear system does not exist as almost everything is non-linear. The relationship between the voltages and the other electrical quantities is non-linear. The method that is commonly used to estimate the unknown variables in the power systems are iterative; we assume some initial values for the parameters that we are going to estimate.

As stated previously, in a maximum likelihood state estimation method, the PDF of measurements given parameters is required. Because we assume that noise measurements have Gaussian probability density function, the WLS method gives us the same result as the MLS. So, most of the time the traditional state estimators in power systems utilize the WLS approach, which converts the non-linear equations into the linear form by using first order Taylor's series expansion. Phasor technology, which measures the phase angle of a system, is evolving. With the growing use of this technology in substations, system operators have widely access to new types of measurements. The development of wide area monitoring system (WAMS) based on time-synchronized phasor measurement units (PMUs) has brought a new opportunity in estimating the state of a system. PMUs provide synchronized measurements of voltage phase angles to control system units. The signals from the satellite-based GPS system are used to synchronize PMUs [15].

The measurements obtained from PMU provide many advantages as compared to the Supervisory Control and Data Acquisition (SCADA) measurements. For example the measurements of voltage magnitude obtained from PMU are more accurate than the measurements from SCADA measurements and it has phase angle measurements that cannot

be obtained from RTUs. The other advantage of PMU is that its entire measurements can be synchronized and refreshed at every 20-50ms, which is much faster than the SCADA system [16].

We can say that PMUs are measuring the system state instead of indirectly estimating it. The idea is that the addition of synchronized phasor data as an input to a state estimator could improve the state estimation accuracy and reduce computational time. So, adding PMUs in a grid is a smart choice [17]. As we have seen in WLS, to obtain the required system state the estimator should execute many iterations and accordingly it needs more computational time. But in the case of PMU the state of system can be linearly expressed in terms of measurements which eliminate the need of iterative SE algorithms. However, such estimators do not use the existing traditional SCADA measurements, which reduce the measurement redundancy and are required to super pass the noise system. As mentioned in [18], a state estimator of multi-area for a wide system is working based on the assumption that only the boundary buses are affected from the neighboring utilities. The detailed information about the impact of internal buses on boundary buses will be explained in chapter 4. In [17], another method for state estimation that uses the phasor measurements in state estimation is suggested. In this method, phasor data is used in state estimation by keeping the traditional state estimator, because the cost to change the existing algorithm is expensive.

In the following sections we will see two methods of including phasor measurements into the traditional state estimator. The first technique is to mix the phasor measurements with the traditional measurements and solve as the same technique used in the traditional method. The second one is to use the phase measurements in the post-processing step of the traditional WLS state estimator.

3.1 Inclusion of PMU Data in Traditional State Estimation

Once PMUs started to be installed phase by phase on the critical substations, phasor measurements will be available for state estimation application. Fig3.1. shows how PMUs are connected to the phase conductor of a power line to measure voltage and current of the bus and line respectively.

3.1.1 Integration of Phasor and Traditional measurements

The optimum placement technique of PMU is explained in [52]. The phasor measurements obtained from the available PMUs can be added to the existing SCADA measurements to increase the accuracy of the state estimation. As it can be seen below the first method of adding these measurements to the state estimator comes from mixing real and reactive power flows of the traditional measurements, injections, and voltage and current magnitudes with complex voltage and current phasors. The next step is to follow the mentioned traditional state estimation method [17].

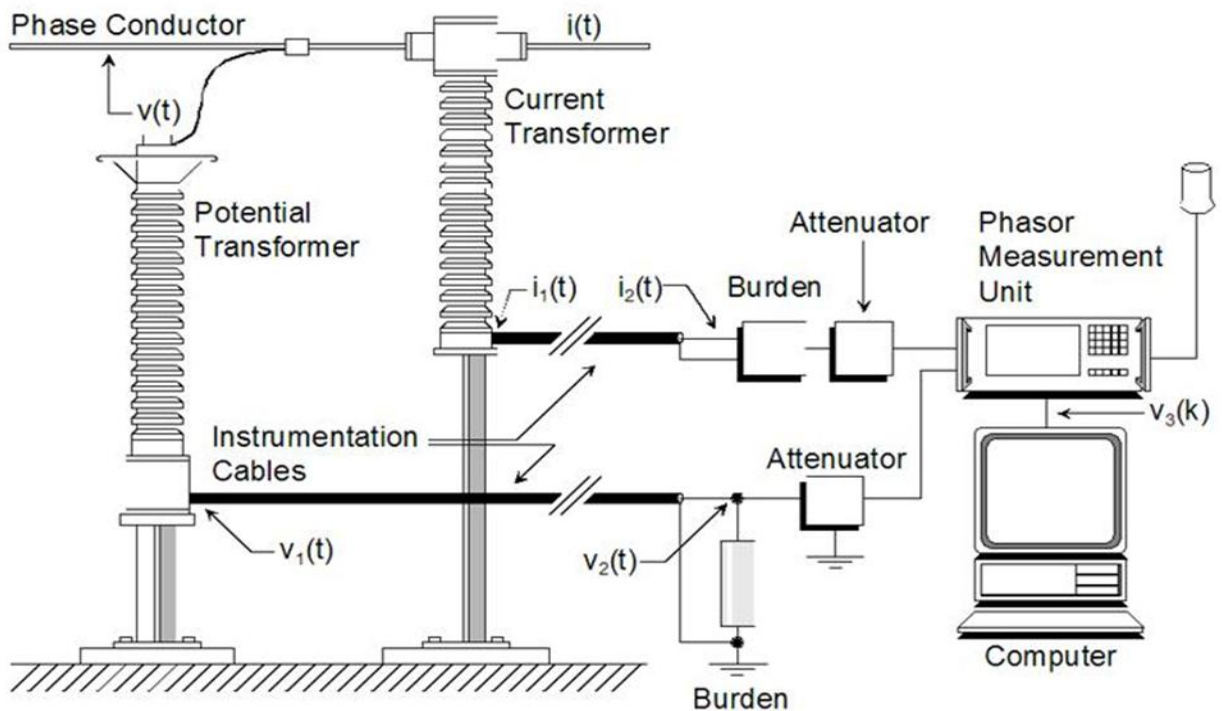

Fig 3.1 PMU Connection on a Substation [12]

As it can be seen from Fig 3.2 a simple system with 4 buses, a PMU can measure not only the voltage phasor, but also the current phasors. It provides the following phasor measurements and their magnitudes, $V_1 \angle \theta_1, I_1 \angle \delta_1, I_2 \angle \delta_2, I_3 \angle \delta_3$.

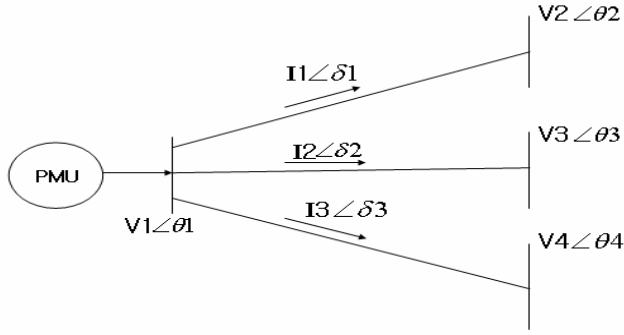

Fig 3.2 Simple PMU measurement model

The same way as we did in Section 2.6, the total Jacobian H can be computed, but now the measurement z will have phase angle, and the line current magnitudes, power injections and power flows and voltage magnitude measurements. PMUs have small variances compared to the Remote Terminal Units (RTUs) and hence have better accuracy.

Let's assume there are two vector measurements vectors z_1 and z_2 ,

$$[z_1] = \begin{bmatrix} z_{11} \\ z_{12} \\ z_{13} \\ \vdots \\ z_{1m} \end{bmatrix} \quad [z_2] = \begin{bmatrix} z_{21} \\ z_{22} \\ z_{23} \\ \vdots \\ z_{2n} \end{bmatrix} \quad (3.1)$$

Where

z_1 = Traditional measurement and

z_2 = Phasor measurements (rectangular form).

We put these measurement vectors in one vector.

$$[z] = \begin{bmatrix} z_1 \\ z_2 \end{bmatrix} = \begin{bmatrix} z_1 \\ v_{real} \\ v_{imag} \\ I_{real} \\ I_{imag} \end{bmatrix} \quad (3.2)$$

As we have seen in chapter two, the equality of optimization of the measurements becomes

$$\begin{bmatrix} z_1 \\ z_2 \end{bmatrix} = \begin{bmatrix} h_1(x) \\ h_2(x) \end{bmatrix} + \begin{bmatrix} e_1 \\ e_2 \end{bmatrix} \quad (3.3)$$

Where

$h_2(x)$ = a polar form vector of the non-linear function to the obtained phasor measurement z_2 . The measurements error covariance matrix will be

$$[z_1] = \begin{bmatrix} R_1 & 0 \\ 0 & R'_2 \end{bmatrix} \quad (3.4)$$

Where

R_1 = traditional measurements error covariance

R'_2 = phasor measurements error covariance.

The state vector is in polar form, and Jacobian matrix measurement will be

$$[H(x)] = \begin{bmatrix} H_1(x) \\ H_2(x) \end{bmatrix} = \begin{bmatrix} \frac{\partial h_1(x)}{\partial x} \\ \frac{\partial h_2(x)}{\partial x} \end{bmatrix} \quad (3.5)$$

Then the weighted square solution is formulated

$$[x^{k+1}] = [x^k + [G(x^k)][H^T_1 R^{-1}_1][z_1 - h_1(x^k)] + [G(x^k)][H^T_2 R'^{-1}_2][z_2 - h_2(x^k)]] \quad (3.6)$$

Where

$$[G(x^k)] = [H^T_1(x^k)R^{-1}_1H_1(x^k) + H^T_2R'^{-1}_2H_2(x^k)]^{-2}$$

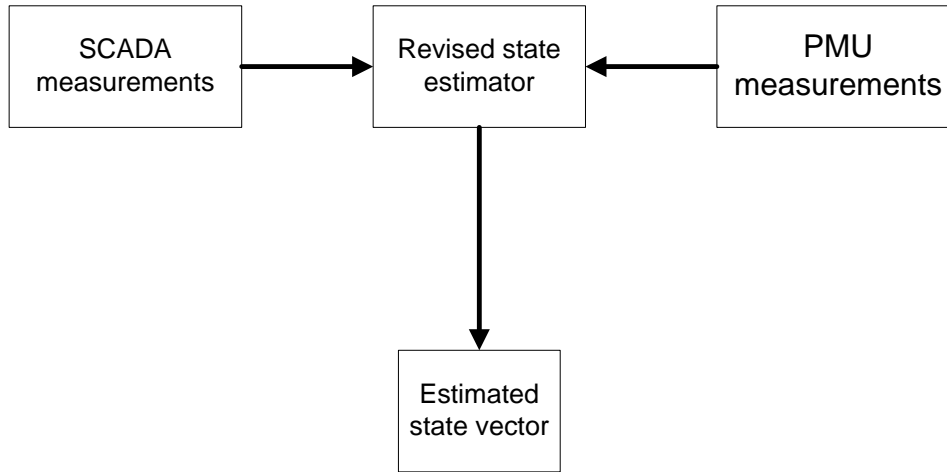

Fig 3.3 Block diagram of Non-Linear Iterative Method

The SCADA measurements, PMU measurements, and Jacobian matrix are available, so the computation is the same as the traditional state estimation. Integrating phasor measurements into the existing state estimator techniques can result to some challenges. These

challenges are because of the need to change the existing code, if integration of phasor measurement and the traditional measurements are required [17]. However, an alternate method of combining phasor measurements to the application of state estimation will be discussed below.

3.1.2 Inclusion of Phasor measurements into Post processing Technique

The technique that will be discussed is provided in [17] and does not change the traditional state estimation algorithm. The phasor measurements are not directly applied in the process of state estimation; instead, they are added in the linear post-processing step. Usually the traditional state estimation techniques follow steps to convert the non-linear functions into linear functions. In this scenario the first thing that the system should determine is to calculate the state of the system via traditional state estimator and then to mix it with the phasor measurements to improve the accuracy of the state estimation and the conversion of associated covariance matrix to rectangular coordinates is required.

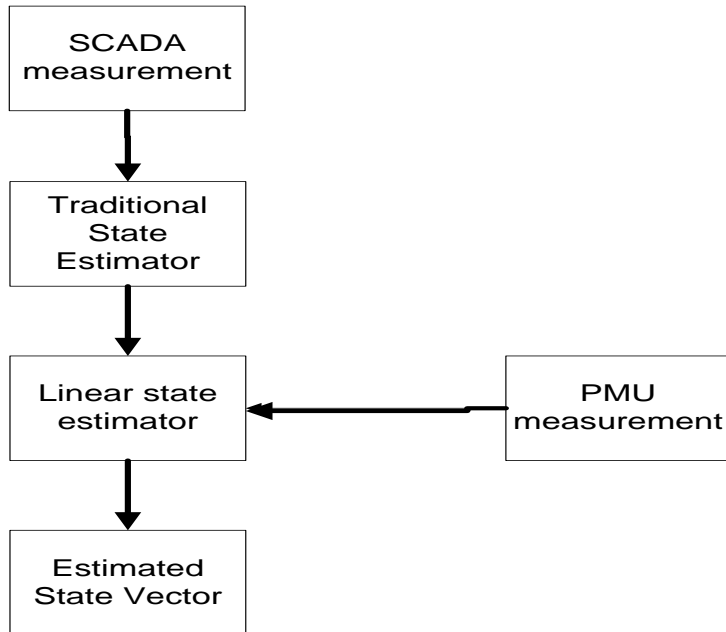

Fig 3.4 Post-Processing Linear Method

The following equation shows the formula:

$$Cov([x])_{rec} = [R'] [cov([x])] [W']^T = [R'_1] \quad (3.7)$$

Where, W = rotation matrix.

Then the relationship of the calculated system state and the available phasor measurements should be as follows.

$$\begin{bmatrix} V'_{real} \\ V'_{imag} \\ V_{real} \\ V_{imag} \\ I_{real} \\ I_{imag} \end{bmatrix} = \begin{bmatrix} I & 0 \\ 0 & I \\ I' & 0 \\ 0 & I' \\ C_1 & C_2 \\ C_3 & C_4 \end{bmatrix} \begin{bmatrix} V_{real} \\ V_{imag} \end{bmatrix} = [A] \begin{bmatrix} V_{real} \\ V_{imag} \end{bmatrix} \quad (3.8)$$

In the above relationship, the identity matrix with a superscript is used to represent states without measurements and at the lower part of the relationship or measurement function there are system parameters that create a linear relationship of the system state to the line current phasor measurements in the measurement vector. The covariance matrix for both measurements is given below.

$$[R] = \begin{bmatrix} R'_1 & 0 \\ 0 & R'_2 \end{bmatrix} \quad (3.9)$$

Then the solution is

$$[x'] = [A^T R^{-1} A]^{-1} [R^{-1} A] [z'] \quad (3.10)$$

From the aforementioned techniques we can observe that PMU technology provides accurate and time-sensitive information for measurement collection. Therefore, the inclusion of PMU data in state estimation is advancement over the traditional state estimation. The following section will present a linear formulation of the state estimation problem using PMUs.

3.3 PMU Data in linearizing State Estimation

Some time ago, the collection of real time measurements from across the power system was new and the current projects in collecting real time data are still in their early stages. This is due to slow change in the static state of the power system which in turn helped system operators to have substantial sending times. Although traditional state estimators are evolving and improving with time, they are yet able to minimize the computation time of their state estimation and are still not sufficient for several desirable applications in protection and control. Thanks to technology today PMUs are allowing the synchronized collection of phasor

measurements. Hopefully in the near future this technology will become dominant in utilities, and state estimation will be the first application to use the data obtained from these units.

As it was discussed in the previous section, PMU measurements could be added in two different ways, which the addition of phasor measurements by a slightly different formulation of the traditional non-linear weighted least squares or the addition of the measurements after a preliminary system state has already been determined [17]. Even though it is not easy to implement PMUs in every substation due to different reasons, still a small number of these precise measurements can affect strongly the accuracy of the overall state of the system [6]. However, a true application of PMU technology to state estimation would include all the traditional measurements of real and reactive power injections and current and voltage magnitudes replaced by bus voltage phasors and line current phasors in the future.

Acceptance of the PMU technology by all utilities and their implementation in desired substations will force the state estimator to function with only PMU measurements. This avoids the problem that existed with traditional state estimator. Synchronization of PMUs with GPS has alleviated the problem of sending time. Once the shortening of sending time has been achieved, the only concern is the issue of time in the communication and computational delay between the collection of the measurements and the employment of useful information for decision-making by the operation and control applications. It could be said that if all the measurements from substations are obtained from PMUs, there is no longer a need for state estimation, but state estimation is very important for including redundancy measurements to help identify bad data and to achieve full observation by getting more measurements [19, 20].

The simple two-port π -model is used to figure out the difference between the measurements used in a traditional state estimator and the measurements used in a linear state estimator. In [6] the formulation of linear state estimation the problem is shown clearly. The state variable of the system will be the voltage magnitude and angle at each end of the transmission line. Assuming a PMU at each end of a transmission line, all the measurements will be voltage phasors; however, because of the capacitance of the transmission lines the line current on each side of a single line will not be the same. Consider the π -equivalent of a transmission line shown in the Fig 3.3 below. In this case consider all values rectangular [12].

This is what gives the state equation its linear property. The system state is then the following complex vector.

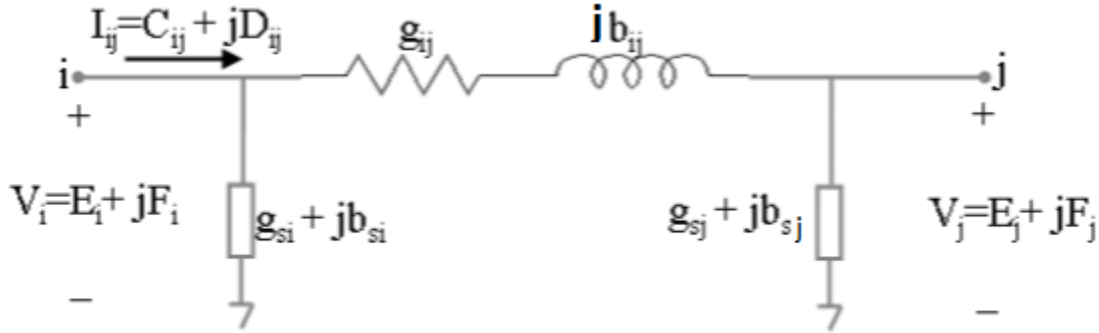

Fig 3.5 Two-Port π -Model of a Transmission Line.

$$[x] = \begin{bmatrix} V_i \\ V_j \end{bmatrix} \quad (3.12)$$

In the Fig 3.5 $(g_{ij} + jb_{ij})$ is the series admittance of the line, and $(g_{si} + jbs_i)$ is the shunt admittance of the line and I_{ij} is line current flow. The measurement vector will be:

$$[z] = \begin{bmatrix} V_i \\ V_j \\ I_{ij} \\ I_{ji} \end{bmatrix} \quad (3.11)$$

From this measurement vector the system state and voltage measurement can clearly be related identically. However, the relationship between the system state and the line flows requires some work that is, first several quantities must be defined. Even though they will not be explained in detail, the series admittance and shunt susceptance of the transmission line are shown below.

$$y_{ij} = (g_{ij} + jb_{ij})^{-1} \quad (3.12)$$

$$y_{io} = g_{si} + jbs_i \quad (3.13)$$

$$y_{jo} = g_{sj} + jb_{sj} \quad (3.14)$$

Sparing the derivation using Kirchoff's laws, the relationship of line current and system state is

$$\begin{bmatrix} I_{ij} \\ I_{ji} \end{bmatrix} = \begin{bmatrix} y_{ij} + y_{io} & -y_{ij} \\ -y_{ij} & y_{ij} + y_{jo} \end{bmatrix} \begin{bmatrix} V_i \\ V_j \end{bmatrix} \quad (3.15)$$

$$I_{ij} = (V_i - V_j)(g_{ii} + jb_{ij}) + [V_i(g_{si} + jb_{sj})]$$

And the complex state equation is

$$\begin{bmatrix} V_i \\ V_j \\ I_{ij} \\ I_{ji} \end{bmatrix} = \begin{bmatrix} 1 & 0 \\ 0 & 1 \\ y_{ij} + y_{io} & -y_{ij} \\ -y_{ij} & y_{ij} + y_{io} \end{bmatrix} \begin{bmatrix} V_i \\ V_j \end{bmatrix} \quad (3.16)$$

Even though this equation could be broken down individually, when it is combined it will form a matrix that will relate a measurement set of the power system network to the system state. We have a definition from earlier sections that says the measurement $z = h(x) + e$

Where: x is a state vector

$h(x)$ = a matrix of the linear equations, and

e = measurement error vector

We can define it in rectangular coordinates to give us

$$z = (Hr + jHm)(E + jF) + e \quad (3.17)$$

Where: $H = Hr + jHm, x = E + jF$ and $z = A + jB$

A and B are expressed by:

$$A = Hr \times E - Hm \times F \quad (3.18)$$

$$B = Hm \times E - Hr \times F$$

In matrix form

$$\begin{bmatrix} A \\ B \end{bmatrix} = \begin{bmatrix} H_r & -H_m \\ H_m & H_r \end{bmatrix} \begin{bmatrix} E \\ F \end{bmatrix} + e \quad (3.19)$$

Then the estimated value $\hat{x} = \hat{E} + j\hat{F}$ can be obtained by solving the linear equation below

$$\hat{x} = (H^T R^{-1} H)^{-1} H^T R^{-1} z \quad (3.20)$$

If we define the linear matrix H_{new} as $H_{new} = \begin{bmatrix} H_r & -H_m \\ H_m & H_r \end{bmatrix}$

Then the estimated value will be

$$\hat{x} = \begin{bmatrix} \hat{E} \\ \hat{F} \end{bmatrix} = (H_{new}^T R^{-1} H_{new})^{-1} H_{new}^T R^{-1} \begin{bmatrix} A \\ B \end{bmatrix} \quad (3.21)$$

Therefore the equation for rectangular form of the variable \hat{x} can be given by the rectangular forms of H matrix and Z vector. They are all real numbers. Assuming we have a simple 2-bus fictitious system shown in Fig 3.6, let's assume the PMU is located at bus-1. It measures voltage V_1 and line current I_{12} . The line current can be expressed as:

$$I_{12} = (k_1 \cdot V_1) + (k_2 \cdot V_2)$$

Where k_1 and k_2 are constant complex values.

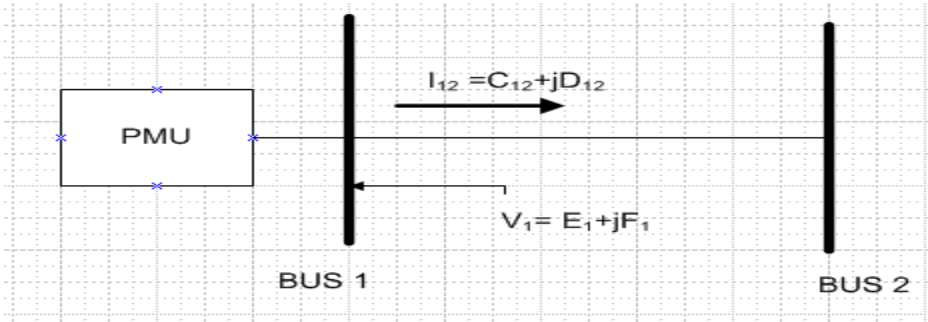

Fig 3.6 Simple Two bus system with PMU measurements:

The measurement vector z has two entries, which are voltage measured at bus 1 and the current flow measured between bus 1 and bus 2.

$$z = \begin{bmatrix} V_1 \\ I_{12} \end{bmatrix} = \begin{bmatrix} 1 & 0 \\ k_1 & k_2 \end{bmatrix} \begin{bmatrix} E \\ F \end{bmatrix} + e \quad (3.22)$$

If we express (3.19) in rectangular coordinates:

$$\begin{bmatrix} 1 & 0 \\ k_1 & k_2 \end{bmatrix} = \begin{bmatrix} 1 & 0 \\ k_{r1} + jkm_1 & k_{r2} + jkm_2 \end{bmatrix} = \begin{bmatrix} 1 & 0 \\ k_{r1} & k_{r2} \end{bmatrix} + j \begin{bmatrix} 1 & 0 \\ km_1 & km_2 \end{bmatrix} = Hr + jHm$$

Where $V_1 = E_1 + jF_1$, $I_{12} = C_{12} + jD_{12}$

$$k_1 = kr_1 + jk_{m1}, k_2 = kr_2 + jk_{m2}$$

Therefore the measurement vector z becomes

$$z = \begin{bmatrix} E_1 \\ C_{12} \\ F_1 \\ D_{12} \end{bmatrix} = \begin{bmatrix} 1 & 0 & 0 & 0 \\ kr_1 & kr_2 & -km_1 & -km_2 \\ 0 & 0 & 1 & 0 \\ km_1 & km_2 & kr_1 & kr_1 \end{bmatrix} \begin{bmatrix} E_1 \\ E_2 \\ F_1 \\ F_2 \end{bmatrix} + e \quad (3.23)$$

Finally \hat{x} is calculated using

$$\hat{x} = \begin{bmatrix} \hat{E} \\ \hat{F} \end{bmatrix} = (H_{new}^T R^{-1} H_{new})^{-1} H_{new}^T R^{-1} \begin{bmatrix} A \\ B \end{bmatrix}$$

$$\hat{x} = \begin{bmatrix} \hat{E} \\ \hat{F} \end{bmatrix} = \begin{bmatrix} E_1 \\ E_2 \\ F_1 \\ F_2 \end{bmatrix}, \quad z = \begin{bmatrix} A \\ B \end{bmatrix} = \begin{bmatrix} E_1 \\ C_{12} \\ F_1 \\ D_{12} \end{bmatrix} \quad (3.17)$$

This is very simple and fast, because it doesn't need any iteration. This procedure shows us if a PMU is installed in a bus it measures a synchronized voltage phasor and several synchronized current phasors. If system measurements consist only of PMU measurements, the state estimation can be formulated as a linear problem. As we saw earlier, the state vector and the measurement data are expressed in rectangular coordinate system.

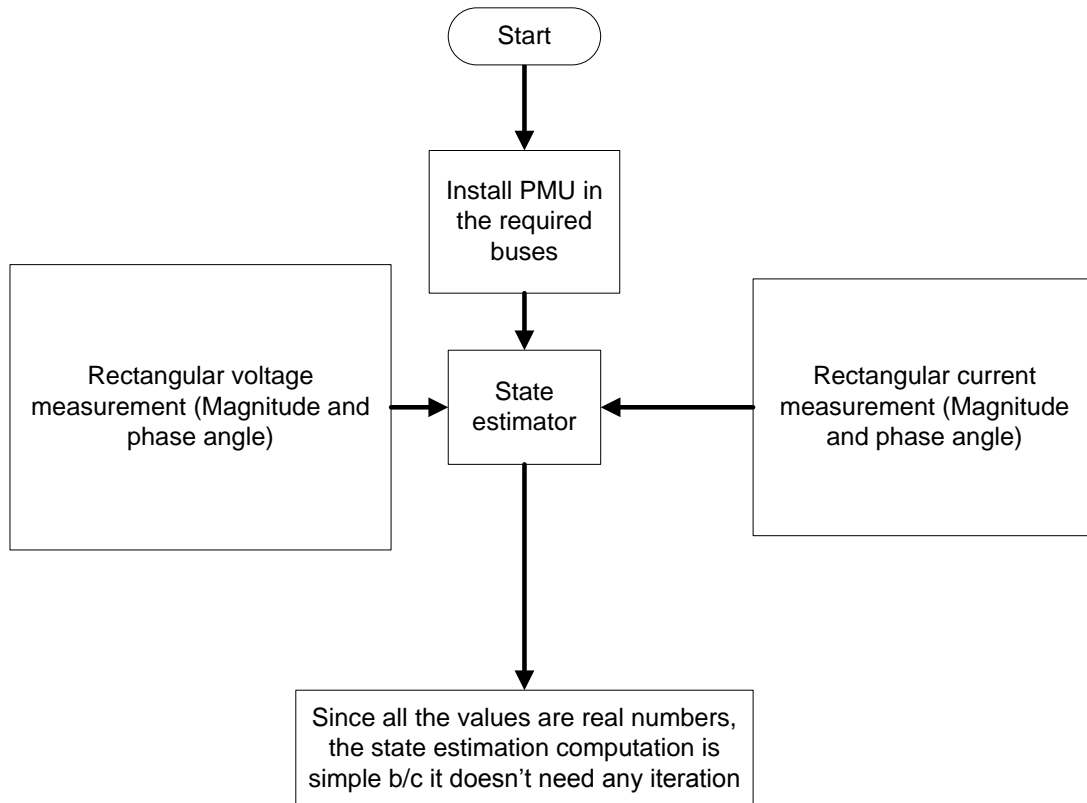

Fig 3.7 Non-Linear Iterative Method

Therefore as a clear application of PMU technology to state estimation, this chapter presented the formulation of the linear state estimation problem using exclusively PMU measurements. A basic formulation using a two-port π -model was first used followed by discussions of the matrices that are used to develop the system matrix (similar to the measurement function of traditional state estimation techniques). This chapter has been structured to show the details of how the nonlinear functions are changed to linear functions when the phasor measurements are from phasor measurements only. The next chapter will provide the details of distributed state estimation and its advantages over traditional state estimation and it will present the use of PMUs in distributed state estimation.

Chapter 4

Distributed State Estimation with phasor measurement unit

4.1 General Concept

Deregulation brought many changes on the electric power industry over the last two decades [22]-[25]. One of the changes is competition among the utilities. The point is to show whenever there is a competition always there will be a better way of giving service to a consumer and accordingly the pace to an efficient power generation and more technological innovation increases and eventually the cost of electricity will decrease. Currently our power grid is owned by multiple companies, so to run the system effectively, the companies need to cooperate with each other. Earlier we have seen the traditional way of estimating a state, but in this chapter, we will see how the use of distributed state estimation and the use of phasor measurements enhance the ability to monitor and control the power system. Monitoring and controlling the power system network in real time is very important. One example to show the importance of controlling on a real time basis is the Northeast blackout of 2003 in USA and Canada. The main reason for the blackout was the absence of real time controlling, and there was a failure of power-grid organization to keep it from spreading [26].

The activity of the energy management system (EMS) strongly depends on the data provided by state estimation to perform system security analysis, economic dispatch, and other functions, so the data should be as accurate as possible. Hence, the state estimator has to be more computationally efficient and robust, which cannot be achieved by only improving the current state estimation algorithm itself. Instead there should be a technique that provides accurate real time data to the state estimator better than the current technique and accordingly enables controlling the system before any fault can occur and cascade on the system. The challenges in traditional state estimation are the computational time and data accuracy. With new technologies and studies this could be minimized to a required level. Since the power system size is very large, in order to minimize the computational time, decentralizing the state estimation could be a great approach. There are many studies in DSE and some of them are two-step distributed state estimation, which perform individual state estimation and system wide SE as in [8, 9, and 10]. In addition two-level state estimator which computes system estimation by coordinating the subsystem states and setting the slack bus of the system in one of the boundary buses is shown in[27]. DSE algorithm by rectangular coordinates is also

given in [28]. As seen in Fig 4.1 a hierarchical method is also another technique [29]. In this method the subsystem state estimation is coordinated at the second level. But we have to keep in mind that when the sampling rate is increased in a system there will be communication and reliability challenges.

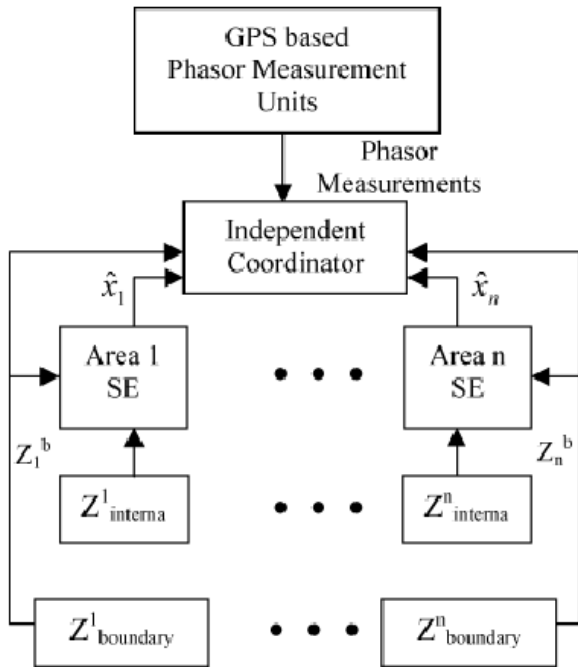

Fig 4.1 Hierarchical SE Diagram [29]

There are other proposals of DSE as can be referred in [30, 31, 32, 33, 34, 35, and 36]. Hierarchical SE approaches can be seen in [37]. In this report the technique followed by [50] is considered the best way of improving a wide area system reliability and efficiency by getting its full-scale snapshot. In a bulk electric system, its topology has influential impact on its operation. For example if a subsystem has more connections with its neighboring systems, the system is not only affected by its own system operation, but it is also affected by the other subsystems. So its SE will be affected by the flow of currents and power on the tie lines. A review of the literature in [33]-[36], provides an idea of how to solve a SE of a system with more tie lines. If we assume DSE without PMU, each sub-system will make its own state estimation and send the result to the independent system coordinator. It will help to provide a system snapshot and if any fault is detected on the sub systems, the local SE will identify it immediately. In the following sections we will see how a system snapshot can be obtained

from DSE using phasor measurements at the slack bus of each system. And all the derivations are followed from reference [50].

4.2 DSE Algorithm and Scheme

The main concept is the same as we have seen in the traditional state estimation. The only difference is that, in this case the system is decomposed into sub-systems and PMUs are placed on the slack bus of each system. To start easy lets first see the basic algorithms we have seen in Chapters 2 and 3. Our model from Chapter 2 gives

$$z = h(x) + e$$

To get the optimum solution of (2.9) lets obtain the minimum solution of the performance index $J(x)$, which is the weighted measurement (Chapter 2).

$$J(x) = J(x) = \frac{1}{2} \sum_{j=1}^m \left(\frac{z_j - h_j(x)}{\sigma_j} \right)^2 \dots \dots \dots (2.11)$$

The following iterative problem is used to get the state estimation of the sub system. It has the same flow chart characteristics as Fig 2.6

$$G = H'WH$$

$$\begin{aligned} \nabla Z(x^k) &= z - h(x^k) \\ (H'(x^k)(RZ)^{-1}H(x^k)) \nabla Z(x^k) &= H'(x^k)(RZ)^{-1} \nabla h(x^k) \\ x^{k+1} &= x^k + \nabla x^k \end{aligned} \quad (4.3)$$

Where

$$\begin{aligned} R_z &= \text{covariance matrix} \\ 'H' &= \text{Jacobian matrix.} \\ 'G' &= \text{gain matrix} \\ 'W' &= R^{-1} \\ R_{\hat{x}} &= G^{-1}H'W)RZ(G^{-1}H'W)' \end{aligned} \quad (4.4)$$

Where

$$\begin{aligned} W &= RZ^{-1}, \text{ then} \\ R_{\hat{x}} &= G^{-1} \end{aligned} \quad (4.5)$$

And the normalized form of covariance matrix will be

$$R_{x \wedge n} = (diag(R_{x \wedge}) \wedge((-1)/2) R_{x \wedge} diag(R_{x \wedge}) \wedge(-1/2)) \quad (4.6)$$

Therefore covariance of estimated measurement z

$$R_z = HR_{\hat{x}}H' = HG^{-1}H \dots \dots \dots (4.7)$$

The covariance matrix of the estimate of the residual vector 'r' is obtained

$$R_{\hat{x}} = R_z - HG^{-1}H' = (I - HG^{-1}H'R_z^{-1})R_z = SR_z \dots \dots \dots (4.8)$$

Where

I = identity matrix,

S = residual sensitivity matrix.

This is the general state estimation model and our goal is to estimate the state of a decomposed power system as can be seen in Fig 4.2 [50]. The system is decomposed into three sub systems. Each subsystem has a sensitive internal bus and insensitive internal bus as can be easily seen in the system. All the buses which are connected to the tie line are boundary buses.

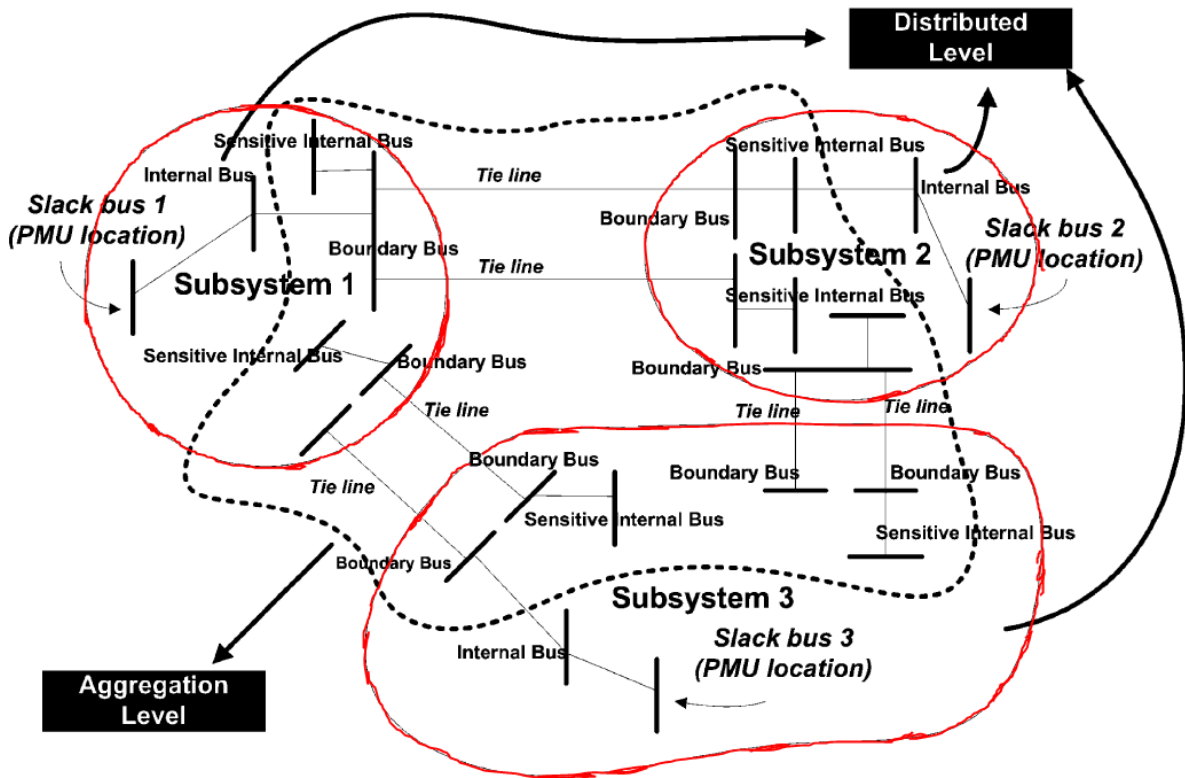

Fig 4.2 Power system with three subsystems [50]

The subsystems in Fig 4.2 are named as S1, S2, and S3. According to our assumptions each system has its own slack bus and our proposal is to put PMU on these buses. The system buses are grouped as: internal bus, sensitive and insensitive internal bus and boundary bus: as we did earlier, our goal is first to compute the system state estimation ‘ x ’ from subsystem state x_i .

$$\begin{aligned} x &= [x_1, x_2, x_3] \\ x_i &= x_i^I, x_i^B \\ x_i^I &= [x_i^{I-sensitive}, x_i^{I-insensitive}] \end{aligned} \quad (4.9)$$

Where

x_i^I = states of internal buses in subsystem i;

x_i^B = states of boundary buses in subsystem i ;

$x_i^{I-sensitive}$ = sensitive internal bus in subsystem i;

$x_i^{I-insensitive}$ = an insensitive internal bus in subsystem i.

$$z_i = [z_i^I, z_i^B] \quad (4.10)$$

$$z_i^I = [z_i^{I-sensitive}, z_i^{I-insensitive}] \quad (4.11)$$

$$z = [z_1, z_2, z_3] \quad (4.12)$$

$z_i^{I-sensitive}$ and $z_i^{I-insensitive}$ are measurements of internal sensitive and insensitive bus; and in (4.12), z_t denotes tie line power flow measurements.

The bus sensitivity matrix shown in (4.6) is obtained from the aggregation of SE and based on that, sensitive internal buses are determined from these results. The sensitivity of the buses is found by studying the power flow among the connected buses, but also could be studied by the contingency analysis and other power flow analysis’s. The next step, PMUs are assumed to be in all the slack buses of each system, and then the voltage of each slack bus will be determined by a PMU. So the distributed solution of the system will be synchronized from the SE of each subsystem

$$z_i^I = h_i(x_i) + e_i \quad (4.13)$$

The next algorithm includes vectors measurements, such as the tie line power flows, boundary injections and other internal measurements related to the sensitive internal buses, and pseudo measurements like the solutions of the boundary buses and sensitive internal buses from neighboring subsystems. The most important section is to obtain the SE of the boundary

bus and the sensitive internal buses and finally to obtain system state estimation by combining the SE of each subsystem and compute the system snapshot. It has the following form:

$$\begin{bmatrix} z^{b_{1,2,3}} \\ z_t \\ \text{---} \\ z_{pseudo} \end{bmatrix} = \begin{bmatrix} h_c(x_a) \\ \text{---} \\ H_s x_a \end{bmatrix} + e_a \quad (4.14)$$

Where

x_a = boundary bus state variables and sensitive internal bus state variables;

$z^{b_{1,2,3}}$ = the boundary injection measurements;

z_t = tie line power flow measurements;

z_{pseudo} = boundary nodes and sensitive internal buses solution

$h_c(x_a)$ = function which gives relationships between measurements and the state variables of boundary nodes and sensitive internal buses.

H_s = linear function which provides pseudo measurements and state variables relationship. e_a = error vector.

vector $H_s x_a$ can be defined

$$v_{pseudo} = v_a + e_v$$

$$\theta_{pseudo} = \theta_a + e_\theta \quad (4.15)$$

The above computations are used to provide system wide state estimation based on the data obtained from the solution of the subsystems. To obtain the accurate data the PMU should be installed at an appropriate bus, so they are installed at the slack buses. The drawback of this case is that the PMU measurements are becoming critical measurements and in the case of any failure, bad data can lead to a wrong decision.

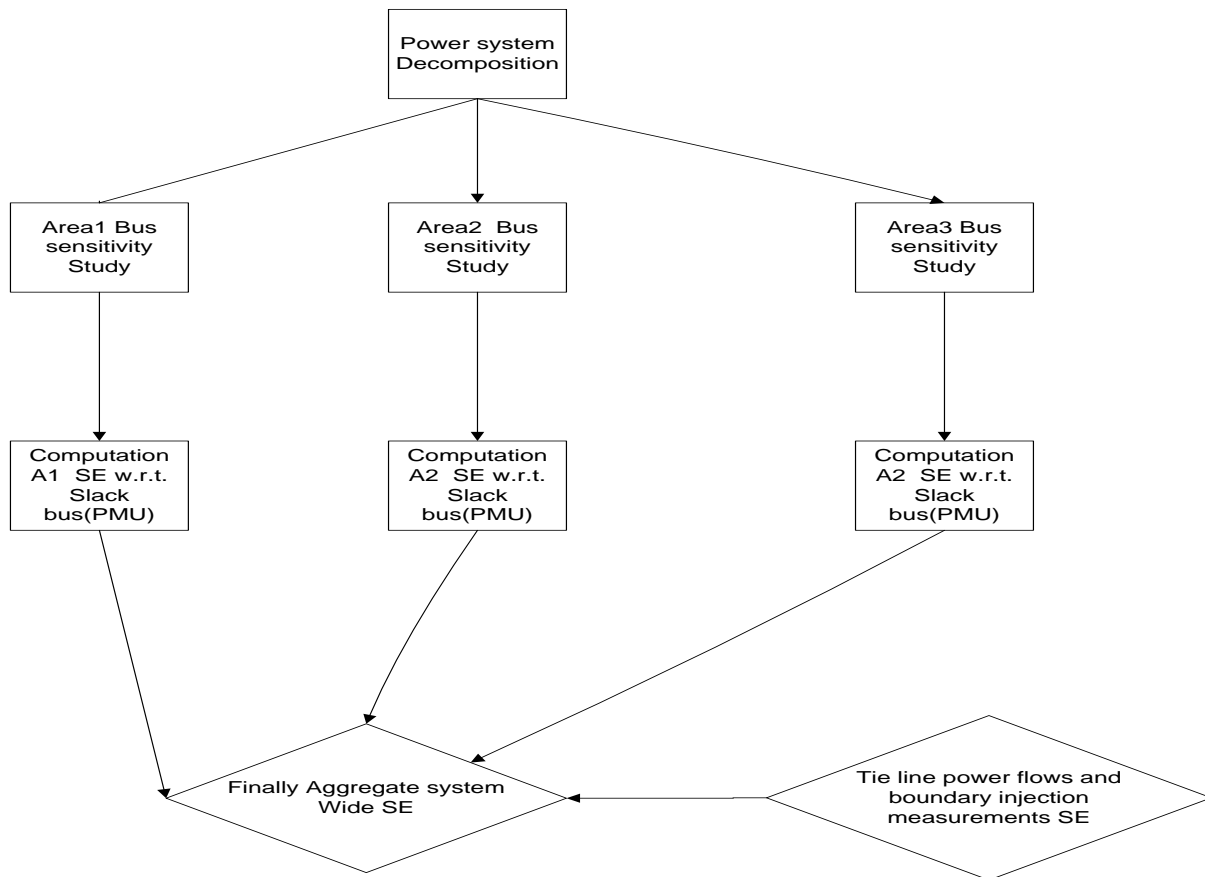

Fig 4.3 Proposed DSE

Currently the cost of PMUs is very expensive and it is not possible to implement them in every substation, so an optimum PMU placement technique should be applied [40]. As it can be found in the literature, several options of 'optimally' placing the PMUs [51, 52] are available. The basic procedure can be checked in Fig 4.4 below.

The next challenge is how to identify bad data from the given data as it can lead to a wrong decision. Information regarding bad data in a subsystem and tie lines and processing it is discussed in [33]. The bottom line is that in order to identify bad data, redundant system measurements are required. In our case it is assumed that each subsystem has enough redundancy in the subsystem measurement set to identify bad data in the internal measurements and accordingly, the bad data can be avoided. There are more measurements,

which result in a higher redundancy level and will improve the bad data processing ability of tie line measurements and boundary measurements.

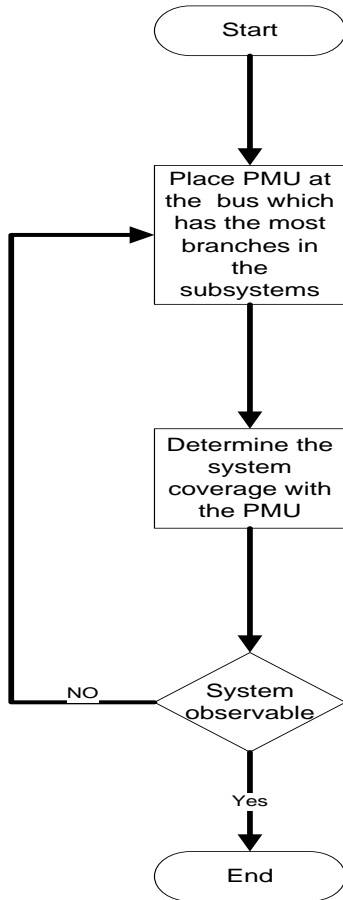

Fig 4.4 One type of PMU placement algorithm

4.3 Proposed DSE Summary

This section presents results of some experiments done in the case study of IEEE 118 bus system [48]. It illustrates the concept of decentralized distributed SE and it assumes to have 118 voltage magnitude measurements, 356 pairs of power flow measurements, 3 synchronized phasor measurements and 118 pairs of injection measurements. The system is first decomposed to three subsystems by checking the tie lines in the system as can be seen in Fig 4.5. The next step is to put the PMU in a slack bus of each sub system following the PMU algorithm. The following Table shows the PMU allocation in each of the sub systems.

Table 4.1 PMU allocation

PMU placement	
Bus#	System
33	1
72	2
110	3

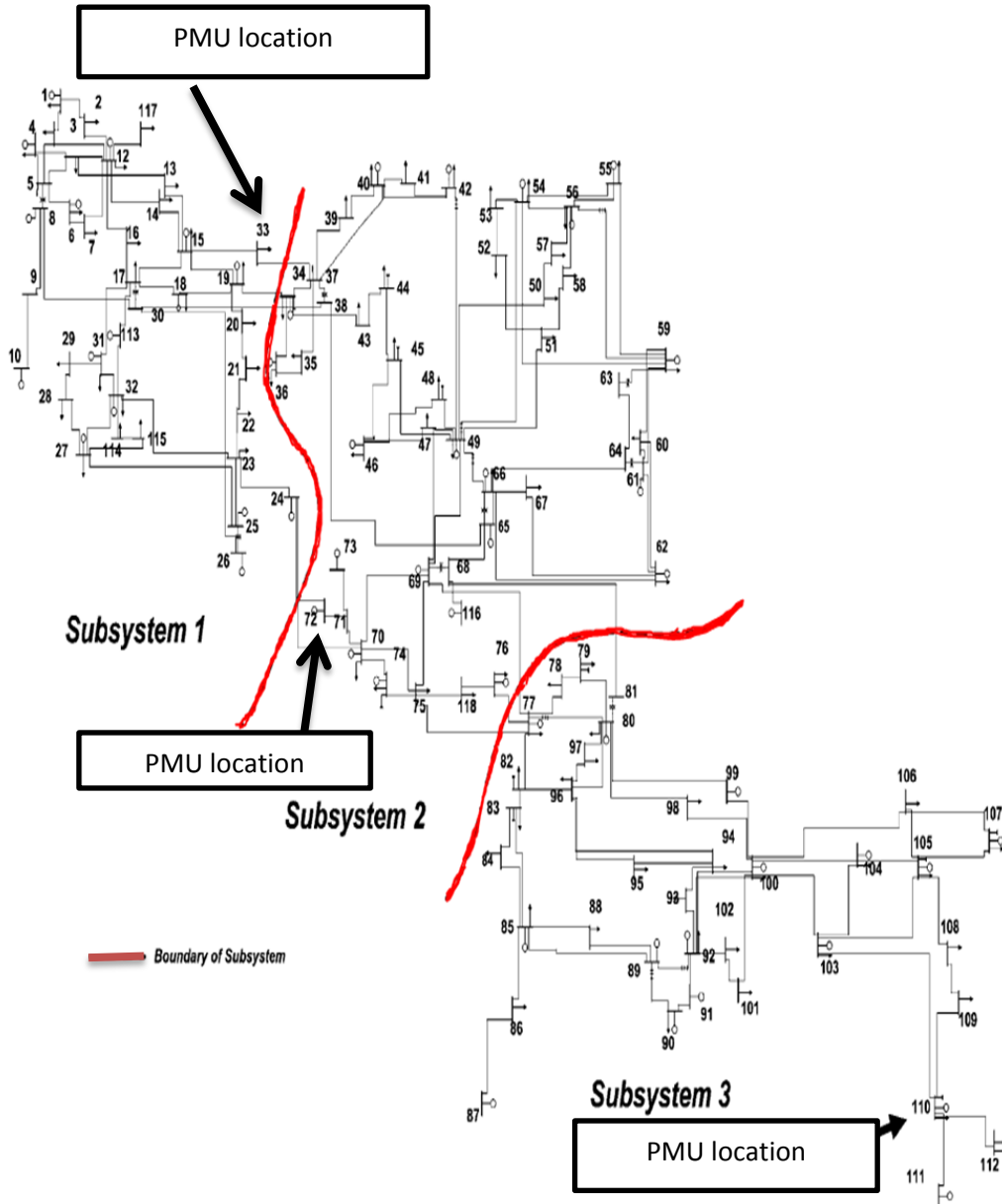

Fig 4.5 Decomposition of the IEEE 118 Bus [50]

As can be seen from [50] sub-system 3 was used to show the procedures to select best slack bus location. It has 36 voltage magnitudes, 106 pair of power flow and 34 pairs of injection measurement and without the boundary bus injection measurements the total number of measurements and states are $m = 316$ and $n = 71$. From the result in [50] by using PSAT power flow program, there is no critical measurement in the measurement set, therefore more weight is provided on the SE accuracy improvement. They calculated SE error variances and measurement redundancies to measure the optimization of SE performance. The detailed information about how to obtain the redundancy measurements can be shown in [50].

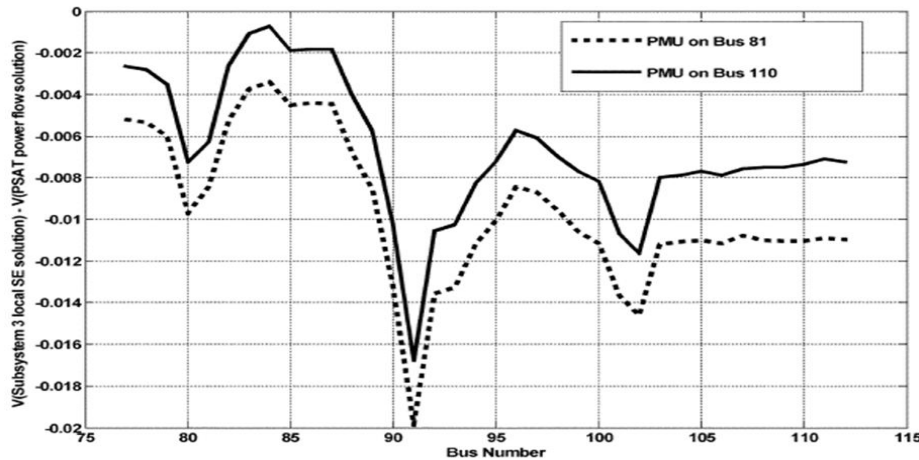

Fig 4.6 Voltage magnitude comparison of subsystem 3 distributed SE with PMU on bus 110 and bus 81[50].

The power flow solution and the voltage magnitude difference of system 3 are shown in Fig 4.6. The solid black line represents the voltage magnitude difference with PMU installed on bus 110 and the dotted black line denotes the voltage magnitude difference with PMU installed on bus 81; SE is better when the PMU is in bus 110. The result was compared with the results from the power flow calculation program. The vertical axis is the difference between the voltage obtained from power flow calculation and the voltage obtained from the estimation proposed by placing PMU on different buses. As mentioned above, when the PMU is on bus 110 the voltage difference become less than the voltage difference when the PMU is

on bus 81. This indicates that the state estimation of subsystem 3 is better when the PMU is on bus 110.

Based on the redundancy analysis results different possible locations of PMU were selected and bus 110 was selected as a slack bus and PMU location. From the given data in table 4.3 buses 86, 87, 110, 111, and 112 could be the best PMU locations and from table 4.4 due to the bus-branch connectivity condition bus 110 is best for PMU placement to provide excellent SE.

Table 4.2 IEEE 118 Bus Test-bed Bus-branch Connectivity Data [50]

118 Bus Test-bed Bus-branch Connectivity Data					
Bus#	110	86	112	111	87
number of branch	4	2	1	1	1

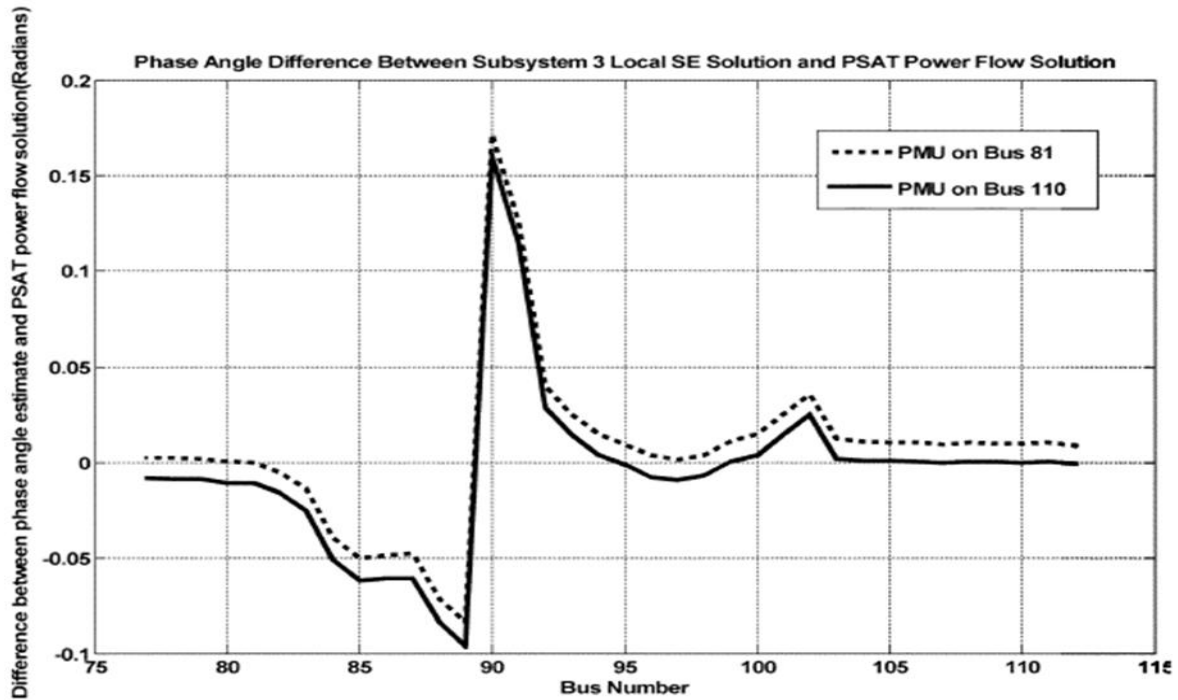

Fig 4.7 Phase angle comparison of subsystem 3 local SE with PMU on 110 and PMU on 81[50]

Fig 4.7 shows us that state estimation of subsystem 3 obtained when the PMU is in bus 81 is similar to the state estimation when the PMU is in bus 110. But still the state estimation of the other buses around bus 110 have better state estimation, which the phase angle of these buses is better than the buses around bus 81.

Table 4.5 shows the sensitivity analysis of the boundary buses from external subsystems. In the introduction of this section, about the distributed state estimation algorithms, first we categorized the system buses into four sections: internal bus, boundary bus, sensitive internal bus and in sensitive internal bus. The internal buses of the sub systems are divided into two parts. First are the sensitive internal buses, which are buses that have strong behaving characteristics with the boundary bus, and the second are insensitive internal buses that do not affect much to the state of the boundary bus. The impact of the internal buses is affecting only the boundary buses. A sensitivity analysis based on updates at chosen boundary buses can be used to obtain the distributed solution to the aggregate state estimation. Sensitive internal buses within each subsystem are identified by sensitivity analysis, which evaluates the degree of impact from the neighboring subsystems. In order to re-estimate the boundary buses and the sensitive internal buses the result from PSAT (power flow program) is taken to decide which buses of the internal buses are affecting the boundary buses operating characteristics.

The aggregation level bus of the boundary bus between system 1 and 2 and bus 2 and 3 is shown in Fig 4.8 and Fig 4.9 respectively. Fig 4.8 shows the aggregation level bus set for the upper portion see Fig 4.2 of the boundary between subsystem 1 and subsystem 2 while Fig 4.9 shows the aggregation level bus set on the boundary between subsystem 2 and subsystem 3.

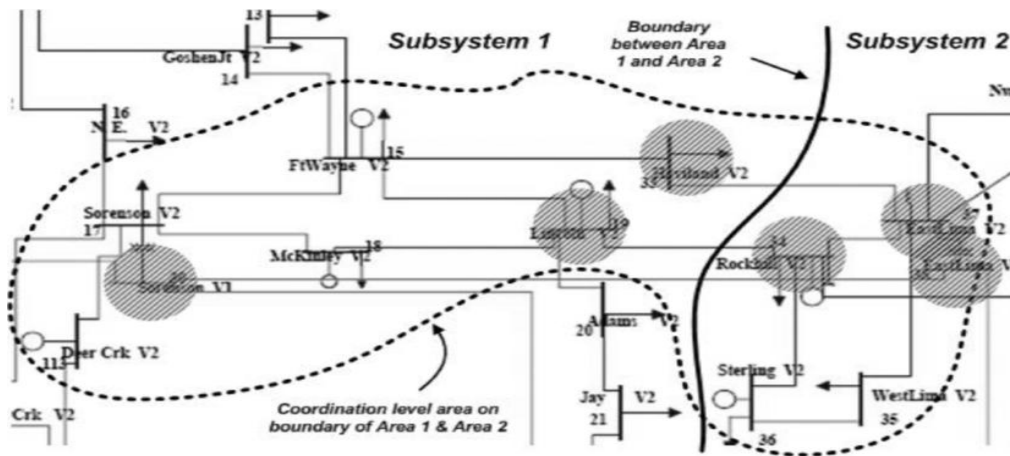

Fig 4.8 Aggregation level bus set on boundary of subsystems 1 and 2 with strong connection [50].

As can be seen from both Fig 4.8 and Fig 4.9 there are multiple buses at the boundary, expanded aggregation is used to make the SE.

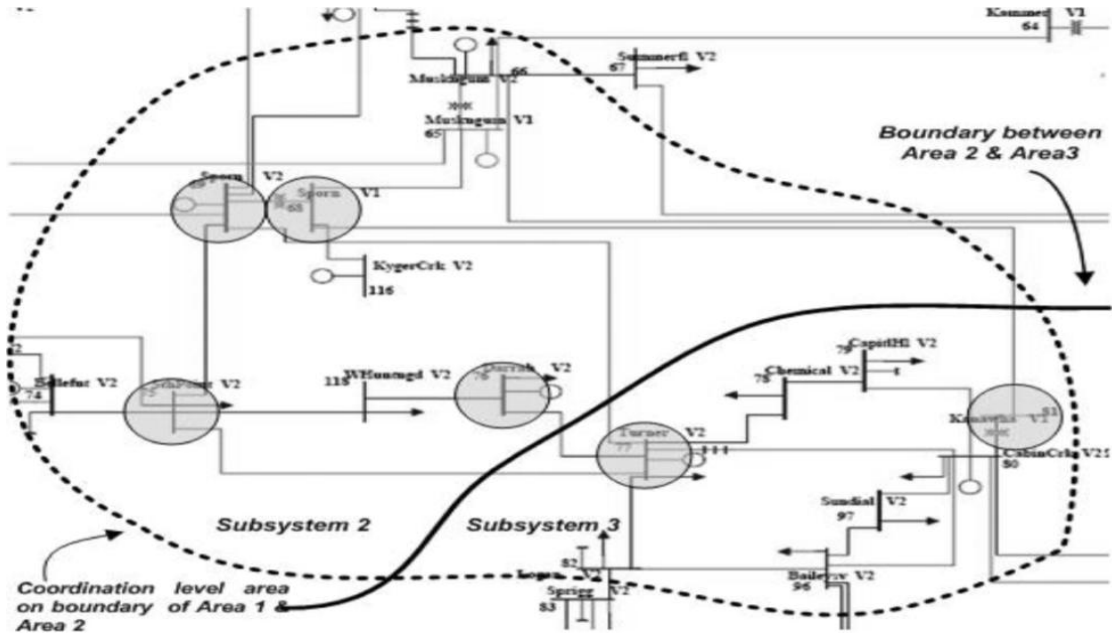

Fig 4.9 Coordination level bus set on boundary of subsystem 2 and 3.[50]

Fig 4.10 and 4.11 show the difference between the averages distributed SE solution with and without the sensitive internal buses updated and the average integrated SE solution. It is observed that the proposed distributed SE gives a solution close to the integrated SE.

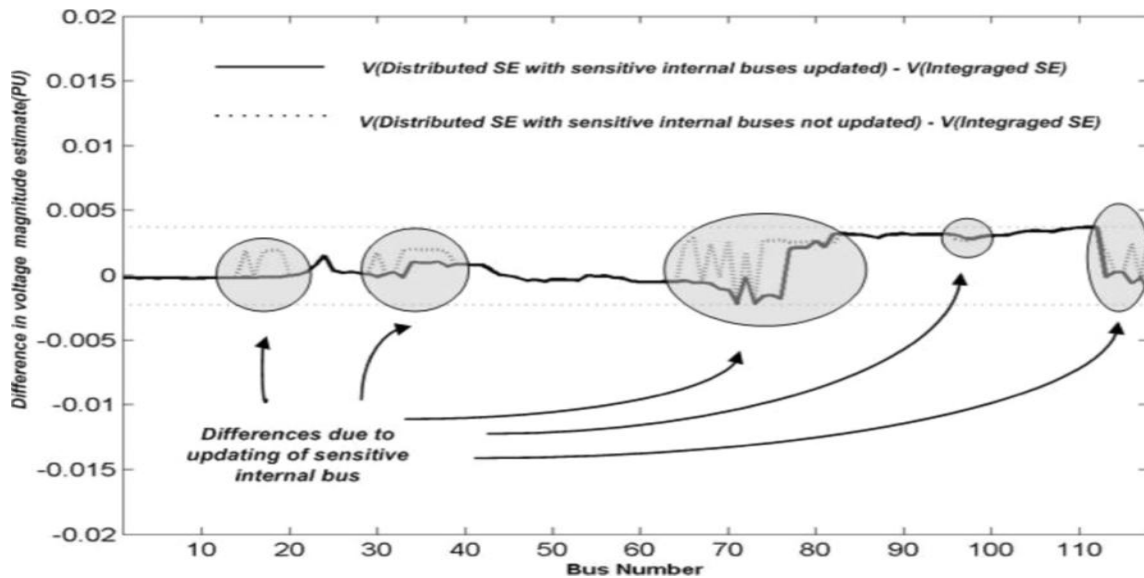

Fig 4.10: Voltage magnitude comparison of distributed SE solution and integrated SE solution [50].

When the data from the sensitive internal buses is re-estimated the results shows better accuracy and it helps to show the snapshot of the whole system.

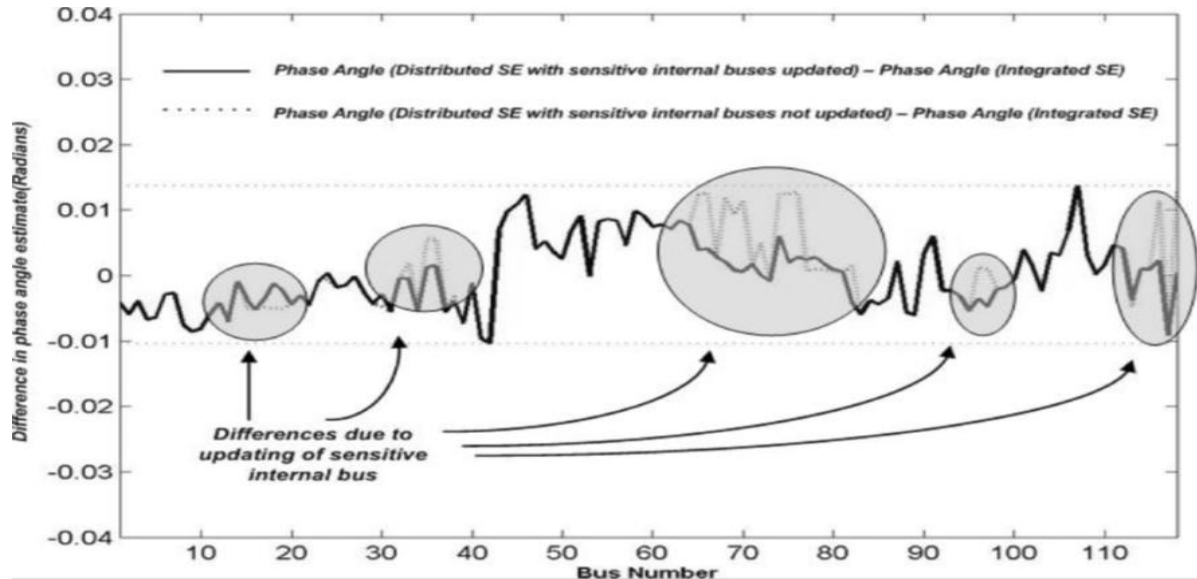

Fig 4.11: Phase angle comparison of distributed state estimation solution and integrated SE solution [50].

Table 4.3 Comparison of Integrated and DSE Solutions [50]

Test bed	Value of J(x)		Comparison Of Integrated and Distributed SE Solutions (without considering communication time, seconds)	
	Integrated	Distributed	Integrated	Distributed
IEEE 118	6.93	7.18	10.47	1.86

The results obtained from the tests show that the use of distributed state estimation using phasor measurement units reduced the computational time and provided the required accuracy. Even though the result shows that the errors are more when we are using the DSE, it is in the acceptable range as per [50] because the measurements are not all PMUs. This report presents all state estimation problems and their solutions. Since utilities are not interested to share detailed information, distributed state estimation is the approachable method to optimize state estimation of a system. It reduces computational time and improves the accuracy of the SE

even though the errors are more in DSE than the integrated SE. The results are reasonable as the errors are due to using the same measurement and the process of sub system state estimation local errors.

As presented in [51], the application of hierarchical DSE in powers system with the help of phasor measurement unit. It proposed a technique to compute the angle difference of the slack bus in each sub area, and compare this method with the traditional SE. In addition the dissertation paper provides the use of PMU both in traditional state estimation and DSE. This technique and the technique we discussed earlier are similar except in the earlier technique [50], the sensitive buses are included to the re-estimating process. The procedures followed in [51] were: obtain measurements; use the power flow of the real measurements of the system for the local SE; decentralize the system into subsystems to apply the WLS based local SE; then coordinate the obtained SE of the sub systems. In [50] the subsystem SE and the sensitive and boundary bus state estimation are first obtained and then the results are coordinated to provide combined SE and finally the sensitive and boundary bus SE are re estimated to provide the updated system operating point. It shows the test results for centralized SE with and without PMU, distributed state estimation with and without PMU and post processing SE using phasor measurements. The basic flow charts for all the three cases are shown in Fig 4.12, 4.13, and 4.14 respectively. The overall results show that using PMU in all types of state estimation provides accurate result and DSE needs less computational time and it is more robust than the centralized SE.

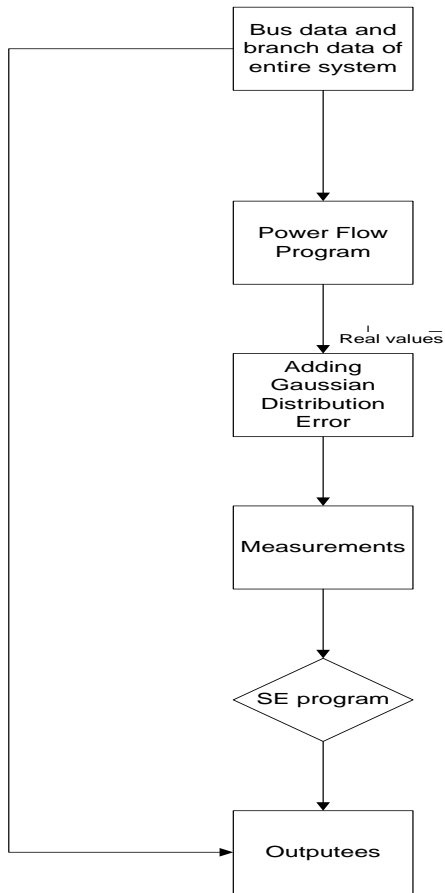

Fig. 4.12 centralized state estimation's flow chart

Fig 4.12 shows the traditional state estimation it is based on the normal power flow technique. It estimates the value of the system based on the available measurements using the WLS and makes multiple iterations to get the tolerable value of the state variable.

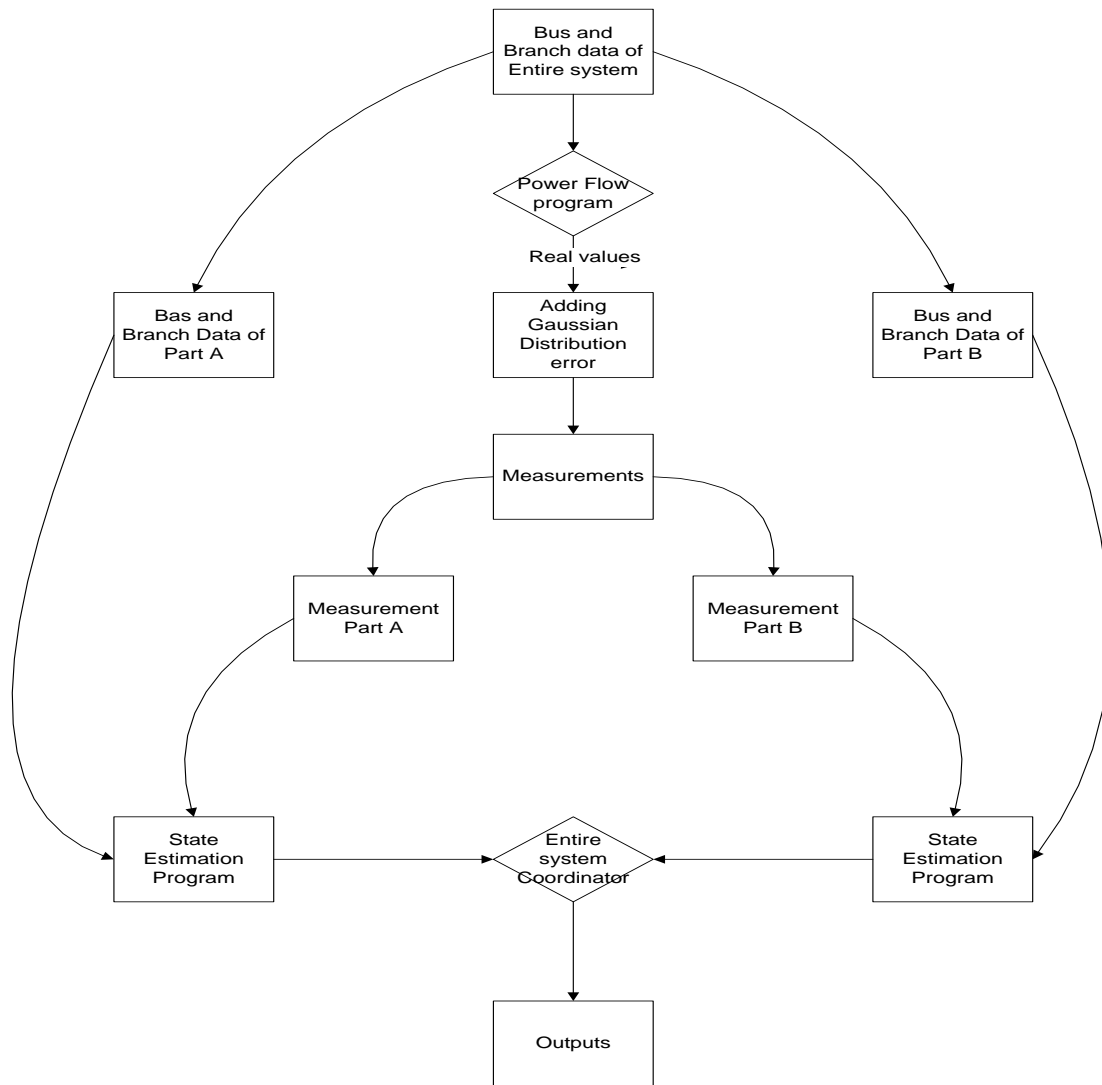

Fig. 4.13 Distributed Centralized State Estimation's Flow chart

Fig 4.13 is DSE, which is the same with the traditional one, but the system is divided into subsystems and each subsystem makes its own state estimation and finally, the results from the subsystems are coordinated to provide the system wide state estimation.

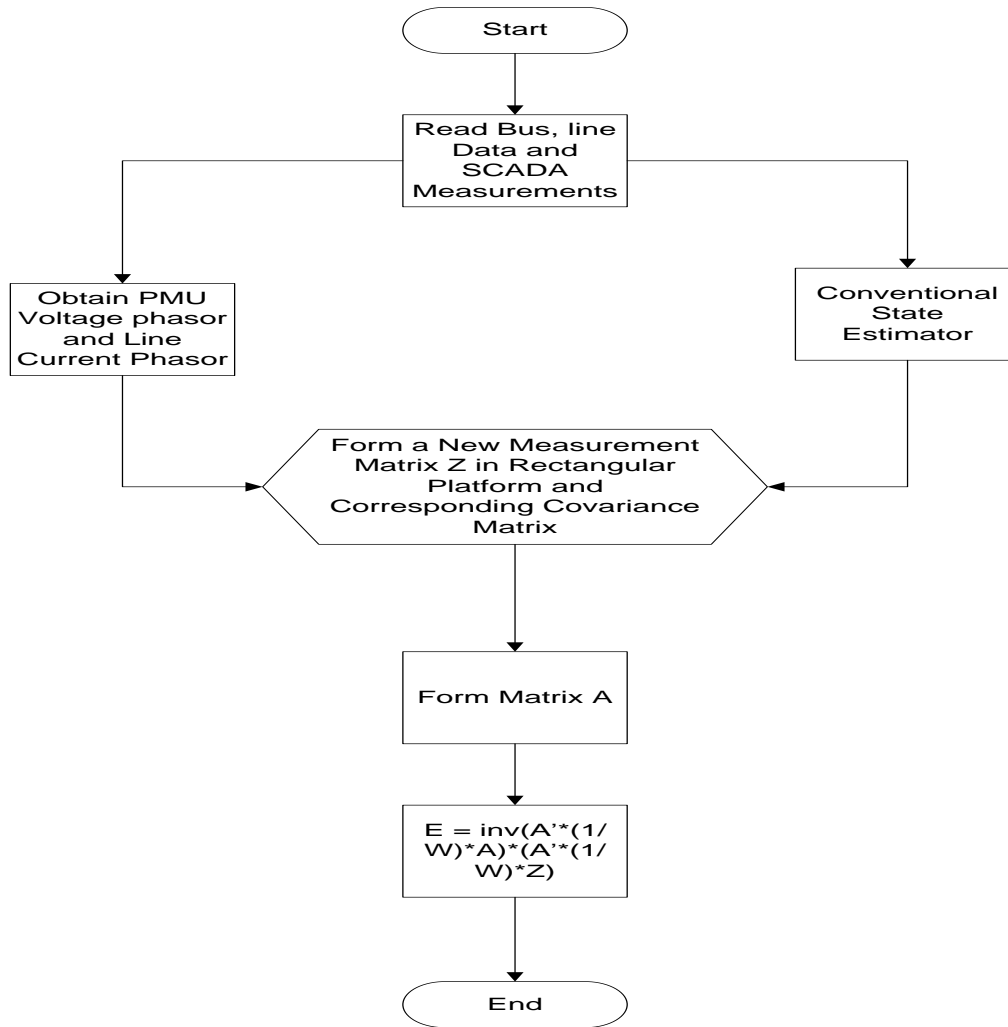

Fig.4.14 Post Processing PMU Data's Flow chart

In the post processing technique the measurements should be in rectangular coordinates. Z consists of the phasor measurement vectors and the estimated result of the centralized state estimation vectors. The results from the test cases show that adding PMU to the traditional stat estimation improves the system accuracy. In test case III of [51] IEEE 118-bus system includes a few tests. The first test has three parts, which are Centralized State Estimation (CSE) without PMU, CSE with PMU in the iteration, as well as CSE with PMU data in post processing part. The second test is the same as the first one but in distributed state estimation (DSE), it includes DSE without PMU, DSE with PMU on the sub systems and PMU in the coordinator level. The results for all the tests show the addition of PMU improves the

accuracy of the estimated value. The results obtained from the test done in [51] for the IEEE118-bus are:

Table 4.4 IEEE 118 bus test result of computation time for traditional SE and DSE

		The IEEE 118 Power system test case				
a.	Speed Comparison					
		Without PMU	With PMU pre-processing	With PMU post-processing	With PMU in local Area	PMU in Local and Coordinatore
SE	Seconds	9.985	10.2	10.6		
DSE		1.8	N/A	N/A	1.08	1.08

Table 4.4 shows the comparison for computational time between the traditional SE and the DSE on test case IEEE 118 bus system [51]. The paper includes different tests on different system sizes. In the small size systems the application of PMU is not that significant, while in the big systems it clearly shows using the DSE with the help of PMU minimizes the computational time.

Table 4.5 IEEE 118 bus test result of accuracy for traditional SE and DSE

		The IEEE 118 Power system test case		
b.	Accuracy comparison			
		Without PMU	With PMU	PMU in Local and Coordinatore
SE	Error	0.125	0.124	
DSE		2.9	N/A	1.8

Table 4.5 is the comparison of accuracy for SE and DSE [51]. As we seen in table 4.3 [50] and 4.5[51], the DSE shows a larger error than the SE, in each case the main reasons of these conditions are due to the number of measurements. Both systems are using the same number of measurements in both state estimation (DSE and SE), which means the subsystem SE will produce more errors due to the local optimum of the WLS for each sub system. The other

reason is that DSE includes more area than SE to re-estimate some additional area and to make aggregate system SE, so the error will also increase with the increase of size and system measurements. Finally the accuracy of the system could be increased with the increase in number of PMU in the system, because measurement redundancy will be increase in the system [51].

4.4 Summary

This report presents traditional state estimation techniques with and without PMUs and DSE algorithm utilizing synchronized phasor measurements. The goal was to discuss a technique that is replacing the centralized state estimation using a decentralized one to enhance the SE computation time and to get accurate data of the power system and finally to have a better system snapshot. The contribution of this research was just to discuss different techniques of SE and to determine the best possible technique. It includes the formulation of the distributed SE approach, development of an algorithm to locate PMUs, determination of the slack bus in each subsystem to coordinate the distributed SE solution, and the application of sensitivity analysis to determine the aggregation level SE measurement set to obtain an aggregated SE solution [50]. The tests were done on the IEEE 118 test case. The results obtained on the IEEE 118 bus test system demonstrate the efficacy of the proposed approach in significantly reducing the computational time and highlight the potential of the proposed approach in obtaining SE solutions for large interconnected areas. The results also show that the SE solution obtained by the proposed approach have the same accuracy as the integrated SE solution as demonstrated by the relative errors in the voltage magnitude and phase angle solutions obtained and the values of the performance index at the solution. Therefore, if the wide area network is decomposed to subsystems and if the optimal PMU placement is done properly based on the available algorithms a system snapshot could be available in almost real time and the system operators could monitor and control their system properly.

From this research project I have gained a valuable knowledge about state estimation and its importance in power system and the draw backs of the centralized state estimation due the increase in size of power system and the coming of new technologies. Most of the blackouts could have been minimized if there was enough information exchange between the system operators; the main reason for that was the lack of real time information sharing among the utilities. Deregulation made the power system a more privately concerned system. The reason

for that is the market situation. The customers got a chance to buy electricity from different utilities and this makes the utilities hide information from neighboring utilities. Even though there is development in technology such as implementation of PMU in power system the centralized type of state estimation needs to be replaced by distributed state estimation and in this section I learned a lot in how to use DSE. Distributed state estimation is used to estimate a state of a power system by sections. For example, an IEEE 118 bus system was assumed to decompose into three sub systems. The three sub systems estimate their value based on their own state estimator and the PMU is installed on the slack bus to coordinate the DSE solution from each system. From the results, when the DSE is used in the sub systems it is better than when it is used for the whole system.

Another thing I found is that, DSE can be applied to optimize the renewable energy. PMUs are intelligent electronic device which enable to provide real time data from the field into the control centers, so when DSE with the help of PMU is applied to different energy source the capability to monitor and control the systems is more effective. Say for example there is an integrated system of renewable energy, such as wind, solar as well as storage devices and the grid. If we use phasor measurement units to monitor and control the operation of the system, we have the privilege to control on a real time basis. If there is a fault in the wind farm or source we can avoid it by shedding a load or adding an additional generator to meet the available consumption. The other main point I have taken away is, the importance of smart grid. Our system is changing from time to time and currently researchers, utilities, governments and customers are more concerned about the importance of smart grid. The goal of smart grid is to make the power system operation more robust and to minimize or avoid faults from cascading. So the DSE with the help of PMU is one of the best options. The cost of phasor measurement units and other sensors and their cost of installation are very expensive, that is why ideas for implementing the PMUs phase by phase are valuable. When PMUs are installed to all the buses to monitor the wide area network, there will be no need for state estimation except for the information required to identify the bad data in the system. Therefore the application of PMU is one of the greatest applications in power system especially in state estimation and it will play a great role in smart grid operation.

Chapter 5

Recommendations and Next Steps

PMU applications for power system have been discussed earlier in this report. The capability of providing phasor measurements is the key point for its superiority. The applications are affected by many factors such as quantities and location of PMUs in the power system network and also how they incorporate with the widely used current SCADA system networks. One of the applications is SE. Some of the PMU benefits in state estimation are to provide accurate measurements of the system state. Combination of the accurate phasor measurements with other measurements reinforces the accuracy of system state estimation. It provides more precise data allowing improved topology estimation and error detection. Moreover, it can provide accurate boundary parameter data for sharing between utilities to minimize risk in each system.

The studies presented in this report showed that PMU applications offer large reliability and financial benefits for customers and utilities by providing phasor measurements and enabling supervision and control of power system operation on a real time basis. Even though it is in its early stage, many utilities have started to install PMUs in their power system network and many researches are underway to optimize its efficiency and make it cost effective. When PMUs are installed for a specific application and purpose there may be no need for a wide area monitoring system. For example, if one company wants to monitor its specific site, it needs to supervise that specific area only and it needs only a small quantity of PMUs. In the case of a power system, supervising only one utility could be possible, but power system is a huge network. So supervision and monitoring are a big issue, that is why the application of PMUs in supervising and monitoring a wide area network is more important than a single utility. Recently updated (March of 2012) [53] map of Phasor Measurement Units (PMUs) distribution within the North America power grid is shown in Fig 5.1.

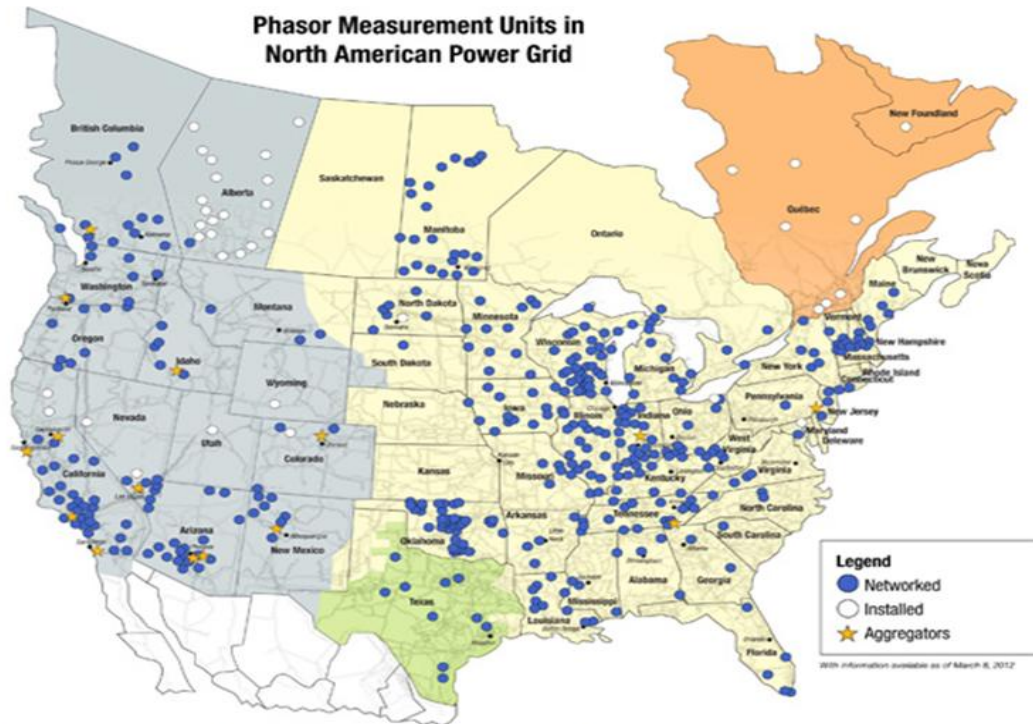

Source: North American SynchroPhasor Initiative, as of March 8, 2012.
 Note: Regional PMU data are centralized and archived at aggregators (see stars on map).

Fig.5.1 Updated map of PMU distribution in North American Power Grid [53].

Sometime ago I saw the map and the number of PMUs is increasing (e.g. Oklahoma). It indicates that, PMU installation is increasing from time to time and utilities across the North America Power System are trying to use the new technology in optimizing the power system operation. Some states and utilities have a large number, while others only have a few. The main reason for this could be, some states have high tech devices and at any cost they need to install the advanced technology, and others are environmentally friendly, so they believe that advanced technology can minimize the carbon emission by optimizing the power efficiency. Still some states may have customers with only simple loads such as lighting and some small appliances and these states are not interested in spending more money on these new technologies. But still, applying PMU in a power system network is beneficial for all the utilities and the society both from reliability and cost point of view. Initially the idea of this project was to propose PMU installation and demonstrate their results based on real data of Westar Energy power system network and Southwest Power Pool network. Unfortunately, we

didn't get time to get the data from them, but the discussion is going on and hopefully in the near future the initial goal will be achieved.

As seen in Fig 5.1 many of the states in the Midwest have installed PMUs in their systems and some of the states such as Oklahoma are increasing the quantity of their PMUs. There is a large void in States of Kansas and Nebraska. It is known that the phasor technology with its sensors is more expensive than the widely used traditional measurement devices, but I believe that due to its application in power systems it make sense to install them at critical utility buses to provide important data which is useful in monitoring the power system on a real time basis. All the utilities know that, the addition of PMU in their system can bring their system operation up to the next level, but the burden here is the expense of the technology. Implementing PMU in every bus on the system could not be possible at this time but everyone knows implementing PMUs in phases could be important and possible. That could be the reason to the increase of PMUs in the system of different utilities as seen in the map Fig 5.1.

As we said, the addition of PMU in the power network changes the system operation into the next level, which means the wide area network could be controlled based on real time. So with the increase of the power system size and the growth of renewable energy penetration into the power system, the addition of PMU is certainly important. If we take the case of Nebraska and Kansas, for example, there is new transmission line between western Kansas and Nebraska. The line will transport more than 4000MW, which is a significant amount of power [54]. So installing PMUs in the proposed transmission line will optimize the utilities system operation. In addition the proposed and existing wind project map of Kansas is shown in Fig 5.2 [53]. It implies there will be a lot of wind farm expectations. The map was taken in November 2010, I was not able to get an updated map. It is known that State of Kansas is ranked third in the nation for its wind potential and it is one of the top ten states of installed wind size [55]. Western Kansas is a place of high wind potential. When big wind farms are installed in that area, it will be a huge energy source and controlling it on a real time basis will be important. Kansas and much of Nebraska will benefit as they have populated area close to the farms. From this point of view and the future goal of multi-area monitoring and control proposals installation of PMU in these states is an important idea.

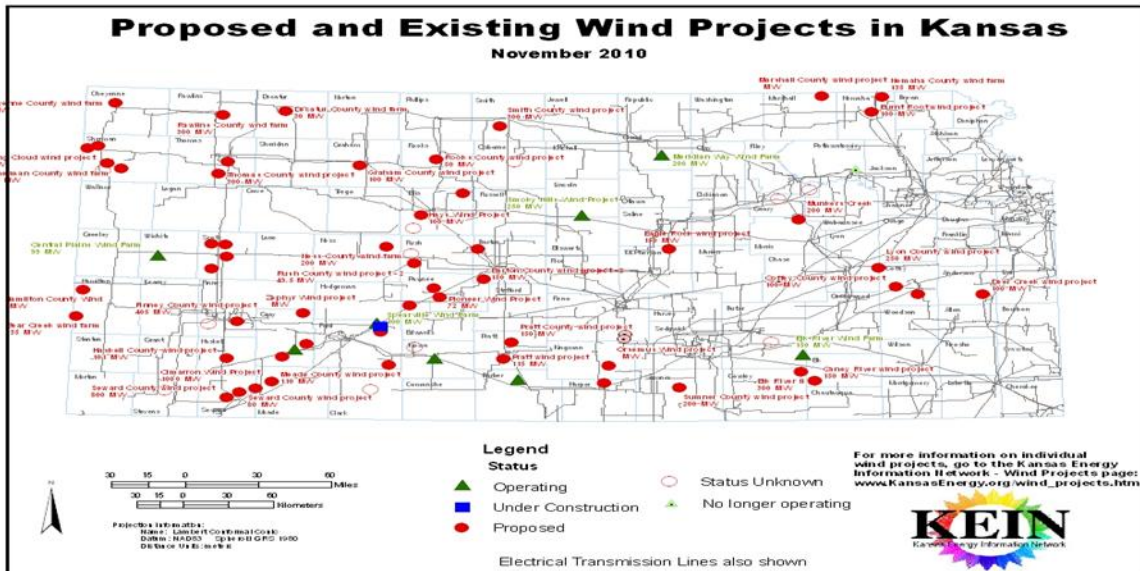

Fig.5.2 Map of Kansas proposed and existing wind project [53].

As seen from Fig. 5.2 and Table 5.1 the implementation of wind farms are increasing and in the near future there will be more electricity from the wind farm and accordingly the power system of Nebraska and Kansas will include significant wind generation. So installing PMUs in the wind farm substation can optimize the energy generation from the wind plant.

Table 5.1 Kansas Wind Farms [53]

Operating Kansas Wind Farms (Interactive Map)					
Name	County	Size (MW)	Turbine type	Turbine Model	First Year of Operation
Gray County	Gray	112	Vestas	V47	2001
Elk River	Butler	150	GE	1.5	2005
Spearville	Ford	100	GE	1.5	2006
Smoky Hills, Phase I	Lincoln/ Ellsworth	100.8	Vestas	V80	Feb. 2008
Smoky Hills, Phase II	Lincoln	150	GE	1.5sle	Dec. 2008
Meridian Way	Cloud	204	Vestas	V90	2008
Flat Ridge	Barber	100	Clipper	Liberty	2009
Central Plains	Wichita	99	Vestas	V90	2009
Greensburg	Kiowa	12.5	Suzlon		2010
Caney River	Elk	200	Vestas	V90	2011
Total		1,228			
Kansas Wind Farms Under Construction					
Post Rock	Ellsworth	201	GE	1.5	2012
Ironwood	Ford/Hodgeman	168	Siemens	2.3	2012
Flat Ridge 2	Barber/Kingman/ Sumner/Harper	419	GE	1.6	2012
Spearville 3	Ford	100.8	GE	1.6	2012
Total		889			
Kansas Wind Farms With PPA's					
Cimarron I	Gray	165	Siemens	2.3	2012
Cimarron II	Gray	131	Siemens	2.3	2012
Shooting Star	Kiowa	105	NA	NA	2012
Total		401			

How can we apply PMUs in a Wind farm or Wind generation? Even though it is not my idea, but due to its natural behavior, it is believed that wind penetration could create additional instability to the power grid. So controlling the wind farm behavior based on a real time basis and integrating it with the other sources of generation or storage devices using phasor measurement units is important. The other main point is thus, wind source, which is the healthiest electricity, is not extracted, as it should be, for many different reasons. One of the reasons is the absence of a real time basis wind farm operation, monitor, and control versus the rest of the power system; and the absence of enough storage is another point. PMU's ability to provide real time data could help in optimizing the usability of wind source by providing the capability to incorporate with other types of resources and the grid. For example, at times wind farms are generating more electricity than the grid requires, PMUs will help in directing the energy on a real time to storage devices and if wind farms stop generating electricity due to high wind speed or may be low, it could help in switching a backup generator or may stabilize the system by shedding loads without any delay.

We said that, in Kansas and Nebraska the inclusion of wind power generation is increasing from time to time. The addition of these generations will bring changes in the Kansas and Nebraska power system operation. With these changes in the generation mix and transmission grid, it is going to be essential to have up-to-date tools with updated dynamic data to monitor and control the system. These tools are mainly PMU incorporated and to avoid any risk in the network from addition of renewable energy or other faults, a synchronized system wide monitoring is important. Fig 5.3 highlights the benefit of having PMUs over the traditional SCADA system. If there is a disturbance, as it shown in Fig 5.3, a control center with only SCADA could see a fairly small disturbance as shown by the line, while with PMU data, the dynamic oscillations of the system provide a better indication of the system state [53]. Monitoring the wind farm network and wind behavior on a real time basis and supervising, monitoring, and integrating the whole system of each state and in the mid-west will be possible, if enough PMUs are installed in the system, but the addition of the initial PMUs will help to monitor and control each specific task in the assigned systems.

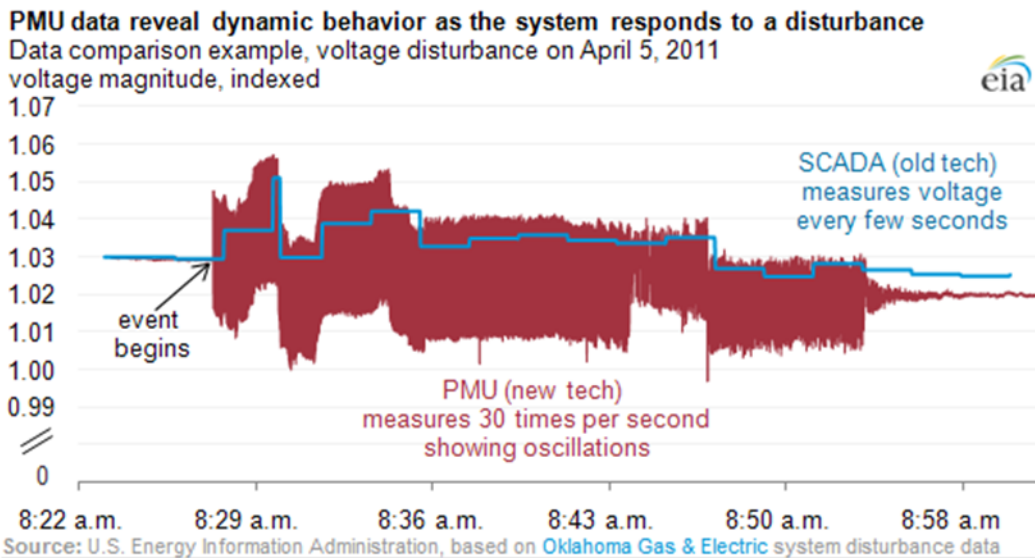

Fig.5.3 Data Comparison between PMU and SCADA for Oklahoma Gas & Electric system distribution data [53].

As we have seen the distributed state estimation (DSE) in the report describes an effective approach to alleviate the computational burden by distributing the SE computation across the system rather than centralize it at the control centers. To utilize decentralization and form subsystems of large power systems, decomposition and aggregation are done to minimize measurement errors, bad conditioning and to provide ultra wide monitoring with the help of PMUs. As I said previously, PMUs are providing phasor measurements, which help to aggregate the voltage and phase angle of each decomposed subsystem of the large system. In Table 4.6 the result of the integrated system state estimation and the SE of the boundary bus state variables and sensitive internal bus state variables are provided. It shows clearly the benefit of distributed state estimation. As explained in [51], DSE technique works by estimating the local states and combining the results from the local state estimators to one coordinating center. This type of state estimation is interesting because, currently the utilities are reluctant to share information with their competitors for obvious reasons, but they will not be afraid to give information to the coordinating estimator such as ISO/RTO as the ISO/RTO are nonprofit organization. The other advantage of this technique is that, it does not require the modification of the existing state estimation technique, which produces no extra cost. So far we have seen the use of DSE and Phasor measurements in providing ultra wide area

monitoring and its advantages over the traditional method of SE. Therefore, for monitoring the integration of wind generation and grid in Kansas and Nebraska power system, the technique proposed by [51] could be the best solution. It will provide different options of state estimation for different parts of the power system. If the optimization of wind farm alone is required, it is possible and it can provide the possible coordination between wind generation, storage as well as the power grid by providing synchronized time stamped data to system operator.

In addition the installation of PMUs in the transmission grid of Kansas and Nebraska would help to synchronize the power system across the Southwest Power Pool (SPP). If all states install PMUs and implement the technique of distributed state estimation discussed in this report they will minimize the computational time of their SE operations, get an ultra-wide area monitoring, and double the current capacity of wind generation in State of Kansas by installing enough PMUs in all wind farms. PMUs could eventually replace the SCADA systems in making the power grid reliable and effective by providing system observation capabilities and improving reliability for customers. Finally if the real data from Westar Energy or from SPP is obtained, the advantage of the proposed technique DSE with the help PMUs over the widely used SCADA system could be demonstrated.

References

- [1]. H.M. Merrill, "Regional transmission organizations: FERC Order 2000" IEEE Power Engineering Review, Vol. 20 Issue: 7, July 2000 pp. 3 –5.
- [2]. Federal Energy Regulatory Commission "RTO Regional Map" October 2011 Available: <http://www.ferc.gov/industries/electric/indus-act/rto.asp>
- [3]. Bobbie J., McCartney, "Proposed Mediation Model for a Southeastern Regional Transmission Organization" Submitted by the SeTrans sponsors, August 2001.
- [4]. U.S.-Canada Power System Outage Task Force "Final Report on the August 14, 2003 Blackout in the United States and Canada: Causes and Recommendations" April 2004 [online] Available: <https://reports.energy.gov/>. (Accessed 10/20/2011).
- [5]. A. J. Wood and B. F. Wollenberg, "*Power Generation, Operation, and Control*", New York: John Wiley & Sons, 1996
- [6]. A.G. Phadke and J. S. Thorp, *Synchronized Phasor Measurements and Their Application*, Springer Science + Business Media, 2008.
- [7]. A. Abur and A. G. Exposito, *Power System State Estimation- Theory and Implementation*: CRC, 2004.
- [8]. F. C. Schweppe and J. Wildes, "Power System Static-State Estimation, Part I: Exact Model," IEEE Transactions on Power Apparatus and Systems, vol. PAS-89, pp. 120-125, 1970.
- [9]. F. C. Schweppe and D. B. Rom, "Power System Static-State Estimation, Part II: Approximate Model," IEEE Transactions on Power Apparatus and Systems, vol. PAS-89, pp. 125-130, 1970.
- [10]. F. C. Schweppe, "Power System Static-State Estimation, Part III: Implementation," IEEE Transactions on Power Apparatus and Systems, vol. PAS-89, pp. 130-135, 1970.
- [11]. A. G. Phadke "Synchronized Phasor Measurements – A Historical Overview," Transmission and Distribution Conference and Exhibition 2002: Asia Pacific. IEEE/PES, vol. 1, pp. 476-479, 2002.
- [12]. A. G. Phadke, "Synchronized Phasor measurements in power systems," IEEE Computer Applications in Power, Vol.6, Issue 2, pp. 10-15, April 1993.)
- [13]. A. Monticelli, *State Estimation in Electric Power Systems: A Generalized Approach*, Kluwer Academic Publishers, 1999.

- [14]. J. D. Glover, M. S. Sarma, and T. J. Overbye, Power System Analysis and Design: Thomson, 2008.
- [15]. K. E. Martin. "IEEE Standard for Synchrophasors for Power Systems" IEEE Transactions on Power Delivery, Vol. 13, No. 1, January 1998.
- [16]. D.Jun, C.Ze-xiang and W. Keying, "An overview of state estimation based on wide area –measurement system," Automation of Electric Power Systems, Vol. 30, No. 7, pp.5-9, 2006.
- [17]. M.Zhou, V.A.Centeno,J.S.Thorp, and A.G.Phadeke, "An Alternative for including phasor measurements in state estimators," Power Systems, IEEE Transactions on , Vol. 21, pp. 1930-1937, 2006
- [18]. L.Zhou and A. Abur, "Multiarea state estimation using synchronized phasor measurements" IEEE Transactions on Power Systems , Vol. 20, No. 2,pp. 611-617, May 2005.
- [19]. T. L. Baldwin, L. Mili, M. B. Boisen, Jr., and R. A. Adapa, "Power System Observability with Minimal Phasor Measurement Placement," IEEE Transactions on Power Systems, vol. 8, pp. 707-715, 1993.
- [20]. R. F. Nuqui and A. G. Phadke, "Phasor Measurement Unit Placement Techniques for Complete and Incomplete Observability," IEEE Transactions on Power Delivery, vol. 20, pp. 2381-2388, 2005.
- [21]. Synchrophasor Based Tracking Three Phase State Estimator and It's Applications, A.G. Phadke Virginia Tech, Blacksburg, VA. DOE 2010 Transmission Reliability Program Peer Review, October 19-20, 2010 at the Westin Alexandria.
- [22]. N. I. Voropai, "Investments and development of electric power industry in market environment", Proc. Int. Power System Technology Conf., Kunming, China, October 2002.
- [23]. W. J. Lee, and C. H. Lin, "Utility deregulation and its impact on the industrial power systems", IEEE Industrial and Commercial Power Systems Technical Conf. Record, Philadelphia, PA, May 1997.
- [24]. G. J. Miranda, "Be Prepared! [power industry deregulation]", IEEE Industry Applications Magazine, vol. 9, no. 2, March/April 2003.

- [25]. G. M. Huang, and J. Lei, "Measurement design of data exchange for distributed multi-utility operation", IEEE Power Engineering Society Winter Meeting, New York, NY, January 2002.
- [26]. E. Iwata, "Report faults Ohio utility", USA Today, pp. 1A , November 20, 2003.
- [27]. K. A. Clements, O. J. Denison, and R. J. Ringlee, "A multi-area approach to state estimation in power system networks," Proc. IEEE Power Eng. Society Summer Meeting, San Francisco, CA, 1972, C72 465-3.
- [28]. S. Iwamoto, M. Kusano, and V. H. Quintana, "Hierarchical state estimation using a fast rectangular-coordinate method," IEEE Trans. Power Syst., vol. 4, no. 3, pp. 870–879, Aug. 1989.
- [29]. Zhao, Liang. "Multi-area Network Analysis" Dissertation submitted to Texas A&M University, pp.6-34, Dec. 2004.
- [30]. C. W. Brice and R. K. Cavin, "Multiprocessor static state estimation," IEEE Trans. Power Appar. Syst., vol. 101, no. 2, pp. 302–308, Feb.1983.
- [31]. M. S. Kurzyn, "Real-time state estimation for large-scale power systems," IEEE Trans. Power Appar. Syst., vol. 102, no. 7, pp.2055–2063, Jul. 1983.
- [32]. T. Van Cutsem, J. L. Horward, and M. Ribbens-Pavella, "A two-level static state estimator for electric power systems," IEEE Trans. Power Appar. Syst., vol. PAS-100, no. 8, pp. 3722–3732, Aug. 1981.
- [33]. A. A. El-Keib, J. Nieplocha, H. Singh, and D. J. Maratukulam, "A decomposed state estimation technique suitable for parallel processor implementation," IEEE Trans. Power Syst., vol. 7, no. 3, pp. 1088–1097, Aug. 1992.
- [34]. R. Ebrahimian and R. Baldick, "State estimation distributed processing," IEEE Trans. Power Syst., vol. 15, no. 4, pp. 1240–1246, Nov. 2000.
- [35]. S. Y. Lin, "A distributed state estimator for electric power systems," IEEE Trans. Power Syst., vol. 7, no. 2, pp. 551–557, May 1992.
- [36]. D. M. Falcao, F. Wu, and L. Murphy, "Parallel and distributed state estimation," IEEE Trans. Power Syst., vol. 10, no. 2, pp. 724–730, May 1995.
- [37]. T. Van Cutsem and M. Ribbens-Pavella, "Critical survey of hierarchical static state estimation in large scale power systems," IEEE Trans. Power Appar. Syst., vol. PAS-102, no. 10, pp. 247–256, Oct. 1983.

- [38]. A. R. Khatib, R. F. Nuqui, M. R. Ingram, and A. G. Phadke, "Realtime estimation of security from voltage collapse using synchronized phasor measurement, PESGM2004-000486," Proc. IEEE PES General Meeting, Denver, CO, Jun. 2004.
- [39]. W. Jiang and V. Vittal, "Optimal placement of phasor measurements for the enhancement of state estimation," Proc. Power Systems Conference and Exposition, Atlanta, GA, Oct. 2006,
- [40]. A. G. Phadke, "Synchronized phasor measurements in power systems," IEEE Comput. Applicat. Power, vol. 6, no. 2, pp. 10–15, Apr. 1993.
- [41]. A. R. Khatib, R. F. Nuqui, M. R. Ingram, and A. G. Phadke, "Realtime estimation of security from voltage collapse using synchronized phasor measurement, PESGM2004-000486," Proc. IEEE PES General Meeting, Denver, CO, Jun. 2004.
- [42]. W. Jiang and V. Vittal, "Optimal placement of phasor measurements for the enhancement of state estimation," Proc. Power Systems Conference and Exposition, Atlanta, GA, Oct. 2006, #1106.
- [43]. E. Handschin and C. Bogers, "Theoretical and practical considerations in the design of state estimators for electric power systems," Proc. Int. Symp. COPOC'75, Sao Carlos, Brazil, Aug. 1975, pp. 104–136.
- [44]. H.-J. Koglin, D. Oeding, and K. D. Schmitt, "Local redundancy and identification of bad measuring data," Proc. 9th Power Systems Conf., Cascais, Portugal, 1987, pp. 528–534.
- [45]. A. Al-Atwan and H.-J. Koglin, "Two aspects of local redundancy in state estimation," Proc. Inst. Elect. Eng., vol. 145, no. 4, pp. 458–462, Jul. 1998.
- [46]. M. B. Do Coutto Filho, J. C. S. de Souza, F. M. F. de Oliveira, and M. T. Schilling, "Identifying critical measurements and sets for power system state estimation," in Proc. Power Tech 2001, Porto, Sep. 2001, vol. 3, pp. 6–12.
- [47]. N. G. Bretas and J. B. A. London Jr., "Measurement placement design and reinforcement for state estimation purposes," Proc. Power Tech., Porto, Sep. 2001, vol. 3, pp. 6–12.
- [48]. Power System Test Cases Archive, [Online]. Available: <http://www.ee.washington.edu/research/pstca/> (Accessed 07/15/2011)
- [49]. Power Flow Program 5.0. Surrey, BC, Canada, Powertech Labs, Inc.

- [50]. Weiqing Jiang, Vijay Vittal, and Gerald T. Heydt, “A Distributed State Estimator Utilizing Synchronized Phasor Measurements” IEEE Trans. On Power Systems, VOL. 22, No. 2, May 2007
- [51]. Qinghua Huang, Noel N. Schulz, Anurag K.Srivastava, and Tomasz Haupt, “Distributed State Estimation with PMU Using Grid Computing” PHD dissertation Mississippi State University, December 2010
- [52]. Ranjana sodhi “Synchrophasor assisted state estimation and voltage stability monitoring including optimal PMU placement.”, Department of electrical Engineering , Indian Institute of technology Kanpur,India. November, 2010 PHD dissertation .
- [53]. Phasor Measurement Units (PMU) in North American Power Grid. [online] <http://www.eia.gov/todayinenergy/detail.cfm?id=5630#> (Accessed 4/27/2012).
- [54]. “Proposed and Existing wind projects in State of Kansas “on line” http://www.kansasenergy.org/wind_projects.htm (Accessed 5/1/2012).
- [55]. Kansas wind industry “on line” <http://www.kansaswindindustry.com/> (Accessed 5/1/2012).